

Explosion Proof  
Motors

[hoyermotors.com](http://hoyermotors.com)



Explosion Proof

**HOYER**  
MOTORS



# HOYER

EXCEEDING EXPECTATIONS

Svend Hoyer A/S is an international company comprising the two business units Hoyer Motors and Hoyer Transmissions. Headquartered in Denmark and China, we are represented through subsidiaries and sales offices in a number of countries across the globe. We pride ourselves of being an elite manufacturing enterprise with the highest attention to service and support – a company where dedication, competitiveness and reliability are second to none.

At Svend Hoyer A/S, meeting agreements is as natural as breathing air. Our motto: A promise is a promise, is the foundation for always supplying solutions that meet – or, indeed, exceed our customers' expectations in every respect. Our business policy is always to be direct in our approach, even in the rare case of complaint or criticism.

In other words, Svend Hoyer A/S is a company you can rely on. A trustworthy business partner that always meets our obligations on deliveries and technical solutions – both in the short and long term. This is what we mean by Exceeding Expectations.

## Introduction

Hoyer explosion proof motors are distinguished by high material quality, robust design, high index of IP protection, bearings greased for life, weather and corrosion resistant final overcoat and high dielectric strength insulation system intended to be feed by static frequency converter.

Local conditions must be divided in danger zones, defined by end user together with appropriate establishment, ac-

ording to frequency and duration of appearance of an explosive gas atmosphere.

An overview of all Hoyer products for areas of application categories, types of protection and adequate indexes of mechanical protection is given below.

	Group	Device category	Appearance frequency of ex. atmosphere	Zone	Type of protection	Temp. class	Index of mech. protection	Motor type
Gases and vapour (G)	I	M2	Surface		Ex d I	-	IP55	7AT 132 - 315
	II	IEC Ex SCHEME	Frequently	1	Ex d IIC Gb	T3, T4	IP55 IP6x, IPx6	5AT 71 - 112
		2G			Ex de IIC Gb	T3, T4, T5, T6		5AT 71 - 112
		3G	Rarely and short time	2	Ex e IIC Gb	T3		7AT 132 - 315
					Ex nA IIC Gc			5AZS 63 - 112
							HMA 63 - 160*	
						HMC 132 - 315*		
Dust (D)	II	2D	Frequently	21	Ex tb IIIC Db Conductive dust	Max. housing temp. T 120°C	IP6x	5AT 71 - 112
								5AZS 63 - 112
	II	3D	Rarely and short time	22	Ex tc IIIB Dc Non conductive dust		IP5x, IP65	HMA2 63 - 132*
								HMC2 160 - 400*

\* Data as Hoyer Standard Motors

## AT series enclosure „d“

### Motors of AT series in protection enclosure „d“

Three-phase induction TEFC motors, and designed in protection enclosure „d“ may be used in zones 1 and 2 endangered by explosive atmosphere, area of use II (all industry except mining). In these zones such an atmosphere can occur during normal operation (zone 1), or its appearing is not expected and if it does occur, it lasts for short time period (zone 2). Explosive atmosphere is a mixture of some flammable substances and air in the form of gas, vapour, mist or dust. Named dangerous zones exists in e.g.: gas plants, paint shops, chemical and pharmaceutical industry, refineries, tankers etc.

Designed according to IEC 60079-0, IEC 60079-1, IEC 60079-70 and IEC 60079-31. Motors of series 5AT and 7AT are certified in conformity with last edition of IEC, European standards and CESI (Italy) for EU and IEC Ex Scheme.

All our flameproof motors series 5AT and 7AT have the highest explosion group IIC, temperature classes T1 to T4 at ambient temperatures from -20 to +60 °C. Declaration of conformity for the motors and Operating Instructions are supplied as standard with explosion-proof motors in English.

#### Standard design

Series	5AT 71 – 112 aluminum alloy die casted ribbed housing with die casted feet, cast iron terminal box and bearing shields 7AT 132 – 315 cast iron ribbed housing, demountable feet, cast iron terminal box and bearing shields
EX protection	Ex II 2G Ex de IIC T4 Gb (housing in enclosure „d“, terminal box in „e“)
Mounting designs	B3, B5, B35, B14, B34 (last two up to frame size 112)
Terminal box	Terminal box situated on top, viewed from motor drive end side on the motor with feet
Power range	Series 5AT 71 – 112 with power range 0,09 – 4,0 kW: 7AT 132 – 315 with power range 2,2 – 200 kW
Duty	S1 (for ambient -20°C to +50°C and up to 1000 ASL)
Voltage and frequency	230/400V ± 10% Δ/Y (up to 2,2 kW), 400/690V ± 10% Δ/Y (3 kW and above) and 50Hz
Efficiency	in class IE1 according to IEC 60034-30 (IE2 on request)
Number of poles	single speed motors: 2, 4, 6 and 8
Protection index	IP 55
Insulation class	F (temperature rise in B, wire in H)
Colour tone	RAL 9005 Black

## Supply by frequency converter

Motors of 5AT and 7AT series are designed and tested in accordance with IEC 60034-1 and can be driven (supplied) by frequency converter, in terms compatible with IEC 60034-17, within regulation range between 5 to 87 Hz for motor polarity 2p=2, and for other polarities in range of regulation between 5 to 100 Hz. Motors for frequency converter drive have a built-in thermal protection in winding. Frequency converter is situated outside hazardous area. Motor characteristics in operation at various frequencies are defined on the additional rated name plate.

The type of protection, ambient temperature and mechanical protection of the explosion-proof motor with separately driven fan corresponds to that of the associated explosion-proof basic motor. Motors with a separately driven fan must be equipped with a PTC thermistor as motor protection. In the event of a fault in the separately driven fan, the PTC thermistor must reliably trip the motor. A rating plate listing all the important data is fitted to the separately driven fan. When a separately driven fan is mounted, the length of the motor increases.

## Options

Explosion protection options		
Explosion protection	Description	Series
Ex II 2G Exd(e) IIC T4/T3 Gb	Motor housing and terminal box in "d", without cable glands but with certified plugs	5AT, 7AT
Ex II 2G Exd IIC T4/T3 Gd	Motor housing in „d“ without terminal box, with DIRECT CABLE ENTRY length 1,5m	5AT, 7AT
Ex II 2D tb III C T135 °C Db IP66	Motor housing in "d", terminal box in "d" or "e", for DUST	5AT
Ex II 2G Exd(e) IIB T3 Gb	Motor housings in „d“, terminal box in „d“ or „e“, for GASES and ambient temperature -20°C to +80°C	5AT, 7AT
II 2G Exd(e) IIC T4/T3 Gb	Motor housings in „d“, terminal box in „d“ or „e“, for GASES, IEC Ex SCHEME	5AT
Ex I M2 Ex d(e) I Mb	Motor housings in „d“, terminal box in „d“ or „e“, for mines	7AT

Other voltages (or multi-voltage) and frequencies
Electrical acc. to „NEMA Standards Publication No MG1“
Different pole numbers for single and multi-speed motors
Other mounting arrangements
Thermal protection (PTC thermistors or thermal switches or PT100)
Free shaft end on both motor side
Special flanges and free shaft ends
Flange mounting motors with flange and shaft extension acc. to NEMA
Terminal box on left or right motor side
Other colour tones and/or surface paints and/or special chemical resistant surface paints
Fan cover with protection from rainfall and textile fibre
Cooling types (IC410, IC416, IC418)
Winding for tropical environment
Winding heaters
Marine design (ABT)
Protection indexes: IP56, IP65, IP66
Roller bearings
SPM nipple in bearing shields – 7AT
Stainless steel bolts
Armoured version and/or welded construction for heavy duty in mines (I M2)
For duty types S2 to S10
Driven by frequency converter
Other temperature classes: T5-T6
For other ambient temperatures (-20°C to +50°C; -20°C to +60°C; -20°C to +80°C)
Frequency inverter driven: 2 pole within regulation range 5 – 87 Hz, other on request
And other customer demand based design
Built-in options:
Ex d(e) II protected brake
Ex d(e) II protected forced ventilation (cooling type IC 416) (7AT series)
Ex d(e) encoder
Connecting cable



# IE1 / 2 pol

P (kW)	Motor type	3000 min <sup>-1</sup>			400V/50Hz							440V/60Hz/3600 min <sup>-1</sup>		
		n (min <sup>-1</sup> )	η (%)	cos φ	I <sub>n</sub> (A)	$\frac{I_k}{I_n}$	$\frac{M_n}{(N_{in})}$	$\frac{M_k}{M_n}$	$\frac{M_{max}}{M_n}$	J (kgm <sup>2</sup> )	m (kg)	P (kW)	n (min <sup>-1</sup> )	I <sub>n</sub> (A)
0,37	5AT 71A-2	2750	70	0,80	0,95	3,8	1,25	2,0	2,1	0,0002675	10	0,4	3300	0,95
0,55	5AT 71B-2	2760	70	0,82	1,4	4,2	1,9	2,2	2,2	0,0003864	11,2	0,6	3260	1,4
0,75	5AT 80A-2	2830	73	0,80	1,85	4,5	2,55	2,6	2,6	0,0006421	14	0,8	3400	1,85
1,1	5AT 80B-2	2830	79	0,83	2,45	4,9	3,75	2,6	2,6	0,0007932	16,2	1,2	3400	2,45
1,5	5AT 90S-2	2820	78	0,82	3,4	5,3	5	2,6	2,6	0,0013963	18,9	1,7	3385	3,4
2,2	5AT 90L-2	2820	80,5	0,79	5	5,6	7,5	2,8	2,9	0,0018297	21,8	2,5	3385	5
3	5AT 100L-2	2870	83	0,84	6,2	6,6	10	3,2	3,4	0,0058900	26,7	3,4	3420	6,2
4	5AT 112M-2	2900	85	0,85	8,0	7,0	13	3,2	3,4	0,0055715	37,7	4,5	3480	8
5,5	7AT 132SA-2	2900	85	0,83	11,3	7,0	18	2,6	3,4	0,0098428	78	6,2	3480	11,3
7,5	7AT 132SB-2	2900	87	0,87	14,3	7,0	25	2,6	3,2	0,0131237	92	8,5	3480	14,3
9,5	7AT 132M-2	2920	88	0,87	18	7,5	30	3,0	3,6	0,1757640	89	11	3500	18
11	7AT 160MA-2	2920	89	0,85	21	7,3	35	3,0	3,3	0,0322889	144	12,5	3510	21
15	7AT 160MB-2	2930	90	0,89	27	8,8	50	3,0	3,8	0,0448163	154	17	3520	27
18,5	7AT 160L-2	2940	90	0,90	33	8,8	60	3,0	3,8	0,0534620	168	21	3530	33
22	7AT 180M-2	2940	90	0,85	41,5	7,5	70	3,0	3,8	0,0717981	215	25	3530	41,5
30	7AT 200LA-2	2950	92	0,89	53	7,5	95	2,2	2,4	0,1240044	240	33	3540	52
37	7AT 200LB-2	2955	92,5	0,89	65	7,5	120	2,3	2,5	0,1521450	257	42	3550	65
45	7AT 225M-2	2950	93	0,90	77,5	7,5	145	2,3	2,5	0,2313039	364	50	3540	77,5
55	7AT 250M-2	2960	94	0,88	96	7,3	175	2,2	2,8	0,3784069	470	62	3550	96
75	7AT 280S-2	2970	94	0,89	129,5	7,5	240	2,2	2,8	0,6103675	635	85	3550	130
90	7AT 280M-2	2970	94	0,89	155,5	7,5	290	2,2	2,8	0,7325516	680	105	3550	156
110	7AT 315S-2	2975	94,5	0,90	186	7,0	355	2,0	2,5	1,4435297	840	124	3570	187
132	7AT 315M-2	2980	95	0,90	222	7,7	425	2,2	2,7	1,7320736	885	149	3575	223
160	7AT 315LA-2	2980	95	0,90	268	7,5	515	2,3	2,5	2,0992375	935	180	3575	269
200	7AT 315LB-2	2985	95,5	0,91	330	8	640	2,1	2,5	2,6236417	1050	225	3580	330

## IE1 / 4 pol

P (kW)	Motor type	1500 min <sup>-1</sup>			400V/50Hz							440V/60Hz/1800 min <sup>-1</sup>		
		n (min <sup>-1</sup> )	η (%)	cos φ	I <sub>n</sub> (A)	$\frac{I_k}{I_n}$	$\frac{M_n}{(N_m)}$	$\frac{M_k}{M_n}$	$\frac{M_{max}}{M_n}$	J (kgm <sup>2</sup> )	m (kg)	P (kW)	n (min <sup>-1</sup> )	I <sub>n</sub> (A)
0,25	5AT 71A-4	1370	61	0,72	0,85	3,4	1,7	2,0	2,1	0,0004533	10	0,3	1640	0,85
0,37	5AT 71B-4	1360	66	0,75	1,1	3,4	2,6	2,0	2,1	0,0006421	10,7	0,4	1630	1,1
0,55	5AT 80A-4	1390	70	0,76	1,6	4,1	3,8	2,0	2,1	0,0010111	13,8	0,6	1670	1,6
0,75	5AT 80B-4	1390	75	0,76	1,9	4,1	5,2	2,2	2,3	0,0013000	14,4	0,8	1670	1,9
1,1	5AT 90S-4	1380	75,5	0,78	2,7	4,1	7,5	2,2	2,3	0,0023660	18,1	1,2	1660	2,7
1,5	5AT 90L-4	1380	78	0,80	3,5	4,4	10,5	2,2	2,3	0,0236600	21	1,7	1660	3,5
2,2	5AT 100LA-4	1410	81	0,80	4,9	5,0	15	2,2	2,3	0,0031550	26,7	2,5	1690	4,9
3	5AT 100LB-4	1410	82,5	0,81	6,5	5,5	20	2,5	2,8	0,0070838	28,8	3,4	1690	6,5
4	5AT 112M-4	1435	84,5	0,80	8,5	6,5	27	2,8	3,0	0,0121970	39,8	4,5	1720	8,5
5,5	7AT 132S-4	1435	85,5	0,85	11	5,9	37	2,5	3,0	0,0201923	87	6,2	1720	11
7,5	7AT 132M-4	1440	87	0,83	15	6,5	50	2,7	3,2	0,0276316	89	8,5	1730	15
9,5	7AT 132MA-4	1440	88	0,82	19	6,7	65	2,9	3,3	0,0349191	93	11	1730	19
11	7AT 160M-4	1460	88,6	0,82	22	7,3	75	2,8	3,3	0,0612475	154	12,5	1750	22
15	7AT 160L-4	1460	89,7	0,83	29	7,0	100	2,7	3,1	0,0822467	170	17	1750	29
18,5	7AT 180M-4	1460	90,5	0,83	35,5	7,5	120	2,7	3,1	0,1261614	205	21	1750	35,5
22	7AT 180L-4	1460	91	0,84	41,5	7,5	145	2,8	3,1	0,1514499	224	25	1750	41,5
30	7AT 200L-4	1470	93,5	0,85	54,5	7,5	195	2,4	2,6	0,2431014	300	34	1760	55
37	7AT 225S-4	1475	93,5	0,85	67	7,1	240	2,3	2,6	0,3823324	359	42	1780	67
45	7AT 225M-4	1470	94,3	0,85	81	7,2	290	2,4	2,6	0,4622828	391	52	1780	81
55	7AT 250M-4	1480	94,2	0,86	98	7,5	355	2,4	2,8	0,7180200	500	63	1780	98
75	7AT 280S-4	1480	93,5	0,83	140	7,5	485	2,4	2,8	1,1863770	655	85	1780	145
90	7AT 280M-4	1480	94,5	0,83	165	7,5	580	2,4	2,8	1,4242154	700	103	1780	165
110	7AT 315S-4	1485	95	0,88	190	7,4	705	2,0	2,6	2,5126648	920	124	1785	190
132	7AT 315M-4	1485	95	0,88	228	7,5	850	2,1	2,8	3,0983389	985	149	1785	228
160	7AT 315LA-4	1485	95,5	0,88	275	7,5	1030	2,1	2,8	3,9358939	1020	180	1785	275
200	7AT 315LB-4	1490	95	0,82	370	7	1280	1,7	2,2	4,6065522	1350	225	1785	370

# IE1 / 6 pol

P (kW)	Motor type	1000 min <sup>-1</sup>			400V/50Hz							440V/60Hz/1200 min <sup>-1</sup>		
		n (min <sup>-1</sup> )	η (%)	cos φ	I <sub>n</sub> (A)	$\frac{I_k}{I_n}$	$\frac{M_n}{(N_{in})}$	$\frac{M_k}{M_n}$	$\frac{M_{max}}{M_n}$	J (kgm <sup>2</sup> )	m (kg)	P (kW)	n (min <sup>-1</sup> )	I <sub>n</sub> (A)
0,18	5AT 71A-6	870	51	0,67	0,9	2,2	2	1,6	1,8	0,0004533	9,9	0,2	1040	0,9
0,25	5AT 71B-6	880	53	0,65	1,1	2,5	2,7	1,7	1,8	0,0006421	10,6	0,3	1060	1,1
0,37	5AT 80A-6	900	65	0,75	1,2	3,5	4	1,7	2,0	0,0017609	13,5	0,4	1080	1,2
0,55	5AT 80B-6	900	67	0,77	1,7	3,4	5,75	2,1	2,2	0,0022011	14,1	0,6	1080	1,7
0,75	5AT 90S-6	900	70	0,65	2,4	3,2	8	2,2	2,3	0,0023898	17,6	0,8	1080	2,4
1,1	5AT 90L-6	900	73	0,68	3,2	3,2	12	2,0	2,1	0,0031444	20,6	1,2	1080	3,2
1,5	5AT 100L-6	910	76	0,80	3,6	4,0	15	1,9	2,1	0,0104248	26,7	1,7	1090	3,6
2,2	5AT 112M-6	930	78	0,72	5,7	5,3	25	2,7	3,1	0,0148147	36,7	2,5	1110	5,7
3	7AT 132S-6	940	81,5	0,72	7,4	4,6	30	2,1	2,5	0,0276896	87	3,4	1130	7,4
4	7AT 132MA-6	950	83,1	0,70	9,7	5,5	40	2,7	3,0	0,0452618	87	4,5	1140	9,7
5,5	7AT 132MB-6	950	84	0,74	12,8	5,8	55	2,8	3,0	0,0452618	89	6,2	1140	12,8
7,5	7AT 160M-6	965	86,5	0,81	15,5	7,0	75	2,8	3,2	0,0924623	151	8,2	1160	15,5
11	7AT 160L-6	965	88	0,82	22	7,0	110	2,8	3,2	0,1261090	173	12,5	1160	22
15	7AT 180L-6	970	90,5	0,84	28,5	7,8	150	2,7	3,6	0,1909081	195	17	1160	28,5
18,5	7AT 200LA-6	970	90	0,80	37	6,5	180	2,2	2,5	0,2385562	252	21	1170	37
22	7AT 200LB-6	975	91	0,82	42,5	6,1	215	2,2	2,8	0,3192255	281	25	1170	42,5
30	7AT 225M-6	975	92,5	0,83	56,5	7,3	295	3,0	3,0	0,7261691	392	34	1170	56,8
37	7AT 250M-6	985	93	0,75	78,5	7,8	360	2,8	3,0	1,0001489	426	42	1180	78,5
45	7AT 280S-6	985	93	0,77	90	7,8	435	2,5	3,0	1,4678774	555	50	1180	90
55	7AT 280M-6	985	93,5	0,77	110	7,8	535	2,5	3,0	1,7612895	595	60	1180	110
75	7AT 315S-6	990	94	0,82	140	7,3	725	2,5	2,6	4,4698275	840	84	1185	140
90	7AT 315M-6	990	94,5	0,80	172	7,5	870	2,1	2,7	5,5523680	905	101	1185	172
110	7AT 315LA-6	990	95	0,80	208	7,6	1060	2,1	2,7	6,7528900	1000	124	1185	208



P (kW)	Motor type	750 min <sup>-1</sup>			400V/50Hz							440V/60Hz/900 min <sup>-1</sup>		
		n (min <sup>-1</sup> )	η (%)	cos φ	I <sub>n</sub> (A)	$\frac{I_k}{I_n}$	$\frac{M_n}{(N_{in})}$	$\frac{M_k}{M_n}$	$\frac{M_{max}}{M_n}$	J (kgm <sup>2</sup> )	m (kg)	P (kW)	n (min <sup>-1</sup> )	I <sub>n</sub> (A)
0,09	5AT 71A-8	660	43	0,53	0,60	2,0	1,3	1,8	1,9	0,0004533	9,9	0,09	790	0,60
0,12	5AT 71B-8	660	43	0,54	0,75	2,0	1,7	2,0	2,2	0,0006421	10,6	0,12	790	0,75
0,18	5AT 80A-8	700	60	0,58	0,75	3,0	2,5	2,3	2,6	0,0017609	13,4	0,2	840	0,75
0,25	5AT 80B-8	680	60	0,61	1,05	2,6	3,5	1,7	2,0	0,0017609	14	0,3	820	1,05
0,37	5AT 90S-8	690	58	0,57	1,7	2,5	5	1,7	2,0	0,0023898	17,6	0,4	830	1,7
0,55	5AT 90L-8	670	60	0,58	2,2	2,8	7,5	2,0	2,1	0,0031440	20,6	0,6	810	2,2
0,75	5AT 100LA-8	700	65	0,60	2,8	3,1	10	1,8	2,2	0,0078186	26,4	0,8	840	2,8
1,1	5AT 100LB-8	700	73	0,62	3,5	3,7	15	2,1	2,4	0,0104248	29,8	1,2	840	3,5
1,5	5AT 112M-8	680	72	0,70	4,3	3,8	20	1,9	2,3	0,0148147	38	1,7	820	4,3
2,2	7AT 132S-8	690	78	0,78	5,2	4,2	30	2,0	2,1	0,0261601	83	2,5	830	5,2
3	7AT 132M-8	690	78	0,76	7,4	4,2	40	2,1	2,4	0,0364714	82	3,4	830	7,4
4	7AT 160MA-8	710	85	0,73	9,7	4,8	55	2,0	2,7	0,0790497	134	4,5	850	9,7
5,5	7AT 160MB-8	710	85	0,75	13	5,1	75	2,0	2,7	0,1043681	154	6,2	850	13
7,5	7AT 160L-8	720	86	0,78	16,5	5,5	100	2,2	2,6	0,1423456	169	8,5	860	16,5
11	7AT 180L-8	720	88	0,80	24	5,6	145	2,3	2,8	0,2370801	225	12,5	860	24
15	7AT 200L-8	730	90	0,78	31	5,8	200	1,9	2,4	0,4288579	255	17	880	31
18,5	7AT 225S-8	735	91	0,78	38	5,9	240	2,0	2,6	0,6039500	327	21	880	38
22	7AT 225M-8	735	91	0,78	45	5,9	285	2,0	2,5	0,7296794	349	25	880	45
30	7AT 250M-8	735	92	0,78	60	5,6	390	1,9	2,4	1,2448857	421	34	880	60
37	7AT 280S-8	735	92	0,79	75	5,6	480	1,9	2,4	1,9663295	560	40	880	75
45	7AT 280M-8	735	92,5	0,79	90	5,6	585	1,9	2,4	2,3594143	595	50	880	90
55	7AT 315S-8	740	93,5	0,81	105	5,5	710	1,9	2,4	4,5082333	805	62	890	105
75	7AT 315M-8	740	94,0	0,82	141	5,5	970	1,9	2,4	5,5602002	895	85	890	141
90	7AT 315LA-8	740	94,3	0,82	168	5,3	1160	1,8	2,3	6,7603580	980	102	890	168

# IE2 / 2 pol

P (kW)	Motor type	3000 min <sup>-1</sup>					400V/50Hz						
		n (min <sup>-1</sup> )	η 100% (%)	η 75% (%)	η 50% (%)	cos φ	I <sub>n</sub> (A)	$\frac{I_k}{I_n}$	$\frac{M_n}{(N_{mn})}$	$\frac{M_k}{M_n}$	$\frac{M_{max}}{M_n}$	J (kgm <sup>2</sup> )	m (kg)
0,75	5AT 80A-2	2840	77,5	77,4	74,5	0,81	1,72	5,2	2,5	2,6	2,9	0,00114	9
1,1	5AT 80B-2	2840	79,6	79,6	77,6	0,83	2,4	5,1	3,7	2,7	2,9	0,00080	9,2
1,5	5AT 90S-2	2840	81,6	81,6	79,6	0,78	3,4	5	5	2,8	3	0,00185	12
2,2	5AT 90L-2	2855	83,5	83,0	81,0	0,82	4,6	5,8	7,5	3	3,2	0,00185	14,7
3	5AT 100L-2	2880	84,8	84,0	81,9	0,85	6	6	10	3,5	3,8	0,00348	21
4	5AT 112M-2	2910	86,0	84,9	82,5	0,87	7,7	8,2	13	3,1	3,6	0,00557	26
5,5	7AT 132SA-2	2930	87,0	86,2	83,8	0,79	11,5	7,2	18	2,7	3,5	0,01097	39
7,5	7AT 132SB-2	2940	88,1	87,8	86,4	0,84	14,5	8,6	25	2,8	3,95	0,01426	46,5
11	7AT 160MA-2	2945	89,4	88,9	87,0	0,86	20,6	7,7	35	2,6	3,8	0,03233	73
15	7AT 160MB-2	2950	90,3	89,4	87,5	0,86	27,8	8,5	50	3,3	3,8	0,04477	83
18,5	7AT 160L-2	2955	90,3	89,9	88,2	0,86	34	8,7	60	3,1	3,5	0,05347	101
22	7AT 180M-2	2935	91,5	90,9	88,7	0,87	39,9	7,4	70	3,7	3,5	0,07185	185
30	7AT 200LA-2	2970	92,0	91,8	90,1	0,88	53,5	8,3	95	2,5	3	0,12407	220
37	7AT 200LB-2	2950	92,5	92,2	90,7	0,9	64	8,3	120	2,6	3	0,15509	237
45	7AT 225M-2	2960	92,9	92,9	91,9	0,89	78,5	7	145	2,3	2,8	0,23126	327
55	7AT 250M-2	2960	93,4	93,2	92,1	0,88	96,5	7,4	175	2,3	2,8	0,37820	385
75	7AT 280S-2	2975	94,0	93,2	92,1	0,84	137	9,6	240	2,7	2,9	0,61047	530
90	7AT 280M-2	2975	94,0	93,2	92,1	0,81	170	7,9	290	1,7	2	0,73256	640
110	7AT 315S-2	2975	94,3	93,6	92,4	0,9	187	8	355	1,7	2	1,44322	800
132	7AT 315M-2	2980	94,9	93,9	92,7	0,9	223	8	425	1,7	2	1,73186	845
160	7AT 315LA-2	2980	95,0	94,0	93,0	0,9	270	8	515	1,7	2	2,09923	895
200	7AT 315LB-2	2985	95,5	95,4	94,6	0,91	330	8	640	2,1	2,5	2,51908	1000

## IE2 / 4 pol

P (kW)	Motor type	1500 min <sup>-1</sup>					400V/50Hz						
		n (min <sup>-1</sup> )	η 100% (%)	η 75% (%)	η 50% (%)	cos φ	I <sub>n</sub> (A)	$\frac{I_k}{I_n}$	$\frac{M_n}{N_{mn}}$	$\frac{M_k}{M_n}$	$\frac{M_{max}}{M_n}$	J (kgm <sup>2</sup> )	m (kg)
0,75	5AT 80B-4	1415	79,7	80,0	78,5	0,72	1,88	4,5	5	2,6	2,7	0,00157	11
1,1	5AT 90S-4	1420	81,4	81,5	79,5	0,73	2,65	5,2	7,5	3	3,2	0,00284	12,5
1,5	5AT 90L-4	1420	83,0	82,8	80,7	0,74	3,5	5,8	10	3,4	3,8	0,00395	17,5
2,2	5AT 100LA-4	1435	84,3	83,0	81,0	0,7	5,35	6	15	3,4	3,7	0,00607	21
3	5AT 100LB-4	1425	85,5	83,5	81,4	0,75	6,7	6,7	20	3	4	0,00810	25
4	5AT 112M-4	1450	86,6	85,0	82,0	0,73	9,1	7,1	25	3,8	4,8	0,01389	38
5,5	7AT 132S-4	1455	88,0	87,3	84,5	0,82	11	7,7	35	3,3	3,6	0,02762	50
7,5	7AT 132M-4	1455	88,9	88,0	85,6	0,81	15	7,9	50	3,6	4,1	0,03499	57
11	7AT 160M-4	1470	89,9	88,9	86,5	0,76	23	7,1	70	3,2	3,7	0,06116	80
15	7AT 160L-4	1465	90,7	89,8	87,0	0,82	29	7,85	100	3,3	3,8	0,08792	109
18,5	7AT 180M-4	1460	91,2	91,6	90,0	0,83	35	7,3	120	3,2	3,6	0,12615	183
22	7AT 180L-4	1460	91,6	92,0	91,0	0,82	42	7,5	145	3,2	3,6	0,17030	199
30	7AT 200L-4	1475	92,3	92,4	91,4	0,84	55,9	7,6	195	3,3	3,5	0,24296	268
37	7AT 225S-4	1475	92,7	92,7	92,2	0,85	67,5	7,6	240	2,7	2,9	0,38249	322
45	7AT 225M-4	1475	93,1	93,1	92,5	0,83	84	7,6	290	2,8	3	0,46218	354
55	7AT 250M-4	1480	93,5	93,5	92,7	0,86	98,5	7,8	355	2,8	3	0,71774	475
75	7AT 280S-4	1485	94,1	93,6	93,0	0,82	140	7,5	480	2,4	2,8	1,18667	620
90	7AT 280M-4	1485	94,5	93,7	93,1	0,84	164,5	6,8	580	2,1	2,5	1,42400	680
110	7AT 315S-4	1485	94,5	93,7	93,1	0,84	200	5,6	710	1,5	2,2	2,51257	930
132	7AT 315M-4	1485	95,2	94,8	93,9	0,84	239	5,6	850	1,5	2,2	3,09883	945
160	7AT 315LA-4	1490	95,5	95,0	94,2	0,82	295	5,6	1025	1,5	2,2	3,68510	1080
200	7AT 315LB-4	1490	94,6	93,7	93,5	0,82	370	6,5	1280	1,7	2,2	4,43867	1180

# IE2 / 6 pol

P (kW)	Motor type	1000 min <sup>-1</sup>					400V/50Hz						
		n (min <sup>-1</sup> )	η 100% (%)	η 75% (%)	η 50% (%)	cos φ	I <sub>n</sub> (A)	$\frac{I_k}{I_n}$	$\frac{M_n}{(N_{mn})}$	$\frac{M_k}{M_n}$	$\frac{M_{max}}{M_n}$	J (kgm <sup>2</sup> )	m (kg)
0,75	5AT 90S-6	910	76,0	74,0	71,7	0,64	2,2	3,8	8	2,2	2,6	0,0028440	13,5
1,1	5AT 90L-6	910	78,2	77,8	75,3	0,7	2,9	3,7	12	2	2,3	0,0037920	17
1,5	5AT 100L-6	945	80,0	80,0	77,6	0,71	3,8	5	15	2,4	2,8	0,0104190	20
2,2	5AT 112M-6	935	82,0	81,5	79,1	0,71	5,45	4,6	22	2,2	2,5	0,0148410	30
3	7AT 132S-6	950	83,7	83,0	80,3	0,78	6,65	5,1	30	2,2	2,5	0,0314610	39
4	7AT 132MA-6	965	84,6	84,0	81,5	0,67	10,2	6	40	3	3,2	0,0377540	45
5,5	7AT 132MB-6	955	86,0	84,9	82,5	0,72	12,7	6,1	55	2,9	3,3	0,0453040	50
7,5	7AT 160M-6	970	87,2	86,8	84,7	0,76	16	7,1	75	2,6	3,5	0,0925210	78
11	7AT 160L-6	965	88,7	88,6	86,5	0,77	23,2	7,3	100	2,8	3,7	0,1261650	110
15	7AT 180L-6	970	89,7	89,6	88,8	0,85	28,5	6,7	150	2,1	2,8	0,1909080	165
18,5	7AT 200LA-6	970	90,4	89,2	88,8	0,77	38,5	6,7	180	2,2	3,3	0,2771130	255
22	7AT 200LB-6	970	90,9	89,8	89,0	0,8	44	6	215	2	2,8	0,3192800	265
30	7AT 225M-6	980	91,7	91,7	91,0	0,8	59	6,6	290	2,7	3	0,7262250	350
37	7AT 250M-6	985	92,2	92,2	91,0	0,8	72	7	360	2,5	2,7	1,0004050	395
45	7AT 280S-6	985	92,7	92,3	91,1	0,77	91	5,5	435	2,9	3,1	1,4674930	510
55	7AT 280M-6	985	93,5	92,6	91,3	0,77	110	7,8	535	2,5	3	1,7609950	550
75	7AT 315S-6	990	94,0	93,2	91,9	0,82	140	7,5	725	2,5	2,8	4,4698000	800
90	7AT 315M-6	985	94,2	93,3	91,9	0,81	170	7,5	875	2,5	2,8	5,5127460	865
110	7AT 315LA-6	985	94,4	93,5	92,0	0,82	205	7,5	1065	2,5	2,8	6,7046870	960
132	7AT 315LB-6	985	94,6	93,7	92,2	0,82	245	7,5	1280	2,5	2,8	8,194645	1050

# IE1/IE2 B3

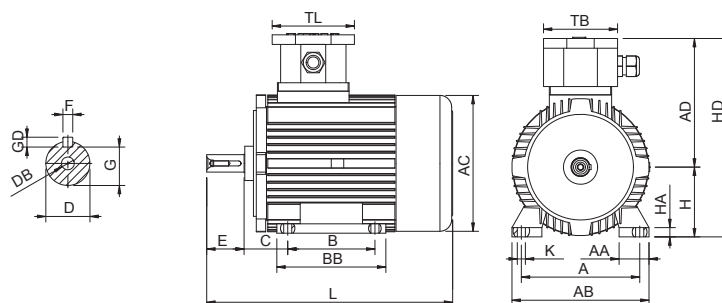

## 5AT and 7AT

Motor type												B3								
	AC	D	DB	E	F	G+GD	AD	L	TL	TB	LD	A	AA	AB	B	BB	C	H	HA	K

General dimensions

5AT 71	139	14j6	M5	30	5	16	164	249	135	135	269	112	33	140	90	110	45	71	8	7
5AT 80	156	19j6	M6	40	6	21,5	178	281	135	135	301	125	37	160	100	125	50	80	10	9
5AT 90S	176	24j6	M8	50	8	27	184	304	135	135	324	140	42	180	100	125	56	90	12	9
5AT 90L	176	24j6	M8	50	8	27	184	329	135	135	349	140	42	180	125	150	56	90	12	9
5AT 100	194	28j6	M10	60	8	31	184	373	135	135	393	160	47	200	140	175	63	100	14	13
5AT 112	218	28j6	M10	60	8	31	195	400	135	135	420	190	48	220	140	175	70	112	15	13
7AT 132S	258	38k6	M12	80	10	41	246	515	170	180	545	216	50	260	140	218	89	132	18	13
7AT 132M	258	38k6	M12	80	10	41	246	515	170	180	545	216	50	260	178	218	89	132	18	13
7AT 160M	318	42k6	M16	110	12	45	300	650	210	220	667	254	62	320	210	304	108	160	25	15
7AT 160L	318	42k6	M16	110	12	45	300	650	210	220	667	254	62	320	254	304	108	160	25	15
7AT 180M	348	48k6	M16	110	14	51,5	320	705	210	220	735	279	65	350	241	334	121	180	28	15
7AT 180L	348	48k6	M16	110	14	51,5	320	705	210	220	735	279	65	350	279	334	121	180	28	15
7AT 200	391	55m6	M20	110	16	59	342	790	250	275	880	318	75	398	305	360	133	200	30	18,5
7AT 225S	425	60m6	M20	140	18	64	360	865	250	275	960	356	82	436	286	370	149	225	30	18,5
7AT 225M-2	425	55m6	M20	110	16	59	360	835	250	275	930	356	82	436	311	370	149	225	30	18,5
4-8	425	60m6	M20	140	18	64	360	865	250	275	960	356	82	436	311	370	149	225	30	18,5
7AT 250M-2	471	60m6	M20	140	18	64	385	910	280	305	1010	406	100	500	349	415	168	250	35	24
4-8	471	65m6	M20	140	18	69	385	910	280	305	1010	406	100	500	349	415	168	250	35	24
7AT 280S-2	533	65m6	M20	140	18	69	435	1040	280	305	1150	457	112	555	368	533	190	280	40	24
4-8	533	75m6	M20	140	20	79,5	435	1040	280	280	1150	457	112	555	368	533	190	280	40	24
7AT 280M-2	533	65m6	M20	140	18	69	435	1040	280	305	1150	457	112	555	419	533	190	280	40	24
4-8	533	75m6	M20	140	20	79,5	435	1040	280	280	1150	457	112	555	419	533	190	280	40	24
7AT 315S-2	611	65m6	M20	140	18	69	495	1270	310	310	1380	508	120	628	406	586	216	315	45	28
4-8	611	80m6	M20	170	22	85	495	1300	310	310	1410	508	120	628	406	586	216	315	45	28
7AT 315M-2	611	65m6	M20	140	18	69	495	1270	310	310	1380	508	120	628	457	586	216	315	45	28
4-8	611	80m6	M20	170	22	85	495	1300	310	310	1410	508	120	628	457	586	216	315	45	28
7AT 315LA-2	611	65m6	M20	140	18	69	495	1270	310	310	1380	508	120	628	508	586	216	315	45	28
4-8	611	80m6	M20	170	22	85	495	1300	310	310	1410	508	120	628	508	586	216	315	45	28
7AT 315LB-2	611	65m6	M20	140	18	69	495	1350	310	310	1460	508	120	628	508	586	216	315	45	28
4-8	611	80m6	M20	170	22	85	495	1380	310	310	1490	508	120	628	508	586	216	315	45	28

# IE1/IE2 B5/B14

B5

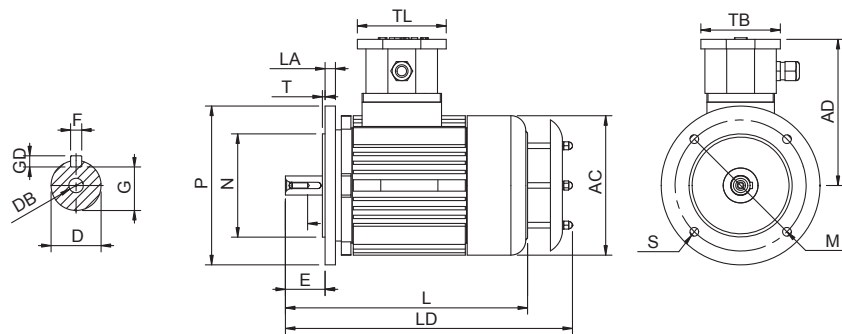

Motor type	B5						B14A – small						B14B – big					
	LA	M	N	P	S	T	LA	M	N	P	S	T	LA	M	N	P	S	T

5AT 71	10	130	110 j6	160	9	3	11	85	70 j6	105	M6	3	11	115	95 j6	140	M8	3,5
5AT 80	10	165	130 j6	200	11	3,5	13	100	80 j6	120	M6	3,5	13	130	110 j6	160	M8	3,5
5AT 90S, L	10	165	130 j6	200	11	3,5	13	115	95 j6	140	M8	3,5	13	130	110 j6	160	M8	3,5
5AT 100, 112	12	215	180 j6	250	15	4	15	130	110 j6	160	M8	3,5	15	165	130 j6	200	M10	3,5

7AT 132	12	265	230 j6	300	14	4	16	215	180 j6	250	M12	4						
7AT 160, 180	15	300	250 j6	350	18	5												
7AT 200	20	350	300 j6	400	19	5												
7AT 225	22	400	350 j6	450	19	5												
7AT 250, 280	22	500	450 j6	550	19	5												
7 AT 315	25	600	550 j6	660	24	6												

B14

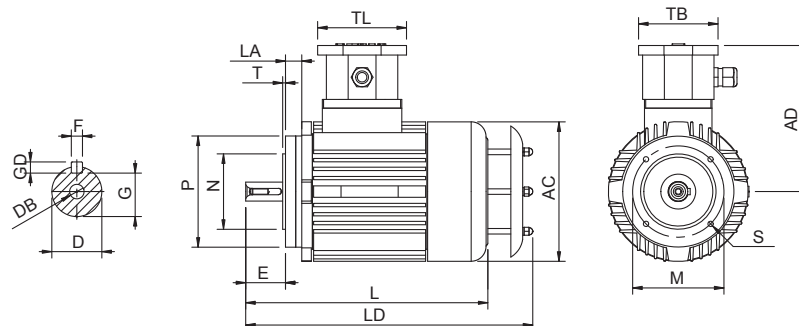



### Motors of AZS series in protection enclosure „e“ – increased safety

These motor series are applicable in zones 1 and 2, sites of use group II, where they during normal operation do not generate spark and have limited temperature rise. It is designed to avoid explosion risk in potentially explosive atmospheres. Protection consists of mechanical protection, improved insulation systems and electrical connections and limited temperature rise during normal operation.

Explosion protection is achieved when the certified motor versions interact with a similarly certified motor protection switch. The motor protection switch is selected in accordance with the values certified for the motor for the starting

current ratio  $ILR/I_{rated}$  and the  $tE$  times, so that in the case of a locked rotor fault, the motor is isolated from the supply within the  $tE$  time. The  $tE$  times assigned to the separate temperature classes and the starting current ratio are marked on the rating plate.

Designed according to IEC 60079-0, IEC 60079-7, IEC 60079-31. For these motor series we have Certificate of conformity from CESI (Italy) for explosive gases and flammable dusts.

All our increased safety motors series 5AZS are designed in the basic version for mains-fed operation for temperature classes T1 to T3/T4 at an ambient temperature from -20 to +40 °C.

#### Standard design

Series	5.xAZS 63 - 112 aluminum alloy die casted ribbed housing, die casted terminal box and bearing shields
Explosion protection	Ex II 2G Ex e IIC T3 Gb for GAS Option for DUST: Ex II 2D Ex tb IIC T135 °C Db IP66
Mounting designs	B3, B5, B35, B14, B34
Terminal box	Situated on the top, on motors with feet, viewed from motor drive end
Power range	0.25 - 3,6 kW
Duty	S1 (for ambient -20 °C to + 40 °C and up to 1000 m ASL)
Voltage and frequency	230/400V ± 10% Δ /Y (up to 2,2 kW), 400/690V ± 10% Δ/Y (3 kW and above) and 50Hz
Number of poles	Single-speed motors as 2 and 4
Protection index	IP 55
Cooling	IC 411
Insulation class	F (with rise in B)
Colour tone	RAL 9005 Black

## AZS series enclosure „e“

### Options

Special flanges

Shaft ends

Terminal box right or left

Protection index IP56, IP65, IP66

Other temperature class T4

Frequency inverter drive and screened cable resistant to benzine vapour

2 pol		3000 min <sup>-1</sup>					400V/50Hz				
P (kW)	Motor type	n (min <sup>-1</sup> )	η (%)	cos φ	I <sub>n</sub> (A)	tE (s)	$\frac{I_k}{I_n}$	$\frac{M_k}{M_n}$	$\frac{M_{max}}{M_n}$	J (kgm <sup>2</sup> )	m (kg)
0,25	5AZS 63B-2/T3	2860	70	0,75	0,75		5,0	3,4	3,8	0,000162	4,5
0,37	5AZS 71A-2/T3	2750	67	0,82	1	35	3,6	1,98	2,4	0,000350	5,8
0,5	5AZS 71B-2/T3	2800	72	0,78	1,3	20	4,18	2,4	2,8	0,000530	6,1
0,75	5AZS 80A-2/T3	2840	75	0,82	1,8	18	5,05	2,6	2,9	0,000930	9,3
1,1	5AZS 80B-2/T3	2810	75	0,81	2,6	12	4,7	2,4	2,7	0,001100	9,5
1,3	5AZS 90S-2/T3	2850	80	0,83	2,9	21	5,5	2,8	3	0,001500	12
1,85	5AZS 90L-2/T3	2860	83	0,83	4	14	6,6	3,6	3,6	0,002100	14,8
2,5	5AZS 100L-2/T3	2890	81	0,84	5,5	9	7,6	4,0	4,1	0,004000	20,8
3,3	5AZS 112M-2/T3	2915	86	0,85	6,6	15	8,7	3,5	3,8	0,006300	29,7

## 5AZS

4 pol		1500 min <sup>-1</sup>					400V/50Hz				
P (kW)	Motor type	n (min <sup>-1</sup> )	η (%)	cos φ	I <sub>n</sub> (A)	tE (s)	$\frac{I_k}{I_n}$	$\frac{M_k}{M_n}$	$\frac{M_{max}}{M_n}$	J (kgm <sup>2</sup> )	m (kg)
0,18	5AZS 63B-4/T3	1370	60	0,72	0,60		3,3	2,2	2,4	0,000248	4,5
0,25	5AZS 71A-4/T3	1380	61	0,66	0,9	41	3	2,1	2,3	0,000600	5,2
0,37	5AZS 71B-4/T3	1370	68	0,71	1,15	34	3,3	2	2,2	0,000850	6
0,55	5AZS 80A-4/T3	1395	74	0,72	1,5	27	4	2	2,4	0,001500	8,2
0,7	5AZS 80B-4/T4	1410	80	0,71	1,8	13	4,72	2,5	2,8	0,001600	9,6
0,75	5AZS 80B-4/T3	1400	77	0,74	1,9	30	4,47	2,3	2,6	0,001600	9,6
1	5AZS 90S-4/T3	1390	78	0,75	2,5	34	4,35	2,5	2,7	0,003300	11,6
1,35	5AZS 90L-4/T3	1400	79	0,78	3,2	27	4,78	2,5	2,7	0,004100	14,1
1,5	5AZS 90L-4/T3	1375	76	0,82	3,5	26,8	4,4	2,2	2,4	0,004100	14,1
2	5AZS 100LA-4/T3	1420	83	0,83	4,2	22	5,52	2,3	2,6	0,006500	19,7
2,5	5AZS 100LB-4/T3	1440	85	0,78	5,5	17	6,4	2,9	3,5	0,008750	24,5
3,6	5AZS 112M-4/T3	1440	86	0,77	6,6	10	7,6	3,3	3,7	0,001130	32,8

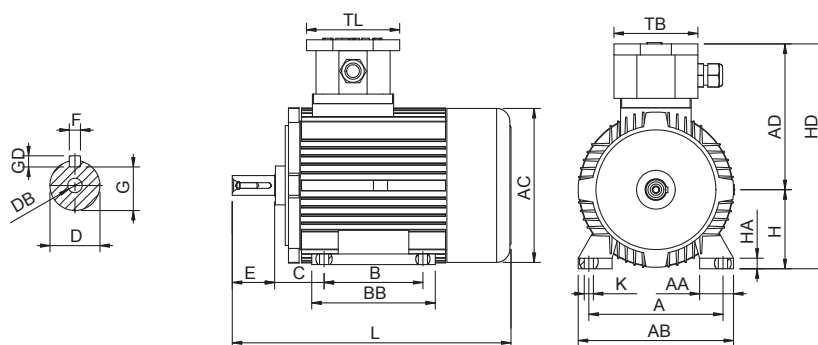

Motor type												B3									
	AC	D	DB	E	F	G+D	AD	L	TL	TB	LD	A	AA	AB	B	BB	C	H	HA	K	
General dimensions																					
5AZS 63	123	11j6	M4	23	4	12,5	112	214	100	100	229	100	22	120	80	105	40	63	10	7x12	
5AZS 71	139	14j6	M5	30	5	16	120	243	100	100	258	112	26	137	90	109	45	71	11	7x11	
5AZS 80	156	19j6	M6	40	6	21,5	142	277	110	110	292	125	36	160	100	125	50	80	11	8x16	
5AZS 90S	176	24j6	M8	50	8	27	148	307	110	110	324	140	41	170	100	130	56	90	13	9x16	
5AZS 90L	176	24j6	M8	50	8	27	148	332	110	110	349	140	41	175	125	155	56	90	13	9x16	
5AZS 100	194	28j6	M10	60	8	31	156	370	110	110	390	160	47	200	140	170	63	100	12	11x22	
5AZS 112	218	28j6	M10	60	8	31	167	400	110	110	420	190	40	220	140	177	70	112	14	11x22	

# AZS series enclosure „e“

B5

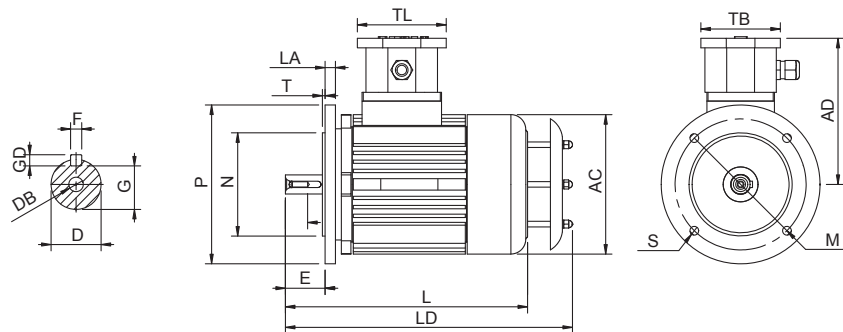

Motor type	B5						B14A small						B14B big					
	LA	M	N	P	S	T	LA	M	N	P	S	T	LA	M	N	P	S	T
5AZS 63	9	115	95j6	140	9,5	3	8	75	60j6	90	M5	3						
5AZS 71	10	130	110j6	160	9,5	3,5	8	85	70j6	105	M6	2,5	10	115	95j6	140	M8	3
5AZS 80	10	165	130j6	200	11,5	3,5	8	100	80j6	120	M6	3	10	130	110j6	160	M8	3,5
5AZS 90S	10	165	130j6	200	12	3,5	10	115	95j6	140	M8	3	10	130	110j6	160	M8	3,5
5AZS 90L	10	165	130j6	200	12	3,5	10	115	95j6	140	M8	3	10	130	110j6	160	M8	3,5
5AZS 100	15	215	180j6	250	15	4	10	130	110j6	160	M8	3	12	165	130j6	200	M10	3,5
5AZS 112	15	215	180j6	250	15	4	10	130	110j6	160	M8	3	12	165	130j6	200	M10	3,5

B14

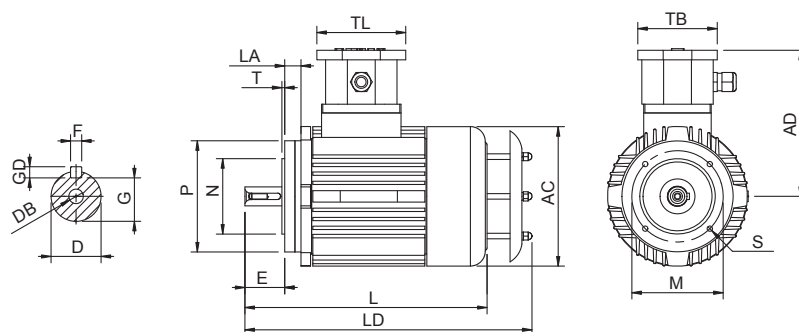

# Mounting positions

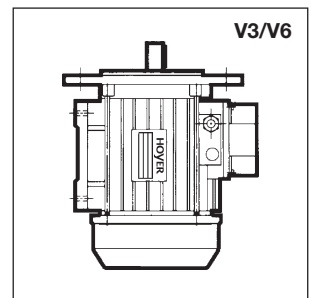
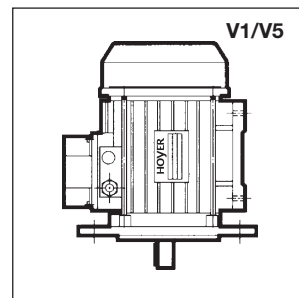
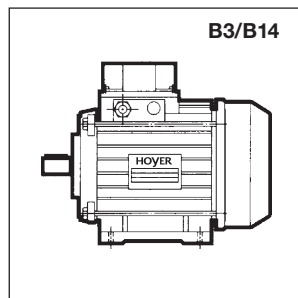
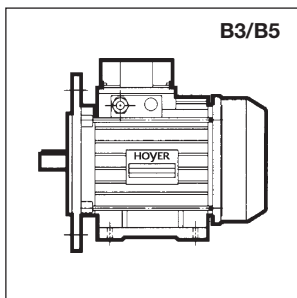
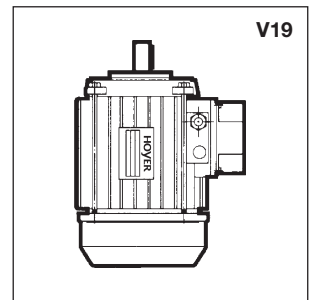
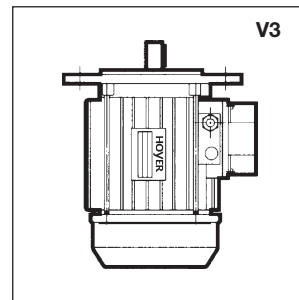
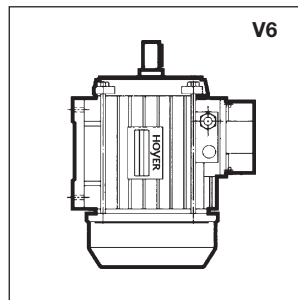
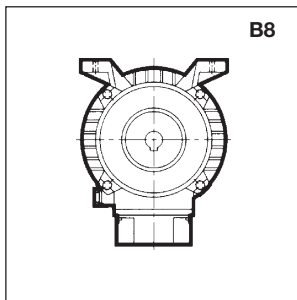
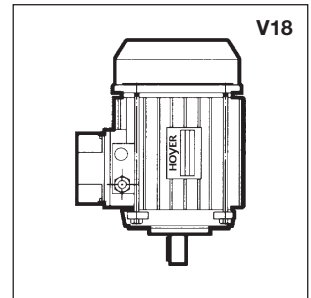
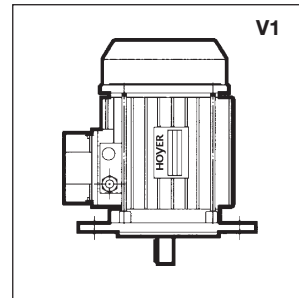
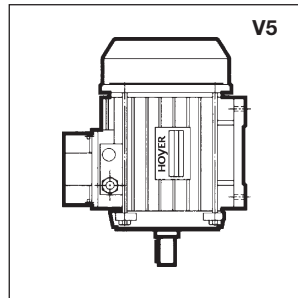
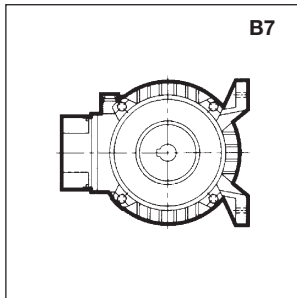
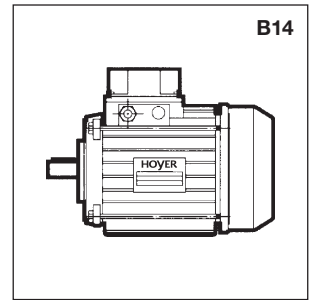
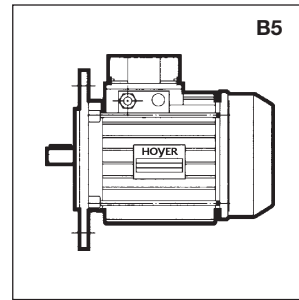
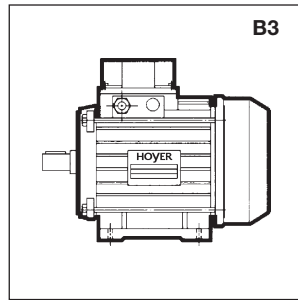
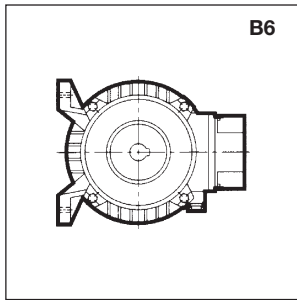



# HOYER

EXCEEDING EXPECTATIONS

Hoyer Motors, Explosion Proof Motors, October 2016

## Head Offices

Denmark  
 Over Hadstenvvej 42  
 DK-8370 Hadsten  
 T +45 86 98 21 11  
 F +45 86 98 17 79  
 hoyermotors@hoyermotors.com  
 hoyermotors.com

## Branch Offices

Germany  
 Landsberger Straße 155  
 80687 München  
 T +49 89 700 88 235  
 F +49 89 543 56 333  
 germany@hoyermotors.com  
 hoyermotors.com

Benelux  
 Vasteland 78  
 3011 BN, Rotterdam  
 T +31 10 420 35 20  
 F +31 10 420 44 51  
 benelux@hoyermotors.com  
 hoyermotors.com

Japan  
 Mizunobu Bldg 7F, 1-11-1  
 Kitasaiwai  
 Nishi-ku Yokohama  
 T +81 80 4830 4488  
 japan@hoyermotors.com  
 hoyermotors.com

## China

19 Jingwu Middle Road  
 Beilun District  
 Ningbo 315821 · Zhejiang  
 T +86 574 26 28 15 77  
 F + 86 574 2628 1573  
 hoyermotors@hoyermotors.cn  
 hoyermotors.cn

## Sweden

Liljeholmsstranden 5 · PO box 44017  
 SE-100 73 Stockholm  
 T + 46 8 446 877 13  
 F + 46 8 446 877 20  
 sweden@hoyermotors.com  
 hoyermotors.com

## Korea

302ho · Code square, 3150-1  
 Daejeo 2-dong · Gangseo-gu  
 Busan · Korea  
 T +82 51 996 0251  
 F +82 51 996 0252  
 korea@hoyermotors.com  
 hoyermotors.com