

**CRYOGENIC
2016**

Cryogenic Valves

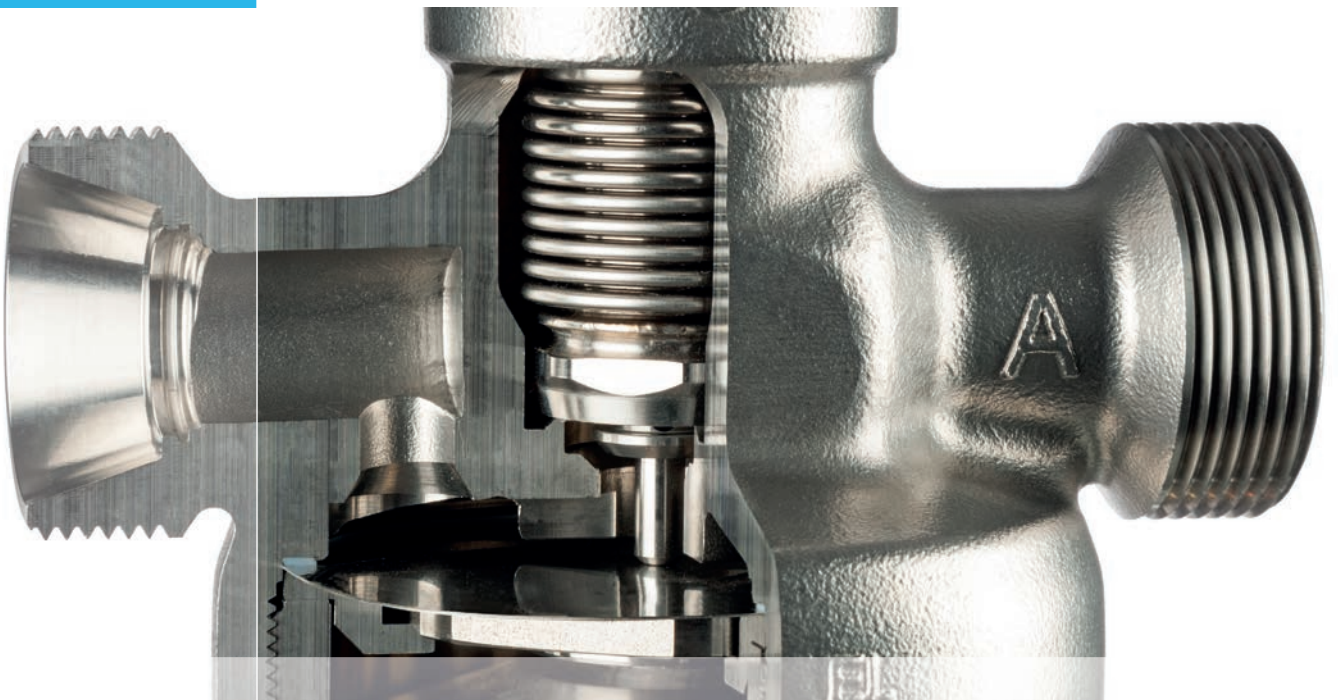

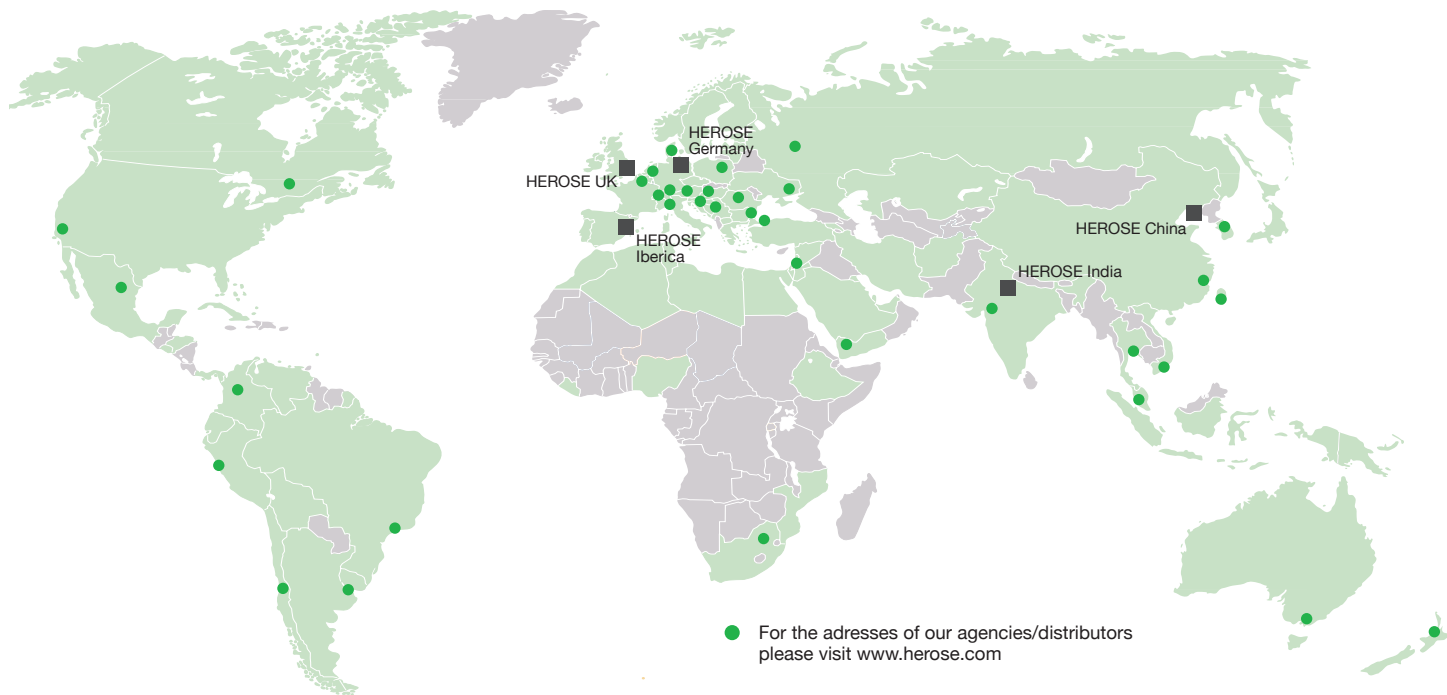

Headquarter Germany

HEROSE GMBH

Elly-Heuss-Knapp-Strasse 12
 23843 Bad Oldesloe
 Germany
 Phone: +49 4531 509-0
 Fax: +49 4531 509-120
 info@herose.com

International Subsidiaries

United Kingdom

HEROSE Ltd.
 3 Lindley Road
Finningley/Doncaster
 DN9 3DQ/U.K.
 Mr. Keith Stewart
 Phone: +44 1302 773 114
 Fax: +44 1302 773 333
 keith.stewart@herose.co.uk
www.herose.co.uk

Spain























HEROSE Iberica S.L.
 Deu i Mata, 117-121. 1-5.
08029 Barcelona, Spain
 Mr. Javier Gorriz
 Phone: +34 662 625-614
 Fax: +34 937 894-759
 ofertas@herose.es
www.herose.es

P.R. China

HEROSE Trading Co., Ltd.
 Wanda Road 41-16#, Building 33
 Jingang Industrial Park
 Dalian Economy & Technology
 Development Zone
Dalian 116600, China
 Mr. Guoyong Zhou
 Phone: +86 411 6616 4388
 Fax: +86 411 6616 4399
 info@herose.cn
www.herose.cn

India

HEROSE India
 IGEP Foundation, 630 - 636
 6th Floor, Apparel House
 Sector-44, Gurgaon
Haryana-122003 India
 Mr. Sankalp Tiwari
 Phone: +91 124 404 8273-77
 Mobile: +91 98 1839 0222
 tiwari.herose@igep.org
www.herose.com

Company	4	
Content	7	
Storage and Transportation of Cryogenic Gases	23	
Globe Valves	24	
Angle Valves	66	
Gate Valves	70	
Fill Cluster	74	
Spare Parts Valves and Fill Cluster	82	
Ball Valves	102	
Actuated Valves	110	
Accessories Actuated Valves	138	
Spare Parts Actuated Valves	158	
Pressure Regulator	160	
Check Valves	162	
Spare Parts Check Valves	177	
Strainer	180	
Spare Parts Strainer	195	
Safety Valves	196	
Overflow Valves	274	
Changeover Valves	278	
Firesafe and Offshore Applications	293	
Fire Safe Valves	294	
Offshore Valves	310	
Fire Safe and Offshore Valves	328	
Spare Parts Firesafe and Offshore Applications	341	
General Information	353	

Company

Throughout the world, HEROSE provides its customers with safety for handling technical gases, vapours and liquids in cryogenic applications and pressure vessels. With more than 140 years experience in the development, manufacture and sale of valves with a high level of innovation and modern production with certified quality management, HEROSE is one of the world's leading manufacturers of valves for industry and cryogenic applications. HEROSE employs around 200 employees and supplies to over 80 countries worldwide.



Products

HEROSE offers a complete product range of globe, check and control valves as well as safety valves for cryogenic liquefied industrial gases like oxygen, nitrogen, hydrogen at temperatures down to -270°C (3K) and for liquefied natural gas (LNG).

Additional HEROSE offers a large range of nonferrous safety valves for general industrial applications and DIN EN standard valves for engineering and plant construction industries.

High Quality

No compromise on material selection, production and functional testing guarantee a hundred percent consistently high quality „Made in Germany“.





Headquarter in Bad Oldesloe – on more than 10,000 m² production and office area nearly 400,000 valves are produced every year



Frequently HEROSE offers trainings with integrated test lab demonstrations



HEROSE supplies valves for a wide range of industrial gas storage vessels from 180 to 500,000 litres and for larger LNG-vessels built on site



HEROSE-industrial safety valves are also used in the air supply unit of the breaking system for the high speed train Velaro RUS



HEROSE-valves for oil cooled transformers are proved to be used under the extreme climatic conditions for power generation at offshore sites



Material analysis and identification during the incoming goods check



100 % tightness test of the valves at design pressure



Continuous quality checks within the scope of the operator self check

Product Catalogues at a glance

CRYOGENIC

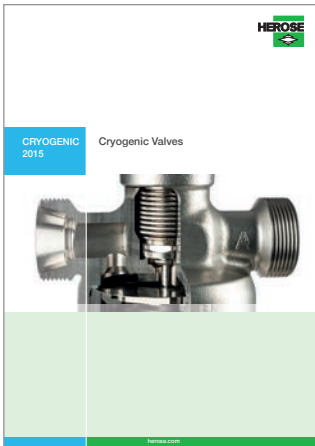

Valves and Safety Valves for

- Storage and Transportation of Cryogenic Gases
- Firesafe and Offshore Applications

INDUSTRY

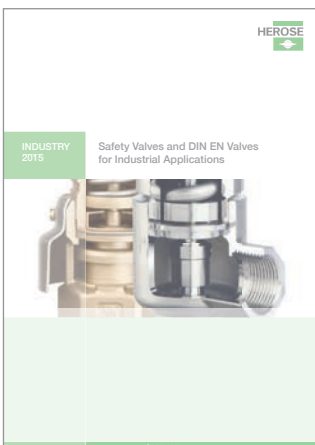

Valves for Industrial Applications

- Safety Valves and Overflow Valves
- DIN EN Valves

ENERGY



Valves for oil-immersed Transformers for

- Onshore Applications
- Offshore Applications
- Low Temperature Applications

Storage and Transportation of Cryogenic Gases

Content



Globe Valves

Type	Nominal size	Connections	Working pressure	Temperature	Page
01301	DN10 - DN50	Socket for copper stubs Socket for stainl. steel stubs	PN50	-196°C - +120°C 77K - 393K	24
01301	DN10 - DN50	Copper stubs	PN50	-196°C - +120°C 77K - 393K	25
01301	DN10 - DN50	Stainless steel stubs	PN50	-196°C - +120°C 77K - 393K	26
01305	DN10 - DN50	Thread type G (BSPP) Thread type R (BSPT) Thread type NPT	PN50	-196°C - +120°C 77K - 393K	27
02401	DN10 - DN50	Male thread	PN50	-196°C - +120°C 77K - 393K	28
02401	DN10 - DN50	Union type braze fittings for copper pipe	PN50	-196°C - +120°C 77K - 393K	29
02401	DN10 - DN50	Union type weld fittings for stainless steel pipe	PN50	-196°C - +120°C 77K - 393K	30
01331	DN10 - DN150	Butt weld connection Socket weld connection	PN50 (DN100/150=PN40)	-196°C - +120°C 77K - 393K	31
01335	DN10 - DN50	Thread type G (BSPP) Thread type R (BSPT) Thread type NPT	PN50	-196°C - +120°C 77K - 393K	32
03331	DN25 - DN100	Flanged DIN EN PN40	PN40	-196°C - +120°C 77K - 393K	33
03331	DN25 - DN100	Flanged ANSI class 300	class 300	-196°C - +120°C 77K - 393K	34
01351	DN10 - DN150	Butt weld connection, Socket weld connection	PN50 (DN100/150=PN40)	-196°C - +120°C 77K - 393K	35
01355	DN10 - DN50	Thread type G (BSPP) Thread type R (BSPT) Thread type NPT	PN50	-196°C - +120°C 77K - 393K	36
03351	DN25 - DN100	Flanged DIN EN PN40	PN40	-196°C - +120°C 77K - 393K	37
03351	DN25 - DN100	Flanged ANSI class 300	class 300	-196°C - +120°C 77K - 393K	38
01311	DN10 - DN50	Socket for copper stubs Socket for stainl. steel stubs	PN50	-196°C - +120°C 77K - 393K	39
01311	DN10 - DN50	Copper stubs	PN50	-196°C - +120°C 77K - 393K	40
01311	DN10 - DN50	Stainless steel stubs	PN50	-196°C - +120°C 77K - 393K	41
01315	DN10 - DN50	Thread type G (BSPP) Thread type R (BSPT) Thread type NPT	PN50	-196°C - +120°C 77K - 393K	42
02411	DN10 - DN50	Male thread	PN50	-196°C - +120°C 77K - 393K	43
02411	DN10 - DN50	Union type braze fittings for copper pipe	PN50	-196°C - +120°C 77K - 393K	44
02411	DN10 - DN50	Union type weld fittings for stainless steel pipe	PN50	-196°C - +120°C 77K - 393K	45
01321	DN10 - DN150	Butt weld connection Socket weld connection	PN50 (DN100/150=PN40)	-196°C - +120°C 77K - 393K	46

Storage and Transportation of Cryogenic Gases

Content



Globe Valves

Type	Nominal size	Connections	Working pressure	Temperature	Page
01325	DN10 - DN50	Thread type G (BSPP) Thread type R (BSPT) Thread type NPT	PN50	-196°C - +120°C 77K - 393K	47
03321	DN25 - DN150	Flanged DIN EN PN16	PN16	-196°C - +120°C 77K - 393K	48
03321	DN25 - DN100	Flanged DIN EN PN40	PN40	-196°C - +120°C 77K - 393K	49
03321	DN25 - DN100	Flanged ANSI class 300	class 300	-196°C - +120°C 77K - 393K	50
01341	DN10 - DN150	Butt weld connection, Socket weld connection	PN50 (DN100/150=PN40)	-196°C - +120°C 77K - 393K	51
01341	DN200	Butt weld connection, Socket weld connection	PN25	-196°C - +120°C 77K - 393K	52
01345	DN10 - DN50	Thread type G (BSPP) Thread type R (BSPT) Thread type NPT	PN50	-196°C - +120°C 77K - 393K	53
03341	DN25 - DN100	Flanged DIN EN PN40	PN40	-196°C - +120°C 77K - 393K	54
03341	DN25 - DN100	Flanged ANSI class 300	class 300	-196°C - +120°C 77K - 393K	55
01252	DN10 - DN50	Butt weld connection, Socket weld connection	PN50	-196°C - +120°C 77K - 393K	56
03252	DN25 - DN50	Flanged DIN EN PN40	PN40	-196°C - +120°C 77K - 393K	57
03252	DN25 - DN50	Flanged ANSI class 300	class 300	-196°C - +120°C 77K - 393K	58
01420	DN15 - DN50	Butt weld connection	PN50	-196°C - +120°C 77K - 393K	59
1114	DN15 - DN50	Butt weld connection Socket weld connection	PN50	-196°C - +120°C 77K - 393K	60-62
1116	DN15 - DN50	Butt weld connection Socket weld connection	PN50	-196°C - +120°C 77K - 393K	63-65

Angle Valves

Type	Nominal size	Connections	Working pressure	Temperature	Page
01332	DN15 - DN50	Butt weld connection Socket weld connection	PN50	-196°C - +120°C 77K - 393K	66
01352	DN15 - DN50	Butt weld connection Socket weld connection	PN50	-196°C - +120°C 77K - 393K	67
01322	DN15 - DN50	Butt weld connection Socket weld connection	PN50	-196°C - +120°C 77K - 393K	68
01342	DN15 - DN50	Butt weld connection Socket weld connection	PN50	-196°C - +120°C 77K - 393K	69

Storage and Transportation of Cryogenic Gases

Content

HEROSE



Gate Valves

Type	Nominal size	Connections	Working pressure	Temperature	Page
09340	DN25 - DN100	Butt weld connection, Socket weld connection	PN50	-196°C - +120°C 77K - 393K	70
09345	DN25 - DN65	Thread type G (BSPP) Thread type R (BSPT) Thread type NPT	PN50	-196°C - +120°C 77K - 393K	71
09440	DN25 - DN65	Male thread	PN50	-196°C - +120°C 77K - 393K	72
09440	DN25 - DN100	Union type weld fittings for stainless steel pipe	PN50	-196°C - +120°C 77K - 393K	73

Fill Cluster

Type	Nominal size	Connections	Working pressure	Temperature	Page
07003	DN25 - DN40	Inlet: female thread Outlet: 2x stainless steel pipes	PN50	-196°C - +120°C 77K - 393K	74
07004	DN25 - DN40	Inlet: Mueller flange Outlet: 2x stainless steel pipes	PN50	-196°C - +120°C 77K - 393K	75
07015	DN25 - DN40	Inlet: Air Liquide flange Outlet: socket weld conn.	PN50	-196°C - +120°C 77K - 393K	76
07015	DN25 - DN40	Inlet: Air Liquide flange Outlet: socket weld conn.	PN50	-196°C - +120°C 77 conn.K - 393K	77
07012	DN25 - DN40	Inlet: Flange DIN EN PN40 Outlet: socket weld conn.	PN40	-196°C - +120°C 77K - 393K	78
07017	DN25 - DN40	Inlet: Air Liquide flange Outlet: socket weld conn.	PN50	-196°C - +120°C 77K - 393K	79
07017	DN25 - DN40	Inlet: Air Liquide flange Outlet: socket weld conn.	PN50	-196°C - +120°C 77K - 393K	80
070XX	DN25 - DN40	Flow rates Fill Cluster			81

Spare Parts Valves and Fill Cluster

Type	Specification	Nominal size	Suitable for Valve type	Page
28203	Disc complete, brass	DN10 - DN150	01301, 01305, 01311, 01315, 01321, 01322, 01325, 01331, 01332, 01335, 02401, 02411, 03321, 03331	82
28203	Disc complete, stainless steel	DN10 - DN200	01341, 01342, 01345, 01351, 01352, 01353, 01355, 03341, 03351	82
28203	Check disc complete, brass	DN10 - DN150	01301, 01305, 01311, 01315, 01321, 01322, 01325, 01331, 01332, 01335, 02401, 02411, 03321, 03331	83
28205	Check disc complete, stainless steel	DN10 - DN150	01341, 01342, 01345, 01351, 01352, 01355, 03341, 03351	83
29240	Disc complete, brass	DN25 - DN100	09340, 09343, 09443	84
29256	Wedge complete	DN25 - DN100	09340, 09343, 09443	85
28301	Topwork, bronze	DN10 - DN150	01301, 01305, 01331, 01335, 02401, 03331	86
28351	Topwork, stainless steel	DN10 - DN150	01351, 01355, 03351	87
28311	Topwork, bronze	DN10 - DN150	01311, 01315, 01321, 01325, 02411, 03321, 07003, 07004	88
28341	Topwork, stainless steel	DN10 - DN200	01341, 01345, 03341	89

Spare Parts Valves and Fill Cluster

Type	Specification	Nominal size	Suitable for Valve type	Page
28302	Topwork angle type, bronze	DN15 - DN50	01332	90
28352	Topwork angle type, stainless steel	DN15 - DN50	01352	91
28312	Topwork angle type, bronze	DN15 - DN50	01322, 07003, 07004, 07015	92
28342	Topwork angle type, stainless steel	DN15 - DN50	01342, 07017	93
29340	Topwork gate valve, stainless steel	DN25 - DN100	09340	94
30000	Sealing spare part kit	DN10 - DN150	01301, 01305, 01311, 01315, 01321, 01322, 01325, 01331, 01332, 01335, 01353, 02401, 02411, 03321, 03331	95
30290	Sealing spare part kit	DN25 - DN100	09340, 09345, 09440	96
30293	Sealing spare part kit	DN25 - DN100	09343, 09443	97
30341	Sealing spare part kit	DN10 - DN200	01341, 01342, 01345, 01351, 01352, 01355, 03341, 03351	98
31514	Disc sealing spare part kit	DN10 - DN150	01301, 01305, 01311, 01315, 01321, 01322, 01325, 01331, 01332, 01335, 01341, 01342, 01345, 01351, 01352, 01355, 02401, 02411, 03321, 03331, 03341, 03351	99
55317, 55318	Handwheel	DN10 - DN200	alle handbetätigten Armaturen	100
55579	Valve safety catch capsule	DN15 - DN150	alle handbetätigten Armaturen	101

Ball Valves

Type	Nominal size	Connections	Working pressure	Temperature	Page
15070, 15071	DN8 - DN150	Socket weld connection, Butt weld connection	PN16 - PN100	-50°C - +190°C 223K - 463K	102
15072, 15073	DN8 - DN100	Thread type NPT, Thread type G	PN25 - PN100	-50°C - +190°C 223K - 463K	103
15080, 15081	DN8 - DN150	Socket weld connection, Butt weld connection	PN16 - PN100	-50°C - +190°C 223K - 463K	104
15082, 15083	DN8 - DN100	Thread type NPT, Thread type G	PN25 - PN100	-50°C - +190°C 223K - 463K	105
15080, 15081	DN8 - DN100	Socket weld connection, Butt weld connection	PN25 - PN100	-200°C - +200°C 73K - 473K	106
15082, 15083	DN8 - DN100	Thread type NPT, Thread type G	PN25 - PN100	-200°C - +200°C 73K - 473K	107
15085, 15086	DN15 - DN150	Socket weld connection, Butt weld connection	PN25 - PN100	-50°C - +190°C 223K - 463K	108
15085, 15086	DN15 - DN125	Socket weld connection, Butt weld connection	PN25 - PN100	-200°C - +200°C 73K - 473K	109

Storage and Transportation of Cryogenic Gases

Content



Actuated Valves

Type	Nominal size	Connections	Working pressure	Temperature	Page
01313	DN10 - DN50	Socket for copper stubs Socket for stainl. steel stubs	PN50	-196°C - +120°C 77K - 393K	110
01313	DN10 - DN50	Stainless steel stubs	PN50	-196°C - +120°C 77K - 393K	111
01314	DN10 - DN50	Thread type G, Thread type NPT	PN50	-196°C - +120°C 77K - 393K	112
02413	DN10 - DN50	Male thread	PN50	-196°C - +120°C 77K - 393K	113
01343	DN10 - DN150	Butt weld connection, Socket weld connection	PN50 (DN100/150=PN40)	-196°C - +120°C 77K - 393K	114
01343	DN10 - DN150	Butt weld connection, Socket weld connection, Thread type G (BSPP) Thread type NPTF	PN50 (DN100/150=PN40)	-196°C - +120°C 77K - 393K	115-117
03323	DN25 - DN150	Flanged DIN EN PN16	PN16	-196°C - +120°C 77K - 393K	118
03323	DN25 - DN150	Flanged DIN EN PN40	PN40	-196°C - +120°C 77K - 393K	119
03323	DN25 - DN150	Flanged ANSI class 300	class 300	-196°C - +120°C 77K - 393K	120
03343	DN25 - DN150	Flanged DIN EN PN16	PN16	-196°C - +120°C 77K - 393K	121
03343	DN25 - DN150	Flanged DIN EN PN40	PN40	-196°C - +120°C 77K - 393K	122
03343	DN25 - DN150	Flanged ANSI class 300	class 300	-196°C - +120°C 77K - 393K	123
01343	DN15 - DN100	Butt weld connection, Socket weld connection	PN50 (DN100=PN40)	-196°C - +120°C 77K - 393K	124/125
27100	DN10 - DN150	Electric actuator for globe valves		-20°C - +60°C 253K - 333K	126
27511	DN10 - DN150	Pneumatic actuator for globe valves, spring to close		-20°C - +80°C 253K - 353K	127
27511	DN10 - DN150	Pneumatic actuator for control valves, spring to close		-20°C - +80°C 253K - 353K	128

Storage and Transportation of Cryogenic Gases

Content



Actuated Valves

Type	Nominal size	Connections	Working pressure	Temperature	Page
27512	DN10 - DN150	Pneumatic actuator for globe valves, spring to open		-20°C - +80°C 253K - 353K	129
27512	DN10 - DN150	Pneumatic actuator for control valves, spring to open		-20°C - +80°C 253K - 353K	130
27514	DN10 - DN150	Pneumatic actuator for globe valves, spring to close		-40°C - +100°C 233K - 373K	131
27514	DN10 - DN150	Pneumatic actuator for control valves, spring to close		-40°C - +100°C 233K - 373K	132
27515	DN10 - DN150	Pneumatic actuator for globe valves, spring to open		-40°C - +100°C 233K - 373K	133
27515	DN10 - DN150	Pneumatic actuator for control valves, spring to open		-40°C - +100°C 233K - 373K	134
01353	DN15 - DN80	Butt weld connection, Socket weld connection	PN50	-196°C - +120°C 77K - 393K	135
09343	DN25 - DN100	Butt weld connection, Socket weld connection	PN50	-196°C - +120°C 77K - 393K	136
09443	DN25 - DN100	Butt weld connection, Socket weld connection	PN50	-196°C - +120°C 77K - 393K	137

Storage and Transportation of Cryogenic Gases

Content



Accessories Actuated Valves

Type	Specification	Temperature	Page
40060	Solenoid valve	-30°C - +90°C 243K - 363K	138
41060	Solenoid valve	-30°C - +90°C 243K - 363K	139
40061	Solenoid valve EEx	0°C - +70°C 273K - 343K	140
41061	Solenoid valve EEx	0°C - +70°C 273K - 343K	141
41060	Solenoid valve, suitable for oxygen	0°C - +90°C 273K - 363K	142
40070, 40071	Position and limit switches	-20°C - +80°C 253K - 353K	143
41070, 41071	Position and limit switches	-20°C - +80°C 253K - 353K	144
40080	Inductive proximity switches	-25°C - +70°C 248K - 343K	145
41080	Inductive proximity switches	-25°C - +70°C 248K - 343K	146
08002	Air control sets	-50°C - +90°C 223K - 363K	147
08003	Air control sets	-50°C - +90°C 223K - 363K	148
40090	Electropneumatic positioner	-30°C - +80°C 243K - 353K	149
41090	Electropneumatic positioner	-30°C - +80°C 243K - 353K	150
40091	Electropneumatic positioner EEx	-30°C - +50°C 243K - 323K	151
41091	Electropneumatic positioner EEx	-30°C - +50°C 243K - 323K	152
40090	Pneumatic positioner	-40°C - +80°C 233K - 353K	153
41090	Pneumatic positioner	-40°C - +80°C 233K - 353K	154
40281	Inductive proximity switches EEx-box	-40°C - +80°C 233K - 353K	155
41281	Inductive proximity switches EEx-box	-40°C - +80°C 233K - 353K	156
74394	Bracket for accessories	-196°C - +120°C 77K - 393K	157

Spare Parts Actuated Valves

Type	Specification	Nominal size	Suitable for Valve type	Page
29343	Topwork gate valve, stainless steel	DN25 - DN100	09343, 09443	158
30003	Spare part kit	DN15 - DN100	01353, 01653, 01753, 01853, 09343, 09443	159

Storage and Transportation of Cryogenic Gases

Content



Pressure Regulator

Type	Nominal size	Connections	Working pressure	Temperature	Page
4186	DN20	Male thread Thread type G (BSPP) Thread type NPT	PN50	-196°C - +200°C 77K - 473K	160/161

Check Valves

Type	Nominal size	Connections	Opening pressure	Working pressure	Temperature	Page
05412	DN10 - DN50	Socket for copper stubs Socket for stainl. steel stubs	ca. 0,1 bar	PN50	-196°C - +120°C 77K - 393K	162
05412	DN10 - DN50	Copper stubs	ca. 0,1 bar	PN50	-196°C - +120°C 77K - 393K	163
05412	DN10 - DN50	Stainless steel stubs	ca. 0,1 bar	PN50	-196°C - +120°C 77K - 393K	164
05413	DN10 - DN50	Thread type G (BSPP) Thread type R (BSPT) Thread type NPT	ca. 0,1 bar	PN50	-196°C - +120°C 77K - 393K	165
05411	DN10 - DN50	Male thread	ca. 0,1 bar	PN50	-196°C - +120°C 77K - 393K	166
05411	DN10 - DN50	Union type braze fittings for copper pipe	ca. 0,1 bar	PN50	-196°C - +120°C 77K - 393K	167
05411	DN10 - DN50	Union type weld fittings for stainless steel pipe	ca. 0,1 bar	PN50	-196°C - +120°C 77K - 393K	168
05416	DN10 - DN150	Butt weld connection, Socket weld connection	ca. 0,1 bar	PN50 (DN100/150=PN40)	-196°C - +120°C 77K - 393K	169
05415	DN10 - DN50	Thread type G (BSPP) Thread type R (BSPT) Thread type NPT	ca. 0,1 bar	PN50	-196°C - +120°C 77K - 393K	170
05418	DN25 - DN100	Flanged DIN EN PN40	ca. 0,1 bar	PN40	-196°C - +120°C 77K - 393K	171
05418	DN25 - DN100	Flanged ANSI class 300	ca. 0,1 bar	class 300	-196°C - +120°C 77K - 393K	172
05414	DN10 - DN150	Butt weld connection, Socket weld connection	ca. 0,1 bar	PN50 (DN100/150=PN40)	-196°C - +120°C 77K - 393K	173
05417	DN10 - DN50	Thread type G (BSPP) Thread type R (BSPT) Thread type NPT	ca. 0,1 bar	PN50	-196°C - +120°C 77K - 393K	174
05419	DN25 - DN100	Flanged DIN EN PN40	ca. 0,1 bar	PN40	-196°C - +120°C 77K - 393K	175
05419	DN25 - DN100	Flanged ANSI class 300	ca. 0,1 bar	class 300	-196°C - +120°C 77K - 393K	176

Spare Parts Check Valves

Type	Specification	Nominal size	Suitable for Valve type	Page
28205	Check disc complete, brass	DN10 - DN150	05411, 05412, 05413, 05415, 05416, 05418	177
28206	Check disc complete, stainless steel	DN10 - DN150	05414, 05417, 05419	177
30514	Sealing spare part kit	DN10 - DN150	05411, 05412, 05413, 05414, 05415, 05416, 05417, 05418, 05419	178
31514	Disc sealing spare part kit	DN10 - DN100	05411, 05412, 05413, 05414, 05415, 05416, 05417, 05418, 05419	179

Storage and Transportation of Cryogenic Gases

Content



Strainer

Type	Nominal size	Connections	Mesh size	Working pressure	Temperature	Page
08411	DN10 - DN50	Male thread	0,25 mm	PN50	-196°C - +120°C 77K - 393K	180
08411	DN10 - DN50	Union type braze fittings for copper pipe	0,25 mm	PN50	-196°C - +120°C 77K - 393K	181
08411	DN10 - DN50	Union type weld fittings for stainless steel pipe	0,25 mm	PN50	-196°C - +120°C 77K - 393K	182
08412	DN10 - DN50	Socket for copper stubs Socket for stainl. steel stubs	0,25 mm	PN50	-196°C - +120°C 77K - 393K	183
08412	DN10 - DN50	Copper stubs	0,25 mm	PN50	-196°C - +120°C 77K - 393K	184
08412	DN10 - DN50	Stainless steel stubs	0,25 mm	PN50	-196°C - +120°C 77K - 393K	185
08413	DN10 - DN50	Thread type G (BSPP) Thread type R (BSPT) Thread type NPT	0,25 mm	PN50	-196°C - +120°C 77K - 393K	186
08414	DN10 - DN150	Butt weld connection, Socket weld connection	0,25 mm	PN50 (DN100/150=PN40)	-196°C - +120°C 77K - 393K	187
08415	DN10 - DN50	Thread type G (BSPP) Thread type R (BSPT) Thread type NPT	0,25 mm	PN50	-196°C - +120°C 77K - 393K	188
08431	DN25 - DN100	Flanged DIN EN PN40	0,25 mm	PN40	-196°C - +120°C 77K - 393K	189
08431	DN25 - DN100	Flanged ANSI class 300	0,25 mm	class 300	-196°C - +120°C 77K - 393K	190
08417	DN10 - DN150	Butt weld connection, Socket weld connection	0,25 mm	PN50 (DN100/150=PN40)	-196°C - +120°C 77K - 393K	191
08416	DN10 - DN50	Thread type G (BSPP) Thread type R (BSPT) Thread type NPT	0,25 mm	PN50	-196°C - +120°C 77K - 393K	192
08432	DN25 - DN100	Flanged DIN EN PN40	0,25 mm	PN40	-196°C - +120°C 77K - 393K	193
08432	DN25 - DN100	Flanged ANSI class 300	0,25 mm	class 300	-196°C - +120°C 77K - 393K	194

Spare Parts Strainer

Type	Specification	Nominal size	Suitable for Valve type	Page
30800, 30801	Strainer screen, Filter	DN10 - DN200	08412, 08413, 08414, 08415, 08416, 08417, 08431, 08432, 08716, 08717	195

Storage and Transportation of Cryogenic Gases

Content



Abbreviations: in column Medium - type tested for
S = Steams, **G** = Gases, **L** = Liquids

Safety Valves

Type	Inlet	Medium	Temperature	Set pressure range	Approval		Page
					TÜV-SV	ASME	
06001 gastight	Male thread 1/4" up to 1/2"	S/G/L	-196°C - +65°C 77K - 338K	5,0 - 55,0 bar 72,5 - 797,7 PSI	1048		196/197
06002, 06206	Male thread 1/4" up to 1/2"	S/G	-196°C - +150°C 77K - 423K	1,0 - 55,0 bar 14,5 - 797,7 PSI	1048		198/199
06002 gastight	Male thread 1/4" up to 1/2"	S/G	-196°C - +150°C 77K - 423K	1,0 - 55,0 bar 14,5 - 797,7 PSI	1048		200/201
06011 gastight	Male thread 1/4" up to 1/2"	S/G/L	-196°C - +65°C 77K - 338K	5,0 - 55,0 bar 72,5 - 797,7 PSI	1048		202/203
06012, 06016	Male thread 1/4" up to 1/2"	S/G	-196°C - +150°C 77K - 423K	1,0 - 55,0 bar 14,5 - 797,7 PSI	1048		204/205
06012 gastight	Male thread 1/4" up to 1/2"	S/G	-196°C - +150°C 77K - 423K	1,0 - 55,0 bar 14,5 - 797,7 PSI	1048		206/207
06472	Male thread 1/4" up to 3/4"	S/G	-196°C - +150°C 77K - 423K	0,5 - 6,0 bar 7,3 - 87,0 PSI	836		208/209
06477	Male thread 1/4" up to 3/4"	S/G	-196°C - +150°C 77K - 423K	0,5 - 6,0 bar 7,3 - 87,0 PSI	836		210/211
06474	Male thread 1/4" up to 3/4"	S/G	-196°C - +150°C 77K - 423K	4,5 - 45,0 bar 65,3 - 652,6 PSI	836		212/213
06478	Male thread 1/4" up to 3/4"	S/G	-196°C - +150°C 77K - 423K	4,5 - 45,0 bar 65,3 - 652,6 PSI	836		214/215
06386	Male thread 1/2" up to 1"	S/G	-196°C - +185°C 77K - 458K	0,2 - 40,0 bar 2,9 - 580,1 PSI	780		216/217
06416	Male thread 1/2" up to 1"	S/G	-196°C - +185°C 77K - 458K	0,2 - 40,0 bar 2,9 - 580,1 PSI	780		218/219
06387	Female thread 1/2"	S/G	-196°C - +185°C 77K - 458K	0,2 - 25,0 bar 2,9 - 362,6 PSI	780		220/221
06417	Female thread 1/2"	S/G	-196°C - +185°C 77K - 458K	0,2 - 25,0 bar 2,9 - 362,6 PSI	780		222/223
06388	Male thread 1/2" up to 2"	S/G	-196°C - +185°C 77K - 458K	2,0 - 50,0 bar 29,0 - 725,1 PSI	780	✓	224-227
06418	Male thread 1/2" up to 2"	S/G	-196°C - +185°C 77K - 458K	2,0 - 50,0 bar 29,0 - 725,1 PSI	780	✓	228-231
06381	Male thread 1/2" up to 3/4"	S/G	-196°C - +185°C 77K - 458K	0,2 - 25,0 bar 2,9 - 362,6 PSI	780		232/233
06383	Male thread 1/2" up to 2"	S/G	-196°C - +185°C 77K - 458K	2,0 - 50,0 bar 29,0 - 725,1 PSI	780	✓	234/235
06413	Male thread 1/2" up to 2"	S/G	-196°C - +185°C 77K - 458K	2,0 - 50,0 bar 29,0 - 725,1 PSI	780	✓	236/237
06420	Male thread 1/2" up to 1-1/4"	S/G	-196°C - +185°C 77K - 458K	0,4 - 50,0 bar 5,8 - 725,1 PSI	1111		238/239
06425	Male thread 1/2" up to 1-1/4"	S/G	-196°C - +185°C 77K - 458K	0,4 - 50,0 bar 5,8 - 725,1 PSI	1111		240/241
06421	Female thread 1/2" up to 1-1/4"	S/G	-196°C - +185°C 77K - 458K	0,4 - 50,0 bar 5,8 - 725,1 PSI	1111		242/243
06426	Female thread 1/2" up to 1-1/4"	S/G	-196°C - +185°C 77K - 458K	0,4 - 50,0 bar 5,8 - 725,1 PSI	1111		244/245

Storage and Transportation of Cryogenic Gases

Content



Safety Valves

Type	Inlet	Medium	Temperature	Set pressure range	Approval		Page
					TÜV-SV	ASME	
06440	Male thread 1/2" up to 1-1/4"	S/G	-196°C - +185°C 77K - 458K	0,4 - 50,0 bar 5,8 - 725,1 PSI	1111		246/247
06445	Male thread 1/2" up to 1-1/4"	S/G	-196°C - +185°C 77K - 458K	0,4 - 50,0 bar 5,8 - 725,1 PSI	1111		248/249
06441	Female thread 1/2" up to 1-1/4"	S/G	-196°C - +185°C 77K - 458K	0,4 - 50,0 bar 5,8 - 725,1 PSI	1111		250/251
06446	Female thread 1/2" up to 1-1/4"	S/G	-196°C - +185°C 77K - 458K	0,4 - 50,0 bar 5,8 - 725,1 PSI	1111		252/253
06801	Male thread 1/2" up to 1"	S/G/L d ₀ =12,5 S/G	-270°C - +225°C 3K - 498K	3,0 - 25,0 bar 43,5 - 362,6 PSI	1105		254/255
06806	Male thread 1/2" up to 1"	S/G/L d ₀ =12,5 S/G	-270°C - +225°C 3K - 498K	3,0 - 25,0 bar 43,5 - 362,6 PSI	1105		256/257
06800	Female thread 1/2" up to 1"	S/G/L d ₀ =12,5 S/G	-270°C - +225°C 3K - 498K	3,0 - 25,0 bar 43,5 - 362,6 PSI	1105		258/259
06805	Female thread 1/2" up to 1"	S/G/L d ₀ =12,5 S/G	-270°C - +225°C 3K - 498K	3,0 - 25,0 bar 43,5 - 362,6 PSI	1105		260/261
06810, 06815	Male thread 1/2" up to 3/4"	S/G/L	-270°C - +400°C 3K - 673K	0,5 - 180 bar 7,3 - 2610,7 PSI	1130		262-266
06850, 06855	Male thread 1/2" up to 1-1/2"	S/G/L	-270°C - +400°C 3K - 673K	0,2 - 250 bar 2,9 - 3626 PSI	1130		267-272
55335	Female thread 3/8" up to 1"	-	-270°C - +225°C 3K - 498K	-	-		273

Overflow Valves

Type	Inlet	Medium	Temperature	Set pressure range	Approval		Page
					TÜV-SV	ASME	
06386	Male thread 1/2" up to 3/4"	S/G	-196°C - +185°C 77K - 458K	0,5 - 35,0 bar 7,3 - 507,6 PSI	-		274/275
06381	Male thread 1/2" up to 3/4"	S/G/L	-196°C - +185°C 77K - 458K	0,5 - 35,0 bar 7,3 - 507,6 PSI	-		276/277

Storage and Transportation of Cryogenic Gases

Content



Changeover Valves

Type	Nominal size	Inlet	Outlet	Temperature	Working pressure	Page
06510	DN20	Female thread 1"	Female thread 1/2" up to 3/4"	-196°C - +120°C 77K - 393K	PN 50	278
06510	DN20	Union braze/weld fittings	Female thread 1/2" up to 3/4"	-196°C - +120°C 77K - 393K	PN 50	279
06510	DN32	Female thread 1-1/2"	Female thread 1" up to 1-1/2"	-196°C - +120°C 77K - 393K	PN 50	280
06512	DN20	Female thread 1"	Female thread 1/2" up to 3/4"	-196°C - +120°C 77K - 393K	PN 50	281
06520	DN20	Female thread 1"	Female thread 1/2" up to 3/4"	-196°C - +120°C 77K - 393K	PN 50	282
06530	DN20	Female thread 1"	Female thread 1/2" up to 3/4"	-196°C - +120°C 77K - 393K	PN 50	283
06405	DN15 DN25	Female thread 3/4" up to 1"	Female thread 1/2" up to 1"	-196°C - +185°C 77K - 458K	DN15: PN 40 DN25: PN 45	284
06401	DN15	Locking sleeve Female thread	Locking sleeve Female thread Flanged	-196°C - +185°C 77K - 458K	PN 125 (up to max. PN250)	285
06401	DN15	Flanged	Locking sleeve Female thread Flanged	-196°C - +185°C 77K - 458K	PN 160 (up to max. PN 250)	286
06401	DN25	Locking sleeve Female thread	Locking sleeve Female thread Flanged	-196°C - +185°C 77K - 458K	PN 125 (up to max. PN250)	287
06401	DN25	Flanged	Locking sleeve Female thread Flanged	-196°C - +185°C 77K - 458K	PN 160 (up to max. PN 250)	288
06401	DN15 DN25	Locking sleeve, Female thread, Flanged	Locking sleeve, Female thread, Flanged	-196°C - +185°C 77K - 458K	PN 63 (up to max. PN 100)	289
06900	1/2"	Male thread	-	-196°C - +120°C 77K - 393K	-	290
06901	1/2"	Male thread	-	-196°C - +120°C 77K - 393K	-	291

Fire Safe Valves

Type	Nominal size	Connections	Working pressure	Temperature	Page
01651	DN10 - DN100	Butt weld connection, Socket weld connection	PN50 (DN100=PN40)	-196°C - +120°C 77K - 393K	294
01655	DN10 - DN50	Thread type G (BSPP) Thread type R (BSPT) Thread type NPT	PN50	-196°C - +120°C 77K - 393K	295
03651	DN25 - DN100	Flanged DIN EN PN40	PN40	-196°C - +120°C 77K - 393K	296
03651	DN25 - DN100	Flanged ANSI class 300	class 300	-196°C - +120°C 77K - 393K	297
01641	DN10 - DN150	Butt weld connection, Socket weld connection	PN50 (DN100/150=PN40)	-196°C - +120°C 77K - 393K	298
01641	DN200	Butt weld connection, Socket weld connection	PN25	-196°C - +120°C 77K - 393K	299
01645	DN10 - DN50	Thread type G (BSPP) Thread type R (BSPT) Thread type NPT	PN50	-196°C - +120°C 77K - 393K	300
03641	DN25 - DN100	Flanged DIN EN PN40	PN40	-196°C - +120°C 77K - 393K	301
03641	DN25 - DN100	Flanged ANSI class 300	class 300	-196°C - +120°C 77K - 393K	302
01262	DN10 - DN50	Butt weld connection, Socket weld connection	PN50	-196°C - +120°C 77K - 393K	303
01642	DN15 - DN50	Butt weld connection, Socket weld connection	PN50	-196°C - +120°C 77K - 393K	304
15090, 15091	DN8 - DN100	Socket weld connection, Butt weld connection	PN25 - PN100	-200°C - +200°C 73K - 473K	305
15092, 15093	DN8 - DN100	Thread type NPT, Thread type G	PN25 - PN100	-200°C - +200°C 73K - 473K	306
01643	DN10 - DN150	Butt weld connection, Socket weld connection	PN50 (DN100/150=PN40)	-196°C - +120°C 77K - 393K	307
01653	DN15 - DN80	Butt weld connection, Socket weld connection	PN50	-196°C - +120°C 77K - 393K	308
05614	DN10 - DN150	Butt weld connection, Socket weld connection	PN50 (DN100/150=PN40)	-196°C - +120°C 77K - 393K	309

Offshore Valves

Type	Nominal size	Connections	Working pressure	Temperature	Page
01751	DN10 - DN100	Butt weld connection, Socket weld connection	PN50 (DN100=PN40)	-255°C - +120°C 18K - 393K	310
01755	DN10 - DN50	Thread type G (BSPP) Thread type R (BSPT) Thread type NPT	PN50	-255°C - +120°C 18K - 393K	311
01741	DN10 - DN150	Butt weld connection, Socket weld connection	PN50 (DN100=PN40)	-255°C - +120°C 18K - 393K	312
01741	DN200	Butt weld connection, Socket weld connection	PN25	-255°C - +120°C 18K - 393K	313
01745	DN10 - DN50	Thread type G (BSPP) Thread type R (BSPT) Thread type NPT	PN50	-255°C - +120°C 18K - 393K	314
01272	DN10 - DN50	Butt weld connection, Socket weld connection	PN50	-255°C - +120°C 18K - 393K	315

Offshore Valves

Type	Nominal size	Connections	Working pressure	Temperature	Page
01743	DN10 - DN150	Butt weld connection, Socket weld connection	PN50 (DN100/150=PN40)	-255°C - +120°C 18K - 393K	316
01753	DN15 - DN80	Butt weld connection, Socket weld connection	PN50	-255°C - +120°C 18K - 393K	317
27521	DN10 - DN100	Pneumatic actuator for globe valves, spring to close	-	-40°C - +80°C 233K - 353K	318
27521	DN10 - DN100	Pneumatic actuator for control valves, spring to close	-	-40°C - +80°C 233K - 353K	319
27522	DN10 - DN100	Pneumatic actuator for globe valves, spring to open	-	-40°C - +80°C 233K - 353K	320
27522	DN10 - DN100	Pneumatic actuator for control valves, spring to open	-	-40°C - +80°C 233K - 353K	321
05714	DN10 - DN150	Butt weld connection, Socket weld connection	PN50 (DN100/150=PN40)	-255°C - +120°C 18K - 393K	322
05717	DN10 - DN50	Thread type G (BSPP) Thread type R (BSPT) Thread type NPT	PN50	-255°C - +120°C 18K - 393K	323
05719	DN25 - DN100	Flanged DIN EN PN40	PN40	-255°C - +120°C 18K - 393K	324
05719	DN25 - DN100	Flanged ANSI class 300	class 300	-255°C - +120°C 18K - 393K	325
08717	DN10 - DN100	Butt weld connection, Socket weld connection	PN50 (DN100=PN40)	-255°C - +120°C 18K - 393K	326
08716	DN10 - DN50	Thread type G (BSPP) Thread type R (BSPT) Thread type NPT	PN50	-255°C - +120°C 18K - 393K	327



Fire Safe and Offshore Valves

Type	Nominal size	Connections	Working pressure	Temperature	Page
01851	DN10 - DN100	Butt weld connection, Socket weld connection	PN50 (DN100=PN40)	-255°C - +120°C 18K - 393K	328
01855	DN10 - DN50	Thread type G (BSPP) Thread type R (BSPT) Thread type NPT	PN50	-255°C - +120°C 18K - 393K	329
03851	DN25 - DN100	Flanged DIN EN PN40	PN40	-255°C - +120°C 18K - 393K	330
03851	DN25 - DN100	Flanged ANSI class 300	class 300	-255°C - +120°C 18K - 393K	331
01841	DN10 - DN150	Butt weld connection, Socket weld connection	PN50 (DN100=PN40)	-255°C - +120°C 18K - 393K	332
01841	DN200	Butt weld connection, Socket weld connection	PN25	-196°C - +120°C 77K - 393K	333
01841	DN10 - DN100	Butt weld connection, Socket weld connection	PN63	-255°C - +120°C 18K - 393K	334
01845	DN10 - DN50	Thread type G (BSPP) Thread type R (BSPT) Thread type NPT	PN50	-255°C - +120°C 18K - 393K	335
03841	DN25 - DN100	Flanged DIN EN PN40	PN40	-255°C - +120°C 18K - 393K	336
03841	DN25 - DN100	Flanged ANSI class 300	class 300	-255°C - +120°C 18K - 393K	337
01282	DN10 - DN50	Butt weld connection, Socket weld connection	PN50	-255°C - +120°C 18K - 393K	338
01843	DN10 - DN150	Butt weld connection, Socket weld connection	PN50 (DN100/150=PN40)	-255°C - +120°C 18K - 393K	339
01853	DN15 - DN80	Butt weld connection, Socket weld connection	PN50	-255°C - +120°C 18K - 393K	340

Spare Parts Firesafe and Offshore Applications

Type	Specification	Nominal size	Suitable for Valve type	Page
28651	Topwork, stainless steel	DN10 - DN150	01651, 01655, 03651	341
28641	Topwork, stainless steel	DN10 - DN150	01641, 01645, 03641	342
28751	Topwork, stainless steel	DN10 - DN150	01751, 01755, 03751	343
28741	Topwork, stainless steel	DN10 - DN150	01741, 01745, 03741	344
28851	Topwork, stainless steel	DN10 - DN150	01851, 01855, 03851	345
28841	Topwork, stainless steel	DN10 - DN150	01841, 01845, 03841	346
28203	Disc complete, stainless steel	DN10 - DN100	01741, 01745, 01751, 01755	347
29203	Disc complete, stainless steel	DN10 - DN150	01641, 01645, 01651, 01655, 03641, 03651	347
29203	Disc complete, stainless steel	DN10 - DN150	01841, 01845, 01851, 01855, 03841, 03851	347
29205	Check disc complete, stainless steel	DN10 - DN150	01641, 01645, 01651, 01655, 03641, 03651	348
29205	Check disc complete, stainless steel	DN10 - DN150	01841, 01845, 01851, 01855, 03841, 03851	348
28205	Check disc complete, stainless steel	DN10 - DN150	01741, 01745, 01751, 01755, 03741, 03751	348
28206	Check disc complete, stainless steel	DN10 - DN100	05714, 05717, 05719	349
29206	Check disc complete, stainless steel	DN10 - DN100	05614	349
30641	Sealing spare part kit	DN10 - DN150	01641, 01645, 01651, 01655, 01841, 01845, 01851, 01855, 03641, 03651	350
30741	Sealing spare part kit	DN10 - DN150	01741, 01745, 01751, 01755, 03741, 03751	351
30714	Sealing spare part kit	DN10 - DN100	05714, 05717, 05719	352

Storage and Transportation of Cryogenic Gases



Transport and storage: The gas mixing plant in Easington on the east coast of the UK ensures for proper gas composition with the help of nitrogen. Equipped with HEROSE valves for cryogenic service.

Globe Valves

Type 01301 - Globe Valve



Cryogenic-Globe and Globe/Check Valves, PN50

Bronze body and topwork
 "live loaded" gland packing
 "cleaned and degreased for oxygen service"

Part No. 01301.X.0001

Part No. 01301.X.5001 Globe/Check Valve

Socket end for copper pipes acc. to DIN EN 12449 or ASTM B88

Available options - on request only:

- Socket end for stainless steel pipes acc. to ISO 1127
- Valve with control disc (tapered design)

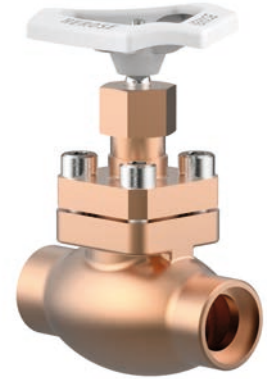

Applications:

Approved for air gases, vapours and cryogenic liquified gases incl. LNG.

Working temperature: -196°C / -321°F (77K) up to +120°C / +248°F (393K)

Recommended working temperature: -60°C / -76°F (213K) up to +120°C / +248°F (393K)

Materials	DIN EN	ASTM
1 Body	CC491K	B 62 UNS C83600
2 Valve seal	PTFE / Carbon filled (25%)	
3 Disc	CW614N	B 283 UNS C38500
4 Bonnet gasket	PTFE	
5 Headpiece	CC493K	B 505 UNS C93200
6 Bolts	1.4301/A2 A 194 B8	
8 Stem	1.4301	A 276 Grade 304
9 Gland packing	Graphite / PTFE	
10 Gland nut	CW614N	B 283 UNS C38500
11 Handwheel	Aluminium alloy	
12 Spring	CW452K	B 159 UNS C51900

Standard marking acc. to Pressure Equipment Directive 97/23/EC (PED).

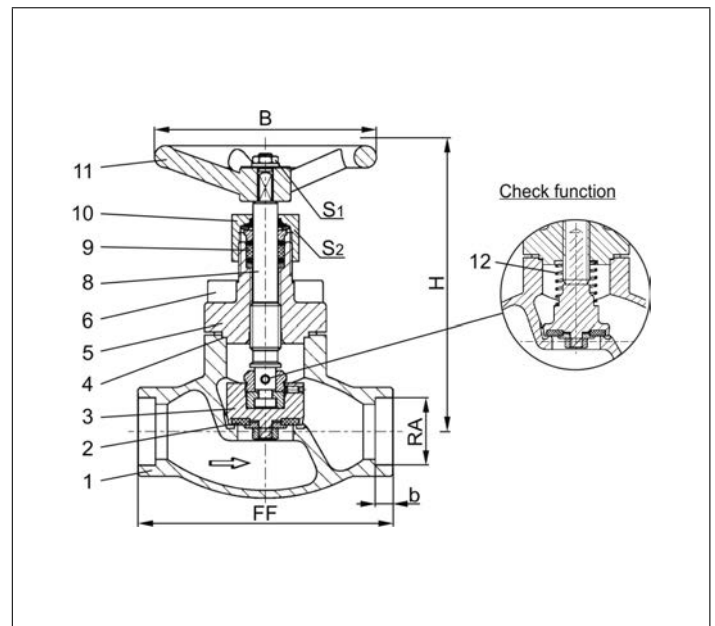

Type 01301 - Standard design	Technical data							
Nominal size	DN	10	15	20	25	32	40	50
Dimension code	.X.	X=DNRA, Example: valve DN10 for copper pipe RA _ø 12mm, X=1012						
Face-to-face dimension	FF	60	85	85	115	115	140	160
Height	H	140	140	140	140	170	175	200
Outside pipe-Ø	RA	dependent on order						
Socket depth	b	6	6	8	8	10	13	20
Handwheel-Ø	B	100	100	100	100	125	125	125
Wrench size across flats	S ₁	10	10	10	10	13	13	13
Wrench size across flats	S ₂	30	30	30	30	36	36	36
Weight	ca. kg	1.0	1.3	1.7	2.0	2.8	4.2	6.7
Kvs-Value	m ³ /h	1.6	4.3	6.7	11.5	12.1	22.6	37.1
Cv-Value	gal/min	1.9	5.0	7.8	13.4	14.1	26.3	43.2

Dimensions in mm.

Globe Valves

Type 01301 - Globe Valve



Cryogenic-Globe and Globe/Check Valves, PN50

- Bronze body and topwork
- "live loaded" gland packing
- "cleaned and degreased for oxygen service"

Part No. 01301.X.0008

Part No. 01301.X.5008 Globe/Check Valve

Complete with brazed copper stubs acc. to DIN EN 12449

Available options - on request only:

- Valve with control disc (tapered design)



Applications:

Approved for air gases, vapours and cryogenic liquefied gases incl. LNG.

Working temperature: - 196°C / -321°F (77K) up to +120°C / +248°F (393K)

Recommended working temperature: -60°C / -76°F (213K) up to +120°C / +248°F (393K)

Materials	DIN EN	ASTM
1 Body	CC491K	B 62 UNS C83600
2 Valve seal	PTFE / Carbon filled (25%)	
3 Disc	CW614N	B 283 UNS C38500
4 Bonnet gasket	PTFE	
5 Headpiece	CC493K	B 505 UNS C93200
6 Bolts	1.4301/A2	A 194 B8
8 Stem	1.4301	A 276 Grade 304
9 Gland packing	Graphite / PTFE	
10 Gland nut	CW614N	B 283 UNS C38500
11 Handwheel	Aluminium alloy	
12 Spring	CW452K	B 159 UNS C51900
13 Copper stubs	CW024A	B 152 UNS C12200

Standard marking acc. to Pressure Equipment Directive 97/23/EC (PED).

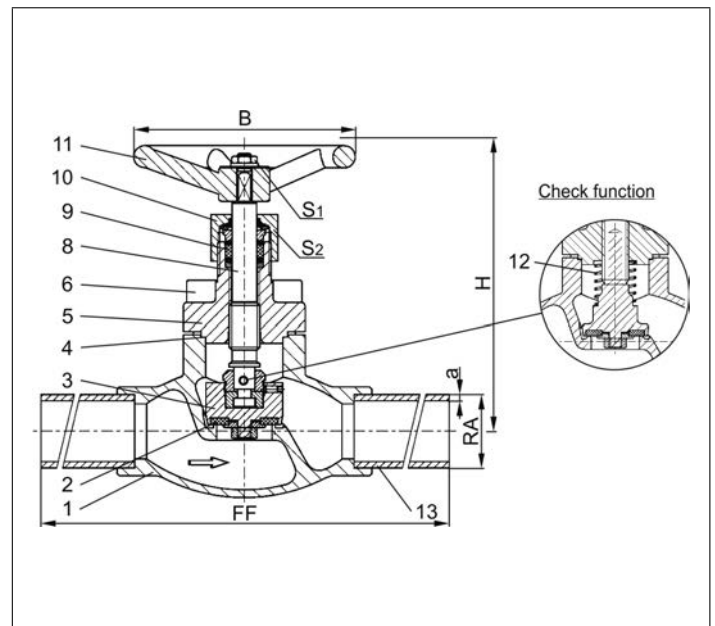

Type 01301 - Standard design	Technical data								
Nominal size	DN	10	15	15	20	25	32	40	50
Dimension code	.X.	1012	1515	1518	2022	2528	3235	4042	5054
Face-to-face dimension	FF	360	385	385	385	415	415	420	460
Height	H	140	140	140	140	140	170	175	200
Outside pipe-Ø	RA	12.0	15.0	18.0	22.0	28.0	35.0	42.0	54.0
Wall thickness pipe	a	1.0	1.5	1.5	1.5	1.5	1.5	1.5	2.0
Handwheel-Ø	B	100	100	100	100	100	125	125	125
Wrench size across flats	S ₁	10	10	10	10	10	13	13	13
Wrench size across flats	S ₂	30	30	30	30	30	36	36	36
Weight	ca. kg	1.1	1.4	1.4	1.8	2.4	3.2	4.8	7.5
Kvs-Value	m ³ /h	2.2	4.3	4.3	6.7	11.5	12.1	22.6	37.1
Cv-Value	gal/min	2.6	5.0	5.0	7.8	13.4	14.1	26.3	43.2

Dimensions in mm.

Globe Valves

Type 01301 - Globe Valve



Cryogenic-Globe and Globe/Check Valves, PN50

Bronze body and topwork
 "live loaded" gland packing
 "cleaned and degreased for oxygen service"

Part No. 01301.X.0007

Part No. 01301.X.5007 Globe/Check Valve

Complete with brazed stainless steel stubs acc. to DIN EN 10216-5 or ASTM A312

Available options - on request only:

- Valve with control disc (tapered design)

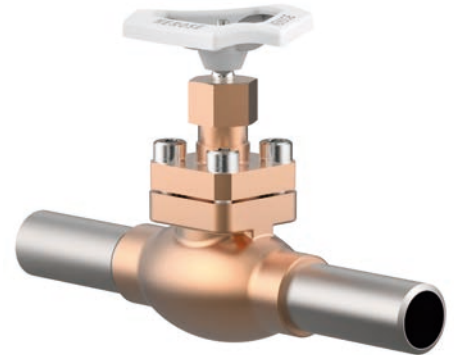

Applications:

Approved for air gases, vapours and cryogenic liquefied gases incl. LNG.

Working temperature: -196°C / -321°F (77K) up to +120°C / +248°F (393K)

Recommended working temperature: -60°C / -76°F (213K) up to +120°C / +248°F (393K)

Materials	DIN EN	ASTM
1 Body	CC491K	B 62 UNS C83600
2 Valve seal	PTFE / Carbon filled (25%)	
3 Disc	CW614N	B 283 UNS C38500
4 Bonnet gasket	PTFE	
5 Headpiece	CC493K	B 505 UNS C93200
6 Bolts	1.4301/A2	A 194 B8
8 Stem	1.4301	A 276 Grade 304
9 Gland packing	Graphite / PTFE	
10 Gland nut	CW614N	B 283 UNS C38500
11 Handwheel	Aluminium alloy	
12 Spring	CW452K	B 159 UNS C51900
13 Stainless steel stubs	1.4306	A 312 TP304L

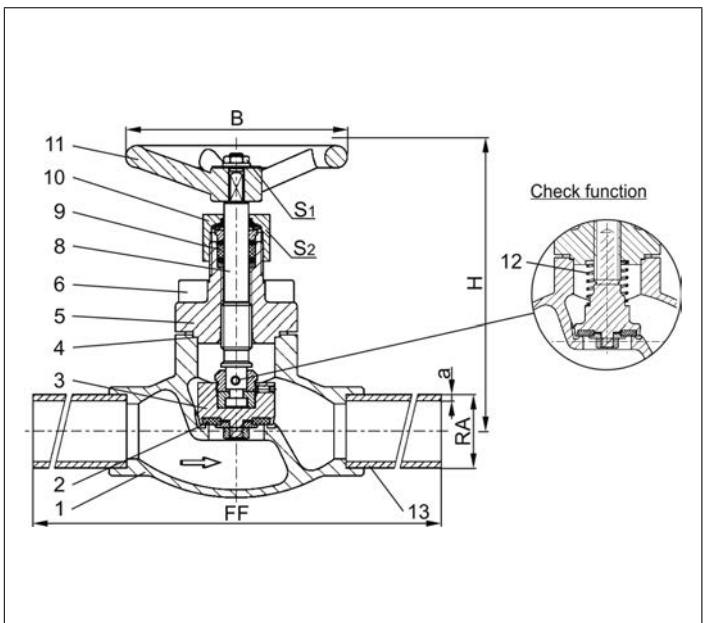

Standard marking acc. to Pressure Equipment Directive 97/23/EC (PED).



Type 01301 - Standard design	Technical data								
Nominal size	DN	10	10	15	20	25	32	40	50
Dimension code	.X.	1012	1017	1521	2027	2533	3242	4048	5060
Face-to-face dimension	FF	210	210	235	235	265	265	290	310
Height	H	140	140	140	140	140	170	175	200
Outside pipe-Ø ISO 1127	RA	12.0	17.2	21.3	26.9	33.7	42.4	48.3	60.3
Wall thickness pipe ISO 1127	a	1.0	2.3	2.6	2.9	3.2	3.2	3.6	3.6
Outside pipe-Ø ASTM A312	RA	-	17.15	21.34	26.67	33.4	42.16	48.26	60.33
Wall thickness pipe ASTM A312	a	dimensions acc. to S10 or S40							
Handwheel-Ø	B	100	100	100	100	100	125	125	125
Wrench size across flats	S ₁	10	10	10	10	10	13	13	13
Wrench size across flats	S ₂	30	30	30	30	30	36	36	36
Weight	ca. kg	1.05	1.15	1.5	1.8	2.4	3.2	4.8	7.5
Kvs-Value	m ³ /h	2.2	2.2	4.3	6.7	11.5	12.1	22.6	37.1
Cv-Value	gal/min	2.6	2.6	5.0	7.8	13.4	14.1	26.3	43.2

Dimensions in mm.

Globe Valves

Type 01305 - Globe Valve



Cryogenic-Globe and Globe/Check Valves, PN50

- Bronze body and topwork
- "live loaded" gland packing
- "cleaned and degreased for oxygen service"

Part No. 01305.X.0001

Part No. 01305.X.5001 Globe/Check Valve

Female thread connection (G) acc. to ISO 228/1

Part No. 01305.X.0006

Part No. 01305.X.5006 Globe/Check Valve

Female thread connection NPT acc. to ANSI B 1.20.1

Available options - on request only:

- Female thread connection (R) acc. to ISO 7-Rc
- Valve with control disc (tapered design)



Applications:

Approved for air gases, vapours and cryogenic liquefied gases incl. LNG.

Working temperature: -196°C / -321°F (77K) up to +120°C / +248°F (393K)

Recommended working temperature: -60°C / -76°F (213K) up to +120°C / +248°F (393K)

Materials	DIN EN	ASTM
1 Body	CC491K	B 62 UNS C83600
2 Valve seal	PTFE / Carbon filled (25%)	
3 Disc	CW614N	B 283 UNS C38500
4 Bonnet gasket	PTFE	
5 Headpiece	CC493K	B 505 UNS C93200
6 Bolts	1.4301/A2	A 194 B8
8 Stem	1.4301	A 276 Grade 304
9 Gland packing	Graphite / PTFE	
10 Gland nut	CW614N	B 283 UNS C38500
11 Handwheel	Aluminium alloy	
12 Spring	CW452K	B 159 UNS C51900

Standard marking acc. to Pressure Equipment Directive 97/23/EC (PED).

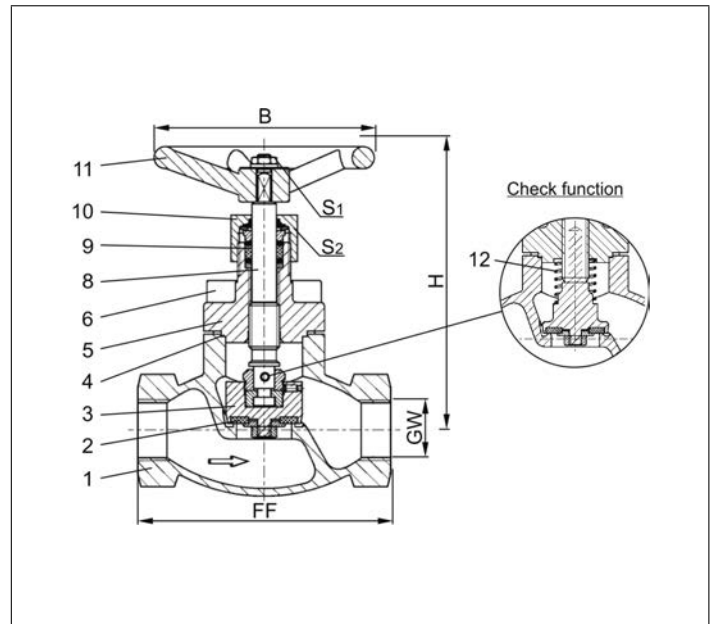

Type 01305 - Standard design	Technical data								
Nominal size	DN	10	10	15	20	25	32	40	50
Thread size	GW	1/4	3/8	1/2	3/4	1	1-1/4	1-1/2	2
Dimension code	.X.	0200	0300	0400	0600	1000	1200	1400	2000
Face-to-face dimension	FF	60	60	85	85	115	115	140	160
Height	H	140	140	140	140	140	170	175	200
Handwheel-Ø	B	100	100	100	100	100	125	125	125
Wrench size across flats	S ₁	10	10	10	10	10	13	13	13
Wrench size across flats	S ₂	30	30	30	30	30	36	36	36
Weight	ca. kg	1.0	1.0	1.3	1.7	2.0	2.8	4.2	6.7
Kvs-Value	m ³ /h	1.6	2.2	4.3	6.7	11.5	20.6	22.6	37.1
Cv-Value	gal/min	1.9	2.6	5.0	7.8	13.4	23.9	26.3	43.2

Dimensions in mm.

Globe Valves

Type 02401 - Globe Valve



Cryogenic-Globe and Globe/Check Valves, PN50

Bronze body and topwork,
 "live loaded" gland packing
 "cleaned and degreased for oxygen service"

Part No. 02401.X.0001

Part No. 02401.X.5001 Globe/Check Valve

Male thread for union connection

Available options - on request only:

- Valve with control disc (tapered design)



Applications:

Approved for air gases, vapours and cryogenic liquefied gases incl. LNG.

Working temperature: -196°C / -321°F (77K) up to +120°C / +248°F (393K)

Recommended working temperature: -60°C / -76°F (213K) up to +120°C / +248°F (393K)

Materials	DIN EN	ASTM
1 Body	CC491K	B 62 UNS C83600
2 Valve seal	PTFE / Carbon filled (25%)	
3 Disc	CW614N	B 283 UNS C38500
4 Bonnet gasket	PTFE	
5 Headpiece	CC493K	B 505 UNS C93200
6 Bolts	1.4301/A2 A 194 B8	
8 Stem	1.4301	A 276 Grade 304
9 Gland packing	Graphite / PTFE	
10 Gland nut	CW614N	B 283 UNS C38500
11 Handwheel	Aluminium alloy	
12 Spring	CW452K	B 159 UNS C51900

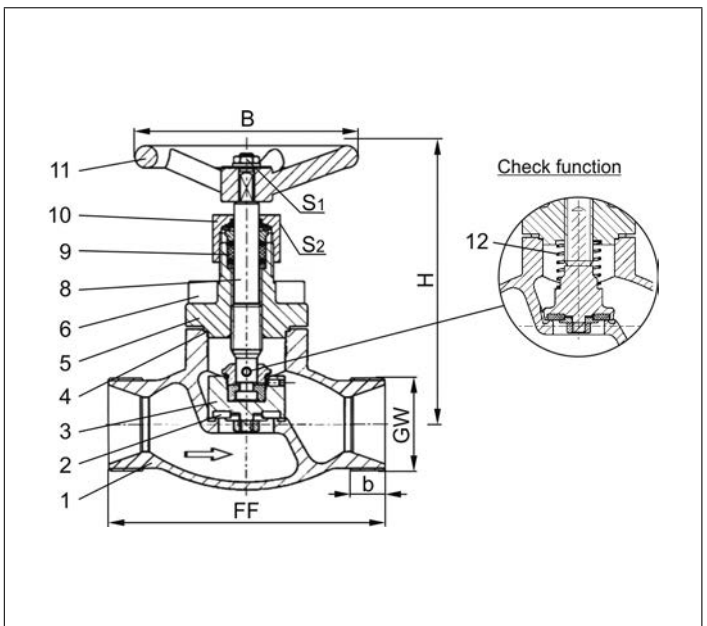

Standard marking acc. to Pressure Equipment Directive 97/23/EC (PED).



Type 02401 - Standard design	Technical data					
	DN	10	20	32	40	50
Nominal size	DN	10	20	32	40	50
Dimension code	.X.	0100	0200	0320	0400	0500
Face-to-face dimension	FF	60	85	115	140	160
Height	H	140	140	170	175	200
Union thread	GW	M26x1.5	M40x2.0	M55x2.0	M65x2.0	M78x2.0
Thread length	b	10	11	14	17	20
Handwheel-Ø	B	100	100	125	125	125
Wrench size across flats	S ₁	10	10	13	13	13
Wrench size across flats	S ₂	30	30	36	36	36
Weight	ca. kg	1.0	1.7	2.8	4.2	6.7
Kvs-Value	m ³ /h	2.2	6.7	12.1	22.6	37.1
Cv-Value	gal/min	2.6	7.8	14.1	26.3	43.2

Dimensions in mm.

Globe Valves

Type 02401 - Globe Valve



Cryogenic-Globe and Globe/Check Valves, PN50

Bronze body and topwork,
 "live loaded" gland packing
 "cleaned and degreased for oxygen service"

Part No. 02401.X.0008

Part No. 02401.X.5008 Globe/Check Valve

Completed with union type braze fittings for copper pipes acc. to DIN EN 12449 or ASTM B88

Available options - on request only:

- Valve with control disc (tapered design)



Applications:

Approved for air gases, vapours and cryogenic liquefied gases incl. LNG.

Working temperature: -196°C / -321°F (77K) up to +120°C / +248°F (393K)

Recommended working temperature: -60°C / -76°F (213K) up to +120°C / +248°F (393K)

Materials	DIN EN	ASTM
1 Body	CC491K	B 62 UNS C83600
2 Valve seal	PTFE / Carbon filled (25%)	
3 Disc	CW614N	B 283 UNS C38500
4 Bonnet gasket	PTFE	
5 Headpiece	CC493K	B 505 UNS C93200
6 Bolts	1.4301/A2 A 194 B8	
8 Stem	1.4301	A 276 Grade 304
9 Gland packing	Graphite / PTFE	
10 Gland nut	CW614N	B 283 UNS C38500
11 Handwheel	Aluminium alloy	
12 Spring	CW452K	B 159 UNS C51900
13 Braze fitting	CC493K	B 505 UNS C93200
14 Union nut	CC493K	B 505 UNS C93200

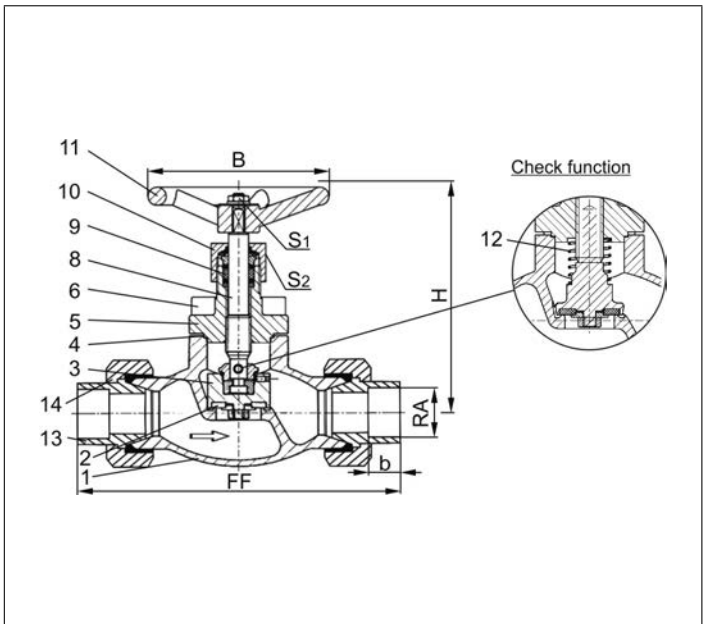

Standard marking acc. to Pressure Equipment Directive 97/23/EC (PED).



Type 02401 - Standard design	Technical data								
Nominal size	DN	10	10	20	20	32	32	40	50
Dimension code	.X.	1012	1015	1518	2022	2528	3235	4042	5054
Face-to-face dimension	FF	98	98	132	132	171	171	230	230
Height	H	140	140	140	140	170	170	175	200
Outside pipe-Ø	RA	12.0	15.0	18.0	22.0	28.0	35.0	42.0	54.0
Socket depth	b	11	11	14	14	17	17	17	17
Handwheel-Ø	B	100	100	100	100	125	125	125	125
Wrench size across flats	S ₁	10	10	10	10	13	13	13	13
Wrench size across flats	S ₂	30	30	30	30	36	36	36	36
Weight	ca. kg	1.2	1.2	2.4	2.4	4.0	4.0	6.3	9.5
Kvs-Value	m ³ /h	1.6	2.2	6.0	6.7	11.5	12.1	22.6	37.1
Cv-Value	gal/min	1.9	2.6	7.1	7.8	13.4	14.1	26.3	43.2

Dimensions in mm.

Globe Valves

Type 02401 - Globe Valve



Cryogenic-Globe and Globe/Check Valves, PN50

Bronze body and topwork,
 "live loaded" gland packing
 "cleaned and degreased for oxygen service"

Part No. 02401.X.0007

Part No. 02401.X.5007 Globe/Check Valve

Completed with union type butt weld fittings for stainless steel pipes
 acc. to ISO 1127 or ASTM A312

Available options - on request only:

- Valve with control disc (tapered design)

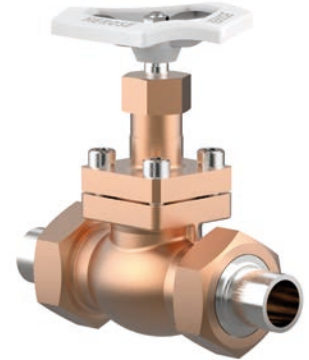

Applications:

Approved for air gases, vapours and cryogenic liquefied gases incl. LNG.

Working temperature: -196°C / -321°F (77K) up to +120°C / +248°F (393K)

Recommended working temperature: -60°C / -76°F (213K) up to +120°C / +248°F (393K)

Materials	DIN EN	ASTM
1 Body	CC491K	B 62 UNS C83600
2 Valve seal	PTFE / Carbon filled (25%)	
3 Disc	CW614N	B 283 UNS C38500
4 Bonnet gasket	PTFE	
5 Headpiece	CC493K	B 505 UNS C93200
6 Bolts	1.4301/A2 A 194 B8	
8 Stem	1.4301	A 276 Grade 304
9 Gland packing	Graphite / PTFE	
10 Gland nut	CW614N	B 283 UNS C38500
11 Handwheel	Aluminium alloy	
12 Spring	CW452K	B 159 UNS C51900
13 Weld fitting	1.4301	A 276 Grade 304
14 Union nut	CC493K	B 505 UNS C93200

Standard marking acc. to Pressure Equipment
 Directive 97/23/EC (PED).

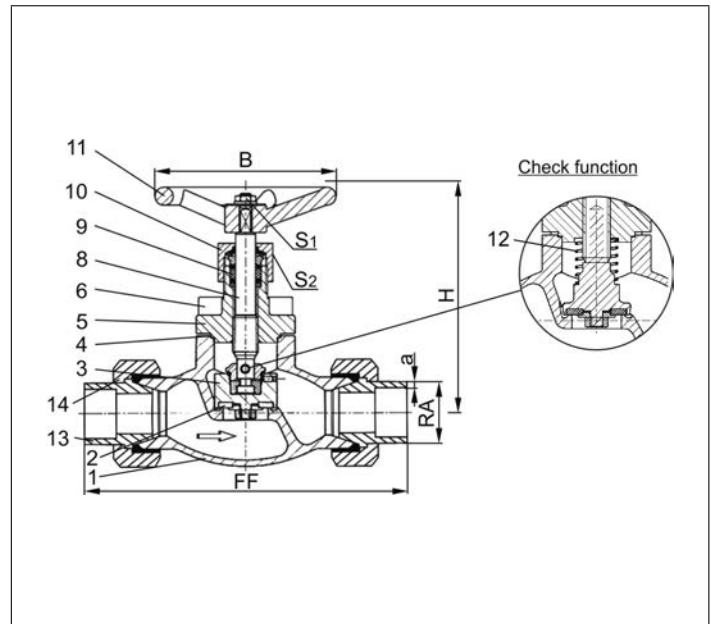

Type 02401 - Standard design	Technical data									
Nominal size	DN	10	10	20	20	32	32	40	50	
Dimension code	.X.	1012	1017	1521	2027	2533	3242	4048	5060	
Face-to-face dimension	FF	137	141	168	168	203	203	230	263	
Height	H	140	140	140	140	170	170	175	200	
Outside pipe-Ø ISO 1127	RA	12.0	17.2	21.3	26.9	33.7	42.4	48.3	60.3	
Wall thickness pipe ISO 1127	a	1.0	2.3	2.6	2.0	3.2	2.0	3.6	3.6	
Outside pipe-Ø ASTM A312	RA	-	17.15	21.34	26.67	33.40	42.16	48.26	60.33	
Wall thickness pipe ASTM A312	a	dimensions acc. to S10 or S40								
Handwheel-Ø	B	100	100	100	100	125	125	125	125	
Wrench size across flats	S ₁	10	10	10	10	13	13	13	13	
Wrench size across flats	S ₂	30	30	30	30	36	36	36	36	
Weight	ca. kg	1.2	1.2	2.4	2.4	4.0	4.0	6.3	9.5	
Kvs-Value	m ³ /h	1.6	2.2	6.7	6.7	12.1	12.1	22.6	37.1	
Cv-Value	gal/min	1.9	2.6	7.8	7.8	14.1	14.1	26.3	43.2	

Dimensions in mm.

Globe Valves

Type 01331 - Globe Valve



Cryogenic-Globe and Globe/Check Valves, PN50 (DN100/150=PN40)

- Stainless steel body and bronze topwork
- "live loaded" gland packing
- "cleaned and degreased for oxygen service"

Part No. 01331.X.000*

Part No. 01331.X.500* Globe/Check Valve

*Butt weld connection for stainless steel pipes acc. to ISO 1127 or ASTM A312

Part No. 01331.X.0004

Part No. 01331.X.5004 Globe/Check Valve

Socket weld connection for stainless steel pipes acc. to ISO 1127 or ASTM A312

Available options - on request only:

- Welded stainless steel stubs acc. to ISO 1127 or ASTM A312 - length FF + 200mm
- Valve with control disc (tapered design)



Applications:

Approved for air gases, vapours and cryogenic liquefied gases incl. LNG.

Working temperature: -196°C / -321°F (77K) up to +120°C / +248°F (393K)

Recommended working temperature: -60°C / -76°F (213K) up to +120°C / +248°F (393K)

Materials	DIN EN	ASTM
1 Body	1.4308	A 351 CF8
2 Valve seal up to DN50	PTFE / Carbon filled (25%)	
2a Valve seal from DN65	PTFE	
3 Disc	CW614N	B 283 UNS C38500
4 Bonnet gasket	PTFE	
5 Headpiece	CC493K	B 505 UNS C93200
6 Bolts	1.4301/A2	A 194 B8
8 Stem	1.4301	A 276 Grade 304
9 Gland packing	Graphite / PTFE	
10 Gland nut	CW614N	B 283 UNS C38500
11 Handwheel	Aluminium alloy	
12 Spring	CW452K	B 159 UNS C51900

Standard marking acc. to Pressure Equipment Directive 97/23/EC (PED).

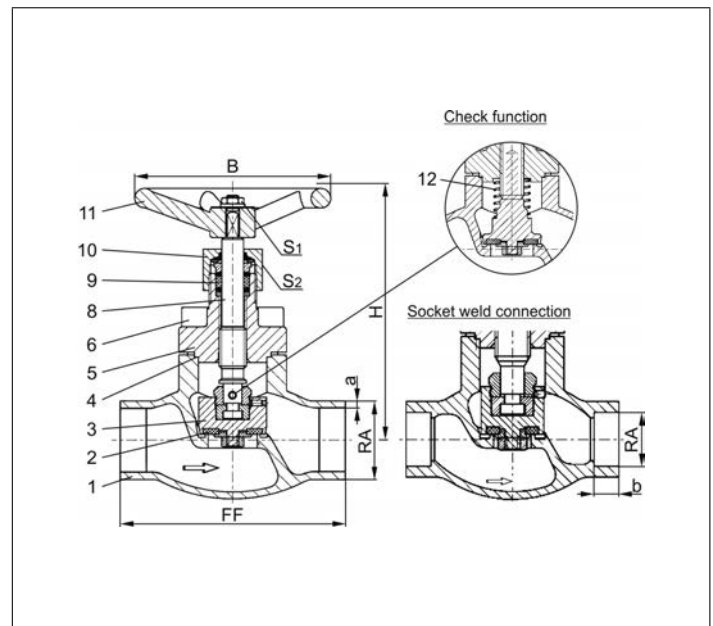

Type 01331 - Standard	Technical data														
Nominal size	DN	10	15	15	20	25	32	40	40	50	65	80	100	150	
Dimension code	.X.	1012	1517	1521	2026	2533	3238	4042	4048	5060	657x	8088	0114	0168	
Face-to-face dimension	FF	70	85	85	100	115	115	130	130	155	205	245	280	400	
Height	H	140	140	140	140	140	170	175	175	200	260	310	350	420	
Outside pipe-Ø ISO 1127	RA	12.0	17.2	21.3	26.9	33.7	38.0	42.4	48.3	60.3	76.1	88.9	114.3	168.3	
Wall thickness pipe ISO 1127	a	1.0	1.6	2.0	2.0	2.0	2.0	2.0	2.0	2.0	2.6	3.2	6.0	7.1	
Outside pipe-Ø ASTM A312	RA	13.72	17.15	21.34	26.67	33.40	-	42.16	48.26	60.32	73.02	88.90	114.30	168.27	
Wall thickness pipe ASTM A312	a	dimensions acc. to S10 or S40													
Socket depth	b	6	10	10	13	13	-	13	13	16	16	16	20	20	
Handwheel-Ø	B	100	100	100	100	100	125	125	125	125	200	250	315	360	
Wrench size across flats	S ₁	10	10	10	10	10	13	13	13	13	13	13	13	18	
Wrench size across flats	S ₂	30	30	30	30	30	36	36	36	36	36	36	41	41	
Weight	ca. kg	1.0	1.25	1.3	1.7	2.0	2.8	4.2	4.2	6.7	10.7	16.0	22.0	54.1	
Kvs-Value	m ³ /h	1.6	3.8	4.3	6.7	11.5	14.0	20.6	22.6	37.1	71.1	104.0	170.0	350.0	
Cv-Value	gal/min	1.9	4.4	5.0	7.8	13.4	16.2	23.9	26.3	43.2	82.7	120.9	195.2	401.8	

Dimensions in mm.

Globe Valves

Type 01335 - Globe Valve



Cryogenic-Globe and Globe/Check Valves, PN50

Stainless steel body and bronze topwork,
 "live loaded" gland packing
 "cleaned and degreased for oxygen service"

Part No. 01335.X.0001

Part No. 01335.X.5001 Globe/Check Valve

Female thread connection (G) acc. to ISO 228/1

Part No. 01335.X.0006

Part No. 01335.X.5006 Globe/Check Valve

Female thread connection NPT acc. to ANSI B 1.20.1

Available options - on request only:

- Female thread connection (R) acc. to ISO 7-Rc
- Valve with control disc (tapered design)



Applications:

Approved for air gases, vapours and cryogenic liquefied gases incl. LNG.

Working temperature: -196°C / -321°F (77K) up to +120°C / +248°F (393K)

Recommended working temperature: -60°C / -76°F (213K) up to +120°C / +248°F (393K)

Materials	DIN EN	ASTM
1 Body	1.4308	A 351 CF8
2 Valve seal	PTFE / Carbon filled (25%)	
3 Disc	CW614N	B 283 UNS C38500
4 Bonnet gasket	PTFE	
5 Headpiece	CC493K	B 505 UNS C93200
6 Bolts	1.4301/A2	A 194 B8
8 Stem	1.4301	A 276 Grade 304
9 Gland packing	Graphite / PTFE	
10 Gland nut	CW614N	B 283 UNS C38500
11 Handwheel	Aluminium alloy	
12 Spring	CW452K	B 159 UNS C51900

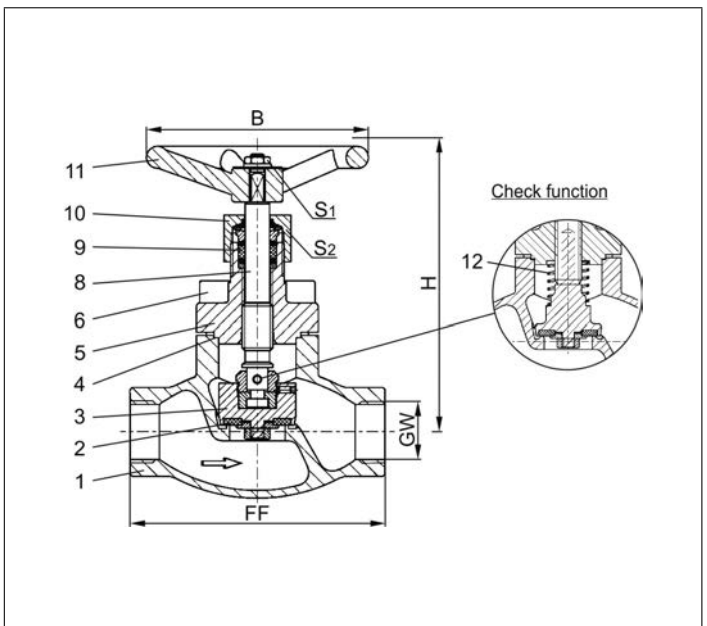

Standard marking acc. to Pressure Equipment Directive 97/23/EC (PED).



Type 01335 - Standard design	Technical data								
Nominal size	DN	10	10	15	20	25	40	40	50
Thread size	GW	1/4	3/8	1/2	3/4	1	1-1/4	1-1/2	2
Dimension code	.X.	0200	0300	0400	0600	1000	1200	1400	2000
Face-to-face dimension	FF	70	70	85	100	115	130	130	155
Height	H	140	140	140	140	140	175	175	200
Handwheel-Ø	B	100	100	100	100	100	125	125	125
Wrench size across flats	S ₁	10	10	10	10	10	13	13	13
Wrench size across flats	S ₂	30	30	30	30	30	36	36	36
Weight	ca. kg	1.0	1.0	1.3	1.7	2.0	4.2	4.2	6.7
Kvs-Value	m ³ /h	1.6	2.2	4.3	6.7	11.5	20.6	22.6	37.1
Cv-Value	gal/min	1.9	2.6	5.0	7.8	13.4	23.9	26.3	43.2

Dimensions in mm.

Globe Valves

Type 03331 - Globe Valve, DIN EN Flanges



Cryogenic-Globe and Globe/Check Valves, PN40

Stainless steel body and bronze topwork,
 "live loaded" gland packing
 "cleaned and degreased for oxygen service"

Part No. 03331.X.0002

Part No. 03331.X.5002 Globe/Check Valve

Flanged connection acc. to DIN EN 1092-1 PN40

Available options - on request only:

- Valve with control disc (tapered design)
- Nominal sizes DN15, DN20 and DN150 with welded flange

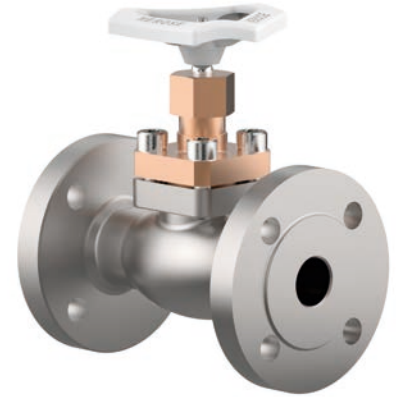

Applications:

Approved for air gases, vapours and cryogenic liquefied gases incl. LNG.

Working temperature: -196°C / -321°F (77K) up to +120°C / +248°F (393K)

Recommended working temperature: -60°C / -76°F (213K) up to +120°C / +248°F (393K)

Materials	DIN EN	ASTM
1 Body	1.4308	A 351 CF8
2 Valve seal up to DN50	PTFE / Carbon filled (25%)	
2a Valve seal from DN65	PTFE	
3 Disc	CW614N	B 283 UNS C38500
4 Bonnet gasket	PTFE	
5 Headpiece	CC493K	B 505 UNS C93200
6 Bolts	1.4301/A2	A 194 B8
8 Stem	1.4301	A 276 Grade 304
9 Gland packing	Graphite / PTFE	
10 Gland nut	CW614N	B 283 UNS C38500
11 Handwheel	Aluminium alloy	
12 Spring	CW452K	B 159 UNS C51900

Standard marking acc. to Pressure Equipment Directive 97/23/EC (PED).

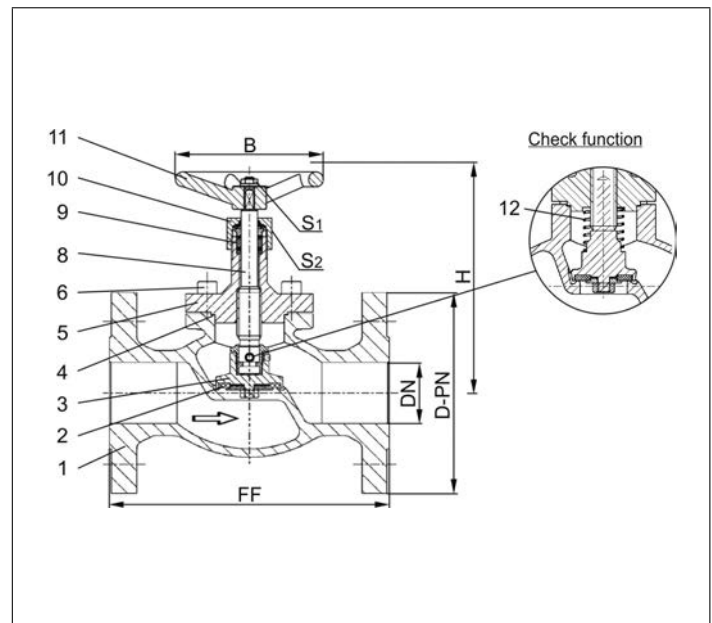

Type 03331 - Standard design	Technical data						
Nominal size	DN	25	40	50	65	80	100
Dimension code - Flange EN 1092-1 PN40	.X.	0250	0400	0500	0650	0800	1000
Flange-Ø	D-PN	115	150	165	185	200	235
Face-to-face dimension	FF	160	200	230	290	310	350
Height	H	140	175	200	260	310	350
Handwheel-Ø	B	100	125	125	200	250	315
Wrench size across flats	S ₁	10	13	13	13	13	13
Wrench size across flats	S ₂	30	36	36	36	36	41
Weight	ca. kg	4.5	9.1	12.9	20.6	27.6	39.8
Kvs-Value	m ³ /h	11.5	22.6	37.1	71.1	104.0	170.0
Cv-Value	gal/min	13.4	26.3	43.2	82.7	120.9	195.2

Dimensions in mm.

Globe Valves

Type 03331 - Globe Valve, ANSI Flanges



Cryogenic-Globe and Globe/Check Valves, class 300

Stainless steel body and bronze topwork,
 "live loaded" gland packing
 "cleaned and degreased for oxygen service"

Part No. 03331.X.0003

Part No. 03331.X.5003 Globe/Check Valve

Flanged connection acc. to ANSI B16.5 class 300

Available options - on request only:

- Valve with control disc (tapered design)
- Nominal sizes DN15, DN20 and DN150 with welded flange



Applications:

Approved for air gases, vapours and cryogenic liquefied gases incl. LNG.

Working temperature: -196°C / -321°F (77K) up to +120°C / +248°F (393K)

Recommended working temperature: -60°C / -76°F (213K) up to +120°C / +248°F (393K)

Materials	DIN EN	ASTM
1 Body	1.4308	A 351 CF8
2 Valve seal up to DN50	PTFE / Carbon filled (25%)	
2a Valve seal from DN65	PTFE	
3 Disc	CW614N	B 283 UNS C38500
4 Bonnet gasket	PTFE	
5 Headpiece	CC493K	B 505 UNS C93200
6 Bolts	1.4301/A2	A 194 B8
8 Stem	1.4301	A 276 Grade 304
9 Gland packing	Graphite / PTFE	
10 Gland nut	CW614N	B 283 UNS C38500
11 Handwheel	Aluminium alloy	
12 Spring	CW452K	B 159 UNS C51900

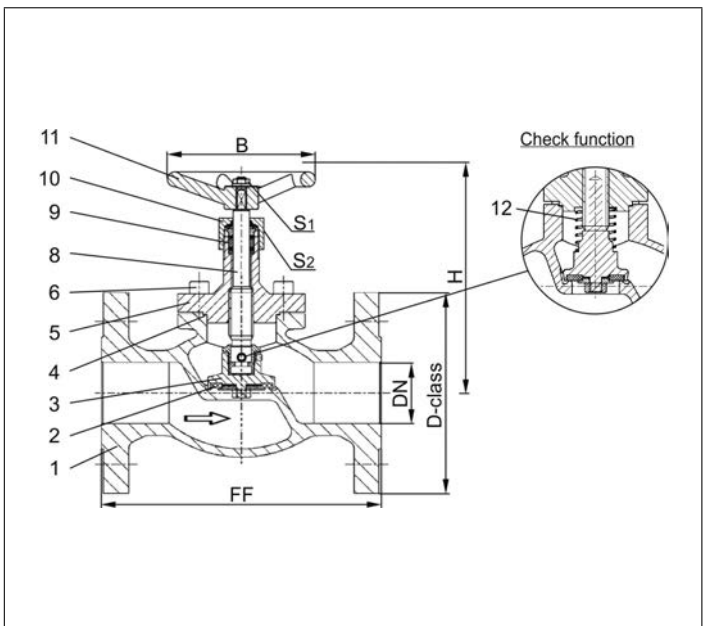

Standard marking acc. to Pressure Equipment Directive 97/23/EC (PED).



Type 03331 - Standard design	Technical data						
Nominal size	DN	25	40	50	65	80	100
Dimension code - Flange ANSI B16.5 class 300	.X.	1000	1400	2000	2400	3000	4000
Flange-Ø	D-class	123.9	155.4	165	190.5	209.5	254
Face-to-face dimension	FF	160	200	230	290	310	350
Height	H	140	175	200	260	310	350
Handwheel-Ø	B	100	125	125	200	250	315
Wrench size across flats	S ₁	10	13	13	13	13	13
Wrench size across flats	S ₂	30	36	36	36	36	41
Weight	ca. kg	4.5	9.1	12.9	20.6	27.6	39.8
Kvs-Value	m ³ /h	11.5	22.6	37.1	71.1	104.0	170.0
Cv-Value	gal/min	13.4	26.3	43.2	82.7	120.9	195.2

Dimensions in mm.

Globe Valves

Type 01351 - Globe Valve



Cryogenic-Globe and Globe/Check Valves, PN50 (DN100/150=PN40)

- Stainless steel body and topwork,
- "live loaded" gland packing
- "cleaned and degreased for oxygen service"

Part No. 01351.X.000*

Part No. 01351.X.500* Globe/Check Valve

*Butt weld connection for stainless steel pipes acc. to ISO 1127 or ASTM A312

Part No. 01351.X.0004

Part No. 01351.X.5004 Globe/Check Valve

Socket weld connection for stainless steel pipes acc. to ISO 1127 or ASTM A312

Available options - on request only:

- Welded stainless steel stubs acc. to ISO 1127 or ASTM A312 - length FF + 200mm
- Valve with control disc (tapered design)



Applications:

Approved for air gases, vapours and cryogenic liquefied gases incl. LNG.

Working temperature: -196°C / -321°F (77K) up to +120°C / +248°F (393K)

Recommended working temperature: -60°C / -76°F (213K) up to +120°C / +248°F (393K)

Materials	DIN EN	ASTM
1 Body	1.4308	A 351 CF8
2 Valve seal up to DN50	PTFE / Carbon filled (25%)	
2a Valve seal from DN65	PTFE	
3 Disc	1.4301	A 276 Grade 304
4 Bonnet gasket	PTFE	
5 Headpiece	1.4301 / 1.4308	A 276 Grade 304 / A 351 CF8
6 Bolts	1.4301/A2	A 194 B8
8 Stem	1.4301	A 276 Grade 304
9 Gland packing	Graphite / PTFE	
10 Gland nut	1.4305	A 276 Grade 303
11 Handwheel	Aluminium alloy	
12 Spring	1.4310	A 313 Grade 301
13 Bush	CW452K	B 159 UNS C51900

Standard marking acc. to Pressure Equipment Directive 97/23/EC (PED).

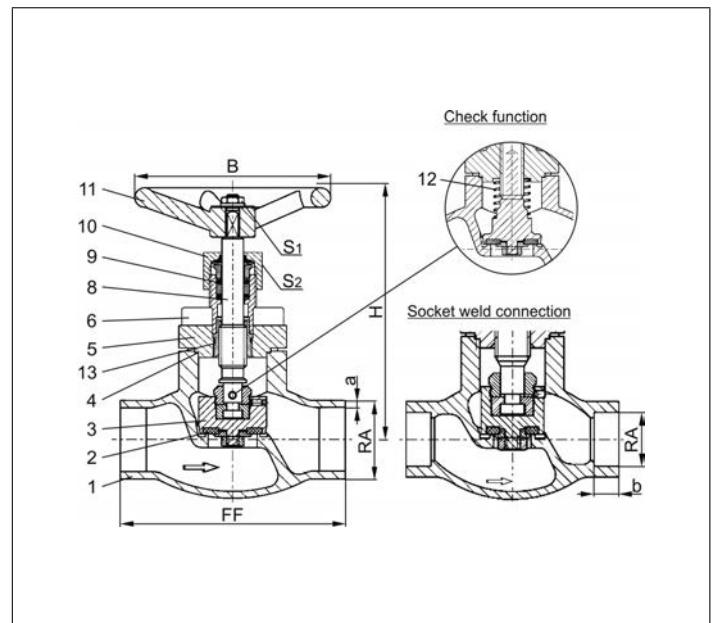

Type 01351 - Standard	Technical data														
	DN	10	15	15	20	25	32	40	40	50	65	80	100	150	
Nominal size	DN	10	15	15	20	25	32	40	40	50	65	80	100	150	
Dimension code	.X.	1012	1517	1521	2026	2533	3238	4042	4048	5060	657x	8088	0114	0168	
Face-to-face dimension	FF	70	85	85	100	115	115	130	130	155	205	245	280	400	
Height	H	140	140	140	140	140	170	175	175	200	260	310	350	420	
Outside pipe-Ø ISO 1127	RA	12.0	17.2	21.3	26.9	33.7	38.0	42.4	48.3	60.3	76.1	88.9	114.3	168.3	
Wall thickness pipe ISO 1127	a	1.0	1.6	2.0	2.0	2.0	2.0	2.0	2.0	2.0	2.6	3.2	6.0	7.1	
Outside pipe-Ø ASTM A312	RA	13.72	17.15	21.34	26.67	33.40	-	42.16	48.26	60.32	73.02	88.90	114.30	168.27	
Wall thickness pipe ASTM A312	a	dimensions acc. to S10 or S40													
Socket depth	b	6	10	10	13	13	-	13	13	16	16	16	20	20	
Handwheel-Ø	B	100	100	100	100	100	125	125	125	125	200	250	315	360	
Wrench size across flats	S ₁	10	10	10	10	10	13	13	13	13	13	13	13	18	
Wrench size across flats	S ₂	30	30	30	30	30	36	36	36	36	36	36	41	41	
Weight	ca. kg	1.0	1.25	1.3	1.7	2.0	2.8	4.2	4.2	6.7	10.7	16.0	23.0	54.1	
Kvs-Value	m ³ /h	1.6	3.8	4.3	6.7	11.5	14.0	20.6	22.6	37.1	71.1	104.0	170.0	350.0	
Cv-Value	gal/min	1.9	4.4	5.0	7.8	13.4	16.2	23.9	26.3	43.2	82.7	120.9	195.2	401.8	

Dimensions in mm.

Globe Valves

Type 01355 - Globe Valve



Cryogenic-Globe and Globe/Check Valves, PN50

Stainless steel body and topwork,
 "live loaded" gland packing
 "cleaned and degreased for oxygen service"

Part No. 01355.X.0001

Part No. 01355.X.5001 Globe/Check Valve

Female thread connection (G) acc. to ISO 228/1

Part No. 01355.X.0006

Part No. 01355.X.5006 Globe/Check Valve

Female thread connection NPT acc. to ANSI B 1.20.1

Available options - on request only:

- Female thread connection (R) acc. to ISO 7-Rc
- Valve with control disc (tapered design)



Applications:

Approved for air gases, vapours and cryogenic liquefied gases incl. LNG.

Working temperature: -196°C / -321°F (77K) up to +120°C / +248°F (393K)

Recommended working temperature: -60°C / -76°F (213K) up to +120°C / +248°F (393K)

Materials	DIN EN	ASTM
1 Body	1.4308	A 351 CF8
2 Valve seal	PTFE / Carbon filled (25%)	
3 Disc	1.4301	A 276 Grade 304
4 Bonnet gasket	PTFE	
5 Headpiece	1.4301 / 1.4308	A 276 Grade 304 / A 351 CF8
6 Bolts	1.4301/A2	A 194 B8
8 Stem	1.4301	A 276 Grade 304
9 Gland packing	Graphite / PTFE	
10 Gland nut	1.4305	A 276 Grade 303
11 Handwheel	Aluminium alloy	
12 Spring	1.4310	A 313 Grade 301
13 Bush	CW452K	B 159 UNS C51900

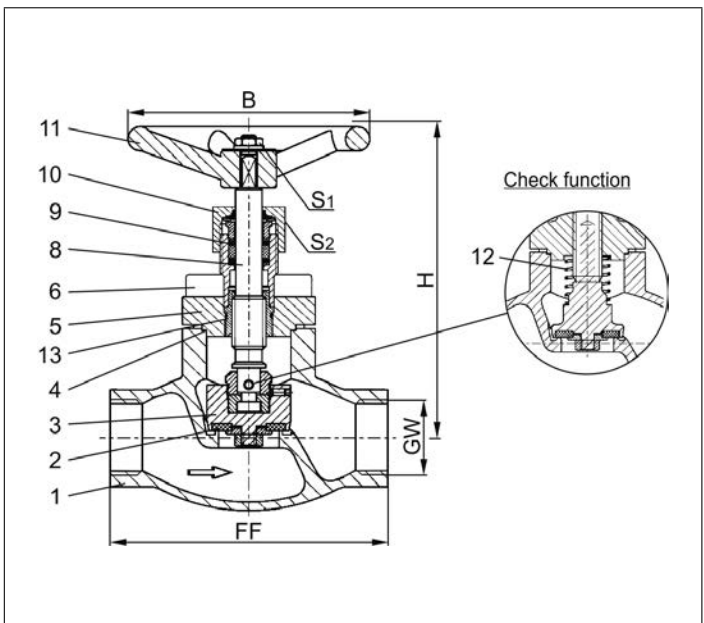

Standard marking acc. to Pressure Equipment Directive 97/23/EC (PED).



Type 01355 - Standard design	Technical data								
Nominal size	DN	10	10	15	20	25	40	40	50
Thread size	GW	1/4	3/8	1/2	3/4	1	1-1/4	1-1/2	2
Dimension code	.X.	0200	0300	0400	0600	1000	1200	1400	2000
Face-to-face dimension	FF	70	70	85	100	115	130	130	155
Height	H	140	140	140	140	140	175	175	200
Handwheel-Ø	B	100	100	100	100	100	125	125	125
Wrench size across flats	S ₁	10	10	10	10	10	13	13	13
Wrench size across flats	S ₂	30	30	30	30	30	36	36	36
Weight	ca. kg	1.0	1.0	1.3	1.7	2.0	4.2	4.2	6.7
Kvs-Value	m ³ /h	1.6	2.2	4.3	6.7	11.5	20.6	22.6	37.1
Cv-Value	gal/min	1.9	2.6	5.0	7.8	13.4	23.9	26.3	43.2

Dimensions in mm.

Globe Valves

Type 03351 - Globe Valve, DIN EN Flanges



Cryogenic-Globe and Globe/Check Valves, PN40

Stainless steel body and topwork,
 "live loaded" gland packing
 "cleaned and degreased for oxygen service"

Part No. 03351.X.0002

Part No. 03351.X.5002 Globe/Check Valve

Flanged connection acc. to DIN EN 1092-1 PN40

Available options - on request only:

- Valve with control disc (tapered design)
- Nominal sizes DN15, DN20 and DN150 with welded flange



Applications:

Approved for air gases, vapours and cryogenic liquefied gases incl. LNG.

Working temperature: -196°C / -321°F (77K) up to +120°C / +248°F (393K)

Recommended working temperature: -60°C / -76°F (213K) up to +120°C / +248°F (393K)

Materials	DIN EN	ASTM
1 Body	1.4308	A 351 CF8
2 Valve seal up to DN50	PTFE / Carbon filled (25%)	
2a Valve seal from DN65	PTFE	
3 Disc	1.4301	A 276 Grade 304
4 Bonnet gasket	PTFE	
5 Headpiece	1.4301 / 1.4308	A 276 Grade 304 / A 351 CF8
6 Bolts	1.4301/A2	A 194 B8
8 Stem	1.4301	A 276 Grade 304
9 Gland packing	Graphite / PTFE	
10 Gland nut	1.4305	A 276 Grade 303
11 Handwheel	Aluminium alloy	
12 Spring	1.4310	A 313 Grade 301
13 Bush	CW452K	B 159 UNS C51900

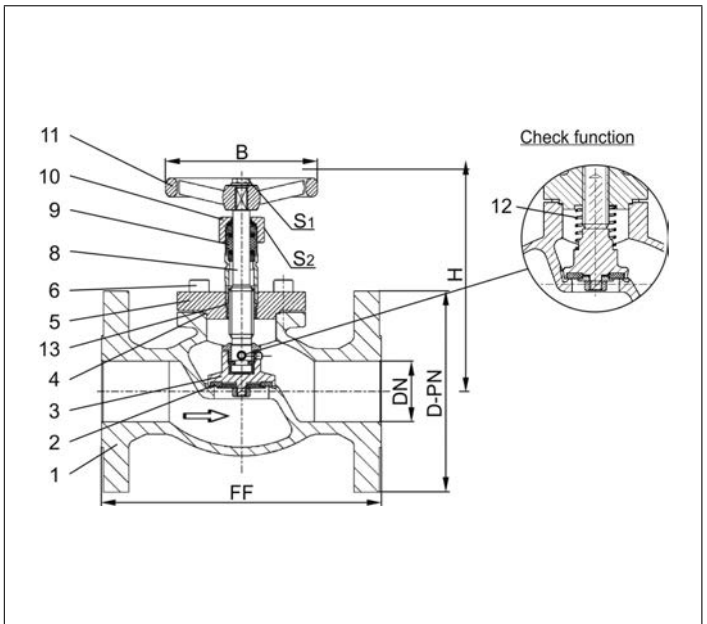

Standard marking acc. to Pressure Equipment Directive 97/23/EC (PED).



Type 03351 - Standard design	Technical data						
Nominal size	DN	25	40	50	65	80	100
Dimension code - Flange EN 1092-1 PN40	.X.	0250	0400	0500	0650	0800	1000
Flange-Ø	D-PN	115	150	165	185	200	235
Face-to-face dimension	FF	160	200	230	290	310	350
Height	H	140	170	200	260	310	350
Handwheel-Ø	B	100	125	125	200	250	315
Wrench size across flats	S ₁	10	13	13	13	13	13
Wrench size across flats	S ₂	30	36	36	36	36	41
Weight	ca. kg	4.5	9.1	12.9	20.6	27.6	42.0
Kvs-Value	m ³ /h	11.5	22.6	37.1	71.1	104.0	170.0
Cv-Value	gal/min	13.4	26.3	43.2	82.7	120.9	195.2

Dimensions in mm.

Globe Valves

Type 03351 - Globe Valve, ANSI Flanges



Cryogenic-Globe and Globe/Check Valves, class 300

Stainless steel body and topwork,
 "live loaded" gland packing
 "cleaned and degreased for oxygen service"

Part No. 03351.X.0003

Part No. 03351.X.5003 Globe/Check Valve

Flanged connection acc. to ANSI B16.5 class 300

Available options - on request only:

- Valve with control disc (tapered design)
- Nominal sizes DN15, DN20 and DN150 with welded flange



Applications:

Approved for air gases, vapours and cryogenic liquefied gases incl. LNG.

Working temperature: -196°C / -321°F (77K) up to +120°C / +248°F (393K)

Recommended working temperature: -60°C / -76°F (213K) up to +120°C / +248°F (393K)

Materials	DIN EN	ASTM
1 Body	1.4308	A 351 CF8
2 Valve seal up to DN50	PTFE / Carbon filled (25%)	
2a Valve seal from DN65	PTFE	
3 Disc	1.4301	A 276 Grade 304
4 Bonnet gasket	PTFE	
5 Headpiece	1.4301 / 1.4308	A 276 Grade 304 / A 351 CF8
6 Bolts	1.4301/A2	A 194 B8
8 Stem	1.4301	A 276 Grade 304
9 Gland packing	Graphite / PTFE	
10 Gland nut	1.4305	A 276 Grade 303
11 Handwheel	Aluminium alloy	
12 Spring	1.4310	A 313 Grade 301
13 Bush	CW452K	B 159 UNS C51900

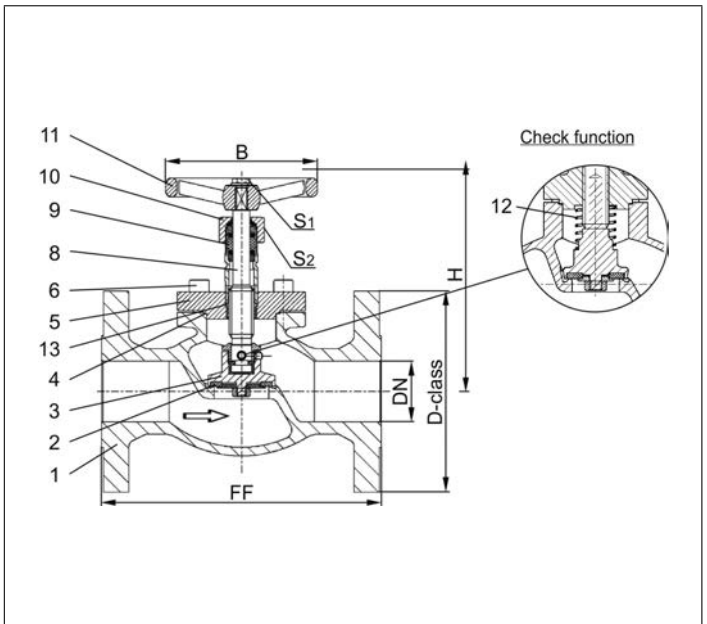

Standard marking acc. to Pressure Equipment Directive 97/23/EC (PED).



Type 03351 - Standard design	Technical data						
	DN	25	40	50	65	80	100
Nominal size	.X.	1000	1400	2000	2400	3000	4000
Dimension code - Flange ANSI B16.5 class 300	D-class	123.9	155.4	165	190.5	209.5	254
Flange-Ø	FF	160	200	230	290	310	350
Face-to-face dimension	H	140	170	200	260	310	350
Height	B	100	125	125	200	250	315
Handwheel-Ø	S ₁	10	13	13	13	13	13
Wrench size across flats	S ₂	30	36	36	36	36	41
Wrench size across flats	ca. kg	4.5	9.1	12.9	20.6	27.6	42.0
Weight	m ³ /h	11.5	22.6	37.1	71.1	104.0	170.0
Kvs-Value	gal/min	13.4	26.3	43.2	82.7	120.9	195.2
Cv-Value							

Dimensions in mm.

Globe Valves

Type 01311 - Globe Valve



Cryogenic-Globe and Globe/Check Valves, PN50

Bronze body and topwork
 "live loaded" gland packing
 "cleaned and degreased for oxygen service"

- Part No. 01311.X.0010 (H=270mm)**
- Part No. 01311.X.0020 (H=370mm)**
- Part No. 01311.X.5010 (H=270mm) Globe/Check Valve**
- Part No. 01311.X.5020 (H=370mm) Globe/Check Valve**
- Socket end for copper pipes acc. to DIN EN 12449 or ASTM B88

- Available options - on request only:
- Socket end for stainless steel stubs acc. to ISO 1127
 - Extension H up to 900mm
 - Valve with control disc (tapered design)



Applications:

Approved for air gases, vapours and cryogenic liquefied gases incl. LNG.
 Working temperature: -196°C / -321°F (77K) up to +120°C / +248°F (393K)

Materials	DIN EN	ASTM
1 Body	CC491K	B 62 UNS C83600
2 Valve seal	PTFE / Carbon filled (25%)	
3 Disc	CW614N	B 283 UNS C38500
4 Bonnet gasket	PTFE	
5 Headpiece	CC493K	B 505 UNS C93200
6 Bolts	1.4301/A2 A 194 B8	
7 Elongation tube	1.4541 A 213 TP 321	
8 Stem	1.4301 A 276 Grade 304	
9 Gland packing	Graphite / PTFE	
10 Gland nut	CW614N	B 283 UNS C38500
11 Handwheel	Aluminium alloy	
12 Spring	CW452K	B 159 UNS C51900

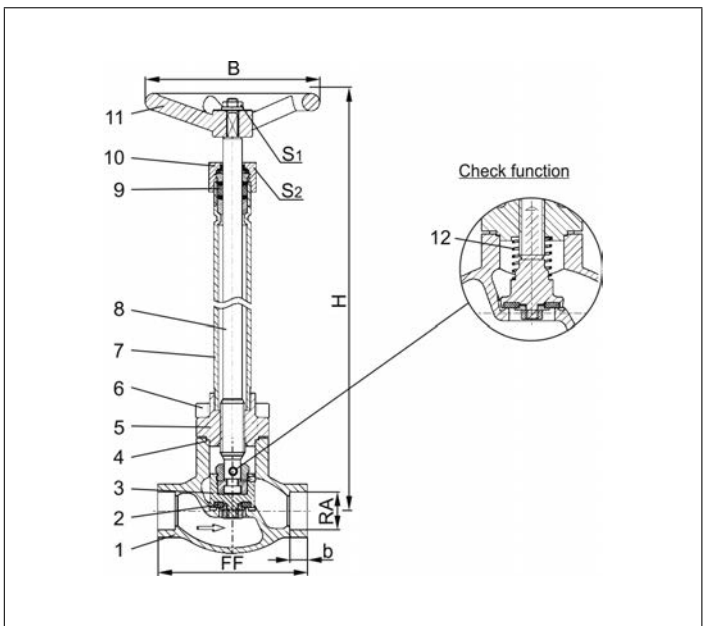

Standard marking acc. to Pressure Equipment Directive 97/23/EC (PED).



Type 01311 - Standard design	Technical data							
	DN	10	15	20	25	32	40	50
Nominal size	DN	10	15	20	25	32	40	50
Dimension code	.X.	X=DNRA. Example: valve DN15 for copper stub RA _ø 18mm. X=1518						
Face-to-face dimension	FF	60	85	85	115	115	140	160
Height	H	270mm or 370mm						
Outside pipe-Ø	RA	dependent on order						
Socket depth	b	6	6	8	8	10	13	20
Handwheel-Ø	B	100	100	100	100	125	125	125
Wrench size across flats	S ₁	10	10	10	10	13	13	13
Wrench size across flats	S ₂	30	30	30	30	36	36	36
Weight	ca. kg	1.4	1.7	2.1	2.4	3.3	4.7	7.2
Kvs-Value	m ³ /h	1.6	4.3	6.7	11.5	12.1	22.6	37.1
Cv-Value	gal/min	1.9	5.0	7.8	13.4	14.1	26.3	43.2

Dimensions in mm.

Globe Valves

Type 01311 - Globe Valve



Cryogenic-Globe and Globe/Check Valves, PN50

- Bronze body and topwork
- "live loaded" gland packing
- "cleaned and degreased for oxygen service"

- Part No. 01311.X.0018 (H=270mm)**
- Part No. 01311.X.0028 (H=370mm)**
- Part No. 01311.X.5018 (H=270mm) Globe/Check Valve**
- Part No. 01311.X.5028 (H=370mm) Globe/Check Valve**
- Complete with copper stubs acc. to DIN EN 12449

- Available options - on request only:
- Extension H up to 900mm
 - Valve with control disc (tapered design)



Applications:

Approved for air gases, vapours and cryogenic liquefied gases incl. LNG.
Working temperature: -196°C / -321°F (77K) up to +120°C / +248°F (393K)

Materials	DIN EN	ASTM
1 Body	CC491K	B 62 UNS C83600
2 Valve seal	PTFE / Carbon filled (25%)	
3 Disc	CW614N	B 283 UNS C38500
4 Bonnet gasket	PTFE	
5 Headpiece	CC493K	B 505 UNS C93200
6 Bolts	1.4301/A2 A 194 B8	
7 Elongation tube	1.4541	A 213 TP 321
8 Stem	1.4301	A 276 Grade 304
9 Gland packing	Graphite / PTFE	
10 Gland nut	CW614N	B 283 UNS C38500
11 Handwheel	Aluminium alloy	
12 Spring	CW452K	B 159 UNS C51900
13 Copper stubs	CW024A	B 152 UNS C12200

Standard marking acc. to Pressure Equipment Directive 97/23/EC (PED).

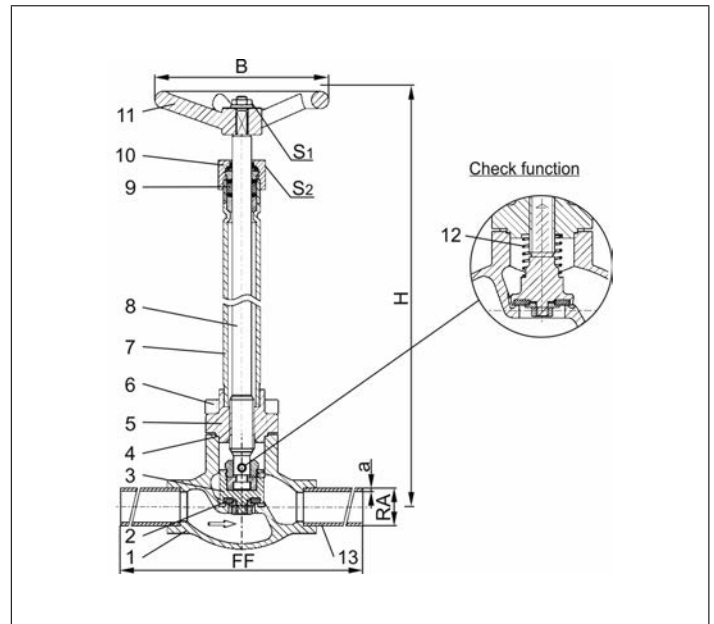

Type 01311 - Standard design	Technical data								
	DN	10	15	15	20	25	32	40	50
Nominal size	DN	10	15	15	20	25	32	40	50
Dimension code	.X.	1012	1515	1518	2022	2528	3235	4042	5054
Face-to-face dimension	FF	360	385	385	385	415	415	420	460
Height	H	270mm or 370mm							
Outside pipe-Ø	RA	12.0	15.0	18.0	22.0	28.0	35.0	42.0	54.0
Wall thickness pipe	a	1.0	1.5	1.5	1.5	1.5	1.5	1.5	2.0
Handwheel-Ø	B	100	100	100	100	100	125	125	125
Wrench size across flats	S ₁	10	10	10	10	10	13	13	13
Wrench size across flats	S ₂	30	30	30	30	30	36	36	36
Weight	ca. kg	1.5	1.9	1.9	2.4	2.8	3.7	5.2	7.8
Kvs-Value	m ³ /h	2.2	4.3	4.3	6.7	11.5	12.1	22.6	37.1
Cv-Value	gal/min	2.6	5.0	5.0	7.8	13.4	14.1	26.3	43.2

Dimensions in mm.

Globe Valves

Type 01311 - Globe Valve



Cryogenic-Globe and Globe/Check Valves, PN50

Bronze body and topwork
 "live loaded" gland packing
 "cleaned and degreased for oxygen service"

Part No. 01311.X.0017 (H=270mm)

Part No. 01311.X.0027 (H=370mm)

Part No. 01311.X.5017 (H=270mm) Globe/Check Valve

Part No. 01311.X.5027 (H=370mm) Globe/Check Valve

Complete with stainless steel stubs acc. to DIN EN 10216-5 or ASTM A312

Available options - on request only:

- Extension H up to 900mm
- Valve with control disc (tapered design)

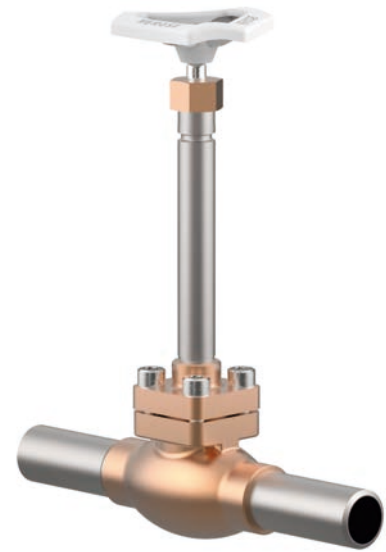

Applications:

Approved for air gases, vapours and cryogenic liquefied gases incl. LNG.

Working temperature: -196°C / -321°F (77K) up to +120°C / +248°F (393K)

Materials	DIN EN	ASTM
1 Body	CC491K	B 62 UNS C83600
2 Valve seal	PTFE / Carbon filled (25%)	
3 Disc	CW614N	B 283 UNS C38500
4 Bonnet gasket	PTFE	
5 Headpiece	CC493K	B 505 UNS C93200
6 Bolts	1.4301/A2 A 194 B8	
7 Elongation tube	1.4541 A 213 TP 321	
8 Stem	1.4301 A 276 Grade 304	
9 Gland packing	Graphite / PTFE	
10 Gland nut	CW614N	B 283 UNS C38500
11 Handwheel	Aluminium alloy	
12 Spring	CW452K	B 159 UNS C51900
13 Stainless steel stubs	1.4306	A 312 TP304L

Standard marking acc. to Pressure Equipment Directive 97/23/EC (PED).

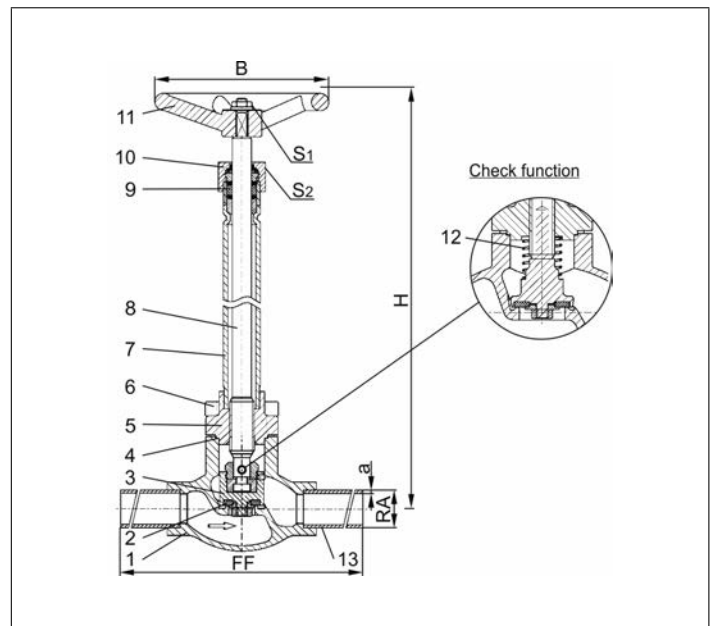

Type 01311 - Standard design	Technical data								
Nominal size	DN	10	10	15	20	25	32	40	50
Dimension code	.X.	1012	1017	1521	2027	2533	3242	4048	5060
Face-to-face dimension	FF	210	210	235	235	265	265	290	310
Height	H	270mm or 370mm							
Outside pipe-Ø ISO 1127	RA	12.0	17.2	21.3	26.9	33.7	42.4	48.3	60.3
Wall thickness pipe ISO 1127	a	1.0	2.3	2.6	2.9	3.2	3.2	3.6	3.6
Outside pipe-Ø ASTM A312	RA	-	17.15	21.34	26.67	33.4	42.16	48.26	60.33
Wall thickness pipe ASTM A312	a	dimensions acc. to S10 or S40							
Handwheel-Ø	B	100	100	100	100	100	125	125	125
Wrench size across flats	S ₁	10	10	10	10	10	13	13	13
Wrench size across flats	S ₂	30	30	30	30	30	36	36	36
Weight	ca. kg	1.45	1.55	2.0	2.4	2.8	3.7	5.2	7.8
Kvs-Value	m ³ /h	2.2	2.2	4.3	6.7	11.5	12.1	22.6	37.1
Cv-Value	gal/min	2.6	2.6	5.0	7.8	13.4	14.1	26.3	43.2

Dimensions in mm.

Globe Valves

Type 01315 - Globe Valve



Cryogenic-Globe and Globe/Check Valves, PN50

Bronze body and topwork
 "live loaded" gland packing
 "cleaned and degreased for oxygen service"

Part No. 01315.X.0011 (H=270mm)
Part No. 01315.X.0021 (H=370mm)
Part No. 01315.X.5011 (H=270mm) Globe/Check Valve
Part No. 01315.X.5021 (H=370mm) Globe/Check Valve
 Female thread connection (G) acc. to ISO 228/1

Part No. 01315.X.0016 (H=270mm)
Part No. 01315.X.0026 (H=370mm)
Part No. 01315.X.5016 (H=270mm) Globe/Check Valve
Part No. 01315.X.5026 (H=370mm) Globe/Check Valve
 Female thread connection NPT acc. to ANSI B 1.20.1

Available options - on request only:
 · Female thread connection (R) acc. to ISO 7-Rc
 · Extension H up to 900mm
 · Valve with control disc (tapered design)

Applications:

Approved for air gases, vapours and cryogenic liquefied gases incl. LNG.
 Working temperature: -196°C / -321°F (77K) up to +120°C / +248°F (393K)



Materials	DIN EN	ASTM
1 Body	CC491K	B 62 UNS C83600
2 Valve seal	PTFE / Carbon filled (25%)	
3 Disc	CW614N	B 283 UNS C38500
4 Bonnet gasket	PTFE	
5 Headpiece	CC493K	B 505 UNS C93200
6 Bolts	1.4301/A2 A 194 B8	
7 Elongation tube	1.4541 A 213 TP 321	
8 Stem	1.4301 A 276 Grade 304	
9 Gland packing	Graphite / PTFE	
10 Gland nut	CW614N	B 283 UNS C38500
11 Handwheel	Aluminium alloy	
12 Spring	CW452K	B 159 UNS C51900

Standard marking acc. to Pressure Equipment Directive 97/23/EC (PED).

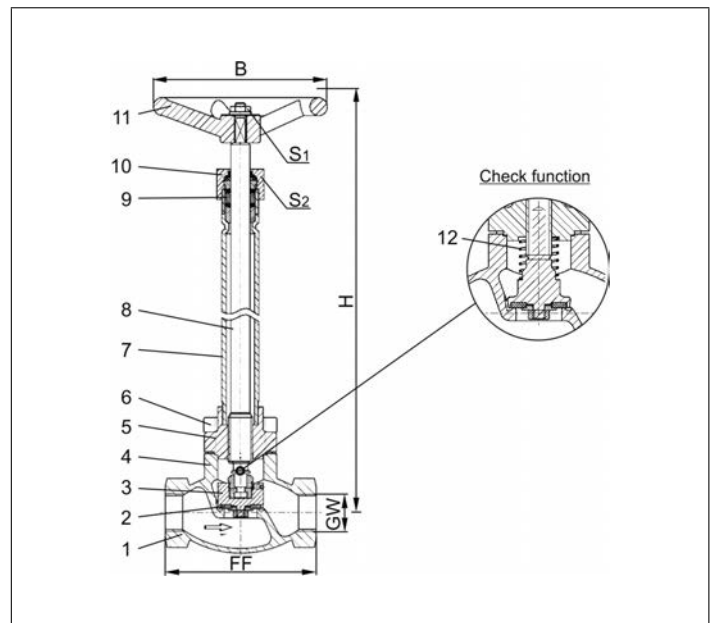

Type 01315 - Standard design	Technical data								
Nominal size	DN	10	10	15	20	25	32	40	50
Thread size	GW	1/4	3/8	1/2	3/4	1	1-1/4	1-1/2	2
Dimension code	.X.	0200	0300	0400	0600	1000	1200	1400	2000
Face-to-face dimension	FF	60	60	85	85	115	115	140	160
Height	H	270mm or 370mm							
Handwheel-Ø	B	100	100	100	100	100	125	125	125
Wrench size across flats	S ₁	10	10	10	10	10	13	13	13
Wrench size across flats	S ₂	30	30	30	30	30	36	36	36
Weight	ca. kg	1.4	1.4	1.7	2.1	2.4	3.3	4.7	7.2
Kvs-Value	m ³ /h	1.6	2.2	4.3	6.7	11.5	20.6	22.6	37.1
Cv-Value	gal/min	1.9	2.6	5.0	7.8	13.4	23.9	26.3	43.2

Dimensions in mm.

Globe Valves

Type 02411 - Globe Valve



Cryogenic-Globe and Globe/Check Valves, PN50

Bronze body and topwork,
 "live loaded" gland packing
 "cleaned and degreased for oxygen service"

- Part No. 02411.X.0011 (H=270mm)
 - Part No. 02411.X.0021 (H=370mm)
 - Part No. 02411.X.5011 (H=270mm) Globe/Check Valve
 - Part No. 02411.X.5021 (H=370mm) Globe/Check Valve
- Male thread for union connection

Available options - on request only:

- Extension H up to 900mm
- Valve with control disc (tapered design)



Applications:

Approved for air gases, vapours and cryogenic liquefied gases incl. LNG.
 Working temperature: -196°C / -321°F (77K) up to +120°C / +248°F (393K)

Materials	DIN EN	ASTM
1 Body	CC491K	B 62 UNS C83600
2 Valve seal	PTFE / Carbon filled (25%)	
3 Disc	CW614N	B 283 UNS C38500
4 Bonnet gasket	PTFE	
5 Headpiece	CC493K	B 505 UNS C93200
6 Bolts	1.4301/A2 A 194 B8	
7 Elongation tube	1.4541 A 213 TP 321	
8 Stem	1.4301 A 276 Grade 304	
9 Gland packing	Graphite / PTFE	
10 Gland nut	CW614N	B 283 UNS C38500
11 Handwheel	Aluminium alloy	
12 Spring	CW452K	B 159 UNS C51900

Standard marking acc. to Pressure Equipment Directive 97/23/EC (PED).

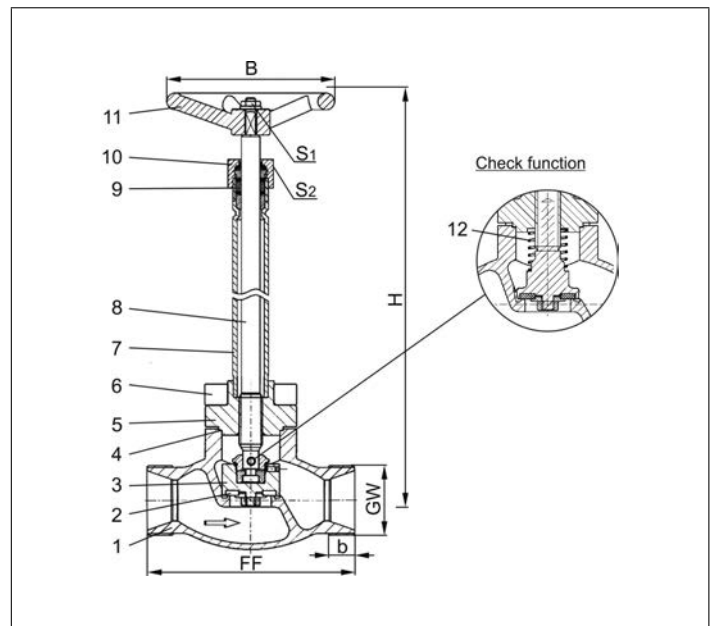

Type 02411 - Standard design	Technical data					
Nominal size	DN	10	20	32	40	50
Dimension code	.X.	0100	0200	0320	0400	0500
Face-to-face dimension	FF	60	85	115	140	160
Height	H	270 mm or 370 mm				
Union thread	GW	M26x1.5	M40x2.0	M55x2.0	M65x2.0	M78x2.0
Thread length	b	10	11	14	17	20
Handwheel-Ø	B	100	100	125	125	125
Wrench size across flats	S ₁	10	10	13	13	13
Wrench size across flats	S ₂	30	30	36	36	36
Weight	ca. kg	1.4	2.1	3.3	4.7	7.2
Kvs-Value	m ³ /h	2.2	6.7	12.1	22.6	37.1
Cv-Value	gal/min	2.6	7.8	14.1	26.3	43.2

Dimensions in mm.

Globe Valves

Type 02411 - Globe Valve



Cryogenic-Globe and Globe/Check Valves, PN50

Bronze body and topwork,
 "live loaded" gland packing
 "cleaned and degreased for oxygen service"

Part No. 02411.X.0018 (H=270mm)

Part No. 02411.X.0028 (H=370mm)

Part No. 02411.X.5018 (H=270mm) Globe/Check Valve

Part No. 02411.X.5028 (H=370mm) Globe/Check Valve

Completed with union type braze fittings for copper pipes acc. to DIN EN 12449 or ASTM B88

Available options - on request only:

- Extension H up to 900mm
- Valve with control disc (tapered design)



Applications:

Approved for air gases, vapours and cryogenic liquefied gases incl. LNG.

Working temperature: -196°C / -321°F (77K) up to +120°C / +248°F (393K)

Materials	DIN EN	ASTM
1 Body	CC491K	B 62 UNS C83600
2 Valve seal	PTFE / Carbon filled (25%)	
3 Disc	CW614N	B 283 UNS C38500
4 Bonnet gasket	PTFE	
5 Headpiece	CC493K	B 505 UNS C93200
6 Bolts	1.4301/A2 A 194 B8	
7 Elongation tube	1.4541 A 213 TP 321	
8 Stem	1.4301 A 276 Grade 304	
9 Gland packing	Graphite / PTFE	
10 Gland nut	CW614N	B 283 UNS C38500
11 Handwheel	Aluminium alloy	
12 Spring	CW452K	B 159 UNS C51900
13 Braze fitting	CC493K	B 505 UNS C93200
14 Union nut	CC493K	B 505 UNS C93200

Standard marking acc. to Pressure Equipment Directive 97/23/EC (PED).

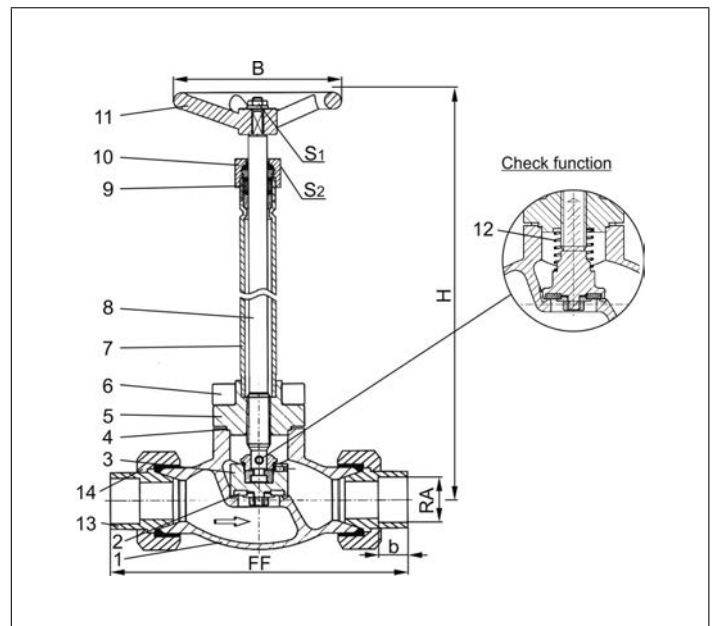

Type 02411 - Standard design	Technical data									
		DN	10	10	20	20	32	32	40	50
Nominal size	DN		10	10	20	20	32	32	40	50
Dimension code	.X.	1012	1015	1518	2022	2528	3235	4042	5054	
Face-to-face dimension	FF	98	98	132	132	171	171	230	230	
Height	H	270 mm or 370 mm								
Outside pipe-Ø	RA	12.0	15.0	18.0	22.0	28.0	35.0	42.0	54.0	
Socket depth	b	11	11	14	14	17	17	17	17	
Handwheel-Ø	B	100	100	100	100	125	125	125	125	
Wrench size across flats	S ₁	10	10	10	10	13	13	13	13	
Wrench size across flats	S ₂	30	30	30	30	36	36	36	36	
Weight	ca. kg	1.5	1.5	2.8	2.8	4.5	4.5	6.8	10.0	
Kvs-Value	m ³ /h	1.6	2.2	6.0	6.7	11.5	12.1	22.6	37.1	
Cv-Value	gal/min	1.9	2.6	7.1	7.8	13.4	14.1	26.3	43.2	

Dimensions in mm.

Globe Valves

Type 02411 - Globe Valve



Cryogenic-Globe and Globe/Check Valves, PN50

Bronze body and topwork,
 "live loaded" gland packing
 "cleaned and degreased for oxygen service"

Part No. 02411.X.0017 (H=270mm)

Part No. 02411.X.0027 (H=370mm)

Part No. 02411.X.5017 (H=270mm) Globe/Check Valve

Part No. 02411.X.5027 (H=370mm) Globe/Check Valve

Completed with union type butt weld fittings for stainless steel pipes
 acc. to ISO 1127 or ASTM A312

Available options - on request only:

- Extension H up to 900mm
- Valve with control disc (tapered design)

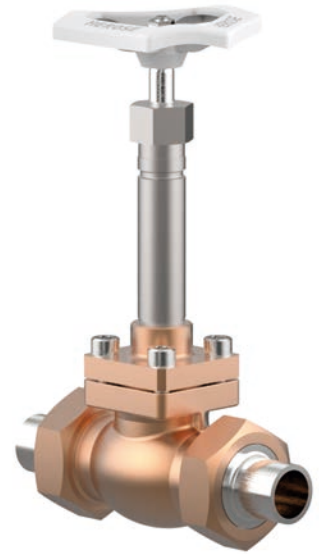

Applications:

Approved for air gases, vapours and cryogenic liquefied gases incl. LNG.

Working temperature: -196°C / -321°F (77K) up to +120°C / +248°F (393K)

Materials	DIN EN	ASTM
1 Body	CC491K	B 62 UNS C83600
2 Valve seal	PTFE / Carbon filled (25%)	
3 Disc	CW614N	B 283 UNS C38500
4 Bonnet gasket	PTFE	
5 Headpiece	CC493K	B 505 UNS C93200
6 Bolts	1.4301/A2 A 194 B8	
7 Elongation tube	1.4541 A 213 TP 321	
8 Stem	1.4301 A 276 Grade 304	
9 Gland packing	Graphite / PTFE	
10 Gland nut	CW614N	B 283 UNS C38500
11 Handwheel	Aluminium alloy	
12 Spring	CW452K	B 159 UNS C51900
13 Weld fitting	1.4301 A 276 Grade 304	
14 Union nut	CC493K	B 505 UNS C93200

Standard marking acc. to Pressure Equipment
 Directive 97/23/EC (PED).

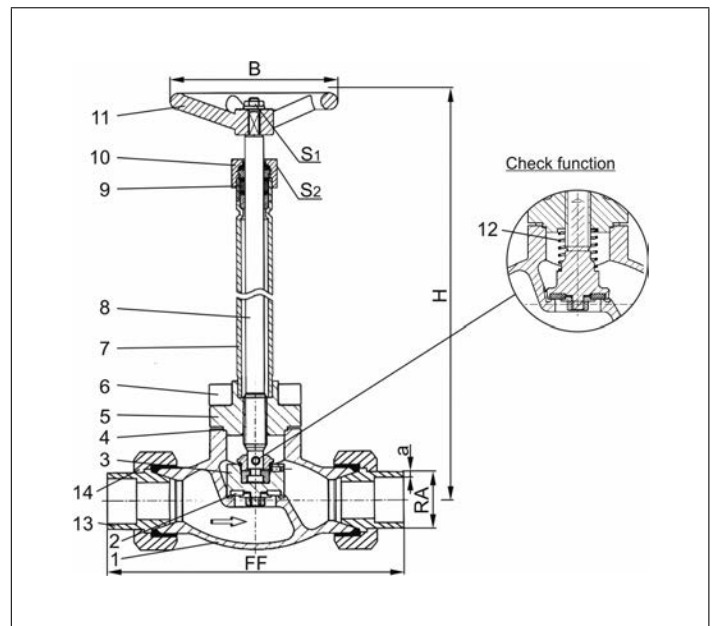

Type 02411 - Standard design	Technical data								
Nominal size	DN	10	10	20	20	32	32	40	50
Dimension code	.X.	1012	1017	1521	2027	2533	3242	4048	5060
Face-to-face dimension	FF	137	141	168	168	203	203	230	263
Height	H	270 mm or 370 mm							
Outside pipe-Ø ISO 1127	RA	12.0	17.2	21.3	26.9	33.7	42.4	48.3	60.3
Wall thickness pipe ISO 1127	a	1.0	2.3	2.6	2.0	3.2	2.0	3.6	3.6
Outside pipe-Ø ASTM A312	RA	-	17.15	21.34	26.67	33.40	42.16	48.26	60.33
Wall thickness pipe ASTM A312	a	dimensions acc. to S10 or S40							
Handwheel-Ø	B	100	100	100	100	125	125	125	125
Wrench size across flats	S ₁	10	10	10	10	13	13	13	13
Wrench size across flats	S ₂	30	30	30	30	36	36	36	36
Weight	ca. kg	1.5	1.5	2.8	2.8	4.5	4.5	6.8	10.0
Kvs-Value	m ³ /h	1.6	2.2	6.7	6.7	12.1	12.1	22.6	37.1
Cv-Value	gal/min	1.9	2.6	7.8	7.8	14.1	14.1	26.3	43.2

Dimensions in mm.

Globe Valves

Type 01321 - Globe Valve



Cryogenic-Globe and Globe/Check Valves, PN50 (DN100/150=PN40)

Stainless steel body and bronze topwork
 "live loaded" gland packing
 "cleaned and degreased for oxygen service"

Part No. 01321.X.001* (H = 270mm)

Part No. 01321.X.002* (H = 370mm)

Part No. 01321.X.501* (H = 270mm) Globe/Check Valve

Part No. 01321.X.502* (H = 370mm) Globe/Check Valve

*Butt weld connection for stainless steel pipes acc. to ISO 1127 or ASTM A312

Part No. 01321.X.0014 (H = 270mm)

Part No. 01321.X.0024 (H = 370mm)

Part No. 01321.X.5014 (H = 270mm) Globe/Check Valve

Part No. 01321.X.5024 (H = 370mm) Globe/Check Valve

Socket weld connection for stainless steel pipes acc. to ISO 1127 or ASTM A312

Available options - on request only:

- Welded stainless steel stubs acc. to ISO 1127 or ASTM A312 - length FF + 200mm
- Extension H up to 900mm
- Valve with control disc (tapered design)

Applications:

Approved for air gases, vapours and cryogenic liquefied gases incl. LNG.

Working temperature: -196°C / -321°F (77K) up to +120°C / +248°F (393K)



Materials	DIN EN	ASTM
1 Body	1.4308	A 351 CF8
2 Valve seal up to DN50	PTFE / Carbon filled (25%)	
2a Valve seal from DN65	PTFE	
3 Disc	CW614N	B 283 UNS C38500
4 Bonnet gasket	PTFE	
5 Headpiece	CC493K	B 505 UNS C93200
6 Bolts	1.4301/A2	A 194 B8
7 Elongation tube	1.4541	A 213 TP 321
8 Stem	1.4301	A 276 Grade 304
9 Gland packing	Graphite / PTFE	
10 Gland nut	CW614N	B 283 UNS C38500
11 Handwheel	Aluminium alloy	
12 Spring	CW452K	B 159 UNS C51900

Standard marking acc. to Pressure Equipment Directive 97/23/EC (PED).

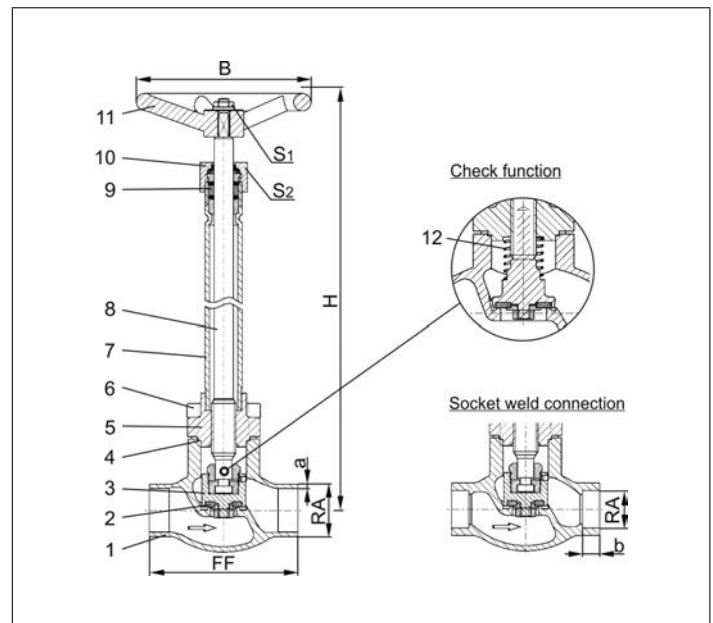

Type 01321 - Standard	Technical data													
	DN	10	15	15	20	25	32	40	40	50	65	80	100	150
Nominal size	.X.	1012	1517	1521	2026	2533	3238	4042	4048	5060	657x	8088	0114	0168
Dimension code	FF	70	85	85	100	115	115	130	130	155	205	245	280	400
Face-to-face dimension	H	270mm or 370mm												
Height	RA	12.0	17.2	21.3	26.9	33.7	38.0	42.4	48.3	60.3	76.1	88.9	114.3	168.3
Outside pipe-Ø ISO 1127	a	1.0	1.6	2.0	2.0	2.0	2.0	2.0	2.0	2.0	2.6	3.2	6.0	7.1
Wall thickness pipe ISO 1127	RA	13.72	17.15	21.34	26.67	33.40	-	42.16	48.26	60.32	73.02	88.90	114.30	168.27
Outside pipe-Ø ASTM A312	a	dimensions acc. to S10 or S40												
Wall thickness pipe ASTM A312	b	6	10	10	13	13	-	13	13	16	16	16	20	20
Socket depth	B	100	100	100	100	100	125	125	125	125	200	250	315	360
Handwheel-Ø	S ₁	10	10	10	10	10	13	13	13	13	13	13	13	19
Wrench size across flats	S ₂	30	30	30	30	30	36	36	36	36	36	36	41	41
Wrench size across flats	ca. kg	1.4	1.65	1.7	2.1	2.4	3.3	4.7	4.7	7.2	12.7	17.0	24.5	54.0
Weight	m ³ /h	1.6	3.8	4.3	6.7	11.5	14.0	20.6	22.6	37.1	71.1	104.0	170.0	350.0
Kvs-Value	gal/min	1.9	4.4	5.0	7.8	13.4	16.2	23.9	26.3	43.2	82.7	120.9	195.2	401.8
Cv-Value														

Dimensions in mm. Compliance of tightness requirements acc. to EN 1626 for DN150 up to 20 bar differential pressure. In the range of >20-40 bar, 350-700ml (1 bar, 20°C [68°F]) are reached.

Globe Valves

Type 01325 - Globe Valve



Cryogenic-Globe and Globe/Check Valves, PN50

Stainless steel body and bronze topwork
 "live loaded" gland packing
 "cleaned and degreased for oxygen service"

Part No. 01325.X.0011 (H = 270mm)
Part No. 01325.X.0021 (H = 370mm)
Part No. 01325.X.5011 (H = 270mm) Globe/Check Valve
Part No. 01325.X.5021 (H = 370mm) Globe/Check Valve
 Female thread connection (G) acc. to ISO 228/1

Part No. 01325.X.0016 (H = 270mm)
Part No. 01325.X.0026 (H = 370mm)
Part No. 01325.X.5016 (H = 270mm) Globe/Check Valve
Part No. 01325.X.5026 (H = 370mm) Globe/Check Valve
 Female thread connection NPT acc. to ANSI B 1.20.1

Available options - on request only:
 · Female thread connection (R) acc. to ISO 7-Rc
 · Extension H up to 900mm
 · Valve with control disc (tapered design)

Applications:

Approved for air gases, vapours and cryogenic liquefied gases incl. LNG.
 Working temperature: -196°C / -321°F (77K) up to +120°C / +248°F (393K)



Materials	DIN EN	ASTM
1 Body	1.4308	A 351 CF8
2 Valve seal	PTFE / Carbon filled (25%)	
3 Disc	CW614N	B 283 UNS C38500
4 Bonnet gasket	PTFE	
5 Headpiece	CC493K	B 505 UNS C93200
6 Bolts	1.4301/A2	A 194 B8
7 Elongation tube	1.4541	A 213 TP 321
8 Stem	1.4301	A 276 Grade 304
9 Gland packing	Graphite / PTFE	
10 Gland nut	CW614N	B 283 UNS C38500
11 Handwheel	Aluminium alloy	
12 Spring	CW452K	B 159 UNS C51900

Standard marking acc. to Pressure Equipment Directive 97/23/EC (PED).

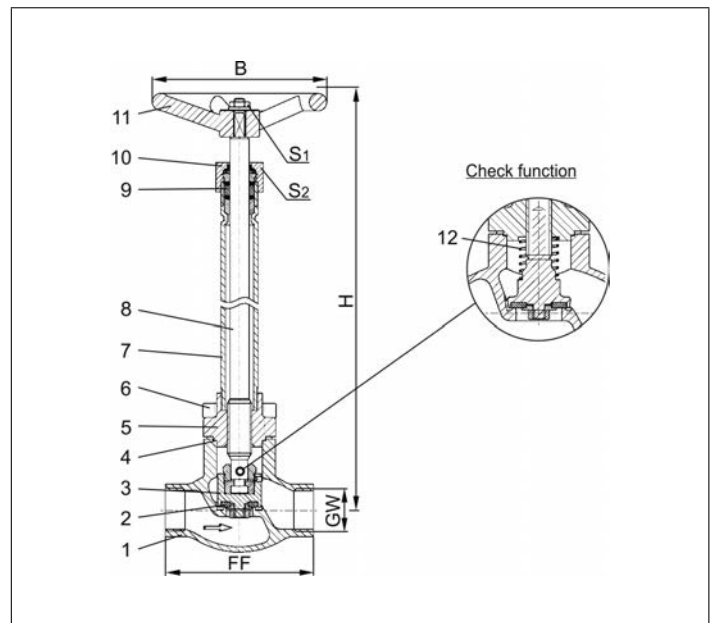

Type 01325 - Standard design	Technical data								
Nominal size	DN	10	10	15	20	25	40	40	50
Thread size	GW	1/4	3/8	1/2	3/4	1	1-1/4	1-1/2	2
Dimension code	.X.	0200	0300	0400	0600	1000	1200	1400	2000
Face-to-face dimension	FF	70	70	85	100	115	130	130	155
Height	H	270mm or 370mm							
Handwheel-Ø	B	100	100	100	100	100	125	125	125
Wrench size across flats	S ₁	10	10	10	10	10	13	13	13
Wrench size across flats	S ₂	30	30	30	30	30	36	36	36
Weight	ca. kg	1.4	1.4	1.7	2.1	2.4	4.7	4.7	7.2
Kvs-Value	m ³ /h	1.6	2.2	4.3	6.7	11.5	20.6	22.6	37.1
Cv-Value	gal/min	1.9	2.6	5.0	7.8	13.4	23.9	26.3	43.2

Dimensions in mm.

Globe Valves

Type 03321 - Globe Valve, DIN EN Flanges



Cryogenic-Globe and Globe/Check Valves, PN16

Stainless steel body and bronze topwork,
 "live loaded" gland packing
 "cleaned and degreased for oxygen service"

Part No. 03321.X.0014 (H = 270mm)

Part No. 03321.X.0024 (H = 370mm)

Part No. 03321.X.5014 (H = 270mm) Globe/Check Valve

Part No. 03321.X.5024 (H = 370mm) Globe/Check Valve

Flanged connection acc. to DIN EN 1092-1 PN16

Available options - on request only:

- Extension H up to 900mm
- Valve with control disc (tapered design)
- Nominal sizes DN15, DN20 and DN150 with welded flange



Applications:

Approved for air gases, vapours and cryogenic liquefied gases incl. LNG.

Working temperature: -196°C / -321°F (77K) up to +120°C / +248°F (393K)

Materials	DIN EN	ASTM
1 Body	1.4308	A 351 CF8
2 Valve seal up to DN50	PTFE / Carbon filled (25%)	
2a Valve seal from DN65	PTFE	
3 Disc	CW614N	B 283 UNS C38500
4 Bonnet gasket	PTFE	
5 Headpiece	CC493K	B 505 UNS C93200
6 Bolts	1.4301/A2	A 194 B8
7 Elongation tube	1.4541	A 213 TP 321
8 Stem	1.4301	A 276 Grade 304
9 Gland packing	Graphite / PTFE	
10 Gland nut	CW614N	B 283 UNS C38500
11 Handwheel	Aluminium alloy	
12 Spring	CW452K	B 159 UNS C51900

Standard marking acc. to Pressure Equipment Directive 97/23/EC (PED).

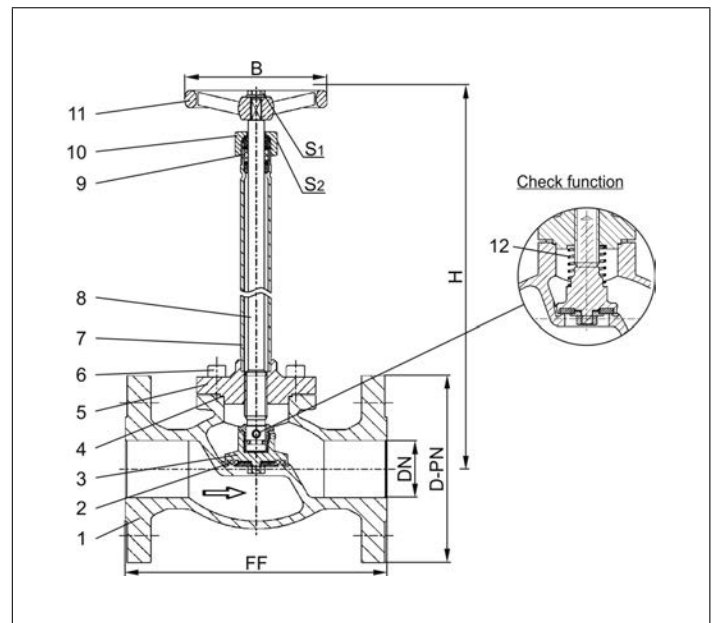

Type 03321 - Standard design	Technical data									
	DN	25	40	50	65	80	100	125	150	
Nominal size	.X.	0250	0400	0500	0650	0800	1000	1250	1500	
Dimension code - Flange EN 1092-1 PN40	D-PN	115	150	165	185	200	235	250	285	
Flange-Ø	FF	160	200	230	290	310	350	390	510	
Face-to-face dimension	H	270 mm or 370 mm						400	400	460
Height	B	100	125	125	200	250	315	315	360	
Handwheel-Ø	S ₁	10	13	13	13	13	13	13	19	
Wrench size across flats	S ₂	30	36	36	36	36	41	41	41	
Weight	ca. kg	4.9	9.7	13.3	21.1	28.0	43.2	56.0	68.5	
Kvs-Value	m ³ /h	11.5	22.6	37.1	71.1	104.0	170.0	170.0	350.0	
Cv-Value	gal/min	13.4	26.3	43.2	82.7	120.9	195.2	195.2	401.8	

Dimensions in mm.

Globe Valves

Type 03321 - Globe Valve, DIN EN Flanges



Cryogenic-Globe and Globe/Check Valves, PN40

Stainless steel body and bronze topwork,
 "live loaded" gland packing
 "cleaned and degreased for oxygen service"

Part No. 03321.X.0012 (H = 270mm)

Part No. 03321.X.0022 (H = 370mm)

Part No. 03321.X.5012 (H = 270mm) Globe/Check Valve

Part No. 03321.X.5022 (H = 370mm) Globe/Check Valve

Flanged connection acc. to DIN EN 1092-1 PN40

Available options - on request only:

- Extension H up to 900mm
- Valve with control disc (tapered design)
- Nominal sizes DN15, DN20 and DN150 with welded flange



Applications:

Approved for air gases, vapours and cryogenic liquefied gases incl. LNG.

Working temperature: -196°C / -321°F (77K) up to +120°C / +248°F (393K)

Materials	DIN EN	ASTM
1 Body	1.4308	A 351 CF8
2 Valve seal up to DN50	PTFE / Carbon filled (25%)	
2a Valve seal from DN65	PTFE	
3 Disc	CW614N	B 283 UNS C38500
4 Bonnet gasket	PTFE	
5 Headpiece	CC493K	B 505 UNS C93200
6 Bolts	1.4301/A2	A 194 B8
7 Elongation tube	1.4541	A 213 TP 321
8 Stem	1.4301	A 276 Grade 304
9 Gland packing	Graphite / PTFE	
10 Gland nut	CW614N	B 283 UNS C38500
11 Handwheel	Aluminium alloy	
12 Spring	CW452K	B 159 UNS C51900

Standard marking acc. to Pressure Equipment Directive 97/23/EC (PED).

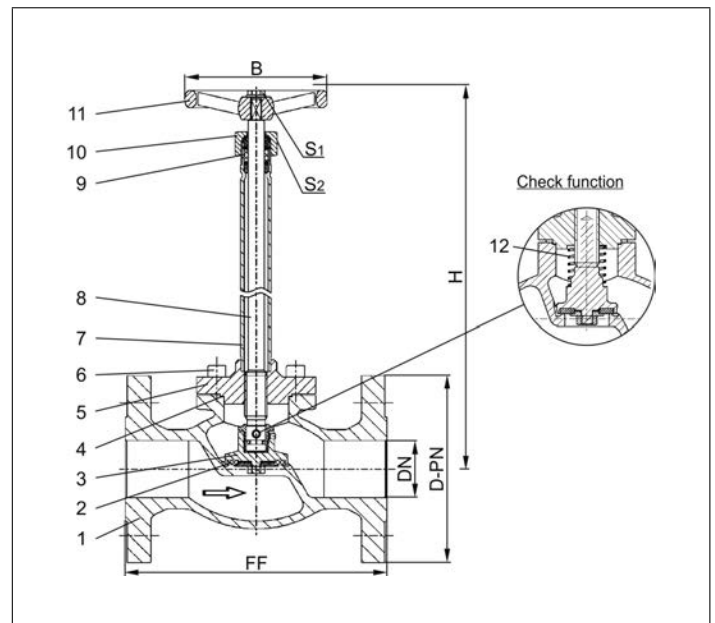

Type 03321 - Standard design	Technical data							
	DN	25	40	50	65	80	100	
Nominal size	.X.	0250	0400	0500	0650	0800	1000	
Dimension code - Flange EN 1092-1 PN40	D-PN	115	150	165	185	200	235	
Flange-Ø	FF	160	200	230	290	310	350	
Face-to-face dimension	H	270 mm or 370 mm						400
Height	B	100	125	125	200	250	315	
Handwheel-Ø	S ₁	10	13	13	13	13	13	
Wrench size across flats	S ₂	30	36	36	36	36	41	
Wrench size across flats	ca. kg	4.9	9.7	13.3	21.1	28.0	43.2	
Weight	m ³ /h	11.5	22.6	37.1	71.1	104.0	170.0	
Kvs-Value	gal/min	13.4	26.3	43.2	82.7	120.9	195.2	
Cv-Value								

Dimensions in mm.

Globe Valves

Type 03321 - Globe Valve, ANSI Flanges



Cryogenic-Globe and Globe/Check Valves, class 300

Stainless steel body and bronze topwork,
 "live loaded" gland packing
 "cleaned and degreased for oxygen service"

Part No. 03321.X.0013 (H = 270mm)
Part No. 03321.X.0023 (H = 370mm)
Part No. 03321.X.5013 (H = 270mm) Globe/Check Valve
Part No. 03321.X.5023 (H = 370mm) Globe/Check Valve
 Flanged connection acc. to ANSI B16.5 class 300

Available options - on request only:

- Extension H up to 900mm
- Valve with control disc (tapered design)
- Nominal sizes DN15, DN20 and DN150 with welded flange



Applications:

Approved for air gases, vapours and cryogenic liquefied gases incl. LNG.
 Working temperature: -196°C / -321°F (77K) up to +120°C / +248°F (393K)

Materials	DIN EN	ASTM
1 Body	1.4308	A 351 CF8
2 Valve seal up to DN50	PTFE / Carbon filled (25%)	
2a Valve seal from DN65	PTFE	
3 Disc	CW614N	B 283 UNS C38500
4 Bonnet gasket	PTFE	
5 Headpiece	CC493K	B 505 UNS C93200
6 Bolts	1.4301/A2	A 194 B8
7 Elongation tube	1.4541	A 213 TP 321
8 Stem	1.4301	A 276 Grade 304
9 Gland packing	Graphite / PTFE	
10 Gland nut	CW614N	B 283 UNS C38500
11 Handwheel	Aluminium alloy	
12 Spring	CW452K	B 159 UNS C51900

Standard marking acc. to Pressure Equipment Directive 97/23/EC (PED).

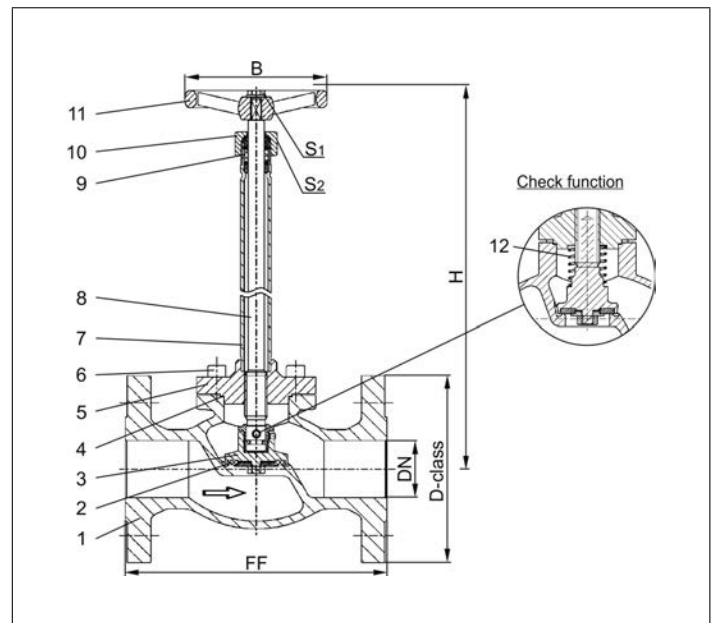

Type 03321 - Standard design	Technical data						
Nominal size	DN	25	40	50	65	80	100
Dimension code - Flange ANSI B16.5 class 300	.X.	1000	1400	2000	2400	3000	4000
Flange-Ø	D-class	123.9	155.4	165	190.5	209.5	254
Face-to-face dimension	FF	160	200	230	290	310	350
Height	H	270 mm or 370 mm					400
Handwheel-Ø	B	100	125	125	200	250	315
Wrench size across flats	S ₁	10	13	13	13	13	13
Wrench size across flats	S ₂	30	36	36	36	36	41
Weight	ca. kg	4.9	9.7	13.3	21.1	28.0	43.2
Kvs-Value	m ³ /h	11.5	22.6	37.1	71.1	104.0	170.0
Cv-Value	gal/min	13.4	26.3	43.2	82.7	120.9	195.2

Dimensions in mm.

Type 01341 - Globe Valve

Cryogenic-Globe and Globe/Check Valves, PN50 (DN100/150=PN40)

Stainless steel body and topwork,
 "live loaded" gland packing
 "cleaned and degreased for oxygen service"

Part No. 01341.X.001* (H = 270mm)

Part No. 01341.X.002* (H = 370mm)

Part No. 01341.X.501* (H = 270mm) Globe/Check Valve

Part No. 01341.X.502* (H = 370mm) Globe/Check Valve

*Butt weld connection for stainless steel pipes acc. to ISO 1127 or ASTM A312

Part No. 01341.X.0014 (H = 270mm)

Part No. 01341.X.0024 (H = 370mm)

Part No. 01341.X.5014 (H = 270mm) Globe/Check Valve

Part No. 01341.X.5024 (H = 370mm) Globe/Check Valve

Socket weld connection for stainless steel pipes acc. to ISO 1127 or ASTM A312

Available options - on request only:

- Welded stainless steel stubs acc. to ISO 1127 or ASTM A312 - length FF + 200mm
- Extension H up to 900mm
- Valve with control disc (tapered design)

Applications:

Approved for air gases, vapours and cryogenic liquefied gases incl. LNG.

Working temperature: -196°C / -321°F (77K) up to +120°C / +248°F (393K)



Materials	DIN EN	ASTM
1 Body	1.4308	A 351 CF8
2 Valve seal up to DN50	PTFE / Carbon filled (25%)	
2a Valve seal from DN65	PTFE	
3 Disc	1.4301	A 276 Grade 304
4 Bonnet gasket	PTFE	
5 Headpiece	1.4301 / 1.4308	A 276 Grade 304 / A 351 CF8
6 Bolts	1.4301/A2	A 194 B8
7 Elongation tube	1.4541	A 213 TP 321
8 Stem	1.4301	A 276 Grade 304
9 Gland packing	Graphite / PTFE	
10 Gland nut	1.4305	A 276 Grade 303
11 Handwheel	Aluminium alloy	
12 Spring	1.4310	A 313 Grade 301
13 Bush	CW452K	B 159 UNS C51900

Standard marking acc. to Pressure Equipment Directive 97/23/EC (PED).

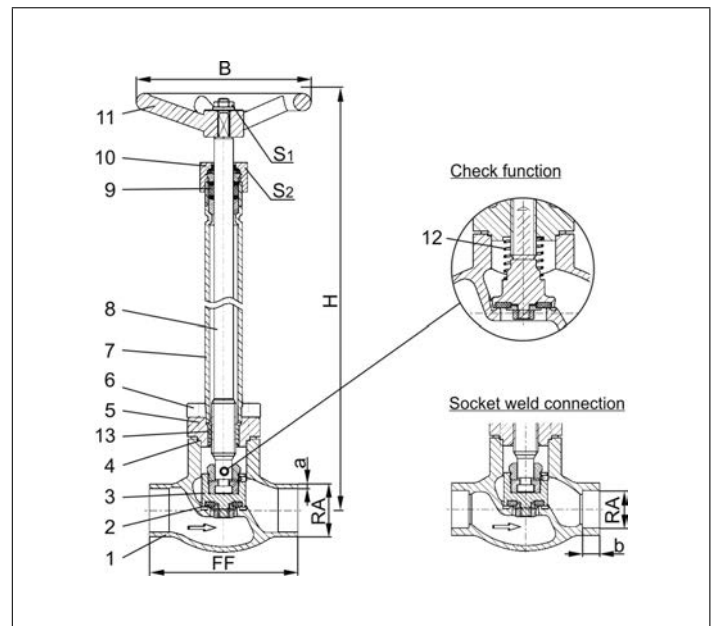

Type 01341 - Standard	Technical data													
	DN	10	15	15	20	25	32	40	40	50	65	80	100	150
Nominal size	.X.	1012	1517	1521	2026	2533	3238	4042	4048	5060	657x	8088	0114	0168
Dimension code														
Face-to-face dimension	FF	70	85	85	100	115	115	130	130	155	205	245	280	400
Height	H	270mm or 370mm												
Outside pipe-Ø ISO 1127	RA	12.0	17.2	21.3	26.9	33.7	38.0	42.4	48.3	60.3	76.1	88.9	114.3	168.3
Wall thickness pipe ISO 1127	a	1.0	1.6	2.0	2.0	2.0	2.0	2.0	2.0	2.0	2.6	3.2	6.0	7.1
Outside pipe-Ø ASTM A312	RA	13.72	17.15	21.34	26.67	33.40	-	42.16	48.26	60.33	73.03	88.90	114.3	168.3
Wall thickness pipe ASTM A312	a	dimensions acc. to S10 or S40												
Socket depth	b	6	10	10	13	13	-	13	13	16	16	16	20	20
Handwheel-Ø	B	100	100	100	100	100	125	125	125	125	200	250	315	360
Wrench size across flats	S ₁	10	10	10	10	10	13	13	13	13	13	13	13	19
Wrench size across flats	S ₂	30	30	30	30	30	36	36	36	36	36	36	41	41
Weight	ca. kg	1.4	1.65	1.7	2.1	2.4	3.3	4.7	4.7	7.2	12.7	17.0	24.5	54.0
Kvs-Value	m ³ /h	1.6	3.8	4.3	6.7	11.5	14.0	20.6	22.6	37.1	71.1	104.0	170.0	350.0
Cv-Value	gal/min	1.9	4.4	5.0	7.8	13.4	16.2	23.9	26.3	43.2	82.7	120.9	195.2	401.8

Dimensions in mm. Compliance of tightness requirements acc. to EN 1626 for DN150 up to 20 bar differential pressure. In the range of >20-40 bar, 350-700ml (1 bar, 20°C [68°F]) are reached.

Globe Valves

Type 01341 - Globe Valve



Cryogenic Globe Valves, DN200, PN25

Stainless steel body and topwork
"live loaded" gland packing

Part No. 01341.0219.001* (H=560)

Part No. 01341.0219.006* (H=1000)

*Butt weld connection for stainless steel pipes acc. to ISO 1127 or ASTM A312

Artikel-Nr. 01341.0219.00*4

Socket weld connection for stainless steel pipes acc. to ISO 1127 or ASTM A312

In flow direction, the valve with the nominal size DN200 is conform to tightness class L1 up to 12 bar maximum differential pressure acc. to DIN 12567 for LNG use. This standard can also be used for the tightness class of other cryogenic gases.

Available options - on request only

Applications:

Approved for air gases, vapours and cryogenic liquefied gases incl. LNG.

Working temperature: -196°C / -321°F (77K) up to +120°C / +248°F (393K)



Materials	DIN EN	ASTM
1 Body	1.4308	A 351 CF8
2 Valve seal	PTFE	
3 Disc	1.4301	A 276 Grade 304
4 Bonnet gasket	PTFE	
5 Headpiece	1.4301	A 276 Grade 304
6 Bolts	1.4301/A2	A 194 B8
7 Elongation tube	1.4541	A 213 TP 321
8 Stem	1.4301	A 276 Grade 304
9 Gland packing	Graphite / PTFE	
10 Gland nut	1.4305	A 276 Grade 303
11 Handwheel	Aluminium alloy	
13 Bush	CW452K	B 159 UNS C51900

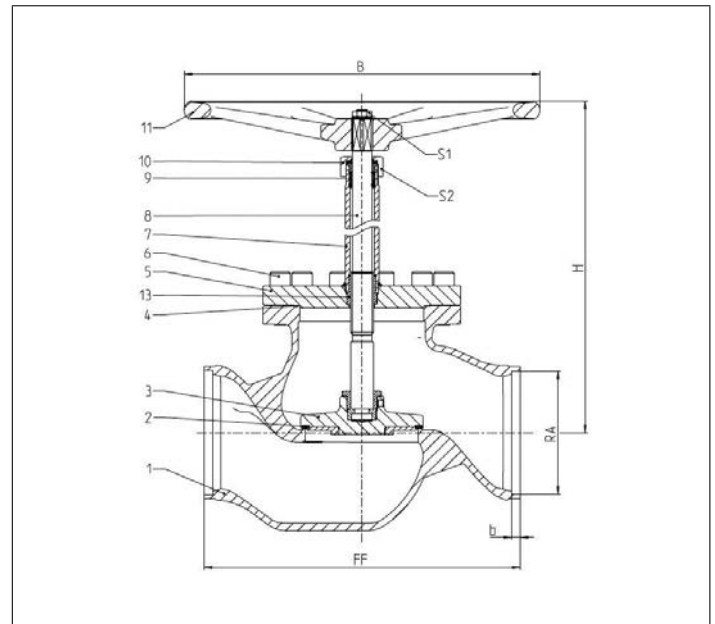

Standard marking acc. to Pressure Equipment Directive 97/23/EC (PED).



Type 01341 - Standard	Technical data	
Nominal size	DN	200
Dimension code	.X.	0219
Face-to-face dimension	FF	560
Height	H	1000
Outside pipe-Ø ISO 1127	RA	219.1
Wall thickness pipe ISO 1127	a	6.3
Outside pipe-Ø ASTM A312	RA	219.1
Wall thickness pipe ASTM A312	a	dimensions acc. to S10 or S40
Socket depth	b	15
Handwheel-Ø	B	630
Wrench size across flats	S ₁	30
Wrench size across flats	S ₂	65
Weight	ca. kg	135
Kvs-Value	m ³ /h	680
Cv-Value	gal/min	786

Dimensions in mm.

Globe Valves

Type 01345 - Globe Valve



Cryogenic-Globe and Globe/Check Valves, PN50

Stainless steel body and topwork,
 "live loaded" gland packing
 "cleaned and degreased for oxygen service"

- Part No. 01345.X.0011 (H = 270mm)**
- Part No. 01345.X.0021 (H = 370mm)**
- Part No. 01345.X.5011 (H = 270mm) Globe/Check Valve**
- Part No. 01345.X.5021 (H = 370mm) Globe/Check Valve**
- Female thread connection (G) acc. to ISO 228/1
- Part No. 01345.X.0016 (H = 270mm)**
- Part No. 01345.X.0026 (H = 370mm)**
- Part No. 01345.X.5016 (H = 270mm) Globe/Check Valve**
- Part No. 01345.X.5026 (H = 370mm) Globe/Check Valve**
- Female thread connection NPT acc. to ANSI B 1.20.1

Available options - on request only:

- Female thread connection (R) acc. to ISO 7-Rc
- Extension H up to 900mm
- Valve with control disc (tapered design)

Applications:

Approved for air gases, vapours and cryogenic liquefied gases incl. LNG.
 Working temperature: -196°C / -321°F (77K) up to +120°C / +248°F (393K)



Materials	DIN EN	ASTM
1 Body	1.4308	A 351 CF8
2 Valve seal	PTFE / Carbon filled (25%)	
3 Disc	1.4301	A 276 Grade 304
4 Bonnet gasket	PTFE	
5 Headpiece	1.4301 / 1.4308	A 276 Grade 304 / A 351 CF8
6 Bolts	1.4301/A2	A 194 B8
7 Elongation tube	1.4541	A 213 TP 321
8 Stem	1.4301	A 276 Grade 304
9 Gland packing	Graphite / PTFE	
10 Gland nut	1.4305	A 276 Grade 303
11 Handwheel	Aluminium alloy	
12 Spring	1.4310	A 313 Grade 301
13 Bush	CW452K	B 159 UNS C51900

Standard marking acc. to Pressure Equipment Directive 97/23/EC (PED).

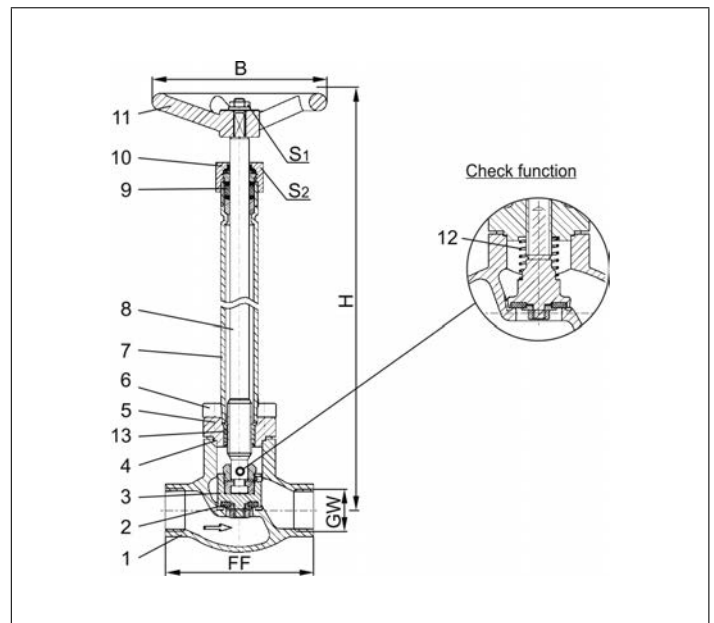

Type 01345 - Standard design	Technical data								
Nominal size	DN	10	10	15	20	25	40	40	50
Thread size	GW	1/4	3/8	1/2	3/4	1	1-1/4	1-1/2	2
Dimension code	.X.	0200	0300	0400	0600	1000	1200	1400	2000
Face-to-face dimension	FF	70	70	85	100	115	130	130	155
Height	H	270mm or 370mm							
Handwheel-Ø	B	100	100	100	100	100	125	125	125
Wrench size across flats	S ₁	10	10	10	10	10	13	13	13
Wrench size across flats	S ₂	30	30	30	30	30	36	36	36
Weight	ca. kg	1.4	1.4	1.7	2.1	2.4	4.7	4.7	7.2
Kvs-Value	m ³ /h	1.6	2.2	4.3	6.7	11.5	20.6	22.6	37.1
Cv-Value	gal/min	1.9	2.6	5.0	7.8	13.4	23.9	26.3	43.2

Dimensions in mm.

Globe Valves

Type 03341 - Globe Valve, DIN EN Flanges



Cryogenic-Globe and Globe/Check Valves, PN40

Stainless steel body and topwork,
 "live loaded" gland packing
 "cleaned and degreased for oxygen service"

- Part No. 03341.X.0012 (H = 270mm)**
 - Part No. 03341.X.0022 (H = 370mm)**
 - Part No. 03341.X.5012 (H = 270mm) Globe/Check Valve**
 - Part No. 03341.X.5022 (H = 370mm) Globe/Check Valve**
- Flanged connection acc. to DIN EN 1092-1 PN40

Available options - on request only:

- Extension H up to 900mm
- Valve with control disc (tapered design)
- Nominal sizes DN15, DN20 and DN150 with welded flange



Applications:

Approved for air gases, vapours and cryogenic liquefied gases incl. LNG.
 Working temperature: -196°C / -321°F (77K) up to +120°C / +248°F (393K)

Materials	DIN EN	ASTM
1 Body	1.4308	A 351 CF8
2 Valve seal up to DN50	PTFE / Carbon filled (25%)	
2a Valve seal from DN65	PTFE	
3 Disc	1.4301	A 276 Grade 304
4 Bonnet gasket	PTFE	
5 Headpiece	1.4301 / 1.4308	A 276 Grade 304 / A 351 CF8
6 Bolts	1.4301/A2	A 194 B8
7 Elongation tube	1.4541	A 213 TP 321
8 Stem	1.4301	A 276 Grade 304
9 Gland packing	Graphite / PTFE	
10 Gland nut	1.4305	A 276 Grade 303
11 Handwheel	Aluminium alloy	
12 Spring	1.4310	A 313 Grade 301
13 Bush	CW452K	B 159 UNS C51900

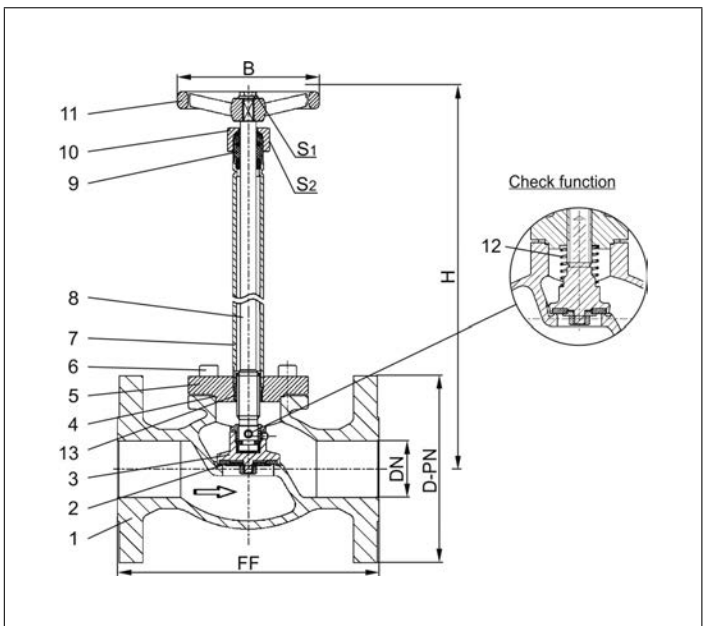

Standard marking acc. to Pressure Equipment Directive 97/23/EC (PED).



Type 03341 - Standard design	Technical data						
	DN	25	40	50	65	80	100
Nominal size	.X.	0250	0400	0500	0650	0800	1000
Dimension code - Flange EN 1092-1 PN40	D-PN	115	150	165	185	200	235
Flange-Ø	FF	160	200	230	290	310	350
Face-to-face dimension	H	270 mm or 370 mm					400
Height	B	100	125	125	200	250	315
Handwheel-Ø	S ₁	10	13	13	13	13	13
Wrench size across flats	S ₂	30	36	36	36	36	41
Weight	ca. kg	4.9	9.7	13.3	21.1	28.0	43.2
Kvs-Value	m ³ /h	11.5	22.6	37.1	71.1	104.0	170.0
Cv-Value	gal/min	13.4	26.3	43.2	82.7	120.9	195.2

Dimensions in mm.

Globe Valves

Type 03341 - Globe Valve, ANSI Flanges



Cryogenic-Globe and Globe/Check Valves, class 300

Stainless steel body and topwork,
 "live loaded" gland packing
 "cleaned and degreased for oxygen service"

Part No. 03341.X.0013 (H = 270mm)
Part No. 03341.X.0023 (H = 370mm)
Part No. 03341.X.5013 (H = 270mm) Globe/Check Valve
Part No. 03341.X.5023 (H = 370mm) Globe/Check Valve
 Flanged connection acc. to ANSI B16.5 class 300

Available options - on request only:

- Extension H up to 900mm
- Valve with control disc (tapered design)
- Nominal sizes DN15, DN20 and DN150 with welded flange



Applications:

Approved for air gases, vapours and cryogenic liquefied gases incl. LNG.
 Working temperature: -196°C / -321°F (77K) up to +120°C / +248°F (393K)

Materials	DIN EN	ASTM
1 Body	1.4308	A 351 CF8
2 Valve seal up to DN50	PTFE / Carbon filled (25%)	
2a Valve seal from DN65	PTFE	
3 Disc	1.4301	A 276 Grade 304
4 Bonnet gasket	PTFE	
5 Headpiece	1.4301 / 1.4308	A 276 Grade 304 / A 351 CF8
6 Bolts	1.4301/A2	A 194 B8
7 Elongation tube	1.4541	A 213 TP 321
8 Stem	1.4301	A 276 Grade 304
9 Gland packing	Graphite / PTFE	
10 Gland nut	1.4305	A 276 Grade 303
11 Handwheel	Aluminium alloy	
12 Spring	1.4310	A 313 Grade 301
13 Bush	CW452K	B 159 UNS C51900

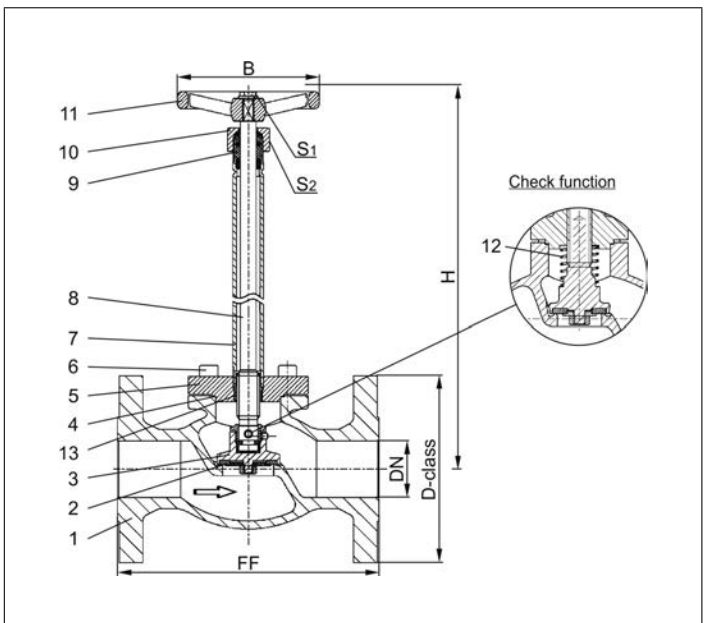

Standard marking acc. to Pressure Equipment Directive 97/23/EC (PED).



Type 03341 - Standard design	Technical data						
	DN	25	40	50	65	80	100
Nominal size	.X.	1000	1400	2000	2400	3000	4000
Dimension code - Flange ANSI B16.5 class 300	D-class	123.9	155.4	165	190.5	209.5	254
Flange-Ø	FF	160	200	230	290	310	350
Face-to-face dimension	H	270 mm or 370 mm					400
Height	B	100	125	125	200	250	315
Handwheel-Ø	S ₁	10	13	13	13	13	13
Wrench size across flats	S ₂	30	36	36	36	36	41
Weight	ca. kg	4.9	9.7	13.3	21.1	28.0	43.2
Kvs-Value	m ³ /h	11.5	22.6	37.1	71.1	104.0	170.0
Cv-Value	gal/min	13.4	26.3	43.2	82.7	120.9	195.2

Dimensions in mm.

Globe Valves

Type 01252 - Bellow Sealed Globe Valve



Cryogenic-Bellow Sealed Globe Valve, PN50

Stainless steel body and topwork,
 "live loaded" gland packing
 "cleaned and degreased for oxygen service"

Part No. 01252.X.002*

* Butt weld connection for stainless steel pipes acc. to ISO 1127 or ASTM A312

Part No. 01252.X.0024

Socket weld connection for stainless steel pipes acc. to ISO 1127 or ASTM A312

Available options - on request only:

- Welded stainless steel stubs acc. to ISO 1127 or ASTM A312 - length FF + 200mm
- Extension H up to 900mm
- Valve with control disc (tapered design)



Applications:

Approved for air gases, vapours and cryogenic liquefied gases incl. LNG.
 Working temperature: -196°C / -321°F (77K) up to +120°C / +248°F (393K)
 Leak rate: 10⁻⁶ mbar ltr / sec outside
 10⁻⁴ mbar ltr / sec seat

Materials	DIN EN	ASTM
1 Body	1.4308	A 351 CF8
2 Valve seal	PTFE / Carbon filled (25%)	
3 Disc	1.4301	A 276 Grade 304
4 Bonnet gasket	PTFE	
5 Headpiece	1.4301	A 276 Grade 304
6 Bellow stem	1.4571	A 276 Grade 316Ti
7 Bolts	1.4301/A2	A 194 B8
8 Bellow	1.4571	A 276 Grade 316Ti
9 Elongation tube	1.4541	A 213 TP 321
10 Upper part	1.4301	A 276 Grade 304
11 Bush	CW452K	B 159 UNS C51900
12 Stem	1.4301	A 276 Grade 304
13 Gland packing	Graphite / PTFE	
14 Gland nut	1.4305	A 276 Grade 303
15 Handwheel	Aluminium alloy	

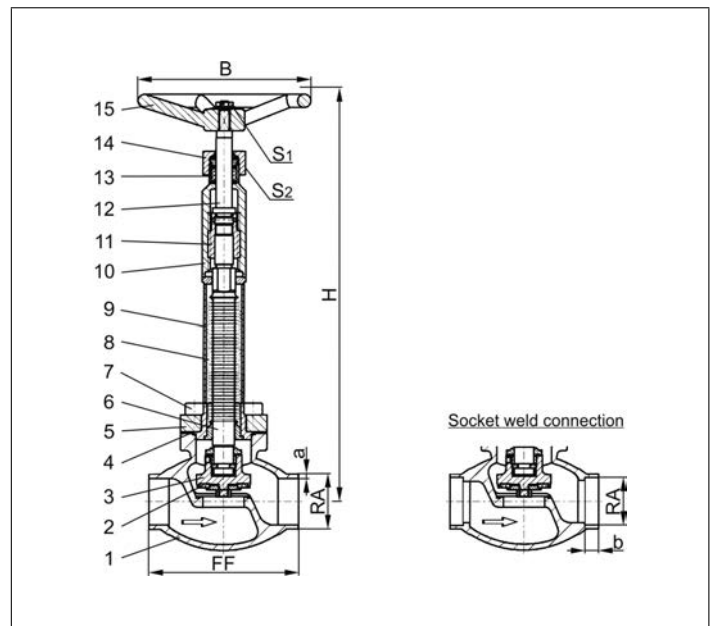

Standard marking acc. to Pressure Equipment Directive 97/23/EC (PED).



Type 01252 - Standard design	Technical data										
Nominal size	DN	10	15	15	20	25	32	40	40	50	
Dimension code	.X.	1012	1517	1521	2026	2533	3238	4042	4048	5060	
Face-to-face dimension	FF	70	85	85	100	115	115	130	130	155	
Height	H	380	380	380	380	380	380	380	380	380	
Outside pipe-Ø ISO 1127	RA	12.0	17.2	21.3	26.9	33.7	38.0	42.4	48.3	60.3	
Wall thickness pipe ISO 1127	a	1.0	1.6	2.0	2.0	2.0	2.0	2.0	2.0	2.0	
Outside pipe-Ø ASTM A312	RA	13.72	17.15	21.34	26.67	33.40	-	42.16	48.26	60.33	
Wall thickness pipe ASTM A312	a	dimensions acc. to S10 or S40									
Socket depth	b	6	10	10	13	13	-	13	13	16	
Handwheel-Ø	B	150	150	150	150	150	150	150	150	150	
Wrench size across flats	S ₁	10	10	10	10	10	13	13	13	13	
Wrench size across flats	S ₂	30	30	30	30	30	36	36	36	36	
Weight	ca. kg	1.6	1.85	1.9	2.3	2.7	3.6	5.1	5.1	7.7	
Kvs-Value	m ³ /h	1.6	2.8	4.3	6.7	11.5	14.0	20.6	22.6	37.1	
Cv-Value	gal/min	1.9	3.3	5.0	7.8	13.4	16.2	26.3	26.3	43.2	

Dimensions in mm.

Globe Valves

Type 03252 - Bellow Sealed Globe Valve



Cryogenic-Bellow Sealed Globe Valve, PN40

Stainless steel body and topwork,
 "live loaded" gland packing
 "cleaned and degreased for oxygen service"

Part No. 03252.X.0022

Flanged connection acc. to DIN EN 1092-1 PN40

Available options - on request only:

- Extension H up to 900mm
- Valve with control disc (tapered design)
- Nominal sizes DN15, DN20 and DN150 with welded flange



Applications:

Approved for air gases, vapours and cryogenic liquefied gases incl. LNG.
 Working temperature: -196°C / -321°F (77K) up to +120°C / +248°F (393K)
 Leak rate: 10⁻⁶ mbar ltr / sec outside, 10⁻⁴ mbar ltr / sec seat

Materials	DIN EN	ASTM
1 Body	1.4308	A 351 CF8
2 Valve seal	PTFE / Carbon filled (25%)	
3 Disc	1.4301	A 276 Grade 304
4 Bonnet gasket	PTFE	
5 Headpiece	1.4301	A 276 Grade 304
6 Bellow stem	1.4571	A 276 Grade 316Ti
7 Bolts	1.4301/A2	A 194 B8
8 Bellow	1.4571	A 276 Grade 316Ti
9 Elongation tube	1.4541	A 213 TP 321
10 Upper part	1.4301	A 276 Grade 304
11 Bush	CW452K	B 159 UNS C51900
12 Stem	1.4301	A 276 Grade 304
13 Gland packing	Graphite / PTFE	
14 Gland nut	1.4305	A 276 Grade 303
15 Handwheel	Aluminium alloy	

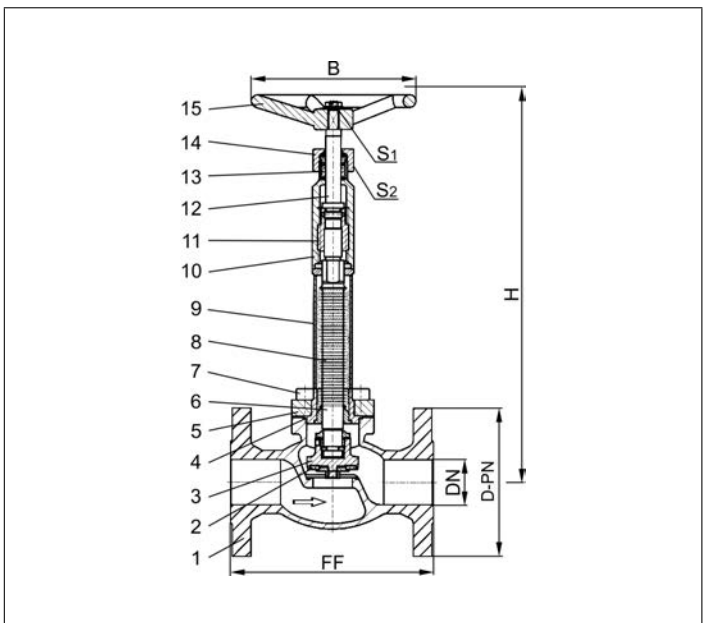

Standard marking acc. to Pressure Equipment Directive 97/23/EC (PED).



Type 03252 - Standard design	Technical data			
Nominal size	DN	25	40	50
Dimension code - Flange EN 1092-1 PN40	.X.	0250	0400	0500
Flange-Ø	D-PN	115	150	165
Face-to-face dimension	FF	160	200	230
Height	H	380	380	380
Handwheel-Ø	B	150	150	150
Wrench size across flats	S ₁	10	13	13
Wrench size across flats	S ₂	30	36	36
Weight	ca. kg	5.2	10.1	13.8
Kvs-Value	m ³ /h	11.5	22.6	37.1
Cv-Value	gal/min	13.4	26.3	43.2

Dimensions in mm.

Globe Valves

Type 03252 - Bellow Sealed Globe Valve



Cryogenic-Bellow Sealed Globe Valve, class 300

Stainless steel body and topwork,
 "live loaded" gland packing
 "cleaned and degreased for oxygen service"

Part No. 03252.X.0023

Flanged connection acc. to ANSI B16.5 class 300

Available options - on request only:

- Extension H up to 900mm
- Valve with control disc (tapered design)
- Nominal sizes DN15, DN20 and DN150 with welded flange



Applications:

Approved for air gases, vapours and cryogenic liquefied gases incl. LNG.
 Working temperature: -196°C / -321°F (77K) up to +120°C / +248°F (393K)
 Leak rate: 10^{-6} mbar ltr / sec outside, 10^{-4} mbar ltr / sec seat

Materials	DIN EN	ASTM
1 Body	1.4308	A 351 CF8
2 Valve seal	PTFE / Carbon filled (25%)	
3 Disc	1.4301	A 276 Grade 304
4 Bonnet gasket	PTFE	
5 Headpiece	1.4301	A 276 Grade 304
6 Bellow stem	1.4571	A 276 Grade 316Ti
7 Boltshrauben	1.4301/A2	A 194 B8
8 Bellow	1.4571	A 276 Grade 316Ti
9 Elongation tube	1.4541	A 213 TP 321
10 Upper part	1.4301	A 276 Grade 304
11 Bush	CW452K	B 159 UNS C51900
12 Stem	1.4301	A 276 Grade 304
13 Gland packing	Graphite / PTFE	
14 Gland nut	1.4305	A 276 Grade 303
15 Handwheel	Aluminium alloy	

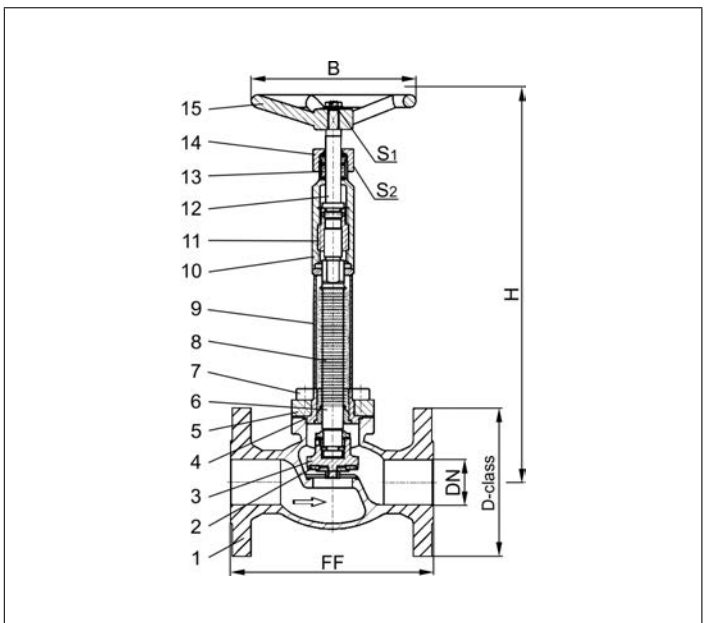

Standard marking acc. to Pressure Equipment Directive 97/23/EC (PED).



Type 03252 - Standard design	Technical data			
Nominal size	DN	25	40	50
Dimension code - Flange ANSI B16.5 class 300	.X.	1000	1400	2000
Flange-Ø	D-class	123.9	155.4	165
Face-to-face dimension	FF	160	200	230
Height	H	380	380	380
Handwheel-Ø	B	150	150	150
Wrench size across flats	S ₁	10	13	13
Wrench size across flats	S ₂	30	36	36
Weight	ca. kg	5.2	10.1	13.8
Kvs-Value	m ³ /h	11.5	22.6	37.1
Cv-Value	gal/min	13.4	26.3	43.2

Dimensions in mm.

Globe Valves

Type 01420 - Top-Entry-Valve



Cryogenic-Globe Valves, PN50

Stainless steel body and topwork,
 "live loaded" gland packing
 "cleaned and degreased for oxygen service"

Part No. 01420.X.0781

Part No. 01420.X.5781 Globe/Check Valve

Butt weld connection for stainless steel pipes acc. to ASTM A312

Available options - on request only:

- Extension H and E acc. to customer specification



Applications:

Approved for air gases, vapours and cryogenic liquefied gases incl. LNG.

Working temperature: -196°C / -321°F (77K) up to +120°C / +248°F (393K)

Materials	DIN EN	ASTM
1 Body	1.4308	A 351 CF8
2 Valve seal	PTFE / Carbon filled (25%)	
3 Disc	1.4301	A 276 Grade 304
4 Guide bush	CC493K	B 505 UNS C93200
5 Stem	1.4301	A 276 Grade 304
6 Elongation tube	1.4541	A 213 TP 321
7 Elongation tube	1.4541	A 213 TP 321
8 Cold box feature	1.4541	A 213 TP 321
9 Headpiece flange	1.4301	A 276 Grade 304
10 Headpiece	1.4301	A 276 Grade 304
11 Bolts	1.4301/A2	A 194 B8
12 Gland packing	Graphite / PTFE	
13 Gland nut	1.4305	A 276 Grade 303
14 Handwheel	Aluminium alloy	

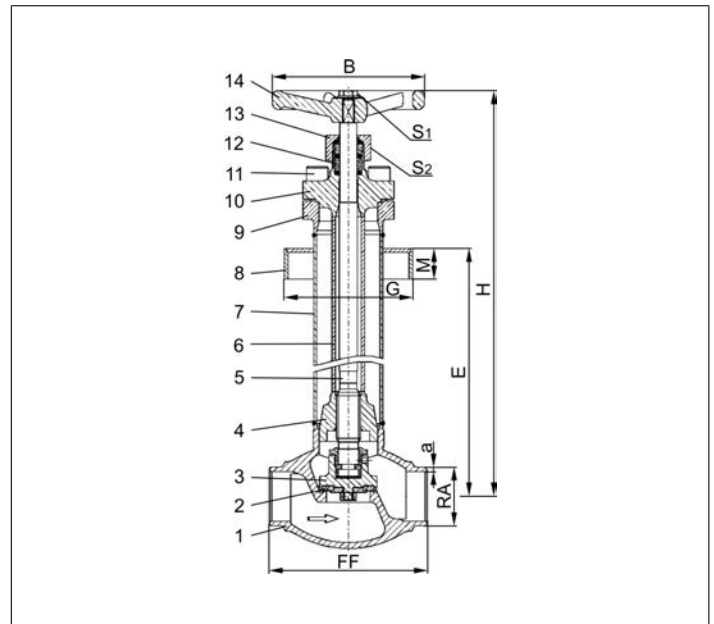

Standard marking acc. to Pressure Equipment Directive 97/23/EC (PED).



Type 01420 - Standard design	Technical data					
Nominal size	DN	15	20	25	40	50
Dimension code	.X.	1521	2026	2533	4048	5060
Face-to-face dimension	FF	85	100	115	130	155
Height	H	690	690	690	690	760
Handwheel-Ø	B	100	100	100	200	200
Outside pipe -Ø ASTM A312	RA	21.34	26.67	33.40	48.26	60.33
Wall thickness pipe ASTM A312	a	dimensions acc. to S10 or S40				
Length	E	540	540	540	540	610
Length	G	according to customer specification				
Length	M	according to customer specification				
Wrench size across flats	S ₁	10	10	10	13	13
Wrench size across flats	S ₂	30	30	30	36	36
Weight	ca. kg	3.0	3.5	4.0	8.5	11.5
Kvs-Value	m ³ /h	4.3	6.7	11.5	22.6	37.1
Cv-Value	gal/min	5.0	7.8	13.4	26.3	43.2

Dimensions in mm.

Globe Valves

Type 1114 - Globe Valve



Cryogenic-Globe Valves, PN50

Stainless steel body and topwork,
 Inner parts made of brass
 "live loaded" gland packing
 "cleaned and degreased for oxygen service"

Available options - on request only:

- Welded stainless steel stubs acc. to ISO 1127 or ASTM A312 - length FF + 200mm
- Extension H up to 900mm
- Valve with control disc (tapered design)
- Disc with PCTFE seal
- Further connection types



Applications:

Approved for air gases, vapours and cryogenic liquefied gases incl. LNG.
 Working temperature: -196°C / -321°F (77K) up to +120°C / +248°F (393K)
 Recommended working temperature (for versions without extension):
 -60°C / -76°F (213K) up to +120°C / +248°F (393K)

Materials	DIN EN	ASTM
1 Body	1.4308	A 351 CF8
2 Valve seal	PTFE / Carbon filled (25%)	
3 Disc up to DN40	CW614N	B 283 UNS C38500
3a Disc from DN50	CW509L	B 111 UNS C28000
4 Bonnet gasket	PTFE	
5 Headpiece	1.4308	A 351 CF8
6 Bolts	1.4301/A2	A 320 B8
7 Elongation tube	1.4541	A 213 TP 321
8 Stem	1.4301	A 479 Grade 304
9 Gland packing	Graphite / PTFE	
10 Gland nut	CW614N	B 283 UNS C38500
11 Handwheel	Aluminium alloy	
12 Spring	CW452K	B 159 UNS C51900
13 Bush	CW452K	B 159 UNS C51900
14 Sleeve	CW614N	B 283 UNS C38500

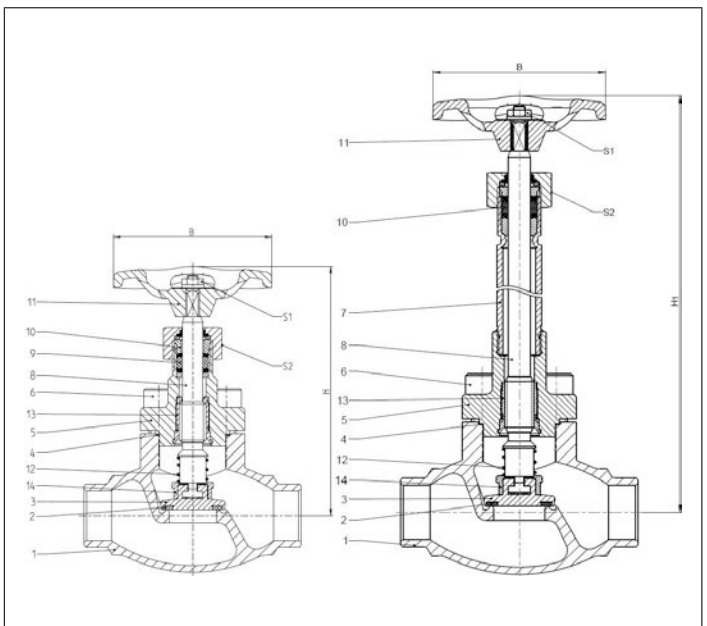

Standard marking acc. to Pressure Equipment Directive 97/23/EC (PED).



Technical Data - standard version

Nominal size [DN]	Height (H) [mm]	Height (H ₁) [mm]	Handwheel-Ø (B) [mm]	Wrench size across flats (S ₁) [mm]	Wrench size across flats (S ₂) [mm]
10	140	270/370	100	10	27
15	140	270/370	100	10	27
20	140	270/370	100	10	27
25	140	270/370	100	10	27
40	175	270/370	125	13	32
50	200	270/370	125	13	32

Globe Valves

Type 1114 - Globe Valve



Connection types

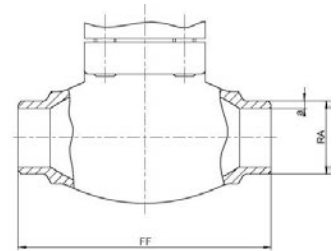

Butt weld connection acc. to · ISO 1127

DN	Face-to-face dim. (FF) [mm]	Outside pipe-Ø (RA) [mm]	ISO Wall thickness pipe ISO (a) [mm]	Kvs-value [m ³ /h]	Cv-value [gal/min]	Weight, w.e.* [kg]	Part No.
10	70	13.5	2.3	1.6	1.9	0.85	1114.0135023.X0
15	85	17.2	1.6	3.8	4.4	0.96	1114.0172016.X0
15	85	21.3	2.0	4.3	5.0	0.98	1114.0213020.X0
20	100	26.9	2.0	6.7	7.8	1.43	1114.0269020.X0
25	115	33.7	2.6	11.5	13.4	1.92	1114.0337026.X0
40	130	42.4	2.6	20.6	23.9	3.49	1114.0424026.X0
40	130	48.3	2.6	22.6	26.3	3.36	1114.0483026.X0
50	155	60.3	2.6	37.1	43.2	4.94	1114.0603026.X0

Butt weld connection acc. to · ASTM A312

DN	Face-to-face dim. (FF) [mm]	Outside pipe-Ø (RA) [mm]	ASTM Wall thickness pipe ASTM (a) [mm]	Kvs-value [m ³ /h]	Cv-value [gal/min]	Weight, w.e.* [kg]	Part No.
10	70	13.7	2.3	1.6	1.9	0.85	1114.0137S40.X0
15	85	17.1	1.6	3.8	4.4	0.96	1114.0171S10.X0
15	85	21.3	2.1	4.3	5.0	0.98	1114.0213S10.X0
20	100	26.6	2.1	6.7	7.8	1.43	1114.0266S10.X0
25	115	33.4	2.7	11.5	13.4	1.92	1114.0334S10.X0
40	130	42.4	2.7	20.6	23.9	3.49	1114.0424S10.X0
40	130	48.2	2.7	22.6	26.3	3.36	1114.0482S10.X0
50	155	60.3	2.7	37.1	43.2	4.94	1114.0603S10.X0

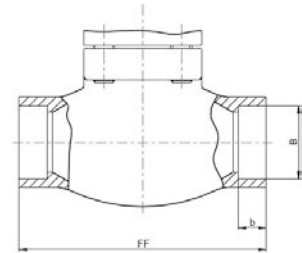

Socket weld connection acc. to · ISO 1127

· ASTM A312

DN	Face-to-face dim. (FF) [mm]	Socket depth (b) [mm]	Socket diameter (B) [mm]	Kvs-value [m ³ /h]	Cv-value [gal/min]	Weight, w.e.* [kg]	Part No.
10	70	6.0	14.1	1.6	1.9	0.85	1114.0141000.X0
15	85	8.0	17.5	3.8	4.4	0.96	1114.0175000.X0
15	85	10.0	21.5	4.3	5.0	0.98	1114.0215000.X0
20	100	13.0	27.5	6.7	7.8	1.43	1114.0275000.X0
25	115	13.0	34.1	11.5	13.4	1.92	1114.0341000.X0
40	130	13.0	42.8	20.6	23.9	3.49	1114.0428000.X0
40	130	13.0	48.65	22.6	26.3	3.36	1114.0486000.X0
50	155	16.0	61.1	37.1	43.2	4.94	1114.0611000.X0

* w.e. = without extension

X = 0 (without extension), 1 (with 270mm extension), 2 (with 370mm extension)

Globe Valves

Type 1114 - Globe Valve



Connection types

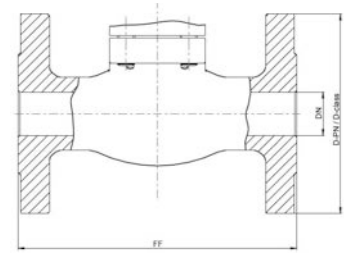

Flanged connection acc. to

- DIN EN 1092-1 PN40
- ANSI B16.5 class 300

DN / NPS	Face-to-face dim. (FF) [mm]	Flange-Ø (D-PN) [mm]	Flange-Ø (D-class) [mm]	Kvs-value [m ³ /h]	Cv-value [gal/min]	Weight, w.e.* [kg]	Part No. DIN EN	Part No. ANSI
15 / 1/2***	161	95	95	4.3	5.0	2.86	1114.015P040.X0	1114.015C300.X0
20 / 3/4***	181	105	115	6.7	7.8	3.72	1114.020P040.X0	1114.020C300.X0
25 / 1"	160	115	125	11.5	13.4	4.60	1114.025P040.X0	1114.025C300.X0
40 / 1-1/2"	200	150	155	22.6	26.3	8.62	1114.040P040.X0	1114.040C300.X0
50 / 2"	230	165	165	37.1	43.2	12.48	1114.050P040.X0	1114.050C300.X0

** welded version

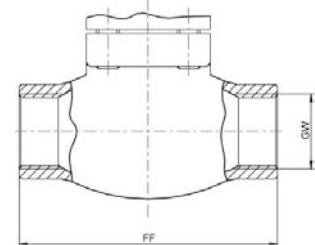

Female thread connection acc. to

- ISO 228/1 (G)
- NPT acc. to ANSI B 1.20.1 (NPT)

DN	Face-to-face dim. (FF) [mm]	Thread size (GW)	Kvs-value [m ³ /h]	Cv-value [gal/min]	Weight, w.e.* [kg]	Part No. G-thread	Part No. NPT-thread
10	70	1/4"	1.6	1.9	0.85	1114.FG02000.X0	1114.FN02000.X0
10	70	3/8"	2.2	2.6	0.85	1114.FG03000.X0	1114.FN03000.X0
15	85	1/2"	4.3	5.0	0.98	1114.FG04000.X0	1114.FN04000.X0
20	100	3/4"	6.7	7.8	1.43	1114.FG06000.X0	1114.FN06000.X0
25	115	1"	11.5	13.4	1.92	1114.FG10000.X0	1114.FN10000.X0
40	130	1-1/4"	20.6	23.9	3.49	1114.FG12000.X0	1114.FN12000.X0
40	130	1-1/2"	22.6	26.3	3.36	1114.FG14000.X0	1114.FN14000.X0
50	155	2"	37.1	43.2	4.94	1114.FG20000.X0	1114.FN20000.X0

Female thread connection acc. to

- ISO 7-1 (Rc or Rp)

DN	Face-to-face dim. (FF) [mm]	Thread size (GW)	Kvs-value [m ³ /h]	Cv-value [gal/min]	Weight, w.e.* [kg]	Part No. Rc-thread	Part No. Rp-thread
10	70	1/4"	1.6	1.9	0.85	1114.FR02000.X0	1114.FP02000.X0
10	70	3/8"	2.2	2.6	0.85	1114.FR03000.X0	1114.FP03000.X0
15	85	1/2"	4.3	5.0	0.98	1114.FR04000.X0	1114.FP04000.X0
20	100	3/4"	6.7	7.8	1.43	1114.FR06000.X0	1114.FP06000.X0
25	115	1"	11.5	13.4	1.92	1114.FR10000.X0	1114.FP10000.X0
40	130	1-1/4"	20.6	23.9	3.49	1114.FR12000.X0	1114.FP12000.X0
40	130	1-1/2"	22.6	26.3	3.36	1114.FR14000.X0	1114.FP14000.X0
50	155	2"	37.1	43.2	4.94	1114.FR20000.X0	1114.FP20000.X0

* w.e. = without extension

X = 0 (without extension), 1 (with 270mm extension), 2 (with 370mm extension)

Globe Valves

Type 1116 - Globe Valve



Cryogenic-Globe Valves, PN50

Stainless steel body and topwork,
 Inner parts made of stainless steel
 "live loaded" gland packing
 "cleaned and degreased for oxygen service"

Available options - on request only:

- Welded stainless steel stubs acc. to ISO 1127 or ASTM A312 - length FF + 200mm
- Extension H up to 900mm
- Valve with control disc (tapered design)
- Disc with PTFE/Carbon filled (25%) seal
- Further connection types



Applications:

Approved for air gases, vapours and cryogenic liquefied gases incl. LNG.
 Working temperature: -196°C / -321°F (77K) up to +120°C / +248°F (393K)
 Recommended working temperature (for versions without extension):
 -60°C / -76°F (213K) up to +120°C / +248°F (393K)

Materials	DIN EN	ASTM
1 Body	1.4308	A 351 CF8
2 Valve seal	PCTFE	
3 Disc	1.4301	A 479 Grade 304
4 Bonnet gasket	PTFE	
5 Headpiece	1.4308	A 351 CF8
6 Bolts	1.4301/A2	A 320 B8
7 Elongation tube	1.4541	A 213 TP 321
8 Stem	1.4301	A 479 Grade 304
9 Gland packing	Graphite / PTFE	
10 Gland nut	1.4305	A 276 Grade 303
11 Handwheel	Aluminium alloy	
12 Spring	1.4310	A 276 Grade 301
13 Bush	1.4541	A 479 Grade 321
14 Sleeve	1.4571	A 276 Grade 316Ti

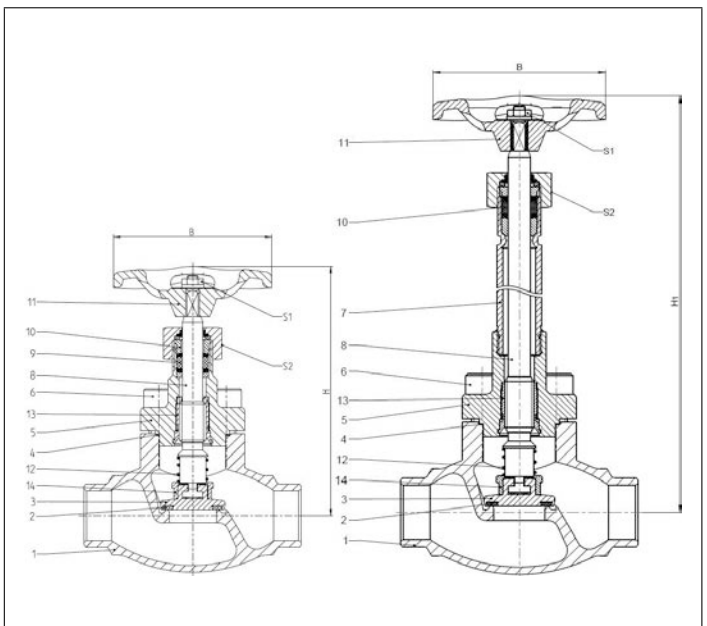

Standard marking acc. to Pressure Equipment Directive 97/23/EC (PED).



Technical Data - standard version

Nominal size [DN]	Height (H) [mm]	Height (H ₁) [mm]	Handwheel-Ø (B) [mm]	Wrench size across flats (S ₁) [mm]	Wrench size across flats (S ₂) [mm]
10	140	270/370	100	10	27
15	140	270/370	100	10	27
20	140	270/370	100	10	27
25	140	270/370	100	10	27
40	175	270/370	125	13	32
50	200	270/370	125	13	32

Globe Valves

Type 1116 - Globe Valve



Connection types

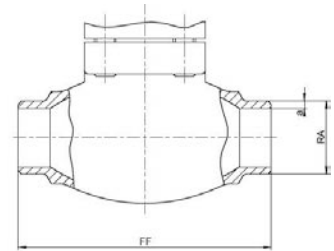

Butt weld connection acc. to

· ISO 1127

DN	Face-to-face dim. (FF) [mm]	Outside pipe-Ø (RA) [mm]	ISO Wall thickness pipe ISO (a) [mm]	Kvs-value [m ³ /h]	Cv-value [gal/min]	Weight, w.e.* [kg]	Part No.
10	70	13.5	2.3	1.6	1.9	0.85	1116.0135023.X0
15	85	17.2	1.6	3.8	4.4	0.96	1116.0172016.X0
15	85	21.3	2.0	4.3	5.0	0.98	1116.0213020.X0
20	100	26.9	2.0	6.7	7.8	1.43	1116.0269020.X0
25	115	33.7	2.6	11.5	13.4	1.92	1116.0337026.X0
40	130	42.4	2.6	20.6	23.9	3.49	1116.0424026.X0
40	130	48.3	2.6	22.6	26.3	3.36	1116.0483026.X0
50	155	60.3	2.6	37.1	43.2	4.94	1116.0603026.X0

Butt weld connection acc. to

· ASTM A312

DN	Face-to-face dim. (FF) [mm]	Outside pipe-Ø (RA) [mm]	ASTM Wall thickness pipe ASTM (a) [mm]	Kvs-value [m ³ /h]	Cv-value [gal/min]	Weight, w.e.* [kg]	Part No.
10	70	13.7	2.3	1.6	1.9	0.85	1116.0137S40.X0
15	85	17.1	1.6	3.8	4.4	0.96	1116.0171S10.X0
15	85	21.3	2.1	4.3	5.0	0.98	1116.0213S10.X0
20	100	26.6	2.1	6.7	7.8	1.43	1116.0266S10.X0
25	115	33.4	2.7	11.5	13.4	1.92	1116.0334S10.X0
40	130	42.4	2.7	20.6	23.9	3.49	1116.0424S10.X0
40	130	48.2	2.7	22.6	26.3	3.36	1116.0482S10.X0
50	155	60.3	2.7	37.1	43.2	4.94	1116.0603S10.X0

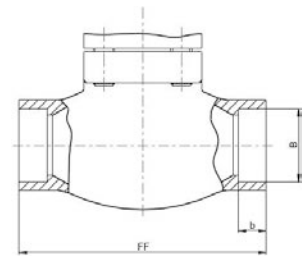

Socket weld connection acc. to

· ISO 1127

· ASTM A312

DN	Face-to-face dim. (FF) [mm]	Socket depth (b) [mm]	Socket diameter (B) [mm]	Kvs-value [m ³ /h]	Cv-value [gal/min]	Weight, w.e.* [kg]	Part No.
10	70	6.0	14.1	1.6	1.9	0.85	1116.0141000.X0
15	85	8.0	17.5	3.8	4.4	0.96	1116.0175000.X0
15	85	10.0	21.5	4.3	5.0	0.98	1116.0215000.X0
20	100	13.0	27.5	6.7	7.8	1.43	1116.0275000.X0
25	115	13.0	34.1	11.5	13.4	1.92	1116.0341000.X0
40	130	13.0	42.8	20.6	23.9	3.49	1116.0428000.X0
40	130	13.0	48.65	22.6	26.3	3.36	1116.0486000.X0
50	155	16.0	61.1	37.1	43.2	4.94	1116.0611000.X0

* w.e. = without extension

X = 0 (without extension), 1 (with 270mm extension), 2 (with 370mm extension)

Globe Valves

Type 1116 - Globe Valve



Connection types

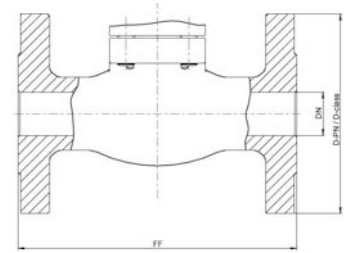

Flanged connection acc. to

- DIN EN 1092-1 PN40
- ANSI B16.5 class 300

DN / NPS	Face-to-face dim. (FF) [mm]	Flange-Ø (D-PN) [mm]	Flange-Ø (D-class) [mm]	Kvs-value [m ³ /h]	Cv-value [gal/min]	Weight, w.e.* [kg]	Part No. DIN EN	Part No. ANSI
15 / 1/2***	161	95	95	4.3	5.0	2.86	1116.015P040.X0	1116.015C300.X0
20 / 3/4***	181	105	115	6.7	7.8	3.72	1116.020P040.X0	1116.020C300.X0
25 / 1"	160	115	125	11.5	13.4	4.60	1116.025P040.X0	1116.025C300.X0
40 / 1-1/2"	200	150	155	22.6	26.3	8.62	1116.040P040.X0	1116.040C300.X0
50 / 2"	230	165	165	37.1	43.2	12.48	1116.050P040.X0	1116.050C300.X0

** welded version

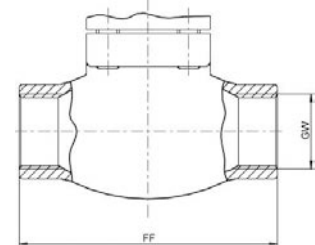

Female thread connection acc. to

- ISO 228/1 (G)
- NPT acc. to ANSI B 1.20.1 (NPT)

DN	Face-to-face dim. (FF) [mm]	Thread size (GW)	Kvs-value [m ³ /h]	Cv-value [gal/min]	Weight, w.e.* [kg]	Part No. G-thread	Part No. NPT-thread
10	70	1/4"	1.6	1.9	0.85	1116.FG02000.X0	1116.FN02000.X0
10	70	3/8"	2.2	2.6	0.85	1116.FG03000.X0	1116.FN03000.X0
15	85	1/2"	4.3	5.0	0.98	1116.FG04000.X0	1116.FN04000.X0
20	100	3/4"	6.7	7.8	1.43	1116.FG06000.X0	1116.FN06000.X0
25	115	1"	11.5	13.4	1.92	1116.FG10000.X0	1116.FN10000.X0
40	130	1-1/4"	20.6	23.9	3.49	1116.FG12000.X0	1116.FN12000.X0
40	130	1-1/2"	22.6	26.3	3.36	1116.FG14000.X0	1116.FN14000.X0
50	155	2"	37.1	43.2	4.94	1116.FG20000.X0	1116.FN20000.X0

Female thread connection acc. to

- ISO 7-1 (Rc or Rp)

DN	Face-to-face dim. (FF) [mm]	Thread size (GW)	Kvs-value [m ³ /h]	Cv-value [gal/min]	Weight, w.e.* [kg]	Part No. Rc-thread	Part No. Rp-thread
10	70	1/4"	1.6	1.9	0.85	1116.FR02000.X0	1116.FP02000.X0
10	70	3/8"	2.2	2.6	0.85	1116.FR03000.X0	1116.FP03000.X0
15	85	1/2"	4.3	5.0	0.98	1116.FR04000.X0	1116.FP04000.X0
20	100	3/4"	6.7	7.8	1.43	1116.FR06000.X0	1116.FP06000.X0
25	115	1"	11.5	13.4	1.92	1116.FR10000.X0	1116.FP10000.X0
40	130	1-1/4"	20.6	23.9	3.49	1116.FR12000.X0	1116.FP12000.X0
40	130	1-1/2"	22.6	26.3	3.36	1116.FR14000.X0	1116.FP14000.X0
50	155	2"	37.1	43.2	4.94	1116.FR20000.X0	1116.FP20000.X0

* w.e. = without extension

X = 0 (without extension), 1 (with 270mm extension), 2 (with 370mm extension)

Edition 2016-01

Angle Valves

Type 01332 - Globe Valve Angle Type



Cryogenic-Globe Valves Angle Type, PN50

Stainless steel body and bronze topwork,
 "live loaded" Stainless steel body and bronze topwork,
 "cleaned and degreased for oxygen service"

Part No. 01332.X.000*

* Butt weld connection for stainless steel pipes acc. to ISO 1127 or ASTM A312

Part No. 01332.X.0004

Socket weld connection for stainless steel pipes acc. to ISO 1127 or ASTM A312

Available options - on request only:

- Valve with control disc (tapered design)
- Valve with check disc

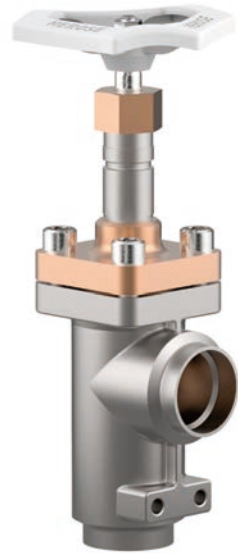

Applications:

Approved for air gases, vapours and cryogenic liquefied gases incl. LNG.

Working temperature: -196°C / -321°F (77K) up to +120°C / +248°F (393K)

Recommended working temperature: -60°C / -76°F (213K) up to +120°C / +248°F (393K)

Materials	DIN EN	ASTM
1 Body	1.4308	A 351 CF8
2 Valve seal	PTFE / Carbon filled (25%)	
3 Disc	CW614N	B 283 UNS C38500
4 Bonnet gasket	PTFE	
5 Headpiece	CC493K	B 505 UNS C93200
6 Bolts	1.4301/A2	A 194 B8
7 Stem	1.4301	A 276 Grade 304
9 Gland packing	Graphite / PTFE	
10 Gland nut	CW614N	B 283 UNS C38500
11 Handwheel	Aluminium alloy	

Standard marking acc. to Pressure Equipment Directive 97/23/EC (PED).

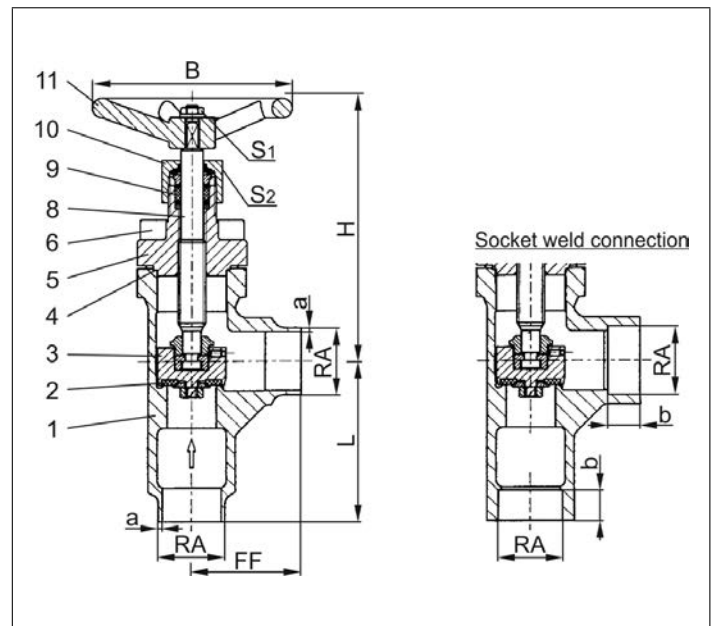

Type 01332 - Standard design	Technical data						
Nominal size	DN	15	20	25	32	40	50
Dimension code	.X.	1521	2026	2533	3242	4048	5060
Face-to-face dimension	FF	40	50	55	60	58	85
Height	H	140	140	140	170	175	200
Outside pipe-Ø ISO 1127	RA	21.3	26.9	33.7	42.0	48.3	60.3
Wall thickness pipe ISO 1127	a	2.0	2.0	2.0	2.0	2.0	2.0
Outside pipe-Ø ASTM A312	RA	21.34	26.67	33.4	-	48.26	60.33
Wall thickness pipe ASTM A312	a	dimensions acc. to S10 or S40					
Socket depth	b	10	13	13	13	13	16
Handwheel-Ø	B	100	100	100	125	125	125
Length	L	50	65	80	80	90	90
Wrench size across flats	S ₁	10	10	10	13	13	13
Wrench size across flats	S ₂	30	30	30	36	36	36
Weight	ca. kg	1.0	1.3	1.7	3.1	3.3	6.0
Kvs-Value	m ³ /h	6.0	10.5	17.2	32.0	35.0	57.0
Cv-Value	gal/min	7.0	12.2	20.0	37.2	40.7	66.3

Dimensions in mm.

Angle Valves

Type 01352 - Globe Valve Angle Type



Cryogenic-Globe Valves Angle Type, PN50

- Stainless steel body and topwork,
- "live loaded" gland packing
- "cleaned and degreased for oxygen service"

Part No. 01352.X.000*

* Butt weld connection for stainless steel pipes acc. to ISO 1127 or ASTM A312

Part No. 01352.X.0004

Socket weld connection for stainless steel pipes acc. to ISO 1127 or ASTM A312

Available options - on request only:

- Valve with control disc (tapered design)
- Valve with check disc



Applications:

Approved for air gases, vapours and cryogenic liquefied gases incl. LNG.

Working temperature: -196°C / -321°F (77K) up to +120°C / +248°F (393K)

Recommended working temperature: -60°C / -76°F (213K) up to +120°C / +248°F (393K)

Materials	DIN EN	ASTM
1 Body	1.4308	A 351 CF8
2 Valve seal	PTFE / Carbon filled (25%)	
3 Disc	1.4301	A 276 Grade 304
4 Bonnet gasket	PTFE	
5 Headpiece	1.4301 / 1.4308	A 276 Grade 304 / A 351 CF8
6 Bolts	1.4301/A2 A 194 B8	
8 Stem	1.4301	A 276 Grade 304
9 Gland packing	Graphite / PTFE	
10 Gland nut	1.4305	A 276 Grade 303
11 Handwheel	Aluminium alloy	
13 Bush	CW452K	B 159 UNS C51900

Standard marking acc. to Pressure Equipment Directive 97/23/EC (PED).

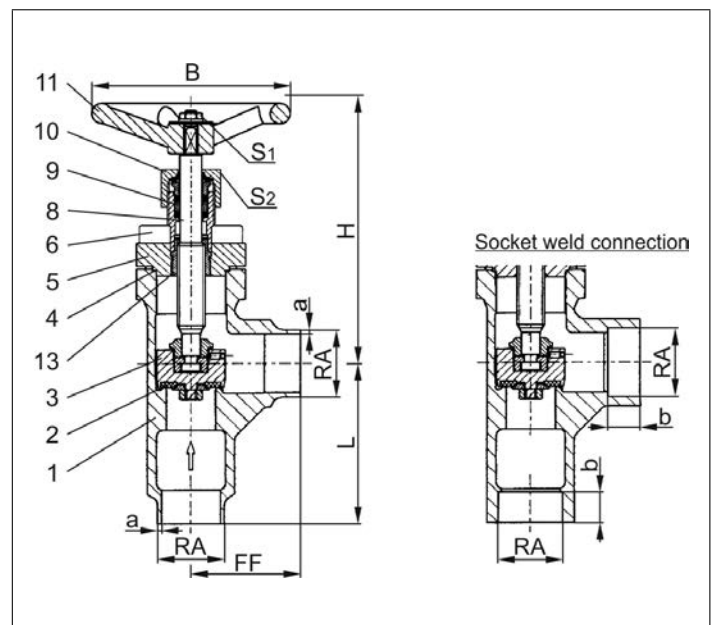

Type 01352 - Standard design	Technical data						
Nominal size	DN	15	20	25	32	40	50
Dimension code	.X.	1521	2026	2533	3242	4048	5060
Face-to-face dimension	FF	40	50	55	60	58	85
Height	H	140	140	140	170	175	200
Outside pipe-Ø ISO 1127	RA	21.3	26.9	33.7	42.0	48.3	60.3
Wall thickness pipe ISO 1127	a	2.0	2.0	2.0	2.0	2.0	2.0
Outside pipe-Ø ASTM A312	RA	21.34	26.67	33.4	-	48.26	60.33
Wall thickness pipe ASTM A312	a	dimensions acc. to S10 or S40					
Socket depth	b	10	13	13	13	13	16
Handwheel-Ø	B	100	100	100	125	125	125
Length	L	50	65	80	80	90	90
Wrench size across flats	S ₁	10	10	10	13	13	13
Wrench size across flats	S ₂	30	30	30	36	36	36
Weight	ca. kg	1.0	1.3	1.7	3.1	3.3	6.0
Kvs-Value	m ³ /h	6.0	10.5	17.2	32.0	35.0	57.0
Cv-Value	gal/min	7.0	12.2	20.0	37.2	40.7	66.3

Dimensions in mm.

Angle Valves

Type 01322 - Globe Valve Angle Type



Cryogenic-Globe Valves Angle Type, PN50

Stainless steel body and bronze topwork
 "live loaded" gland packing
 "cleaned and degreased for oxygen service"

Part No. 01322.X.001* (H = 270mm)

Part No. 01322.X.002* (H = 370mm)

* Butt weld connection for stainless steel pipes acc. to ISO 1127 or ASTM A312

Part No. 01322.X.0014 (H = 270mm)

Part No. 01322.X.0024 (H = 370mm)

Socket weld connection for stainless steel pipes acc. to ISO 1127 or ASTM A312

Available options - on request only:

- Extension H up to 900mm
- Valve with control disc (tapered design)
- Valve with check disc



Applications:

Approved for air gases, vapours and cryogenic liquefied gases incl. LNG.

Working temperature: -196°C / -321°F (77K) up to +120°C / +248°F (393K)

Materials	DIN EN	ASTM
1 Body	1.4308	A 351 CF8
2 Valve seal	PTFE / Carbon filled (25%)	
3 Disc	CW614N	B 283 UNS C38500
4 Bonnet gasket	PTFE	
5 Headpieceflansch	CC493K	B 505 UNS C93200
6 Bolts	1.4301/A2	A 194 B8
7 Elongation tube	1.4541	A 213 TP 321
8 Stem	1.4301	A 276 Grade 304
9 Gland packing	Graphite / PTFE	
10 Gland nut	CW614N	B 283 UNS C38500
11 Handwheel	Aluminium alloy	

Standard marking acc. to Pressure Equipment Directive 97/23/EC (PED).

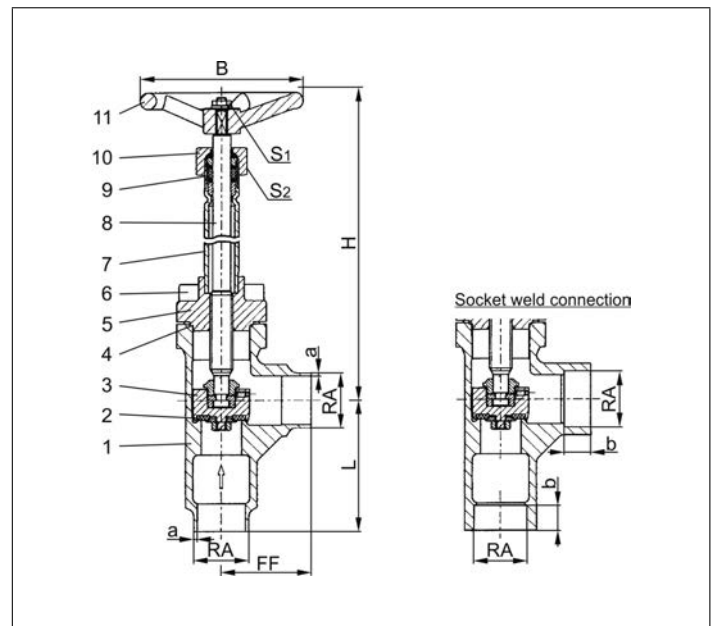

Type 01322 - Standard design	Technical data						
Nominal size	DN	15	20	25	32	40	50
Dimension code	.X.	1521	2026	2533	3242	4048	5060
Face-to-face dimension	FF	40	50	55	60	58	85
Height	H	270mm or 370mm					
Outside pipe-Ø ISO 1127	RA	21.3	26.9	33.7	42.0	48.3	60.3
Wall thickness pipe ISO 1127	a	2.0	2.0	2.0	2.0	2.0	2.0
Outside pipe-Ø ASTM A312	RA	21.34	26.67	33.40	-	48.26	60.33
Wall thickness pipe ASTM A312	a	dimensions acc. to S10 or S40					
Socket depth	b	10	13	13	13	13	16
Handwheel-Ø	B	100	100	100	125	125	125
Length	L	50	65	80	80	90	90
Wrench size across flats	S ₁	10	10	10	13	13	13
Wrench size across flats	S ₂	30	30	30	36	36	36
Weight	ca. kg	1.4	1.6	2.2	4.0	4.3	6.5
Kvs-Value	m ³ /h	6.0	10.5	17.2	32.0	35.0	57.0
Cv-Value	gal/min	7.0	12.2	20.0	37.2	40.7	66.3

Dimensions in mm.

Angle Valves

Type 01342 - Globe Valve Angle Type



Cryogenic-Globe and Globe/Check Valves, PN50

Stainless steel body and topwork,
 "live loaded" gland packing
 "cleaned and degreased for oxygen service"

Part No. 01342.X.001* (H = 270mm)

Part No. 01342.X.002* (H = 370mm)

* Butt weld connection for stainless steel pipes acc. to ISO 1127 or ASTM A312

Part No. 01342.X.0014 (H = 270 mm)

Part No. 01342.X.0024 (H = 370 mm)

Socket weld connection for stainless steel pipes acc. to ISO 1127 or ASTM A312

Available options - on request only:

- Extension H up to 900mm
- Valve with control disc (tapered design)
- Valve with check disc



Applications:

Approved for air gases, vapours and cryogenic liquefied gases incl. LNG.

Working temperature: -196°C / -321°F (77K) up to +120°C / +248°F (393K)

Materials	DIN EN	ASTM
1 Body	1.4308	A 351 CF8
2 Valve seal	PTFE / Carbon filled (25%)	
3 Disc	1.4301	A 276 Grade 304
4 Bonnet gasket	PTFE	
5 Headpiece	1.4301 / 1.4308	A 276 Grade 304 / A 351 CF8
6 Bolts	1.4301/A2	A 194 B8
7 Elongation tube	1.4541	A 213 TP 321
8 Stem	1.4301	A 276 Grade 304
9 Gland packing	Graphite / PTFE	
10 Gland nut	1.4305	A 276 Grade 303
11 Handwheel	Aluminium alloy	
13 Bush	CW452K	B 159 UNS C51900

Standard marking acc. to Pressure Equipment Directive 97/23/EC (PED).

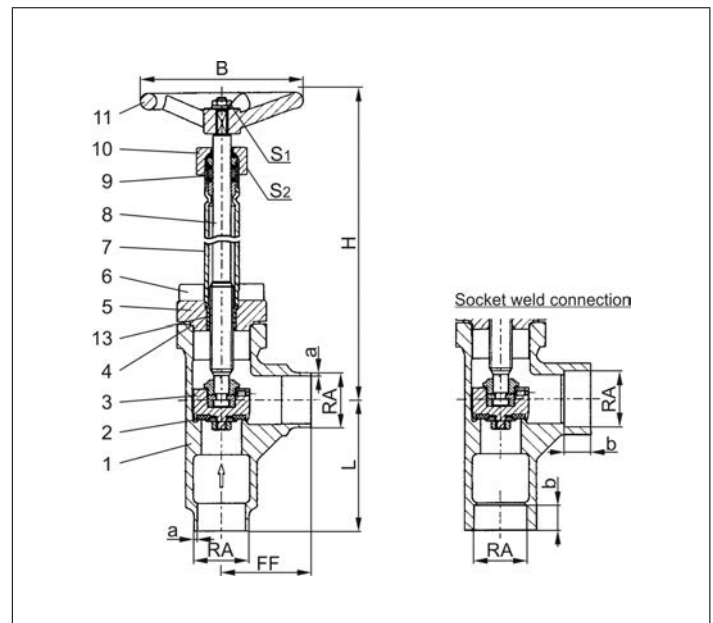

Type 01342 - Standard design	Technical data						
Nominal size	DN	15	20	25	32	40	50
Dimension code	.X.	1521	2026	2533	3242	4048	5060
Face-to-face dimension	FF	40	50	55	60	58	85
Height	H	270 mm or 370 mm					
Outside pipe-Ø ISO 1127	RA	21.3	26.9	33.7	42.0	48.3	60.3
Wall thickness pipe ISO 1127	a	2.0	2.0	2.0	2.0	2.0	2.0
Outside pipe-Ø ASTM A312	RA	21.34	26.67	33.4	-	48.26	60.33
Wall thickness pipe ASTM A312	a	dimensions acc. to S10 or S40					
Socket depth	b	10	13	13	13	13	16
Handwheel-Ø	B	100	100	100	125	125	125
Length	L	50	65	80	80	90	90
Wrench size across flats	S ₁	10	10	10	13	13	13
Wrench size across flats	S ₂	30	30	30	36	36	36
Weight	ca. kg	1.4	1.6	2.2	4.0	4.3	6.5
Kvs-Value	m ³ /h	6.0	10.5	17.2	32.0	35.0	57.0
Cv-Value	gal/min	7.0	12.2	20.0	37.2	40.7	66.3

Dimensions in mm.

Gate Valves

Type 09340 - Gate Valve



Cryogenic-Gate Valves, PN50

Stainless steel body and topwork,
 one way tightening (in flow direction),
 "live loaded" gland packing
 "cleaned and degreased for oxygen service"

Part No. 09340.X.001* (Height H for size DN25, DN40 und DN100)

Part No. 09340.X.002* (Height H for size DN50, DN65 und DN80)

* Butt weld connection for stainless steel pipes acc. to ISO 1127 or ASTM A312

Part No. 09340.X.0014 (Height H for size DN25, DN40 und DN100)

Part No. 09340.X.0024 (Height H for size DN50, DN65 und DN80)

Socket weld connection for stainless steel pipes acc. to ISO 1127 or ASTM A312

Available options - on request only:

· other connections are in preparation



Applications:

Approved for air gases, vapours and cryogenic liquefied gases incl. LNG.

Working temperature: -196°C / -321°F (77K) up to +120°C / +248°F (393K)

Materials	DIN EN	ASTM
1 Body	1.4308	A 351 CF8
2 Valve seal	PTFE / Carbon filled (25%)	
3 Disc	CW452K B 159 UNS C51900	
4 Wedge	1.4308	A 351 CF8
5 Stem	1.4301	A 276 Grade 304
6 Bonnet gasket	PTFE	
7 Headpiece	1.4308	A 351 CF8
8 Bolts	1.4301/A2 A 194 B8	
9 Elongation tube	1.4541	A 213 TP 321
10 Gland packing	Graphite / PTFE	
11 Gland nut	1.4305	A 276 Grade 303
12 Handwheel	Aluminium alloy	
13 Bush	CW452K B 159 UNS C51900	

Standard marking acc. to Pressure Equipment Directive 97/23/EC (PED).

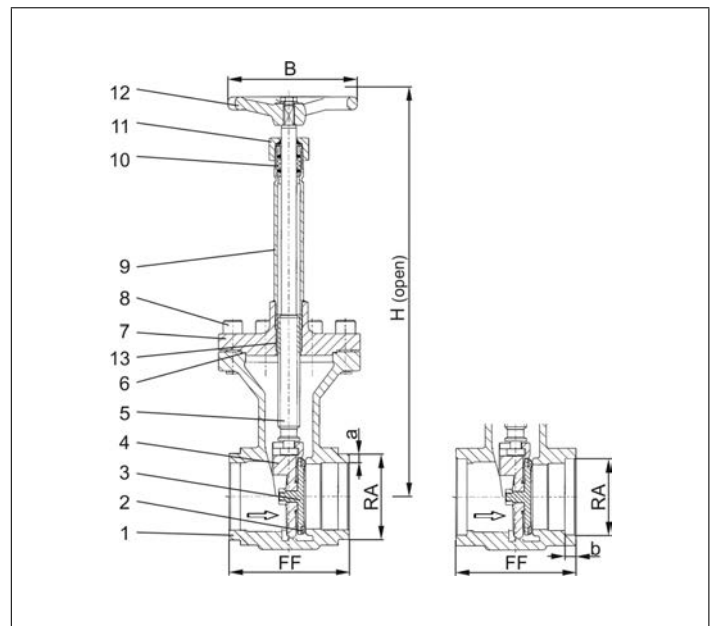

Type 09340 - Standard design	Technical data						
Nominal size	DN	25	40	50	65	80	100
Dimension code	.X.	2533	4048	5060	657x	8088	0114
Face-to-face dimension	FF	133	133	110	110	110	130
Height	H	330	360	410	440	450	570
Outside pipe-Ø ISO 1127	RA	33.7	48.3	60.3	76.1	88.9	114.3
Wall thickness pipe ISO 1127	a	2.0	2.0	2.0	2.6	3.2	3.2
Outside pipe-Ø ASTM A312	RA	33.40	48.26	60.33	73.03	88.90	114.3
Wall thickness pipe ASTM A312	a	dimensions acc. to S10 or S40					
Socket depth	b	8	13	16	16	16	20
Handwheel-Ø	B	125	125	150	150	150	200
Weight	ca. kg	3.3	4.8	7.5	8.6	11.4	21.8
Kvs - Wert	m ³ /h	43	93	125	283	310	792
Cv - Wert	gal/min	51	111	149	337	369	943

Dimensions in mm.

Gate Valves

Type 09345 - Gate valve



Cryogenic-Gate Valves, PN50

Stainless steel body and topwork,
 one way tightening (in flow direction),
 "live loaded" gland packing
 "cleaned and degreased for oxygen service"

Part No. 09345.X.0011*

Female thread connection (G) acc. to ISO 228/1

Part No. 09345.X.0015

Female thread connection (R) acc. to ISO 7-Rc

Part No. 09345.X.0016

Female thread connection (NPTF) acc. to ANSI 1.20.1

Available options - on request only:

- other connections are in preparation



Applications:

Approved for air gases, vapours and cryogenic liquefied gases incl. LNG.

Working temperature: -196°C / -321°F (77K) up to +120°C / +248°F (393K)

Materials	DIN EN	ASTM
1 Body	1.4308	A 351 CF8
2 Valve seal	PTFE / Carbon filled (25%)	
3 Disc	CW452K	B 159 UNS C51900
4 Wedge	1.4308	A 351 CF8
5 Stem	1.4301	A 276 Grade 304
6 Bonnet gasket	PTFE	
7 Headpiece	1.4308	A 351 CF8
8 Bolts	1.4301/A2	A 194 B8
9 Elongation tube	1.4541	A 213 TP 321
10 Gland packing	Graphite / PTFE	
11 Gland nut	1.4305	A 276 Grade 303
12 Handwheel	Aluminium alloy	
13 Bush	CW452K	B 159 UNS C51900

Standard marking acc. to Pressure Equipment Directive 97/23/EC (PED).

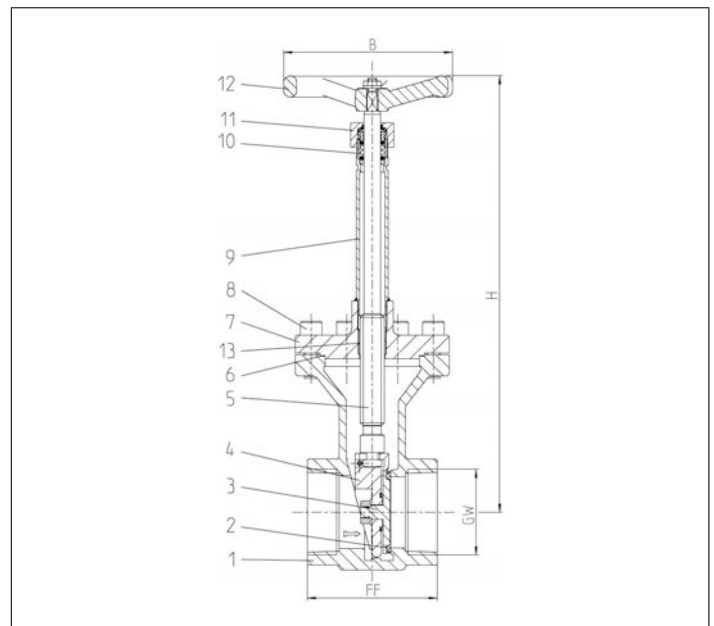

Type 09345 - Standard design	Technical data				
Nominal size	DN	25	40	50	65
Thread size	GW	1	1-1/2	2	2-1/2
Dimension code	.X.	1000	1400	2000	2400
Face-to-face dimension	FF	133	133	110	110
Height	H	330	360	410	440
Handwheel-Ø	B	125	125	150	150
Weight	ca. kg	3.3	4.8	7.5	8.6
Kvs - Value	m ³ /h	43	93	125	283
Cv - Value	gal/min	51	111	149	337

Dimensions in mm.

Gate Valves

Type 09440 - Gate valve



Cryogenic-Gate Valves, PN50

Stainless steel body and topwork,
 one way tightening (in flow direction),
 "live loaded" gland packing
 "cleaned and degreased for oxygen service"

Part No. 09440.X.0121

Male thread for union connection

Available options - on request only:

- other connections are in preparation



Applications:

Approved for air gases, vapours and cryogenic liquefied gases incl. LNG.

Working temperature: -196°C / -321°F (77K) up to +120°C / +248°F (393K)

Materials	DIN EN	ASTM
1 Body	1.4308	A 351 CF8
2 Valve seal	PTFE / Carbon filled (25%)	
3 Disc	CW452K	B 159 UNS C51900
4 Wedge	1.4308	A 351 CF8
5 Stem	1.4301	A 276 Grade 304
6 Bonnet gasket	PTFE	
7 Headpiece	1.4301	A 276 Grade 304
8 Bolts	1.4301/A2	A 194 B8
9 Elongation tube	1.4541	A 213 TP 321
10 Gland packing	Graphite / PTFE	
11 Gland nut	1.4305	A 276 Grade 303
12 Handwheel	Aluminium alloy	
13 Bush	CW452K	B 159 UNS C51900

Standard marking acc. to Pressure Equipment Directive 97/23/EC (PED).

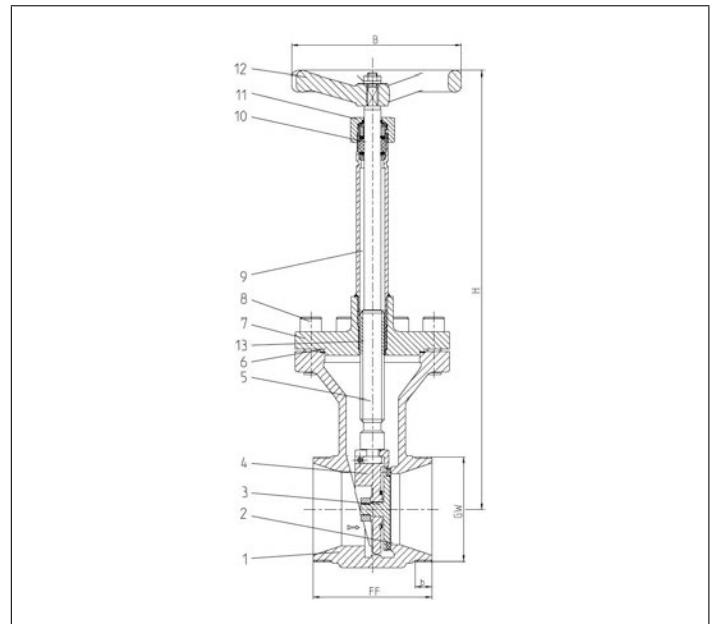

Type 09440 - Standard design	Technical data				
Nominal size	DN	25	40	50	65
Thread size	GW	1	1-1/2	2	2-1/2
Dimension code	.X.	0250	0400	0500	0650
Face-to-face dimension	FF	133	133	110	110
Height	H	330	360	410	440
Thread type (G- / M-thread)	b	- / M40x2	G2 / M65x2	G2-1/2 / M78x2	G3 / M88x2
Handwheel-Ø	B	125	125	150	150
Weight	ca. kg	3.3	4.8	7.5	8.6
Kvs - Value	m ³ /h	43	93	125	283
Cv - Value	gal/min	51	111	149	337

Dimensions in mm. * o.r.= on request

Gate Valves

Type 09440 - Gate valve



Cryogenic-Gate Valves, PN50

Stainless steel body and topwork,
 one way tightening (in flow direction),
 "live loaded" gland packing
 "cleaned and degreased for oxygen service"

Part No. 09440.X.002*

Completed with union type butt weld fittings for stainless steel pipes
 acc.to ISO 1127 or ASTM A312

Available options - on request only:

- other connections are in preparation



Applications:

Approved for air gases, vapours and cryogenic liquefied gases incl. LNG.
 Working temperature: -196°C / -321°F (77K) up to +120°C / +248°F (393K)

Materials	DIN EN	ASTM
1 Body	1.4308	A 351 CF8
2 Valve seal	PTFE / Carbon filled (25%)	
3 Disc	CW452K	B 159 UNS C51900
4 Wedge	1.4308	A 351 CF8
5 Stem	1.4301	A 276 Grade 304
6 Bonnet gasket	PTFE	
7 Headpiece	1.4301	A 276 Grade 304
8 Bolts	1.4301/A2	A 194 B8
9 Elongation tube	1.4541	A 213 TP 321
10 Gland packing	Graphite / PTFE	
11 Gland nut	1.4305	A 276 Grade 303
12 Handwheel	Aluminium alloy	
13 Bush	CW452K	B 159 UNS C51900
14 Weld fitting	1.4301	A 276 Grade 304
15 Union nut	1.4301	A 276 Grade 304

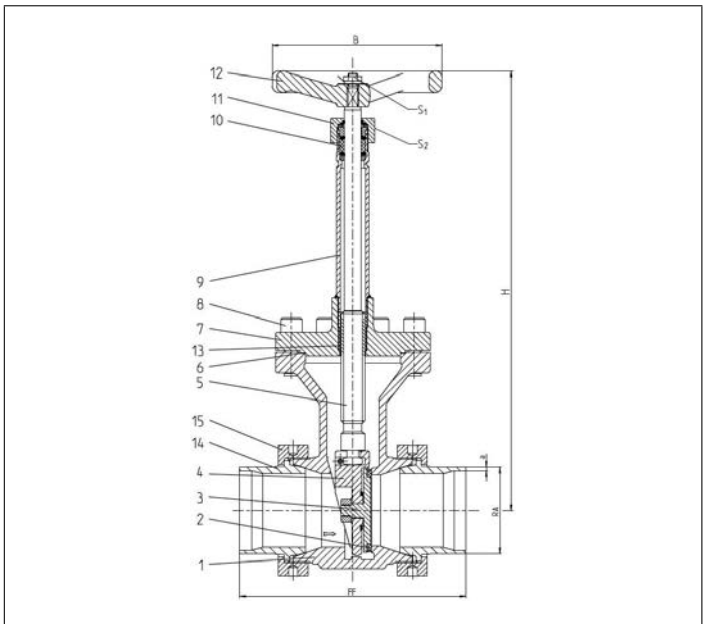

Standard marking acc. to Pressure Equipment Directive 97/23/EC (PED).



Type 09440 - Standard design	Technical data						
Nominal size	DN	25	40	50	65	80	100
Dimension code	.X.	2533	4048	5060	657x	8088	0114
Face-to-face dimension	FF	133	133	110	110	110	130
Height	H	330	360	410	440	450	570
Outsid pipe-Ø ISO 1127	RA	33.7	48.3	60.3	76.1	88.9	114.3
Wall thickness pipe ISO 1127	a	2.0	2.0	2.0	2.6	3.2	3.2
Outsid pipe-Ø ASTM A312	RA	33.40	48.26	60.33	73.03	88.90	114.3
Wall thickness pipe ASTM A312	a	dimensions acc. to S10 or S40					
Handwheel-Ø	B	125	125	150	150	150	200
Weight	ca. kg	3.3	4.8	7.5	8.6	11.4	21.8
Kvs - Value	m ³ /h	43	93	125	283	310	792
Cv - Value	gal/min	51	111	149	337	369	943

Dimensions in mm.

Fill Cluster

Type 07003 - Fill cluster with check function



Cryogenic-Fill cluster, PN50

Bronze body and topwork
with check function and drain valve
"live loaded" gland packing
"cleaned and degreased for oxygen service"

Part No. 07003.X.7027

Fill connection: Female thread type R (BSPT) acc. to ISO 7-Rc
Outlet: 2x complete with brazed stainless steel stubs acc. to ASTM A312
Non-return unit metal to metal seated, leakage rate D acc. to EN12266-1

Available options - on request only:

- brazed stainless steel stubs acc. to ISO 1127
- integrable strainer

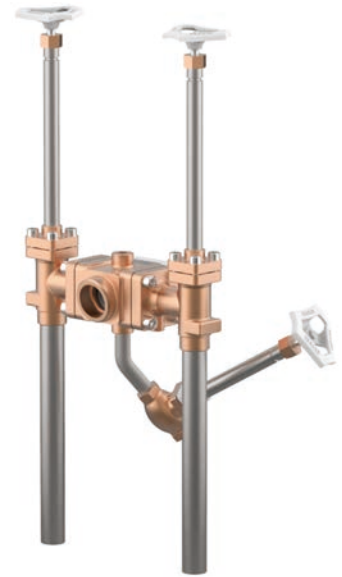

Applications:

Approved for air gases, vapours and cryogenic liquefied gases incl. LNG.
Working temperature: -196°C / -321°F (77K) up to +120°C / +248°F (393K)

Materials	DIN EN	ASTM
1 Fill body	CC491K	B 62 UNS C83600
2 Body	CC491K	B 62 UNS C83600
3 Valve seal	PTFE / Carbon filled (25%)	
4 Disc	CW614N	B 283 UNS C38500
5 Bonnet gasket	PTFE	
6 Headpiece	CC493K	B 505 UNS C93200
7 Bolts	1.4301/A2	A 194 B8
8 Elongation tube	1.4541	A 213 TP 321
9 Stem	1.4301	A 276 Grade 304
10 Gland packing	Graphite / PTFE	
11 Gland nut	CW614N	B 283 UNS C38500
12 Handwheel	Aluminium alloy	
14 Check disc	CW452K	B 159 UNS C51900
15 Spring	1.4571	A 313 Grade 316Ti
16 Cap	CC491K	B 62 UNS C83600
17 Stainless steel stubs	1.4306	A 312 TP304L

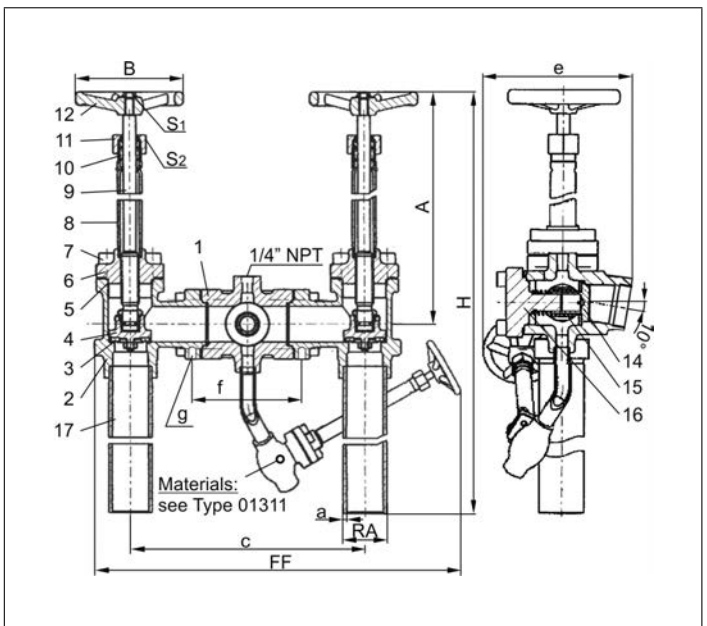

Standard marking acc. to Pressure Equipment Directive 97/23/EC (PED).



Type 07003 - Standard desig	Technical data		
Nominal size	DN	25	40
Dimension code	.X.	2533	4048
Face-to-face dimension	FF	340	340
Outside pipe-Ø ASTM A312	RA	33.40	48.26
Wall thickness pipe ASTM A312	a	dimensions acc. to S10 or S40	
Height	A	370	370
Height	H	735	735
Length	c	260	260
Length	e	172	172
Length	f	125	125
Thread	g	M10. 11 mm deep	M12. 13 mm deep
Handwheel-Ø	B	100	125
Wrench size across flats	S ₁	10	13
Wrench size across flats	S ₂	30	36
Weight	ca. kg	14.4	18.4

Dimensions in mm.

Fill Cluster

Type 07004 - Fill cluster with check function



Cryogenic-Fill cluster, PN50

Bronze body and topwork
with check function and drain valve
"live loaded" gland packing
"cleaned and degreased for oxygen service"

Part No. 07004.X.7027

Fill connection: Mueller flange
Outlet: 2x complete with brazed stainless steel stubs acc. to ASTM A312
Non-return unit metal to metal seated, leakage rate D acc. to EN12266-1

Available options - on request only:

- brazed stainless steel stubs acc. to ISO 1127
- integrable strainer



Applications:

Approved for air gases, vapours and cryogenic liquefied gases incl. LNG.
Working temperature: -196°C / -321°F (77K) up to +120°C / 248°F (393K)

Materials	DIN EN	ASTM
1 Fill body	CC491K	B 62 UNS C83600
2 Body	CC491K	B 62 UNS C83600
3 Valve seal	PTFE / Carbon filled (25%)	
4 Disc	CW614N	B 283 UNS C38500
5 Bonnet gasket	PTFE	
6 Headpiece	CC493K	B 505 UNS C93200
7 Bolts	1.4301/A2	A 194 B8
8 Elongation tube	1.4541	A 213 TP 321
9 Stem	1.4301	A 276 Grade 304
10 Gland packing	Graphite / PTFE	
11 Gland nut	CW614N	B 283 UNS C38500
12 Handwheel	Aluminium alloy	
14 Check disc	CW452K	B 159 UNS C51900
15 Spring	1.4571	A 313 Grade 316Ti
16 Cap	CC491K	B 62 UNS C83600
17 Stainless steel stubs	1.4306	A 312 TP304L

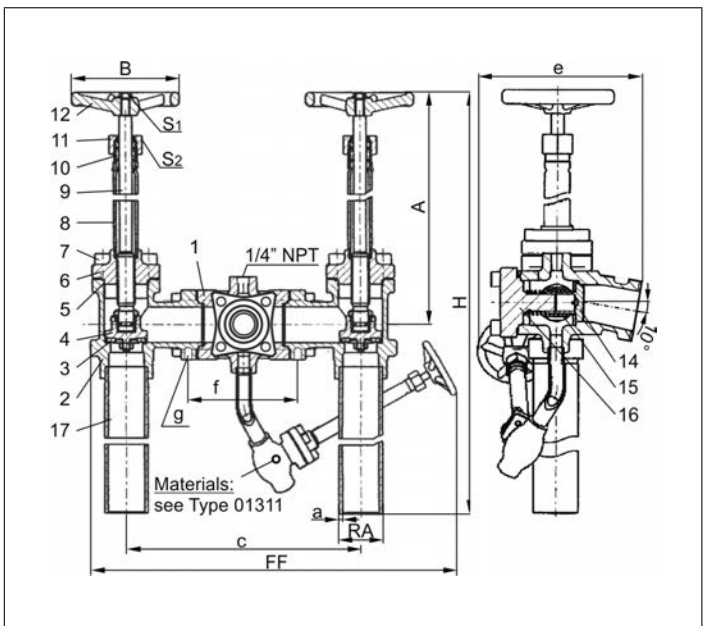

Standard marking acc. to Pressure Equipment Directive 97/23/EC (PED).



Type 07004 - Standard design	Technical data		
Nominal size	DN	25	40
Dimension code	.X.	2533	4048
Face-to-face dimension	FF	340	340
Outside pipe-Ø ASTM A312	RA	33.40	48.26
Wall thickness pipe ASTM A312	a	dimensions acc. to S10 or S40	
Height	A	370	370
Height	H	735	735
Length	c	260	260
Length	e	235	245
Length	f	125	125
Thread	g	M10. 11 mm deep	M12. 13 mm deep
Handwheel-Ø	B	100	125
Wrench size across flats	S ₁	10	13
Wrench size across flats	S ₂	30	36
Weight	ca. kg	15.4	19.4

Dimensions in mm.

Fill Cluster

Type 07015 - Fill cluster



Cryogenic-Fill cluster, PN50

Stainless steel body and bronze topwork
 "live loaded" gland packing
 "cleaned and degreased for oxygen service"

Part No. 07015.X.0000

Fill connection: Air Liquide specified flange
 Socket weld connection for stainless steel pipes
 acc. to ISO 1127 or ASTM A312

Available options - on request only:

- other fill connections
- integrable strainer

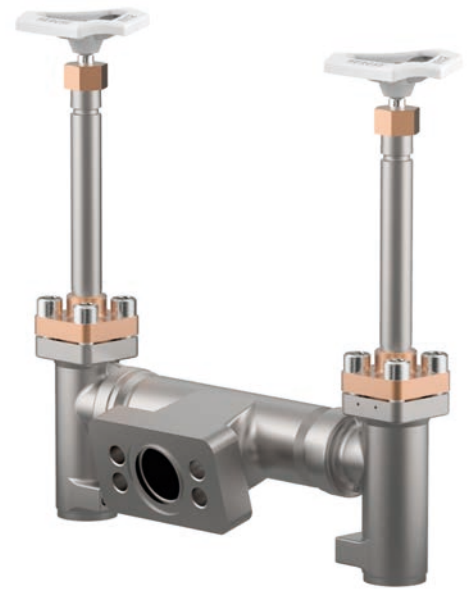

Applications:

Approved for air gases, vapours and cryogenic liquefied gases incl. LNG.
 Working temperature: -196°C / -321°F (77K) up to +120°C / +248°F (393K)

Materials	DIN EN	ASTM
1 Fill body	1.4308	A 351 CF8
2 Body	1.4308	A 351 CF8
3 Valve seal	PTFE / Carbon filled (25%)	
4 Disc	CW614N	B 283 UNS C38500
5 Bonnet gasket	PTFE	
6 Headpiece	CC493K	B 505 UNS C93200
7 Bolts	1.4301/A2	A 194 B8
8 Elongation tube	1.4541	A 213 TP 321
9 Stem	1.4301	A 276 Grade 304
10 Gland packing	Graphite / PTFE	
11 Gland nut	CW614N	B 283 UNS C38500
12 Handwheel	Aluminium alloy	

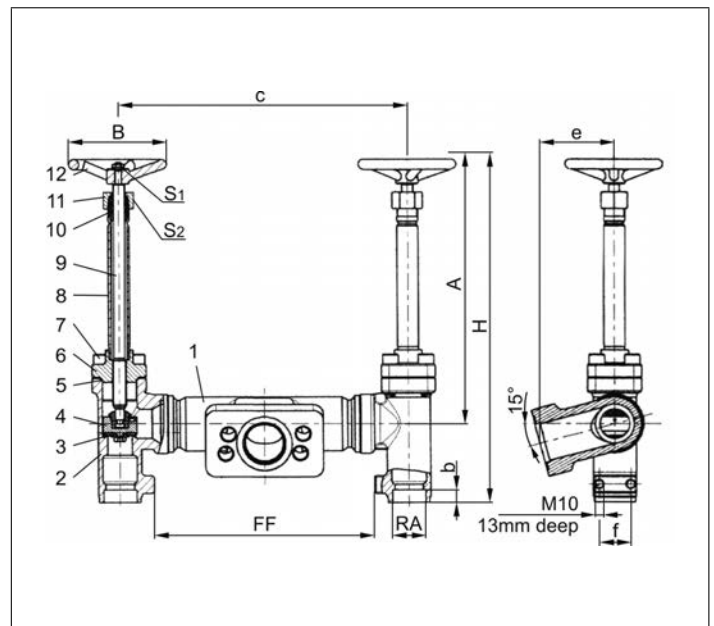

Standard marking acc. to Pressure Equipment Directive 97/23/EC (PED).



Type 07015 - Standard design	Technical data		
Nominal size	DN	25	40
Dimension code	.X.	2533	4048
Face-to-face dimension	FF	225	225
Outside pipe-Ø ISO 1127	RA	33.7	48.3
Outside pipe-Ø ASTM A312	RA	33.40	48.26
Socket depth	b	13	13
Height	A	270	270
Height	H	350	350
Length	c	295	301
Length	e	76	76
Length	f	32	32
Handwheel-Ø	B	100	125
Wrench size across flats	S ₁	10	13
Wrench size across flats	S ₂	30	36
Weight	ca. kg	8.4	11.2

Dimensions in mm.

Fill Cluster

Type 07015 - Fill cluster with check function



Cryogenic-Fill cluster, PN50

Stainless steel body and bronze topwork
with check function and drain valve
"live loaded" gland packing
"cleaned and degreased for oxygen service"

Part No. 07015.X.5000

Fill connection: Air Liquide specified flange
Socket weld connection for stainless steel pipes
acc. to ISO 1127 or ASTM A312
Non-return unit metal to metal seated, leakage rate D acc. to EN12266-1

Available options - on request only:

- other fill connections
- integrable strainer



Applications:

Approved for air gases, vapours and cryogenic liquefied gases incl. LNG.
Working temperature: -196°C / -321°F (77K) up to +120°C / +248°F (393K)

Materials	DIN EN	ASTM
1 Fill body	1.4308	A 351 CF8
2 Body	1.4308	A 351 CF8
3 Valve seal	PTFE / Carbon filled (25%)	
4 Disc	CW614N	B 283 UNS C38500
5 Bonnet gasket	PTFE	
6 Headpiece	CC493K	B 505 UNS C93200
7 Bolts	1.4301/A2	A 194 B8
8 Elongation tube	1.4541	A 213 TP 321
9 Stem	1.4301	A 276 Grade 304
10 Gland packing	Graphite / PTFE	
11 Gland nut	CW614N	B 283 UNS C38500
12 Handwheel	Aluminium alloy	
14 Check disc	CW452K	B 159 UNS C51900
15 Spring	1.4571	A 313 Grade 316Ti
16 Cap	CC493K	B 505 UNS C93200

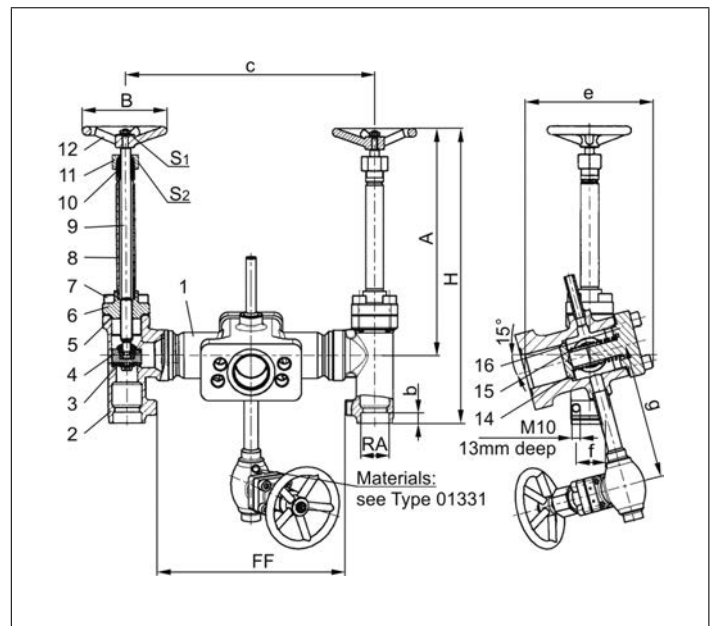

Standard marking acc. to Pressure Equipment Directive 97/23/EC (PED).



Type 07015 - Standard design	Technical data		
Nominal size	DN	25	40
Dimension code	.X.	2533	4048
Face-to-face dimension	FF	225	225
Outside pipe-Ø ISO 1127	RA	33.7	48.3
Outside pipe-Ø ASTM A312	RA	33.40	48.26
Socket depth	b	13	13
Height	A	270	270
Height	H	350	350
Length	c	295	301
Length	e	76	76
Length	f	32	32
Length	g	160	160
Handwheel-Ø	B	100	125
Wrench size across flats	S ₁	10	13
Wrench size across flats	S ₂	30	36
Weight	ca. kg	11.2	14.0

Dimensions in mm.

Fill Cluster

Type 07012 - Fill cluster with check function



Cryogenic-Fill cluster, PN40

Stainless steel body and bronze topwork
with check function and drain valve
"live loaded" gland packing
"cleaned and degreased for oxygen service"

Part No. 07012.X.5000

Fill connection: Flange DN40 acc. to DIN EN 1092-1 PN40
Socket weld connection for stainless steel pipes
acc. to ISO 1127 or ASTM A312
Non-return unit metal to metal seated, leakage rate D acc. to EN12266-1

Available options - on request only:

- other fill connections
- integrable strainer

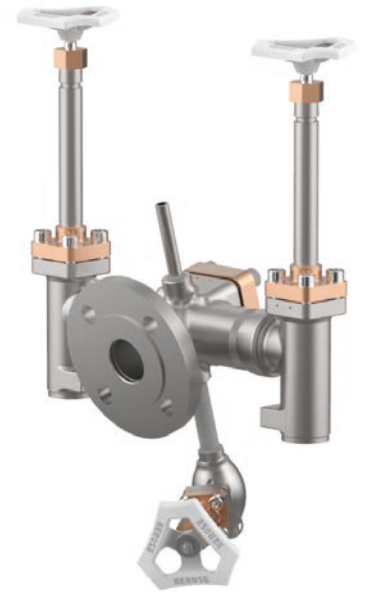

Applications:

Approved for air gases, vapours and cryogenic liquefied gases incl. LNG.
Working temperature: -196°C / -321°F (77K) up to +120°C / +248°F (393K)

Materials	DIN EN	ASTM
1 Fill body	1.4308	A 351 CF8
2 Body	1.4308	A 351 CF8
3 Valve seal	PTFE / Carbon filled (25%)	
4 Disc	CW614N	B 283 UNS C38500
5 Bonnet gasket	PTFE	
6 Headpiece	CC493K	B 505 UNS C93200
7 Bolts	1.4301/A2	A 194 B8
8 Elongation tube	1.4541	A 213 TP 321
9 Stem	1.4301	A 276 Grade 304
10 Gland packing	Graphite / PTFE	
11 Gland nut	CW614N	B 283 UNS C38500
12 Handwheel	Aluminium alloy	
14 Check disc	CW452K	B 159 UNS C51900
15 Spring	1.4571	A 313 Grade 316Ti
16 Cap	CC493K	B 505 UNS C93200

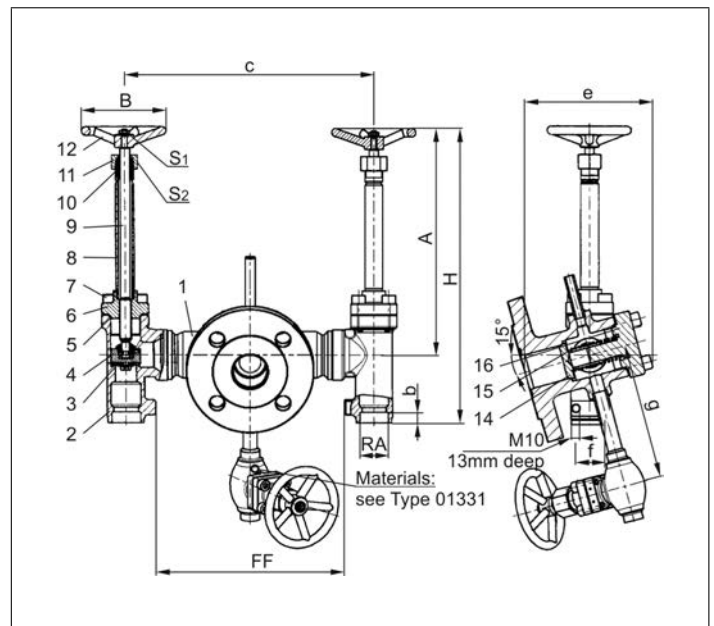

Standard marking acc. to Pressure Equipment Directive 97/23/EC (PED).



Type 07012 - Standard design	Technical data		
Nominal size	DN	25	40
Dimension code	.X.	2533	4048
Face-to-face dimension	FF	225	225
Outside pipe-Ø ISO 1127	RA	33.7	48.3
Outside pipe-Ø ASTM A312	RA	33.40	48.26
Socket depth	b	13	13
Height	A	270	270
Height	H	350	350
Length	c	295	301
Length	e	76	76
Length	f	32	32
Length	g	160	160
Handwheel-Ø	B	100	125
Wrench size across flats	S ₁	10	13
Wrench size across flats	S ₂	30	36
Weight	ca. kg	12.6	15.4

Dimensions in mm.

Fill Cluster

Type 07017 - Fill cluster



Cryogenic-Fill cluster, PN50

Stainless steel body and topwork
 "live loaded" gland packing
 "cleaned and degreased for oxygen service"

Part No. 07017.X.0000

Fill connection: Air Liquide specified flange
 Socket weld connection for stainless steel pipes
 acc. to ISO 1127 or ASTM A312

Available options - on request only:

- other fill connections
- integrable strainer

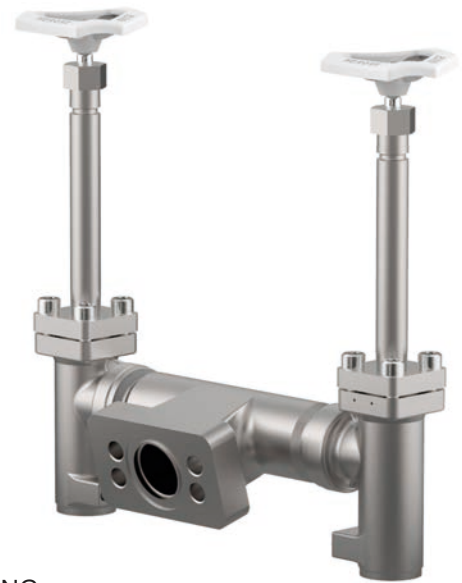

Applications:

Applications: Approved for air gases, vapours and cryogenic liquefied gases incl. LNG.
 Working temperature: -196°C / -321°F (77K) up to +120°C / +248°F (393K)

Materials	DIN EN	ASTM
1 Fill body	1.4308	A 351 CF8
2 Body	1.4308	A 351 CF8
3 Valve seal	PTFE / Carbon filled (25%)	
4 Disc	1.4301	A 276 Grade 304
5 Bonnet gasket	PTFE	
6 Headpiece	1.4308	A 351 CF8
7 Bolts	1.4301/A2	A 194 B8
8 Elongation tube	1.4541	A 213 TP 321
9 Stem	1.4301	A 276 Grade 304
10 Gland packing	Graphite / PTFE	
11 Gland nut	1.4305	A 276 Grade 303
12 Handwheel	Aluminium alloy	
13 Bush	CW452K	B 159 UNS C51900

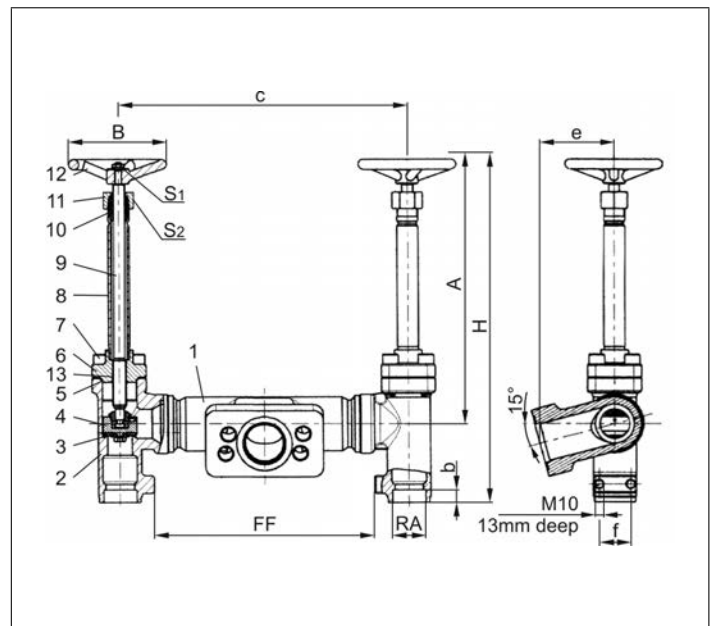

Standard marking acc. to Pressure Equipment Directive 97/23/EC (PED).



Type 07017 - Standard design	Technical data		
Nominal size	DN	25	40
Dimension code	.X.	2533	4048
Face-to-face dimension	FF	225	225
Outside pipe-Ø ISO 1127	RA	33.7	48.3
Outside pipe-Ø ASTM A312	RA	33.40	48.26
Socket depth	b	13	13
Height	A	270	270
Height	H	350	350
Length	c	295	301
Length	e	76	76
Length	f	32	32
Handwheel-Ø	B	100	125
Wrench size across flats	S ₁	10	13
Wrench size across flats	S ₂	30	36
Weight	ca. kg	8.4	11.2

Dimensions in mm.

Fill Cluster

Type 07017 - Fill cluster with check function



Cryogenic-Fill cluster, PN50

Stainless steel body and topwork
with check function and drain valve
"live loaded" gland packing
"cleaned and degreased for oxygen service"

Part No. 07017.X.5000

Fill connection: Air Liquide specified flange
Socket weld connection for stainless steel pipes
acc. to ISO 1127 or ASTM A312
Non-return unit metal to metal seated, leakage rate D acc. to EN12266-1

Available options - on request only:

- other fill connections
- integrable strainer



Applications:

Applications: Approved for air gases, vapours and cryogenic liquefied gases incl. LNG.
Working temperature: -196°C / -321°F (77K) up to +120°C / +248°F (393K)

Materials	DIN EN	ASTM
1 Fill body	1.4308	A 351 CF8
2 Body	1.4308	A 351 CF8
3 Valve seal	PTFE / Carbon filled (25%)	
4 Disc	1.4301	A 276 Grade 304
5 Bonnet gasket	PTFE	
6 Headpiece	1.4308	A 351 CF8
7 Bolts	1.4301/A2	A 194 B8
8 Elongation tube	1.4541	A 213 TP 321
9 Stem	1.4301	A 276 Grade 304
10 Gland packing	Graphite / PTFE	
11 Gland nut	1.4305	A 276 Grade 303
12 Handwheel	Aluminium alloy	
13 Bush	CW452K	B 159 UNS C51900
14 Check disc	1.4301	A 276 Grade 304
15 Spring	1.4571	A 313 Grade 316Ti
16 Cap	1.4301	A 276 Grade 304

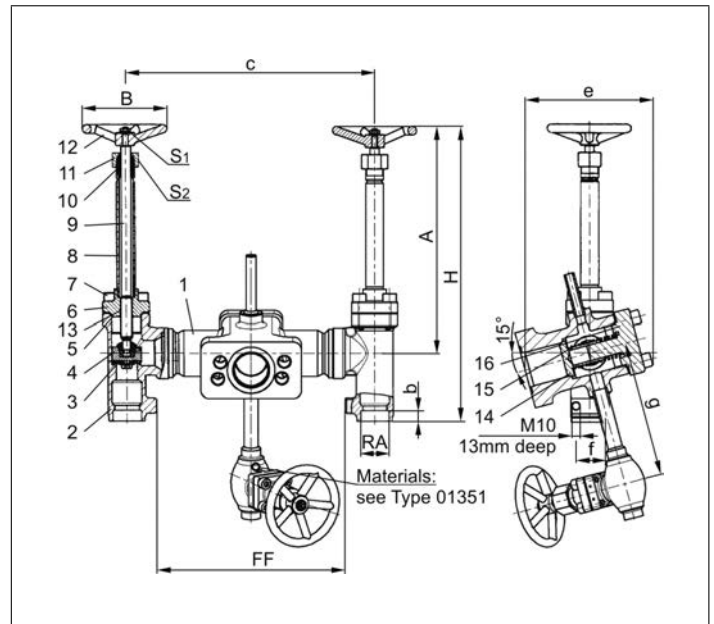

Standard marking acc. to Pressure Equipment Directive 97/23/EC (PED).



Type 07017 - Standard design	Technical data		
Nominal size	DN	25	40
Dimension code	.X.	2533	4048
Face-to-face dimension	FF	225	225
Outside pipe-Ø ISO 1127	RA	33.7	48.3
Outside pipe-Ø ASTM A312	RA	33.40	48.26
Socket depth	b	13	13
Height	A	270	270
Height	H	350	350
Length	c	295	301
Length	e	76	76
Length	f	32	32
Length	g	160	160
Handwheel-Ø	B	100	125
Wrench size across flats	S ₁	10	13
Wrench size across flats	S ₂	30	36
Weight	ca. kg	11.2	14.0

Dimensions in mm.

Fill Cluster

Flow rate Fill Cluster



Flow rates of the Fill Cluster

Typ 070XX - Standard design	Technical data			
	Nominal size	DN	25	40
Kvs-Value both-sided open	m ³ /h	36.5	60.0	
Kvs-Value one-sided open	m ³ /h	18.0	33.0	
Kvs-Value both-sided open with check function	m ³ /h	32.5	50.5	
Kvs-Value one-sided open with check function	m ³ /h	17.0	29.0	
Kvs-Value both-sided open with screen	m ³ /h	27.0	37.0	
Kvs-Value one-sided open with screen	m ³ /h	13.5	18.5	
Kvs-Value both-sided open with check function and screen	m ³ /h	21.0	27.0	
Kvs-Value one-sided open with check function and screen	m ³ /h	12.5	15.5	
Cv-Value both-sided open	gal/min	42.0	69.5	
Cv-Value one-sided open	gal/min	21.0	38.5	
Cv-Value both-sided open with check function	gal/min	38.0	58.5	
Cv-Value one-sided open with check function	gal/min	20.0	33.5	
Cv-Value both-sided open with screen	gal/min	31.0	43.0	
Cv-Value one-sided open with screen	gal/min	15.5	21.5	
Cv-Value both-sided open with check function and screen	gal/min	24.0	31.0	
Cv-Value one-sided open with check function and screen	gal/min	14.5	18.0	

Spare Parts Valves and Fill Cluster

Type 28203 - Disc complete



for Cryogenic-Globe Valves

brass disc CW614N

"cleaned and degreased for oxygen service"

Part No. 28203.X.0000

suitable for:

Type	Nominal size
01301, 01311	DN10 - DN50
01305, 01315, 02401, 02411	DN10 - DN50
01331	DN10 - DN100
01321	DN10 - DN150
01332, 01322	DN10 - DN50
01335, 01325	DN10 - DN50
03331, 03321	DN25 - DN150

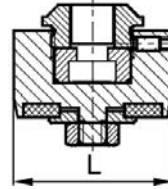

Type 28203.X.0000		Technical data											
Nominal size	DN	10	15	20	25	32	40	50	65	80	100	150	
Dimension code	.X.	0100	0150	0200	0250	0320	0400	0500	0650	0800	1000	1500	
Disc Ø	L	23	25	30	34.5	42	47	55	73	86	104	155	
Weight	ca. kg	0.05	0.06	0.09	0.12	0.18	0.22	0.30	0.55	0.75	1.05	3.10	

Dimensions in mm.

for Cryogenic-Globe Valves

stainless steel disc 1.4301

"cleaned and degreased for oxygen service"

Part No. 28203.X.0765

suitable for:

Type	Nominal size
01351	DN10 - DN100
01341	DN10 - DN200
01352, 01342	DN15 - DN50
01355, 01345	DN10 - DN50
03351, 03341	DN25 - DN150
01353	DN40 - DN80

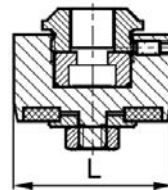

Type 28203.X.0765		Technical data											
Nominal size	DN	10	15	20	25	32	40	50	65	80	100	150	200
Dimension code	.X.	0100	0150	0200	0250	0320	0400	0500	0650	0800	1000	1500	2000
Disc Ø	L	23	25	30	34.5	42	47	55	73	86	104	155	217
Weight	ca. kg	0.05	0.06	0.09	0.12	0.18	0.22	0.30	0.55	0.75	1.05	3.10	9.28

Dimensions in mm.

Spare Parts Valves and Fill Cluster

Type 28203, Type 28205 - Check Disc complete



for Cryogenic-Globe/Check Valves
brass check disc CW614N
"cleaned and degreased for oxygen service"

Part No. 28203.X.5000

suitable for:

Type	Nominal size
01301, 01311	DN10 - DN50
01305, 01315, 02401, 02411	DN10 - DN50
01331	DN10 - DN100
01321	DN10 - DN150
01332, 01322, 01335, 01325	DN10 - DN50
03331, 03321	DN25 - DN150

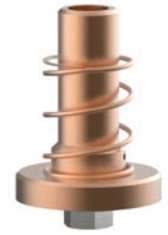
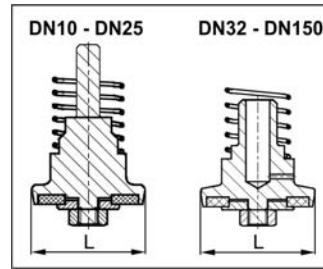

Type 28203.X.5000	Technical data											
Nominal size	DN	10	15	20	25	32	40	50	65	80	100	150
Dimension code	.X.	0100	0150	0200	0250	0320	0400	0500	0650	0800	1000	1500
Disc Ø	L	23	25	30	34.5	42	47	55	73	86	104	155
Weight	ca. kg	0.05	0.07	0.09	0.10	0.15	0.20	0.34	0.48	0.66	1.05	3.28

Dimensions in mm.

for Cryogenic-Globe/Check Valves
stainless steel check disc 1.4301
"cleaned and degreased for oxygen service"

Part No. 28205.X.5000

suitable for:

Type	Nominal size
01351	DN10 - DN100
01341	DN10 - DN150
01352, 01342	DN15 - DN50
01355, 01345	DN10 - DN50
03351, 03341	DN25 - DN150

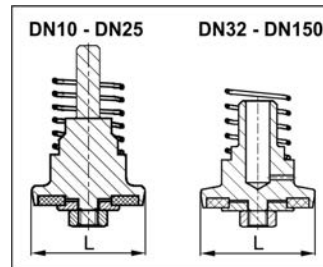

Type 28205.X.5000	Technical data											
Nominal size	DN	10	15	20	25	32	40	50	65	80	100	150
Dimension code	.X.	0100	0150	0200	0250	0320	0400	0500	0650	0800	1000	1500
Disc Ø	L	23	25	30	34.5	42	47	55	73	86	104	155
Weight	ca. kg	0.05	0.07	0.09	0.10	0.15	0.20	0.34	0.48	0.66	1.05	3.28

Dimensions in mm.

Spare Parts Valves and Fill Cluster

Type 29240 - Disc complete



for Cryogenic-Gate Valves

brass disc CW452K
 "cleaned and degreased for oxygen service"

Part No. 29240.X.0000

consisting of:
 1 x Disc complete (incl. disc seal PTFE/Carbon filled (25%))
 1 x Spring ring
 1 x Disc nut self locking

suitable for:

Type	Nominal size
09340, 09343	DN25 - DN100
09443	DN25 - DN65

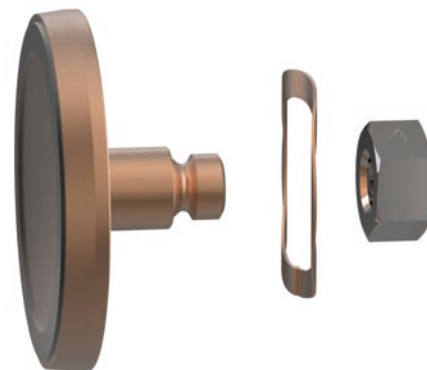

Materials	DIN EN	ASTM
1 Disc	CW452K	B 159 UNS C51900
2 Spring ring	1.4568	UNS 631
3 Nut	1.4301/A2 A 194 B8	
4 Valve seal	PTFE / Carbon filled (25%)	

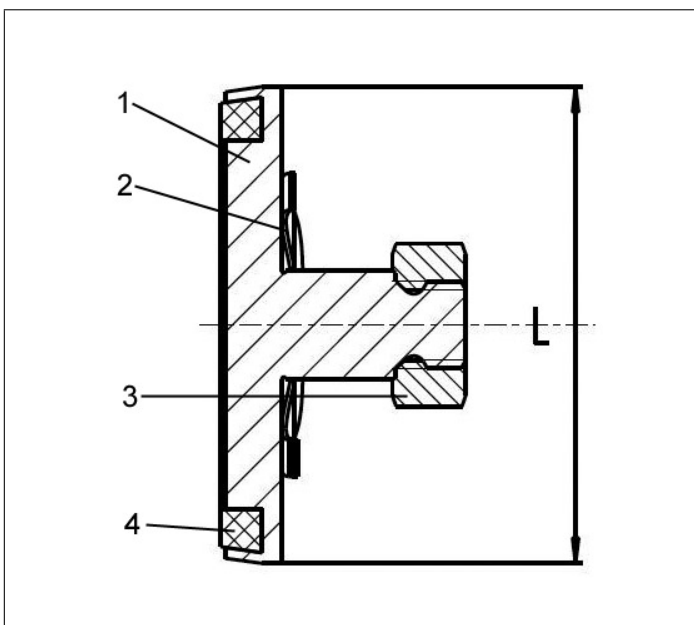

Type 29240	Technical data						
Nominal size	DN	25	40	50	65	80	100
Dimension code	.X.	0250	0400	0500	0650	0800	1000
Disc-Ø	L	34	44	55	70	78	107
Weight	ca. kg	0.05	0.08	0.15	0.18	0.20	0.56

Dimensions in mm.

Spare Parts Valves and Fill Cluster

Type 29256 - Wedge complete



for Cryogenic-Gate Valves

"cleaned and degreased for oxygen service"

Part No. 29256.X.0000

consisting of:

- 1 x Wedge
- 1 x Disc complete (incl. disc seal PTFE/Carbon filled (25%))
- 1 x Spring ring
- 1 x Disc nut self locking
- 1 x bearing bolt

suitable for:

Type	Nominal size
09340, 09343	DN25 - DN100
09443	DN25 - DN65



Materials	DIN EN	ASTM
1 Wedge	1.4308	A 351 CF8
2 Disc	CW452K	B 159 UNS C51900
3 Spring ring	1.4568	UNS 631
4 Nut	1.4301/A2	A 194 B8
5 Valve seal	PTFE / Carbon filled (25%)	
6 Bearing bolt	1.4301	A 276 Grade 304

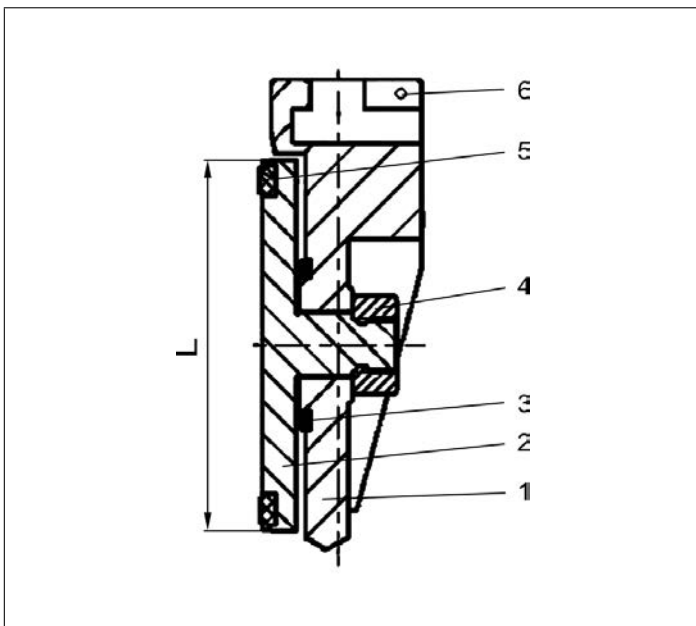

Type 29256	Technical data						
Nominal size	DN	25	40	50	65	80	100
Dimension code	.X.	0250	0400	0500	0650	0800	1000
Disc-Ø	L	34	45	55	70	78	108
Weight	ca. kg	0.21	0.33	0.57	0.74	1.06	2.13

Dimensions in mm.

Edition 2016-01

Spare Parts Valves and Fill Cluster

Type 28301 - Topwork



for Cryogenic-Globe and Globe/Check Valves

Bronze topwork
 "live loaded" gland packing
 "cleaned and degreased for oxygen service"

Part No. 28301.X.0000

Part No. 28301.X.5000 with check function



suitable for:

Type	Nominal size
01301, 01305, 02401	DN10 - DN50
01331	DN10 - DN100
01335	DN10 - DN50
03331	DN25 - DN150

Materials	DIN EN	ASTM
1 Valve seal	PTFE / Carbon filled (25%)	
2 Disc	CW614N B 283 UNS C38500	
3 Bonnet gasket	PTFE	
4 Headpiece	CC493K B 505 UNS C93200	
5 Bolts	1.4301/A2 A 194 B8	
6 Stem	1.4301 A 276 Grade 304	
7 Gland packing	Graphite / PTFE	
8 Gland nut	CW614N B 283 UNS C38500	
9 Handwheel	Aluminium alloy	
10 Spring	CW452K B 159 UNS C51900	

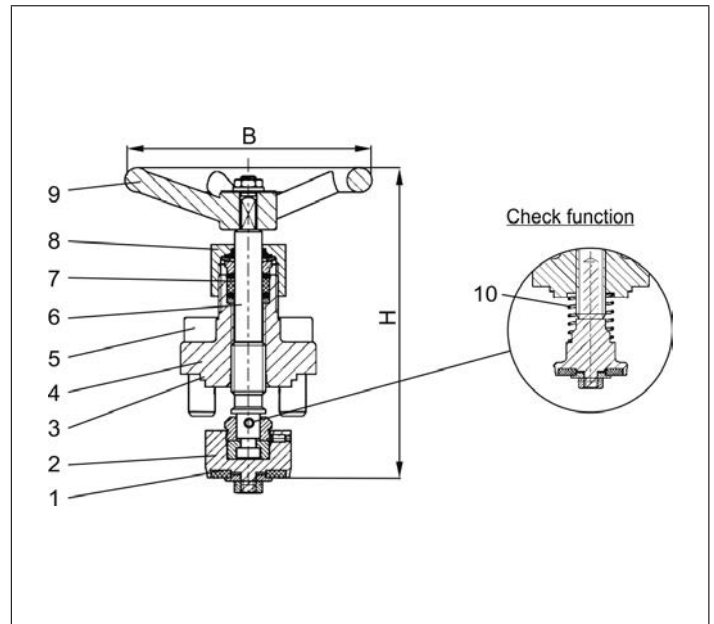

Type 28301	Technical data											
	DN	10	15	20	25	32	40	50	65	80	100	150
Nominal size	DN	10	15	20	25	32	40	50	65	80	100	150
Dimension code	.X.	0100	0150	0200	0250	0320	0400	0500	0650	0800	1000	1500
Height	H	130	130	130	130	155	160	185	240	285	320	380
Number of bolts		4	4	4	4	4	4	6	6	6	6	12
Handwheel-Ø	B	100	100	100	100	125	125	125	200	250	315	360
Weight	ca. kg	0.6	0.7	0.95	1.0	1.5	1.9	2.7	4.8	5.9	8.4	18.0

Dimensions in mm.

Spare Parts Valves and Fill Cluster

Type 28351 - Topwork



for Cryogenic-Globe and Globe/Check Valves

Stainless steel topwork,
 "live loaded" gland packing
 "cleaned and degreased for oxygen service"

Part No. 28351.X.0000

Part No. 28351.X.5000 with check function



suitable for:

Type	Nominal size
01351	DN10 - DN100
01355	DN10 - DN50
03351	DN25 - DN150

Materials	DIN EN	ASTM
1 Valve seal	PTFE / Carbon filled (25%)	
2 Disc	1.4301	A 276 Grade 304
3 Bonnet gasket	PTFE	
4 Headpiece	1.4301 / 1.4308	A 276 Grade 304 / A 351 CF8
5 Bolts	1.4301/A2	A 194 B8
6 Stem	1.4301	A 276 Grade 304
7 Gland packing	Graphite / PTFE	
8 Gland nut	1.4305	A 276 Grade 303
9 Handwheel	Aluminium alloy	
10 Spring	1.4310	A 313 Grade 301
11 Bush	CW452K	B 159 UNS C51900

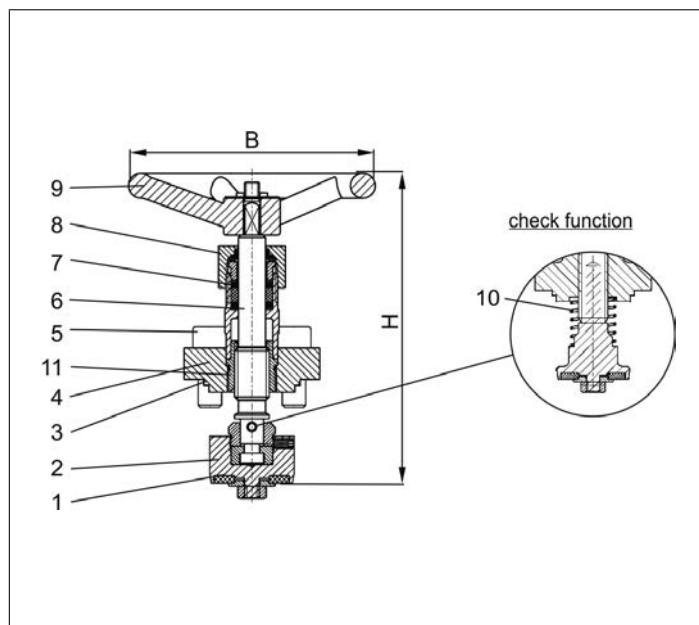

Type 28351	Technical data											
Nominal size	DN	10	15	20	25	32	40	50	65	80	100	150
Dimension code	.X.	0100	0150	0200	0250	0320	0400	0500	0650	0800	1000	1500
Height	H	130	130	130	130	155	160	185	240	285	320	380
Number of bolts		4	4	4	4	4	4	6	6	6	6	12
Handwheel-Ø	B	100	100	100	100	125	125	125	200	250	315	360
Weight	ca. kg	0.6	0.7	0.95	1.0	1.5	1.9	2.7	4.8	5.9	8.4	18.0

Dimensions in mm.

Edition 2016-01

Spare Parts Valves and Fill Cluster

Type 28311 - Topwork



for Cryogenic-Globe and Globe/Check Valves

Bronze topwork
 "live loaded" gland packing
 "cleaned and degreased for oxygen service"

Part No. 28311.X.0010 (H=270mm)

Part No. 28311.X.0020 (H=370mm)

Part No. 28311.X.5010 (H=270mm) with check function

Part No. 28311.X.5020 (H=370mm) with check function

suitable for:

Type	Nominal size
01311, 01315, 02411	DN10 - DN50
01321	DN10 - DN150
01325	DN10 - DN50
03321	DN25 - DN150
07003 - only drain valve	DN15
07004 - only drain valve	DN15

Materials	DIN EN	ASTM
1 Valve seal	PTFE / Carbon filled (25%)	
2 Disc	CW614N B 283 UNS C38500	
3 Bonnet gasket	PTFE	
4 Headpiece	CC493K B 505 UNS C93200	
5 Bolts	1.4301/A2 A 194 B8	
6 Elongation tube	1.4541 A 213 TP 321	
7 Stem	1.4301 A 276 Grade 304	
8 Gland packing	Graphite / PTFE	
9 Gland nut	CW614N B 283 UNS C38500	
10 Handwheel	Aluminium alloy	
11 Spring	CW452K B 159 UNS C51900	

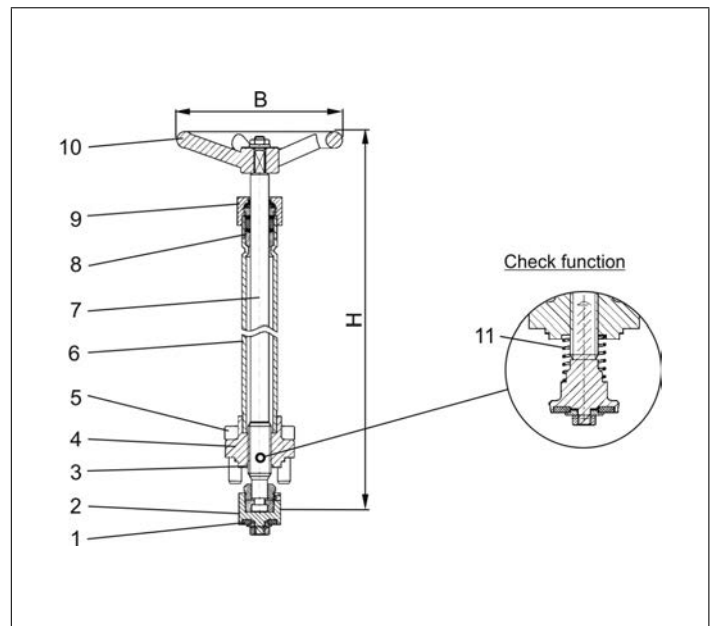

Type 28311	Technical data											
Nominal size	DN	10	15	20	25	32	40	50	65	80	100	150
Dimension code	.X.	0100	0150	0200	0250	0320	0400	0500	0650	0800	1000	1500
Height	H	270 mm or 370 mm							400	400	400	420
Number of bolts		4	4	4	4	4	4	6	6	6	6	6
Handwheel-Ø	B	100	100	100	100	125	125	125	200	250	315	350
Weight	ca. kg	1.0	1.1	1.4	1.4	2.0	2.4	3.0	5.5	6.8	9.5	18.4

Dimensions in mm.

Spare Parts Valves and Fill Cluster

Type 28341 - Topwork



for Cryogenic-Globe and Globe/Check Valves

Stainless steel topwork,
 "live loaded" gland packing
 "cleaned and degreased for oxygen service"

Part No. 28341.X.0010 (H=270mm)

Part No. 28341.X.0020 (H=370mm)

Part No. 28341.X.5010 (H=270mm) with check function

Part No. 28341.X.5020 (H=370mm) with check function

suitable for:

Type	Nominal size
01341	DN10 - DN200
01345	DN10 - DN50
03341	DN25 - DN150



Materials	DIN EN	ASTM
1 Valve seal	PTFE / Carbon filled (25%)	
2 Disc	1.4301	A 276 Grade 304
3 Bonnet gasket	PTFE	
4 Headpiece	1.4301 / 1.4308	A 276 Grade 304 / A 351 CF8
5 Bolts	1.4301/A2	A 194 B8
6 Elongation tube	1.4541	A 213 TP 321
7 Stem	1.4301	A 276 Grade 304
8 Gland packing	Graphite / PTFE	
9 Gland nut	1.4305	A 276 Grade 303
10 Handwheel	Aluminium alloy	
11 Spring	1.4310	A 313 Grade 301
12 Bush	CW452K	B 159 UNS C51900

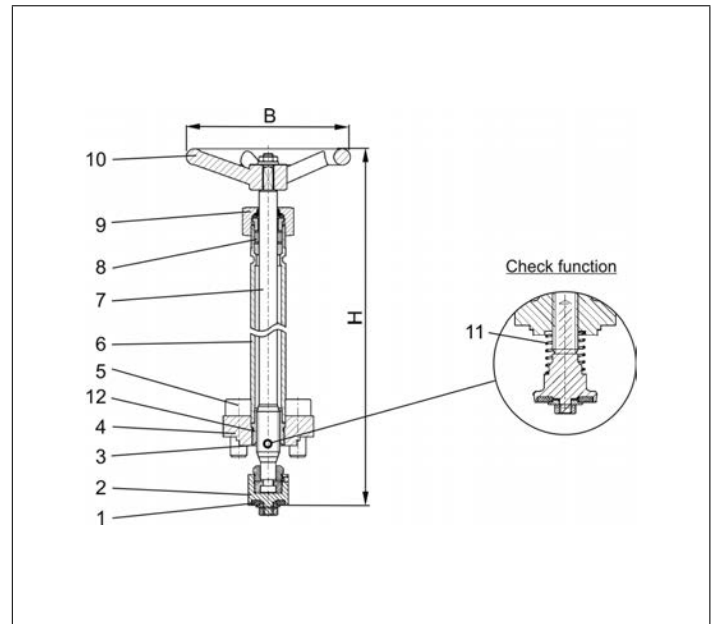

Type 28341	Technical data												
Nominal size	DN	10	15	20	25	32	40	50	65	80	100	150	200
Dimension code	.X.	0100	0150	0200	0250	0320	0400	0500	0650	0800	1000	1500	2000
Height	H	270 mm or 370 mm							400	400	400	420	560
Number of bolts		4	4	4	4	4	4	6	6	6	6	6	12
Handwheel-Ø	B	100	100	100	100	125	125	125	200	250	315	350	630
Weight	ca. kg	1.0	1.1	1.4	1.4	2.0	2.4	3.0	5.5	6.8	9.5	18.4	56.8

Dimensions in mm.

Spare Parts Valves and Fill Cluster

Type 28302 - Topwork Angle Type



for Cryogenic-Globe Valves Angle Type

Bronze topwork,
 "live loaded" gland packing
 "cleaned and degreased for oxygen service"

Part No. 28302.X.0000

suitable for:

Type	Nominal size
01332	DN15 - DN50



Materials	DIN EN	ASTM
1 Valve seal	PTFE / Carbon filled (25%)	
2 Disc	CW614N B 283 UNS C38500	
3 Bonnet gasket	PTFE	
4 Headpiece	CC493K B 505 UNS C93200	
5 Bolts	1.4301/A2 A 194 B8	
6 Stem	1.4301 A 276 Grade 304	
7 Gland packing	Graphite / PTFE	
8 Gland nut	CW614N B 283 UNS C38500	
9 Handwheel	Aluminium alloy	

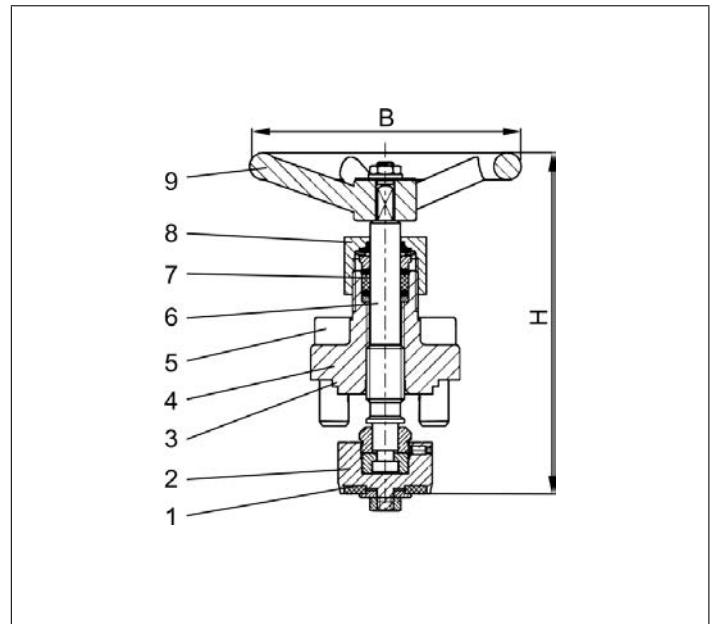

Type 28302	Technical data							in preparation	
	DN	15	20	25	32	40	50	80	100
Nominal size	DN	15	20	25	32	40	50	80	100
Dimension code	.X.	0150	0200	0250	0320	0400	0500	-	-
Height	H	130	130	130	155	160	185	-	-
Number of bolts		4	4	4	4	4	6	-	-
Handwheel-Ø	B	100	100	100	125	125	125	-	-
Weight	ca. kg	0.7	0.95	1.0	1.5	1.9	2.7	-	-

Dimensions in mm.

Spare Parts Valves and Fill Cluster

Type 28352 - Topwork Angle Type



for Cryogenic-Globe Valves Angle Type

Stainless steel topwork,
 "live loaded" gland packing
 "cleaned and degreased for oxygen service"

Part No. 28352.X.0000

suitable for:

Type	Nominal size
01352	DN15 - DN50



Materials	DIN EN	ASTM
1 Valve seal	PTFE / Carbon filled (25%)	
2 Disc	1.4301	A 276 Grade 304
3 Bonnet gasket	PTFE	
4 Headpiece	1.4301 / 1.4308	A 276 Grade 304 / A 351 CF8
5 Bolts	1.4301/A2	A 194 B8
6 Stem	1.4301	A 276 Grade 304
7 Gland packing	Graphite / PTFE	
8 Gland nut	1.4305	A 276 Grade 303
9 Handwheel	Aluminium alloy	
10 Bush	CW452K	B 159 UNS C51900

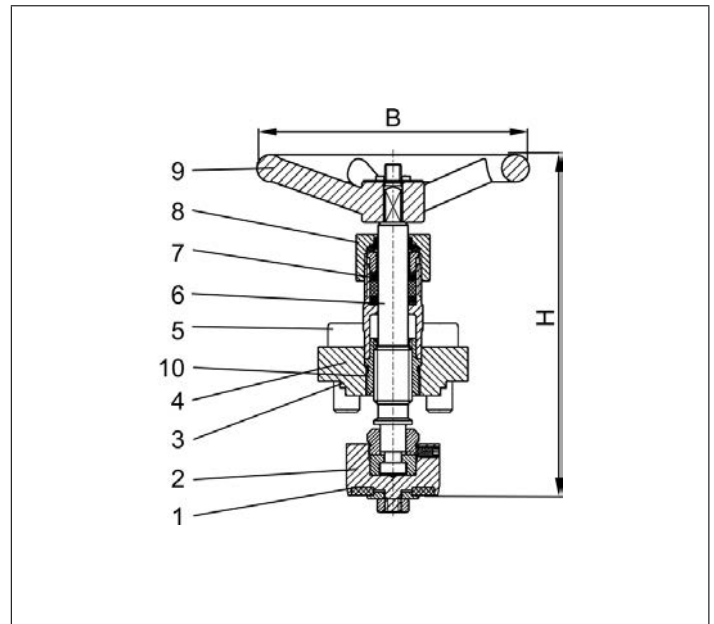

Type 28352	Technical data							in preparation	
Nominal size	DN	15	20	25	32	40	50	80	100
Dimension code	.X.	0150	0200	0250	0320	0400	0500	-	-
Height	H	130	130	130	155	160	185	-	-
Number of bolts		4	4	4	4	4	6	-	-
Handwheel-Ø	B	100	100	100	125	125	125	-	-
Weight	ca. kg	0.7	0.95	1.0	1.5	1.9	2.7	-	-

Dimensions in mm.

Spare Parts Valves and Fill Cluster

Type 28312 - Topwork Angle Type



for Cryogenic-Globe Valves Angle Type

Bronze topwork
 "live loaded" gland packing
 "cleaned and degreased for oxygen service"

Part No. 28312.X.0010 (H=270mm)

Part No. 28312.X.0020 (H=370mm)

Part No. 28312.X.5010 (H=270mm) with check function

Part No. 28312.X.5020 (H=370mm) with check function

suitable for:

Type	Nominal size
01322	DN15 - DN50
07003 - only angled valves	DN25 & DN40
07004 - only angled valves	DN25 & DN40
07015 - only angled valves	DN25 & DN40



Materials	DIN EN	ASTM
1 Valve seal	PTFE / Carbon filled (25%)	
2 Disc	CW614N B 283 UNS C38500	
3 Bonnet gasket	PTFE	
4 Headpiece	CC493K B 505 UNS C93200	
5 Bolts	1.4301/A2 A 194 B8	
6 Elongation tube	1.4541 A 213 TP 321	
7 Stem	1.4301 A 276 Grade 304	
8 Gland packing	Graphite / PTFE	
9 Gland nut	CW614N B 283 UNS C38500	
10 Handwheel	Aluminium alloy	
11 Spring	CW452K B 159 UNS C51900	

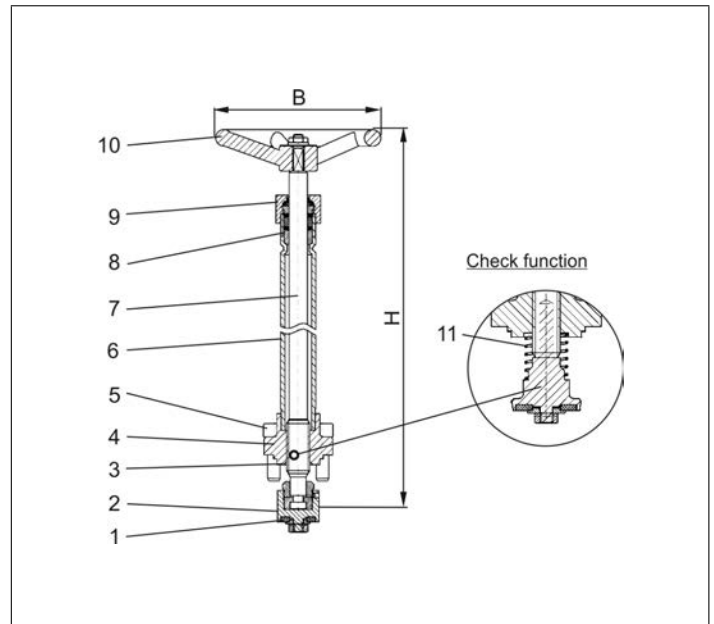

Type 28312	Technical data							in preparation		
	DN	15	20	25	32	40	50	80	100	
Nominal size	.X.	0150	0200	0250	0320	0400	0500	-	-	
Dimension code										
Height	H	270 mm or 370 mm								
Number of bolts		4	4	4	4	4	6	-	-	
Handwheel-Ø	B	100	100	100	125	125	125	-	-	
Weight	ca. kg	1.1	1.4	1.4	2.0	2.4	3.0	-	-	

Dimensions in mm.

Spare Parts Valves and Fill Cluster

Type 28342 - Topwork Angle Type



for Cryogenic-Globe Valves Angle Type

Stainless steel topwork,
 "live loaded" gland packing
 "cleaned and degreased for oxygen service"

Part No. 28342.X.0010 (H=270mm)

Part No. 28342.X.0020 (H=370mm)

suitable for:

Type	Nominal size
01342	DN15 - DN50
07017	DN25 & DN40



Materials	DIN EN	ASTM
1 Valve seal	PTFE / Carbon filled (25%)	
2 Disc	1.4301	A 276 Grade 304
3 Bonnet gasket	PTFE	
4 Headpiece	1.4301 / 1.4308	A 276 Grade 304 / A 351 CF8
5 Bolts	1.4301/A2	A 194 B8
6 Elongation tube	1.4541	A 213 TP 321
7 Stem	1.4301	A 276 Grade 304
8 Gland packing	Graphite / PTFE	
9 Gland nut	1.4305	A 276 Grade 303
10 Handwheel	Aluminium alloy	
11 Bush	CW452K	B 159 UNS C51900

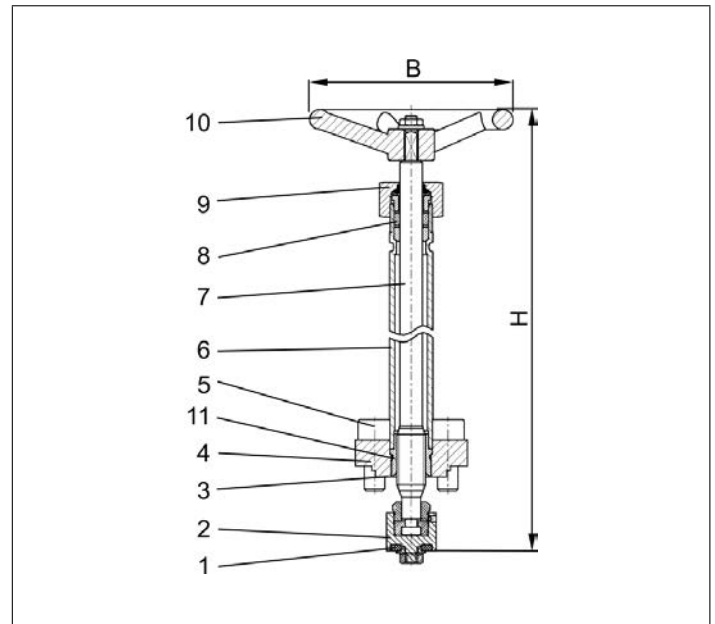

Type 28342	Technical data							in preparation		
Nominal size	DN	15	20	25	32	40	50	80	100	
Dimension code	.X.	0150	0200	0250	0320	0400	0500	-	-	
Height	H	270 mm or 370 mm							-	-
Number of bolts		4	4	4	4	4	6	-	-	
Handwheel-Ø	B	100	100	100	100	125	125	-	-	
Weight	ca. kg	1.1	1.4	1.4	2.0	2.4	3.0	-	-	

Dimensions in mm.

Spare Parts Valves and Fill Cluster

Type 29340 - Topwork



for Cryogenic-Gate Valves

Stainless steel topwork,
 one way tightening (in flow direction),
 "live loaded" gland packing
 "cleaned and degreased for oxygen service"

Part No. 29340.0400.0010 (DN40)

Part No. 29340.X.0020

suitable for:

Type	Nominal size
09340	DN25 - DN100



Materials	DIN EN	ASTM
1 Valve seal	PTFE / Carbon filled (25%)	
2 Disc	CW452K B 159 UNS C51900	
3 Wedge	1.4308	A 351 CF8
4 Stem	1.4301	A 276 Grade 304
5 Bonnet gasket	PTFE	
6 Headpiece	1.4308	A 351 CF8
7 Bolts	1.4301/A2	A 194 B8
8 Elongation tube	1.4541	A 213 TP 321
9 Gland packing	Graphite / PTFE	
10 Gland nut	1.4305	A 276 Grade 303
11 Handwheel	Aluminium alloy	
12 Bush	CW452K B 159 UNS C51900	

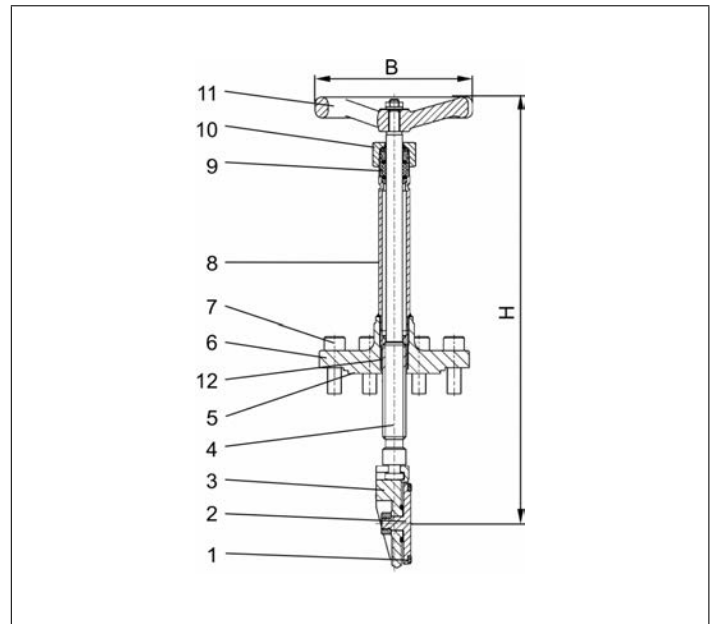

Type 29340	Technical data						
Nominal size	DN	25	40	50	65	80	100
Dimension code	.X.	0250	0400	0500	0650	0800	1000
Height	H	300/400	320/420	360	370	380	470/570
Number of bolts		4	4	6	8	6	8
Handwheel-Ø	B	125	125	150	150	150	200
Weight	ca. kg	2.0	2.3	3.6	4.2	5.5	10.4

Dimensions in mm.

Spare Parts Valves and Fill Cluster Type 30000 - Sealing spare part kit



for Cryogenic-Globe Valves

"cleaned and degreased for oxygen service"

Part No. 30000.X.0000

consisting of:

- 2x Bonnet gasket PTFE
- 1x Disc seal PTFE/Carbon filled (25%)
- 1x Disc nut 1.4301
- 1x Stem sealing kit complete PTFE/Graphite

suitable for:

Type	Nominal size
01301, 01311	DN10 - DN50
01305, 01315, 02401, 02411	DN10 - DN50
01321, 01331	DN10 - DN150
01332, 01322	DN10 - DN50
01335, 01325	DN10 - DN50
01353	DN15 - DN80
03331, 03321	DN25 - DN150

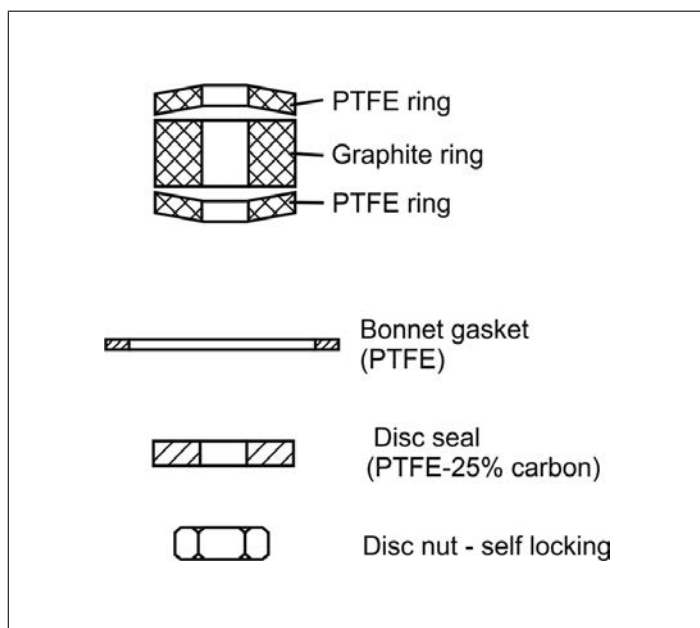

Type 30000	Technical data											
Nominal size	DN	10	15	20	25	32	40	50	65	80	100	150
Dimension code	.X.	0100	0150	0200	0250	0320	0400	0500	0650	0800	1000	1500
Weight	ca. kg	0.03	0.03	0.04	0.05	0.07	0.08	0.12	0.17	0.23	0.31	0.35

Dimensions in mm.

Edition 2016-01

Spare Parts Valves and Fill Cluster

Type 30290 - Sealing spare part kit



for Cryogenic-Gate Valves

"cleaned and degreased for oxygen service"

Part No. 30290.X.S000

consisting of:

- 2x Bonnet gasket PTFE
- 1x Gland packing kit complete PTFE/Graphite

suitable for:

Type	Nominal size
09340, 09345, 09440	DN25 - DN100

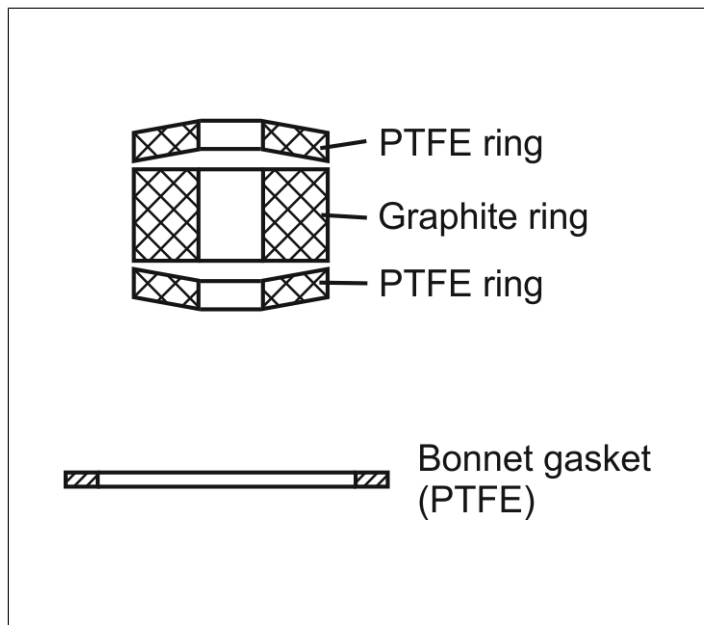
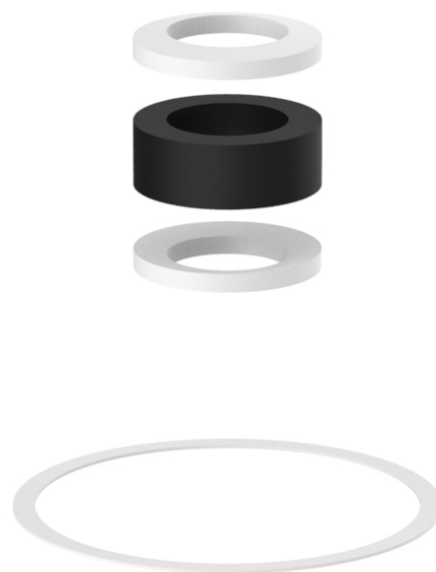

Type 30290	Technical data						
Nominal size	DN	25	40	50	65	80	100
Dimension code	.X.	0250	0400	0500	0650	0800	1000
Weight	ca. kg	0.02	0.05	0.10	0.15	0.21	0.29

Dimensions in mm.

Spare Parts Valves and Fill Cluster Type 30293 - Sealing spare part kit



for actuated Cryogenic-Gate Valves

"cleaned and degreased for oxygen service"

Part No. 30293.X.S000

consisting of:

- 2x Bonnet gasket PTFE
- 1x Gland packing kit complete PTFE/Graphite
- 2x Stem gasket Mica

suitable for:

Type	Nominal size
09343	DN25 - DN100
09443	DN25 - DN65

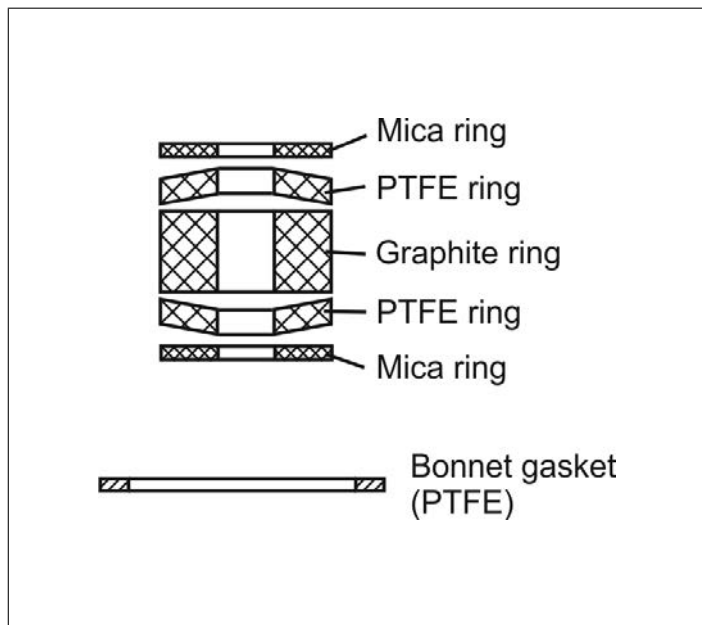
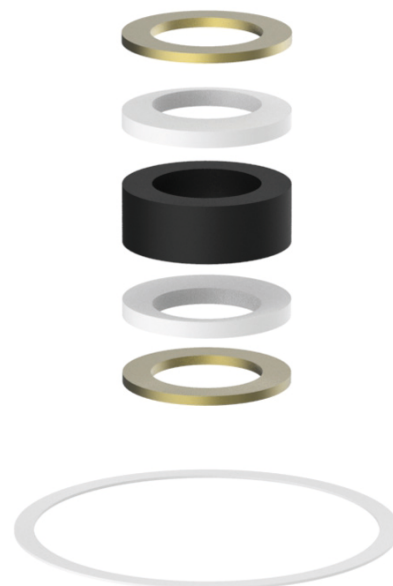

Type 30293	Technical data						
Nominal size	DN	25	40	50	65	80	100
Dimension code	.X.	0250	0400	0500	0650	0800	1000
Weight	ca. kg	0.03	0.06	0.11	0.16	0.22	0.30

Dimensions in mm.

Edition 2016-01

Spare Parts Valves and Fill Cluster Type 30341 - Sealing spare part kit



for Cryogenic-Globe Valves

"cleaned and degreased for oxygen service"

Part No. 30341.X.0000

consisting of:

- 2x Bonnet gasket PTFE
- 1x Disc seal PTFE/Carbon filled (25%)
- 1x Disc nut 1.4301
- 1x Gland packing kit complete PTFE/Graphite
- 2x Stem gasket Mica

suitable for:

Type	Nominal size
01351	DN10 - DN100
01341	DN10 - DN200
01352, 01342	DN15 - DN50
01355, 01345	DN10 - DN50
03351, 03341	DN25 - DN150

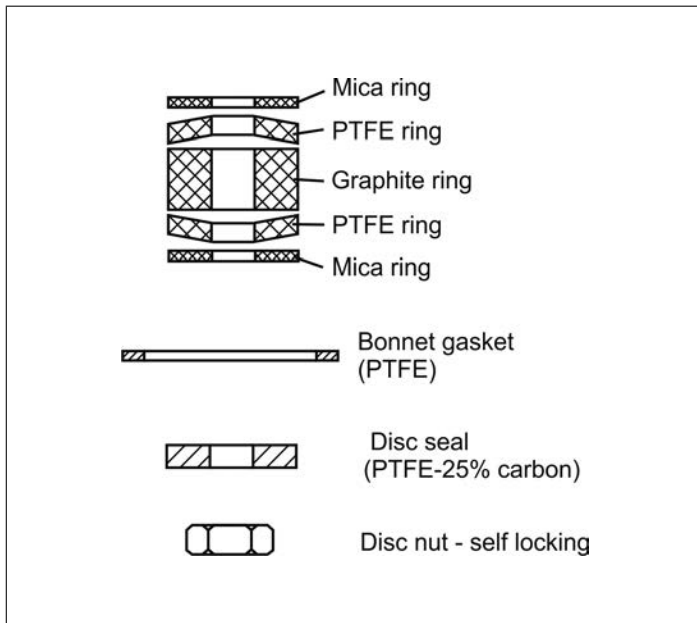

Type 30341	Technical data												
	DN	10	15	20	25	32	40	50	65	80	100	150	200
Dimension code	.X.	0100	0150	0200	0250	0320	0400	0500	0650	0800	1000	1500	2000
Weight	ca. kg	0.03	0.03	0.04	0.05	0.07	0.08	0.13	0.18	0.24	0.32	0.68	1.91

Dimensions in mm.

Spare Parts Valves and Fill Cluster

Type 31514 - KEL-F (PCTFE) Disc sealing spare part kit



for Cryogenic Globe Valves and Check Valves

"cleaned and degreased for oxygen service"

Part No. 31514.X.PCTFE

consisting of:

- 2x Bonnet gasket PTFE
- 1x Disc seal KEL-F (PCTFE)
- 1x Disc nut 1.4301

suitable for:

Type	Nominal size
01301, 01311	DN10 - DN50
01305, 01315, 02401, 02411	DN10 - DN50
01331	DN10 - DN100
01321	DN10 - DN100
01332, 01322	DN10 - DN50
01335, 01325	DN10 - DN50
03331, 03321	DN25 - DN150
01351	DN10 - DN100
01341	DN10 - DN100
01352, 01342	DN15 - DN50
01355, 01345	DN10 - DN50
03351, 03341	DN25 - DN150

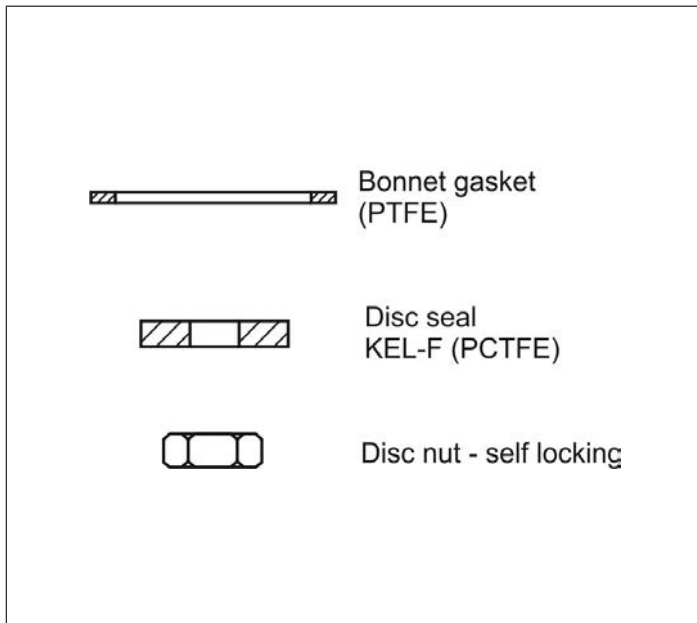

Type 31514	Technical data											
	DN	10	15	20	25	32	40	50	65	80	100	150
Dimension code	.X.	0100	0150	0200	0250	0320	0400	0500	0650	0800	1000	1500
Weight	ca. kg	0.02	0.02	0.03	0.04	0.06	0.07	0.11	0.16	0.22	0.30	0.40

Dimensions in mm.

Spare Parts Valves and Fill Cluster

Typ 55318, Typ 55317 - Handrad



for Cryogenic Globe Valves

Aluminium Handwheels

Part No.	Nominal size Globe Valve	colour
55318.0001.0402	DN10 - DN25	white (RAL 9010)
55318.0002.0402	DN32 - DN50	white (RAL 9010)

Part No.	Nominal size Globe Valve	colour
55317.0021.0402	DN65	silver (natural)
55317.0022.0402	DN80	silver (natural)
55317.0068.0402	DN100	silver (natural)
55317.0016.0402	DN150	silver (natural)
55317.0106.0402	DN200	silver (natural)



for Cryogenic Bellow sealed Valves

Part No.	Nominal size Bellow sealed Valve	colour
55317.0029.0402	DN10 - DN50	silver (natural)

for Cryogenic Gate Valves

Part No.	Nominal size Gate Valve	colour
55318.0002.0402	DN25 - DN40	white (RAL 9010)
55317.0029.0402	DN50 - DN80	silver (natural)
55317.0020.0402	DN100	silver (natural)



Handwheels (available colours) for Cryogenic Globe Valves DN10 - DN50

Part No.	Nominal size	colour
55318.0016.0402	DN10 - DN25	silver (natural)
55318.0017.0402	DN32 - DN50	silver (natural)



Part No.	Nominal size	colour
55318.0004.0402	DN10 - DN25	red (RAL 3000)
55318.0005.0402	DN32 - DN50	red (RAL 3000)



Part No.	Nominal size	colour
55318.0007.0402	DN10 - DN25	blue (RAL 5015)
55318.0008.0402	DN32 - DN50	blue (RAL 5015)

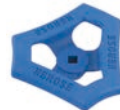

Part No.	Nominal size	colour
55318.0010.0402	DN10 - DN25	green (RAL 6005)
55318.0011.0402	DN32 - DN50	green (RAL 6005)

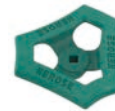

Part No.	Nominal size	colour
55318.0013.0402	DN10 - DN25	black (RAL 9011)
55318.0014.0402	DN32 - DN50	black (RAL 9011)

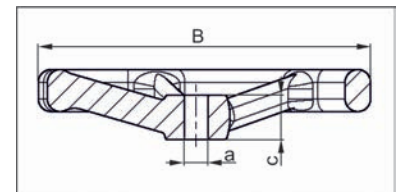

Type 55318	Technical data				Type 55317								
		.0001.0402	.0002.0402										
		.0004.0402	.0005.0402										
		.0007.0402	.0008.0402		.0016.0402	.0020.0402	.0021.0402	.0022.0402	.0029.0402	.0068.0402	.0106.0402		
		.0010.0402	.0011.0402										
		.0013.0402	.0014.0402										
		.0016.0402	.0017.0402										
Handwheel-Ø	B	100	125		360	200	200	250	150	315	630		
Square	a	7	10		15	12	10	10	10	12	27		
Hub height	c	15	19.5		35.0	30.0	20.5	20.0	19.0	33.0	56.0		
Weight	ca. kg	0.1	0.15		3.4	0.85	0.8	0.15	0.35	2.5	9.7		

Dimensions in mm.

Spare Parts Valves and Fill Cluster

Type 55579 - Valve locking



for Cryogenic-Globe Valves

Valve locking in vinyl

for protection against damage and unauthorized access.

locking with locking wire or padlock (shackle thickness max. 7.7mm) - not included

temperature range: -30°C up to +300°C

Part No. 55579.0005.0841

for handwheel diameter 60mm - 130mm

Part No. 55579.0006.0841

for handwheel diameter 131mm - 165mm

Part No. 55579.0007.0841

for handwheel diameter 166mm - 250mm

Part No. 55579.0008.0841

for handwheel diameter 251mm - 330mm



Available options - on request only:

- other colours
- additional sizes

Important: Please specify the diameter of handwheel when ordering.



Ball Valves

Type 15070, Type 15071 - Ball Valve full bore



3-Piece-Ball Valve

Stainless steel body and topwork, carbon steel handle
"live loaded" gland packing

Part No. 15070.X.0000

Socket weld connection for stainless steel pipes acc. to ISO 1127

Part No. 15071.X.0000

Butt weld connection for stainless steel pipes acc. to ISO 1127

Available options - on request only:

- End connection for pipes acc. to ASTM A312 S10/S40
- Stainless steel lockable handle
- With pneumatic actuator
- With upstream pressure relief hole
- ATEX Ex II 2GD



Applications:

Approved for air gases, vapours and gases.

Working temperature: -50°C / -58°F (223K) up to +190°C / +374°F (463K)

Materials	DIN EN	ASTM
1 Body	1.4409	CF3M (316L)
2 Ball seat	TFM 1600	
3 Ball	1.4409	CF3M (316L)
4 Fitting	1.4404	316L
5 Flange	1.4306	304L
6 Stem	1.4404	316L
8 Gland packing up to DN50	33% C + 2% Gr PTFE	
8a Gland packing from DN65	PTFE	
9 Lever	1.1181	1035

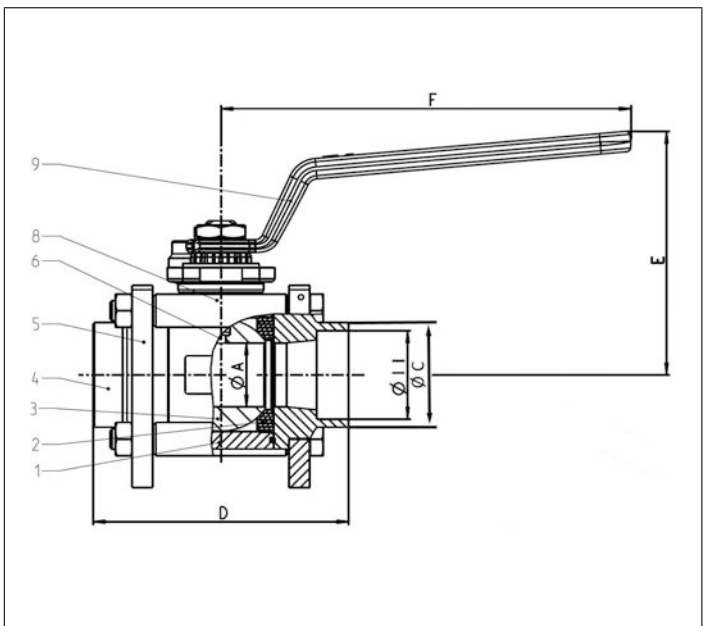

Standard marking acc. to Pressure Equipment Directive 97/23/EC (PED).



Type 15070, 15071	Technical data													
Nominal size	DN	8	12	15	20	25	32	40	50	65	80	100	125	150
Dimension code	.X.	0813	1217	1521	2026	2533	3242	4048	5060	6576	8088	0114	0141	0168
Nominal pressure	PN	100	100	100	100	70	70	50	50	40	40	25	25	16
Face-to-face dimension	D	65	65	70	80	100	110	125	150	180	210	230	260	290
Height	E	70	70	73	91	95	111	116	137	171	182	204	246	270
Outside pipe-Ø ISO 1127	Ø C	13.5	17.2	21.3	26.9	33.7	42.4	48.3	60.3	76.1	88.9	114.3	139.7	168.3
Wall thickness pipe ISO 1127	a	2.0	2.0	2.0	2.0	2.0	2.6	2.6	2.9	2.9	2.9	3.2	3.0	3.0
Pipe diameter SW	Ø I1	14.3	17.8	21.9	27.3	34.0	42.8	48.9	61.3	77.6	89.9	115.5	141.3	171.3
Orifice	Ø A	11.1	11.1	14.0	19.0	25.0	32.0	38.0	50.0	64.0	76.0	100.0	125.0	150.0
Length	F	120	120	120	160	160	190	190	230	370	440	505	710	710
Weight	ca. kg	0.65	0.65	0.81	1.61	2.11	3.32	4.27	8.64	14.89	22.75	34.35	57.12	80.04
Kvs-Value	m ³ /h	6.0	8.0	13.0	26.0	46.0	82.0	120.0	223.0	423.0	617.0	1154.0	1883.0	2844.0
Cv-Value	gal/min	6.9	9.2	15.0	30.0	53.2	94.8	138.7	257.8	489.0	713.3	1334.0	2176.7	3287.6

Dimensions in mm.

Ball Valves

Type 15072, Type 15073 - Ball Valve full bore



3-Piece-Ball Valve

Stainless steel body and topwork, carbon steel handle
"live loaded" gland packing

Part No. 15072.X.0000

Female thread NPT acc. to ANSI B 1.20.1

Part No. 15073.X.0000

Female thread G (BSPP) acc. to ISO 228/1

Available options - on request only:

- Stainless steel lockable handle
- With pneumatic actuator
- With upstream pressure relief hole
- ATEX Ex II 2GD



Applications:

Approved for air gases, vapours and gases.

Working temperature: -50°C / -58°F (223K) up to +190°C / +374°F (463K)

Materials	DIN EN	ASTM
1 Body	1.4409	CF3M (316L)
2 Ball seat	TFM 1600	
3 Ball	1.4409	CF3M (316L)
4 Fitting	1.4404	316L
5 Flange	1.4306	304L
6 Stem	1.4404	316L
8 Gland packing up to DN50	33% C + 2% Gr PTFE	
8a Gland packing from DN65	PTFE	
9 Lever	1.1181	1035

Standard marking acc. to Pressure Equipment Directive 97/23/EC (PED).

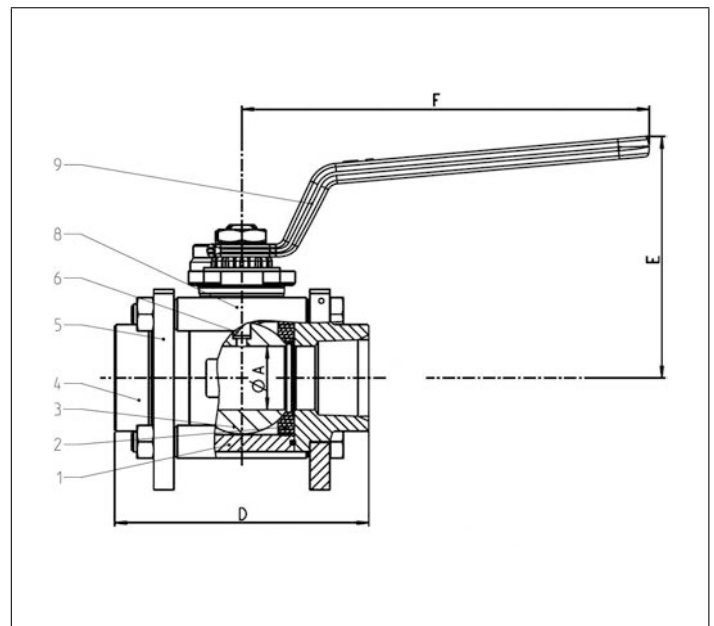

Type 15072, 15073	Technical data											
Nominal size	DN	8	12	15	20	25	32	40	50	65	80	100
Dimension code	.X.	0200	0300	0400	0600	1000	1200	1400	2000	2400	3000	4000
BSPP / NPT	threath	1/4"	3/8"	1/2"	3/4"	1"	1-1/4"	1-1/2"	2"	2-1/2"	3"	4"
Nominal pressure	PN	100	100	100	100	70	70	50	50	40	40	25
Face-to-face dimension	D	65	65	70	85	100	110	125	150	180	210	230
Height	E	70	70	73	91	95	111	116	137	171	182	204
Orifice	Ø A	11.1	11.1	14.0	19.0	25.0	32.0	38.0	50.0	64.0	76.0	100.0
Length	F	120	120	120	160	160	190	190	230	370	440	505
Weight	ca. kg	0.70	0.70	0.98	1.69	2.12	3.32	4.38	8.84	15.0	22.95	34.74
Kvs-Value	m ³ /h	6.0	8.0	13.0	26.0	46.0	82.0	120.0	223.0	423.0	617.0	1154.0
Cv-Value	gal/min	6.9	9.2	15.0	30.0	53.2	94.8	138.7	257.8	489.0	713.3	1334.0

Dimensions in mm.

Ball Valves

Type 15080, Type 15081 - Ball Valve full bore



Cryogenic-3-Piece-Ball Valve

Stainless steel body and topwork,
 "live loaded" gland packing
 "cleaned and degreased for oxygen service"
 with upstream pressure relief hole
 Marking acc. to EN 1626

Part No. 15080.X.0000

Socket weld connection for stainless steel pipes acc. to ISO 1127

Part No. 15081.X.0000

Butt weld connection for stainless steel pipes acc. to ISO 1127

Available options - on request only:

- End connection for pipes acc. to ASTM A312 S10/S40
- Stainless steel lockable handle
- With pneumatic actuator
- ATEX Ex II 2GD



Applications:

Approved for air gases, vapours and cryogenic liquefied gases.

Working temperature: -50°C / -58°F (223K) up to +190°C / +374°F (463K)

Materials	DIN EN	ASTM
1 Body	1.4409	CF3M (316L)
2 Ball seat	PTFE / Carbon filled (25%)	
3 Ball	1.4409	CF3M (316L)
4 Fitting	1.4404	316L
5 Flange	1.4306	304L
6 Stem	1.4404	316L
8 Gland packing up to DN50	33% C + 2% Gr PTFE	
8a Gland packing from DN65	PTFE	
9 Lever	1.1181	1035

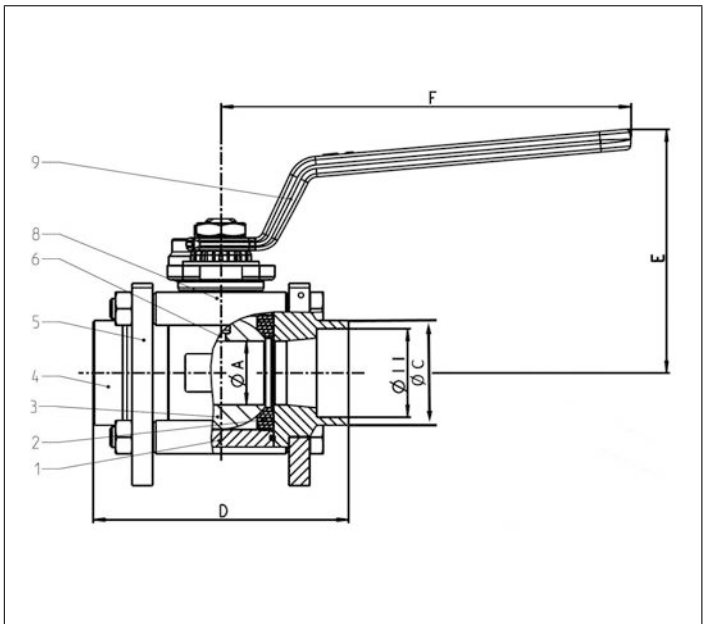

Standard marking acc. to Pressure Equipment Directive 97/23/EC (PED).



Type 15080, 15081	Technical data													
Nominal size	DN	8	12	15	20	25	32	40	50	65	80	100	125	150
Dimension code	.X.	0813	1217	1521	2026	2533	3242	4048	5060	6576	8088	0114	0141	0168
Nominal pressure	PN	100	100	100	100	70	70	50	50	40	40	25	25	16
Face-to-face dimension	D	65	65	70	80	100	110	125	150	180	210	230	260	290
Height	E	70	70	73	91	95	111	116	137	171	182	204	246	270
Outside pipe-Ø ISO 1127	Ø C	13.5	17.2	21.3	26.9	33.7	42.4	48.3	60.3	76.1	88.9	114.3	139.7	168.3
Wall thickness pipe ISO 1127	a	2.0	2.0	2.0	2.0	2.0	2.6	2.6	2.9	2.9	2.9	3.2	3.0	3.0
Pipe diameter SW	Ø I1	14.3	17.8	21.9	27.3	34.0	42.8	48.9	61.3	77.6	89.9	115.5	141.3	171.3
Orifice	Ø A	11.1	11.1	14.0	19.0	25.0	32.0	38.0	50.0	64.0	76.0	100.0	125.0	150.0
Length	F	120	120	120	160	160	190	190	230	370	440	505	710	710
Weight	ca. kg	0.65	0.65	0.81	1.61	2.11	3.32	4.27	8.64	14.89	22.75	34.35	57.12	80.04
Kvs-Value	m ³ /h	6.0	8.0	13.0	26.0	46.0	82.0	120.0	223.0	423.0	617.0	1154.0	1883.0	2844.0
Cv-Value	gal/min	6.9	9.2	15.0	30.0	53.2	94.8	138.7	257.8	489.0	713.3	1334.0	2176.7	3287.6

Dimensions in mm.

Ball Valves

Type 15082, Type 15083 - Ball Valve full bore



Cryogenic-3-Piece-Ball Valve

Stainless steel body and topwork,
 "live loaded" gland packing
 "cleaned and degreased for oxygen service"
 with upstream pressure relief hole
 Marking acc. to EN 1626

Part No. 15082.X.0000

Female thread NPT acc. to ANSI B 1.20.1

Part No. 15083.X.0000

Female thread G (BSPP) acc. to ISO 228/1

Available options - on request only:

- Stainless steel lockable handle
- With pneumatic actuator
- ATEX Ex II 2GD



Applications:

Approved for air gases, vapours and cryogenic liquefied gases.

Working temperature: -50°C / -58°F (223K) up to +190°C / +374°F (463K)

Materials	DIN EN	ASTM
1 Body	1.4409	CF3M (316L)
2 Ball seat	PTFE / Carbon filled (25%)	
3 Ball	1.4409	CF3M (316L)
4 Fitting	1.4404	316L
5 Flange	1.4306	304L
6 Stem	1.4404	316L
8 Gland packing up to DN50	33% C + 2% Gr PTFE	
8a Gland packing from DN65	PTFE	
9 Lever	1.1181	1035

Standard marking acc. to Pressure Equipment Directive 97/23/EC (PED).

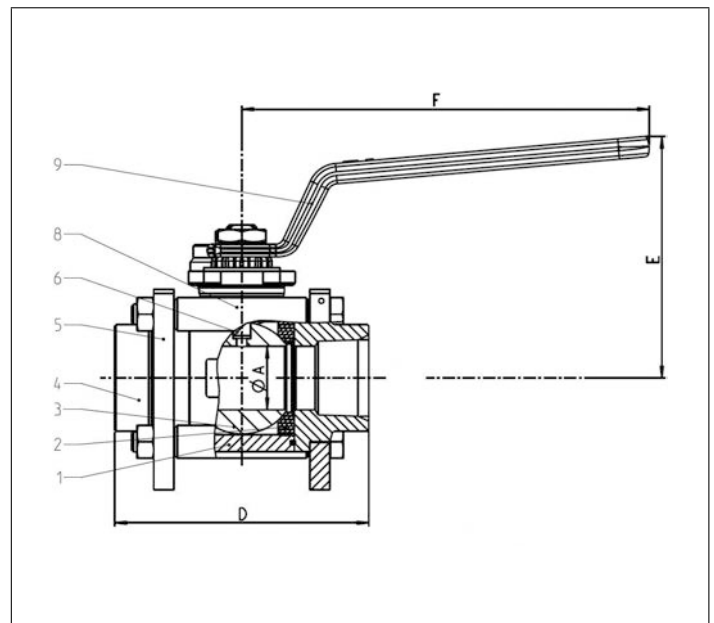

Type 15082, 15083	Technical data												
	DN	8	12	15	20	25	32	40	50	65	80	100	
Nominal size	.X.	0200	0300	0400	0600	1000	1200	1400	2000	2400	3000	4000	
Dimension code	.X.	0200	0300	0400	0600	1000	1200	1400	2000	2400	3000	4000	
BSPP / NPT	threath	1/4"	3/8"	1/2"	3/4"	1"	1-1/4"	1-1/2"	2"	2-1/2"	3"	4"	
Nominal pressure	PN	100	100	100	100	70	70	50	50	40	40	25	
Face-to-face dimension	D	65	65	70	85	100	110	125	150	180	210	230	
Height	E	70	70	73	91	95	111	116	137	171	182	204	
Orifice	Ø A	11.1	11.1	14.0	19.0	25.0	32.0	38.0	50.0	64.0	76.0	100.0	
Length	F	120	120	120	160	160	190	190	230	370	440	505	
Weight	ca. kg	0.70	0.70	0.98	1.69	2.12	3.32	4.38	8.84	15.0	22.95	34.74	
Kvs-Value	m ³ /h	6.0	8.0	13.0	26.0	46.0	82.0	120.0	223.0	423.0	617.0	1154.0	
Cv-Value	gal/min	6.9	9.2	15.0	30.0	53.2	94.8	138.7	257.8	489.0	713.3	1334.0	

Dimensions in mm.

Ball Valves

Type 15080, Type 15081 - Ball Valve full bore



Cryogenic-3-Piece-Ball Valve

Stainless steel body and topwork,
 "live loaded" gland packing
 "cleaned and degreased for oxygen service"
 with upstream pressure relief hole
 Marking acc. to EN 1626 and EN 12567

Part No. 15080.X.0020

Socket weld connection for stainless steel pipes acc. to ISO 1127

Part No. 15081.X.0020

Butt weld connection for stainless steel pipes acc. to ISO 1127

Available options - on request only:

- End connection for pipes acc. to ASTM A312 S10/S40
- Stainless steel lockable handle
- With pneumatic actuator
- ATEX Ex II 2GD



Applications:

Approved for air gases, vapours and cryogenic liquefied gases.

Working temperature: -200°C / -328°F (73K) up to +200°C / +392°F (473K)

Materials	DIN EN	ASTM
1 Body	1.4409	A 351 CF3M
2 Ball seat	PTFE / Carbon filled (25%)	
3 Ball	1.4409	A 351 CF3M
4 Fitting	1.4404	A 276 Grade 316L
5 Flange	1.4306	A 276 Grade 304L
6 Stem	1.4404	A 276 Grade 316L
7 Elongation tube	1.4306	A 312 TP 304L
8 Gland packing up to DN50	33% C + 2% Gr PTFE	
8a Gland packing from DN65	PTFE	
9 Lever	1.1181	1035

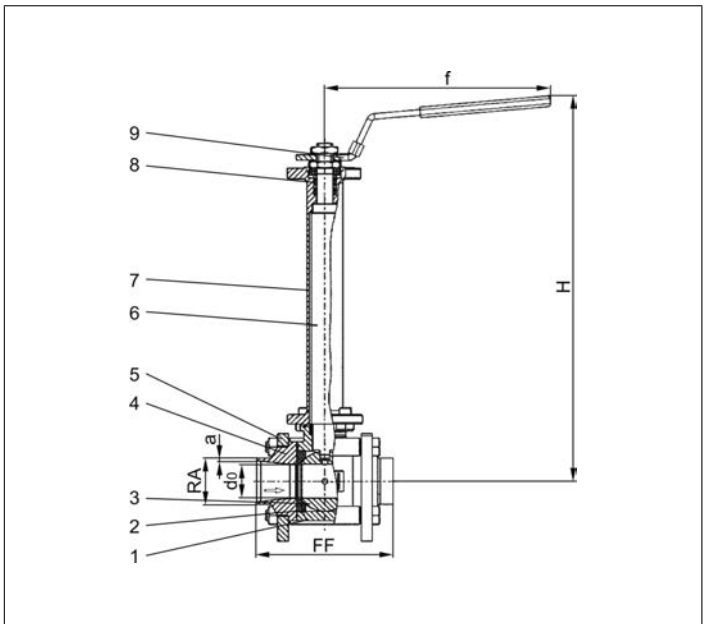

Standard marking acc. to Pressure Equipment Directive 97/23/EC (PED).



Type 15080, 15081	Technical data											
	DN	8	12	15	20	25	32	40	50	65	80	100
Nominal size	.X.	0813	1217	1521	2026	2533	3242	4048	5060	6576	8088	0114
Dimension code	PN	100	100	100	100	70	70	50	50	40	40	25
Nominal pressure	FF	65	65	70	85	100	110	125	150	180	210	230
Face-to-face dimension	H	225	225	230	276	280	321	326	346	426	438	471
Height	RA	13.5	17.2	21.3	26.9	33.7	42.4	48.3	60.3	76.1	88.9	114.3
Outside pipe-Ø ISO 1127	a	2.0	2.0	2.0	2.0	2.0	2.6	2.6	2.9	2.9	2.9	3.2
Wall thickness pipe ISO 1127	d ₀	11.1	11.1	14.0	19.0	25.0	32.0	38.0	50.0	64.0	76.0	100.0
Orifice	f	118	118	118	158	158	188	188	225	370	440	505
Length	ca. kg	1.05	1.05	1.45	2.35	3.05	4.55	6.30	11.10	20.15	32.22	45.00
Weight	m ³ /h	6.0	8.0	13.0	26.0	46.0	82.0	120.0	223.0	423.0	617.0	1154.0
Kvs-Value	gal/min	6.9	9.2	15.0	30.0	53.2	94.8	138.7	257.8	489.0	713.3	1334.0
Cv-Value												

Dimensions in mm.

Ball Valves

Type 15082, Type 15083 - Ball Valve full bore



Cryogenic-3-Piece-Ball Valve

Stainless steel body and topwork,
 "live loaded" gland packing
 "cleaned and degreased for oxygen service"
 with upstream pressure relief hole
 Marking acc. to EN 1626 and EN 12567

Part No. 15082.X.0020

Female thread NPT acc. to ANSI B 1.20.1

Part No. 15083.X.0020

Female thread G (BSPP) acc. to ISO 228/1

Available options - on request only:

- Stainless steel lockable handle
- With pneumatic actuator
- ATEX Ex II 2GD



Applications:

Approved for air gases, vapours and cryogenic liquefied gases.

Working temperature: -200°C / -328°F (73K) up to +200°C / +392°F (473K)

Materials	DIN EN	ASTM
1 Body	1.4409	A 351 CF3M
2 Ball seat	PTFE / Carbon filled (25%)	
3 Ball	1.4409	A 351 CF3M
4 Fitting	1.4404	A 276 Grade 316L
5 Flange	1.4306	A 276 Grade 304L
6 Stem	1.4404	A 276 Grade 316L
7 Elongation tube	1.4306	A 312 TP 304L
8 Gland packing up to DN50	33% C + 2% Gr PTFE	
8a Gland packing from DN65	PTFE	
9 Lever	1.1181	1035

Standard marking acc. to Pressure Equipment Directive 97/23/EC (PED).

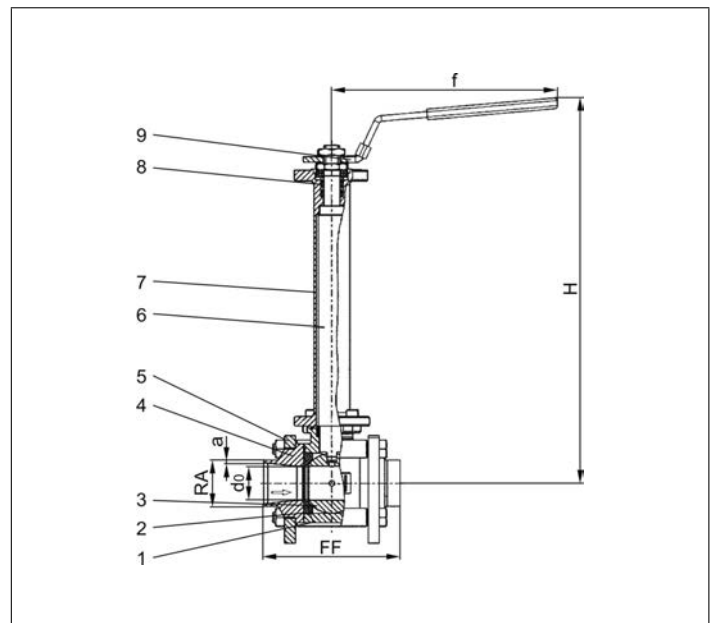

Type 15082, 15083	Technical data											
	DN	8	12	15	20	25	32	40	50	65	80	100
Nominal size	.X.	0200	0300	0400	0600	1000	1200	1400	2000	2400	3000	4000
Dimension code	.X.	0200	0300	0400	0600	1000	1200	1400	2000	2400	3000	4000
BSPP / NPT	threath	1/4"	3/8"	1/2"	3/4"	1"	1-1/4"	1-1/2"	2"	2-1/2"	3"	4"
Nominal pressure	PN	100	100	100	100	70	70	50	50	40	40	25
Face-to-face dimension	FF	65	65	70	85	100	110	125	150	180	210	230
Height	H	225	225	230	276	280	321	326	346	426	438	471
Orifice	d ₀	11.1	11.1	14.0	19.0	25.0	32.0	38.0	50.0	64.0	76.0	100.0
Length	f	118	118	118	158	158	188	188	225	370	440	505
Weight	ca. kg	1.05	1.05	1.45	2.35	3.05	4.55	6.30	11.10	20.15	32.22	45.00
Kvs-Value	m ³ /h	6.0	8.0	13.0	26.0	46.0	82.0	120.0	223.0	423.0	617.0	1154.0
Cv-Value	gal/min	6.9	9.2	15.0	30.0	53.2	94.8	138.7	257.8	489.0	713.3	1334.0

Dimensions in mm.

Ball Valves

Type 15085, Type 15086 - Ball Valve reduced bore



Cryogenic-3-Piece-Ball Valve

Stainless steel body and topwork,
 "live loaded" gland packing
 "cleaned and degreased for oxygen service"
 with upstream pressure relief hole
 Marking acc. to EN 1626

Part No. 15085.X.0000

Socket weld connection for stainless steel pipes acc. to ISO 1127

Part No. 15086.X.0000

Butt weld connection for stainless steel pipes acc. to ISO 1127

Available options - on request only:

- End connection for pipes acc. to ASTM A312 S10/S40
- Female thread connection NPT acc. to ANSI B 1.20.1 (**Part No. 15087**)
- Female thread connection G (BSPP) acc. to ISO 228/1 (**Part No. 15088**)
- Stainless steel lockable handle
- With pneumatic actuator
- ATEX Ex II 2GD



Applications:

Approved for air gases, vapours and cryogenic liquefied gases.

Working temperature: -50°C / -58°F (223K) up to +190°C / +374°F (463K)

Materials	DIN EN	ASTM
1 Body	1.4409	CF3M (316L)
2 Ball seat	PTFE / Carbon filled (25%)	
3 Ball	1.4409	CF3M (316L)
4 Fitting	1.4404	316L
5 Flange	1.4306	304L
6 Stem	1.4404	316L
8 Gland packing up to DN50	33% C + 2% Gr PTFE	
8a Gland packing from DN65	PTFE	
9 Lever	1.1181	1035

Standard marking acc. to Pressure Equipment Directive 97/23/EC (PED).

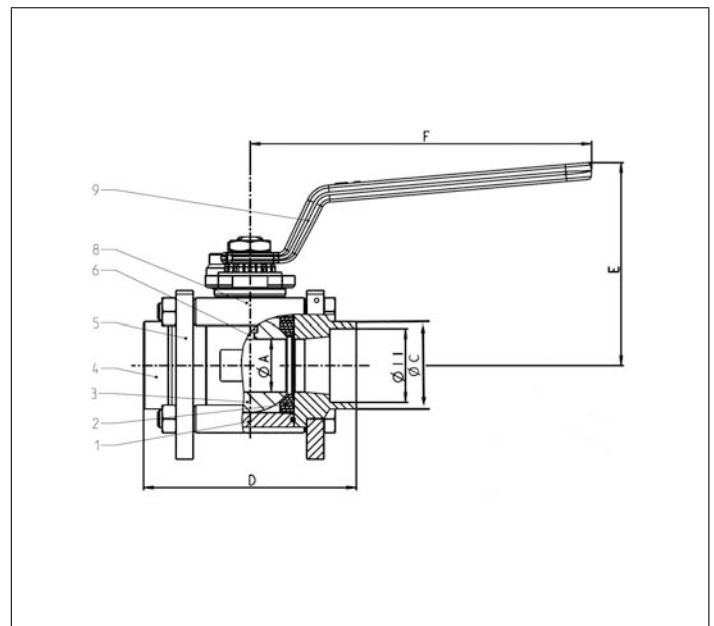

Type 15085, 15086	Technical data											
	DN	15	20	25	32	40	50	65	80	100	125	150
Nominal size	.X.	1521	2026	2533	3242	4048	5060	6576	8088	0114	0141	0168
Dimension code	PN	100	100	100	70	70	50	50	40	40	25	25
Nominal pressure	D	65	70	85	100	110	125	150	180	210	230	260
Face-to-face dimension	E	70	73	91	95	111	116	137	171	182	204	248
Height	Ø C	21.3	26.9	33.7	42.4	48.3	60.3	76.1	88.9	114.3	139.7	168.3
Outside pipe-Ø ISO 1127	a	2.0	2.0	2.0	2.6	2.6	2.9	2.9	2.9	3.2	3.0	3.0
Wall thickness pipe ISO 1127	Ø I1	21.9	27.3	34.0	42.8	48.9	61.3	77.6	89.9	115.5	141.3	171.3
Pipe diameter SW	Ø A	11.1	14.0	19.0	25.0	32.0	38.0	50.0	64.0	76.0	100.0	125.0
Orifice	F	120	160	160	190	190	230	370	440	505	710	710
Length	ca. kg	0.65	0.80	1.61	2.10	3.12	4.30	8.59	14.84	22.31	33.98	57.94
Weight	m³/h	8.0	13.0	26.0	46.0	82.0	120.0	223.0	397.0	560.0	942.0	1433.0
Kvs-Value	gal/min	9.2	15.0	30.0	53.2	94.8	138.7	257.8	489.0	713.3	1083.3	1648.0
Cv-Value												

Dimensions in mm.

Ball Valves

Type 15085, Type 15086 - Ball Valve reduced bore



Cryogenic-3-Piece-Ball Valve

Stainless steel body and topwork,
 "live loaded" gland packing
 "cleaned and degreased for oxygen service"
 with upstream pressure relief hole
 Marking acc. to EN 1626 and EN 12567

Part No. 15085.X.0020

Socket weld connection for stainless steel pipes acc. to ISO 1127

Part No. 15086.X.0020

Butt weld connection for stainless steel pipes acc. to ISO 1127

Available options - on request only:

- End connection for pipes acc. to ASTM A312 S10/S40
- Female thread connection NPT acc. to ANSI B 1.20.1 (**Part No. 15087**)
- Female thread connection G (BSPP) acc. to ISO 228/1 (**Part No. 15088**)
- Stainless steel lockable handle
- With pneumatic actuator
- ATEX Ex II 2GD



Applications:

Approved for air gases, vapours and cryogenic liquefied gases.

Working temperature: -200°C / -328°F (73K) up to +200°C / +392°F (473K)

Materials	DIN EN	ASTM
1 Body	1.4409	A 351 CF3M
2 Ball seat	PTFE / Carbon filled (25%)	
3 Ball	1.4409	A 351 CF3M
4 Fitting	1.4404	A 276 Grade 316L
5 Flange	1.4306	A 276 Grade 304L
6 Stem	1.4404	A 276 Grade 316L
7 Elongation tube	1.4306	A 312 TP 304L
8 Gland packing up to DN50	33% C + 2% Gr PTFE	
8a Gland packing from DN65	PTFE	
9 Lever	1.1181	1035

Standard marking acc. to Pressure Equipment Directive 97/23/EC (PED).

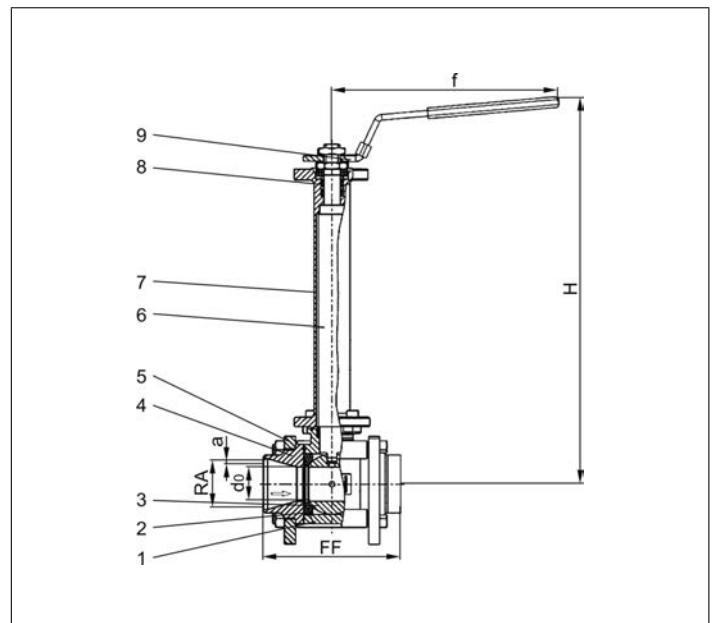

Type 15085, 15086	Technical data										
	DN	15	20	25	32	40	50	65	80	100	125
Nominal size											
Dimension code	.X.	1521	2026	2533	3242	4048	5060	6576	8088	0114	0141
Nominal pressure	PN	100	100	100	70	70	50	50	40	40	25
Face-to-face dimension	FF	65	70	85	100	110	125	150	180	210	230
Height	H	230	276	280	321	326	346	426	438	471	471
Outside pipe-Ø ISO 1127	RA	21.3	26.9	33.7	42.4	48.3	60.3	76.1	88.9	114.3	139.7
Wall thickness pipe ISO 1127	a	2.0	2.0	2.0	2.6	2.6	2.9	2.9	2.9	3.2	3.0
Orifice	d ₀	11.1	14.0	19.0	25.0	32.0	38.0	50.0	64.0	76.0	100.0
Length	f	118	158	158	188	188	225	370	440	505	710
Weight	ca. kg	1.45	2.35	3.05	4.55	6.30	11.10	20.15	32.22	45.00	48.50
Kvs-Value	m ³ /h	8.0	13.0	26.0	46.0	82.0	120.0	223.0	397.0	560.0	942.0
Cv-Value	gal/min	9.2	15.0	30.0	53.2	94.8	138.7	257.8	456.6	644.0	1083.3

Dimensions in mm.

Actuated Valves

Type 01313 - Actuated Globe Valve



Cryogenic-Globe Valves with Pneumatic Actuator, PN50

Bronze body and stainless steel topwork (internal parts bronze)

Actuator - air opens, spring closes or contrary

"live loaded" gland packing

"cleaned and degreased for oxygen service" - the actuator is not cleaned and degreased for oxygen

Part No. 01313.X.*010

Socket end for copper pipes acc. to DIN EN 12449 or ASTM B88

Available accessories:

- Solenoid valve
- Limit switch
- Electropneumatic positioner etc.

Available options - on request only:

- Socket end for stainless steel pipes acc. to ISO 1127
- Actuator "cleaned and degreased for oxygen service"
- Electric actuator
- Valve with check disc



Applications:

Approved for air gases, vapours and cryogenic liquefied gases incl. LNG.

Working temperature: -196°C / -321°F (77K) up to +120°C / +248°F (393K)

Materials	DIN EN	ASTM
1 Body	CC491K	B 62 UNS C83600
2 Valve seal	PTFE / Carbon filled (25%)	
3 Disc	CW614N	B 283 UNS C38500
4 Bonnet gasket	PTFE	
5 Headpiece	1.4301	A 276 Grade 304
6 Bolts	1.4301/A2	A 194 B8
7 Elongation tube	1.4541	A 213 TP 321
8 Stem	1.4301	A 276 Grade 304
9 Gland packing	Graphite / PTFE	
10 Gland nut	CW614N	B 283 UNS C38500
11 Pillars	1.4404	A 276 Grade 316L
12 Bush	CW452K	B 159 UNS C51900

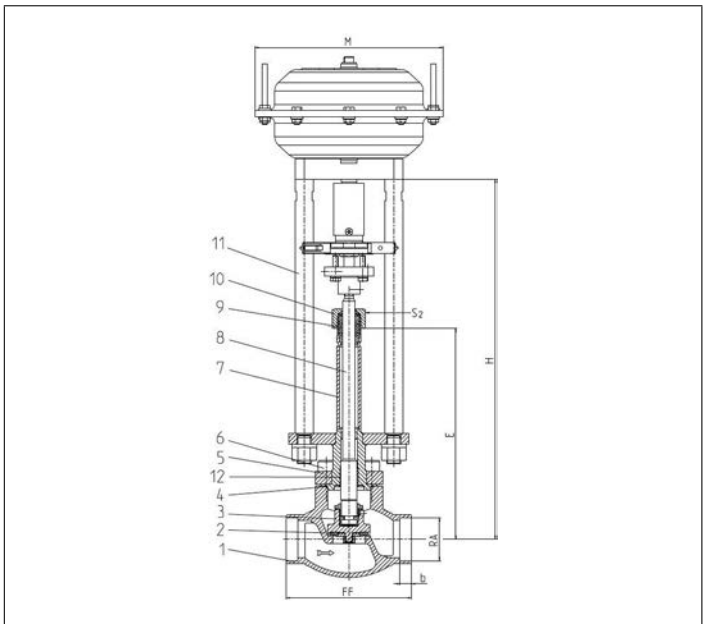

Standard marking acc. to Pressure Equipment Directive 97/23/EC (PED).



Type 01313 - Standard design	Technical data							
	DN	10	15	20	25	32	40	50
Nominal size	DN	10	15	20	25	32	40	50
Dimension code	.X.	X=DNRA, Example: valve DN 15 for copper pipe RA Ø 18mm, X=1518						
Face-to-face dimension	FF	60	85	85	115	115	140	160
Height	H	370	370	370	375	405	420	425
Length	E	195	195	200	200	230	230	235
Outside pipe-Ø	RA	dependent on order						
Socket depth	b	6	6	8	8	10	13	20
Actuator-Ø	M	dependent on actuator						
Wrench size across flats	S ₂	30	30	30	30	36	36	36
Weight w/o actuator	ca. kg	1.6	2.3	2.7	3.1	4.3	6.2	9.2
Kvs-Value	m ³ /h	1.6	4.3	6.7	11.5	12.1	22.6	37.1
Cv-Value	gal/min	1.9	5.0	7.8	13.4	14.1	26.3	43.2
Stroke	mm	10	10	7	9	9	11	15

Dimensions in mm.

Actuated Valves

Type 01313 - Actuated Globe Valve



Cryogenic-Globe Valves with Pneumatic Actuator, PN50

Bronze body and stainless steel topwork (internal parts bronze)

Actuator - air opens, spring closes or contrary

"live loaded" gland packing

"cleaned and degreased for oxygen service" - the actuator is not cleaned and degreased for oxygen

Part No. 01313.X.*017

Complete with stainless steel stubs acc. to DIN EN 10216-5 or ASTM A312

Available accessories:

- Solenoid valve
- Limit switch
- Electropneumatic positioner etc.

Available options - on request only:

- Actuator "cleaned and degreased for oxygen service"
- Electric actuator
- Valve with check disc
- Valve with control disc (tapered design)



Applications:

Approved for air gases, vapours and cryogenic liquefied gases incl. LNG.

Working temperature: -196°C / -321°F (77K) up to +120°C / +248°F (393K)

Materials	DIN EN	ASTM
1 Body	CC491K	B 62 UNS C83600
2 Valve seal	PTFE / Carbon filled (25%)	
3 Disc	CW614N	B 283 UNS C38500
4 Bonnet gasket	PTFE	
5 Headpiece	1.4301	A 276 Grade 304
6 Bolts	1.4301/A2	A 194 B8
7 Elongation tube	1.4541	A 213 TP 321
8 Stem	1.4301	A 276 Grade 304
9 Gland packing	Graphite / PTFE	
10 Gland nut	CW614N	B 283 UNS C38500
11 Pillars	1.4404	A 276 Grade 316L
12 Bush	CW452K	B 159 UNS C51900
13 Stainless steel stubs	1.4306	A 312 TP304L

Standard marking acc. to Pressure Equipment Directive 97/23/EC (PED).

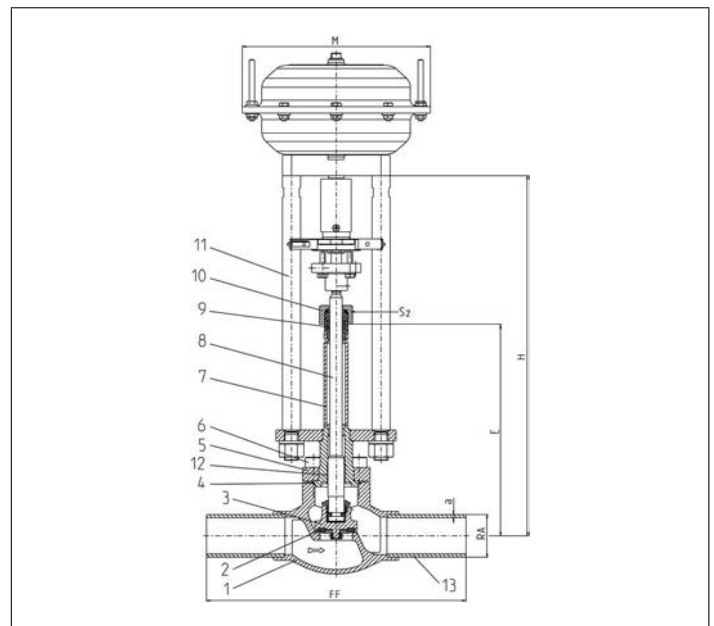

Type 01313 - Standard design	Technical data									
	DN	10	10	15	20	25	32	40	50	
Nominal size	DN	10	10	15	20	25	32	40	50	
Dimension code	.X.	1012	1017	1521	2027	2533	3242	4048	5060	
Face-to-face dimension	FF	210	210	235	235	265	265	290	310	
Height	H	370	370	370	370	375	405	420	425	
Length	E	195	195	195	200	200	230	230	235	
Outside pipe-Ø ISO 1127	RA	12.0	17.2	21.3	26.9	33.7	42.4	48.3	60.3	
Wall thickness pipe ISO 1127	a	1.0	2.3	2.6	2.9	3.2	3.2	3.6	3.6	
Outside pipe-Ø ASTM A312	RA	-	17.15	21.34	26.67	33.4	42.16	48.26	60.33	
Wall thickness pipe ASTM A312	a	dimensions acc. to S10 or S40								
Actuator-Ø	M	dependent on actuator								
Wrench size across flats	S ₂	30	30	30	30	30	36	36	36	
Weight w/o actuator	ca. kg	1.75	1.85	2.6	3.0	3.5	4.7	6.7	9.8	
Kvs-Value	m ³ /h	1.6	2.2	4.3	6.7	11.5	12.1	22.6	37.1	
Cv-Value	gal/min	1.9	2.6	5.0	7.8	13.4	14.1	26.3	43.2	
Stroke	mm	10	10	10	7	9	9	11	15	

Dimensions in mm.

Actuated Valves

Type 01314 - Actuated Globe Valve



Cryogenic-Globe Valves with Pneumatic Actuator, PN50

Bronze body and stainless steel topwork (internal parts bronze)

Actuator - air opens, spring closes or contrary

"live loaded" gland packing

"cleaned and degreased for oxygen service" - the actuator is not cleaned and degreased for oxygen

Part No. 01314.X.*011

Female thread connection (G) acc. to ISO 228/1

Part No. 01314.X.*016

Female thread connection NPT acc. to ANSI B 1.20.1

Available accessories:

- Solenoid valve
- Limit switch
- Electropneumatic positioner etc.

Available options - on request only:

- Actuator "cleaned and degreased for oxygen service"
- Electric actuator · Valve with check disc

Applications:

Approved for air gases, vapours and cryogenic liquefied gases incl. LNG.

Working temperature: -196°C / -321°F (77K) up to +120°C / +248°F (393K)



Materials	DIN EN	ASTM
1 Body	CC491K	B 62 UNS C83600
2 Valve seal	PTFE / Carbon filled (25%)	
3 Disc	CW614N	B 283 UNS C38500
4 Bonnet gasket	PTFE	
5 Headpiece	1.4301	A 276 Grade 304
6 Bolts	1.4301/A2	A 194 B8
7 Elongation tube	1.4541	A 213 TP 321
8 Stem	1.4301	A 276 Grade 304
9 Gland packing	Graphite / PTFE	
10 Gland nut	CW614N	B 283 UNS C38500
11 Pillars	1.4404	A 276 Grade 316L
12 Bush	CW452K	B 159 UNS C51900

Standard marking acc. to Pressure Equipment Directive 97/23/EC (PED).

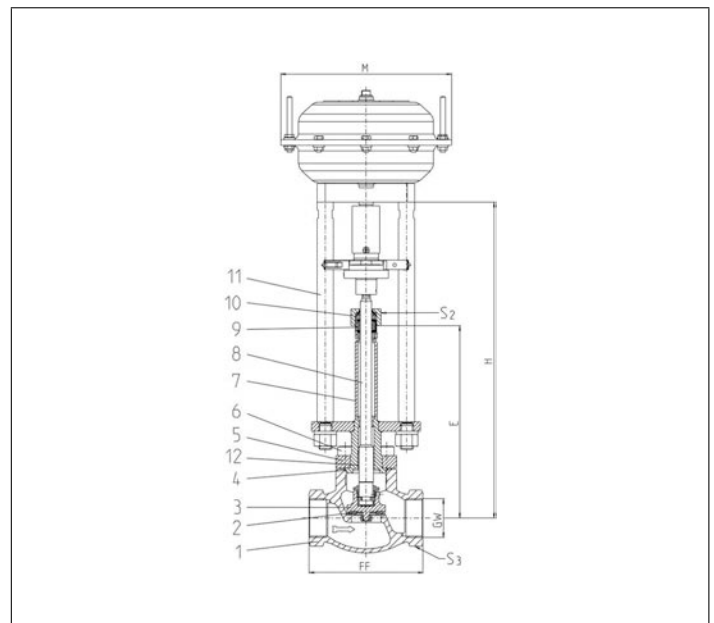

Type 01314 - Standard design	Technical data									
Nominal size	DN	10	10	15	20	25	32	40	50	
Thread size	GW	1/4	3/8	1/2	3/4	1	1-1/4	1-1/2	2	
Dimension code	.X.	0200	0300	0400	0600	1000	1200	1400	2000	
Face-to-face dimension	FF	60	60	85	85	115	115	140	160	
Height	H	370	370	370	370	375	405	420	425	
Length	E	195	195	195	200	200	230	230	235	
Actuator-Ø	M	dependent on actuator								
Wrench size across flats	S ₂	30	30	30	30	30	36	36	36	
Wrench size across flats	S ₃	rund	rund	30	36	41	rund	60	75	
Weight w/o actuator	ca. kg	1.6	1.6	2.3	2.7	3.1	4.3	6.2	9.2	
Kvs-Value	m ³ /h	1.6	2.2	4.3	6.7	11.5	12.1	22.6	37.1	
Cv-Value	gal/min	1.9	2.6	5.0	7.8	13.4	14.1	26.3	43.2	

Dimensions in mm.

Actuated Valves

Type 02413 - Actuated Globe Valve



Cryogenic-Globe Valves with Pneumatic Actuator, PN50

Bronze body and stainless steel topwork, inner parts in brass

Actuator - air opens, spring closes or contrary

"live loaded" gland packing

"cleaned and degreased for oxygen service" - the actuator is not cleaned and degreased for oxygen

Part No. 02413.X.*011

Male thread for union connection

Available accessories:

- Solenoid valve
- Limit switch
- Electropneumatic positioner etc.

Available options - on request only:

- Socket end for stainless steel pipes acc. to ISO 1127
- Actuator "cleaned and degreased for oxygen service"
- Electric actuator
- Valve with check disc

Applications:

Approved for air gases, vapours and cryogenic liquefied gases incl. LNG.

Working temperature: -196°C / -321°F (77K) up to +120°C / +248°F (393K)



Materials	DIN EN	ASTM
1 Body	CC491K	B 62 UNS C83600
2 Valve seal	PTFE / Carbon filled (25%)	
3 Disc	CW614N	B 283 UNS C38500
4 Bonnet gasket	PTFE	
5 Headpiece	1.4301	A 276 Grade 304
6 Bolts	1.4301/A2	A 194 B8
7 Elongation tube	1.4541	A 213 TP 321
8 Stem	1.4301	A 276 Grade 304
9 Gland packing	Graphite / PTFE	
10 Gland nut	CW614N	B 283 UNS C38500
11 Pillars	1.4404	A 276 Grade 316L
12 Bush	CW452K	B 159 UNS C51900

Standard marking acc. to Pressure Equipment Directive 97/23/EC (PED).

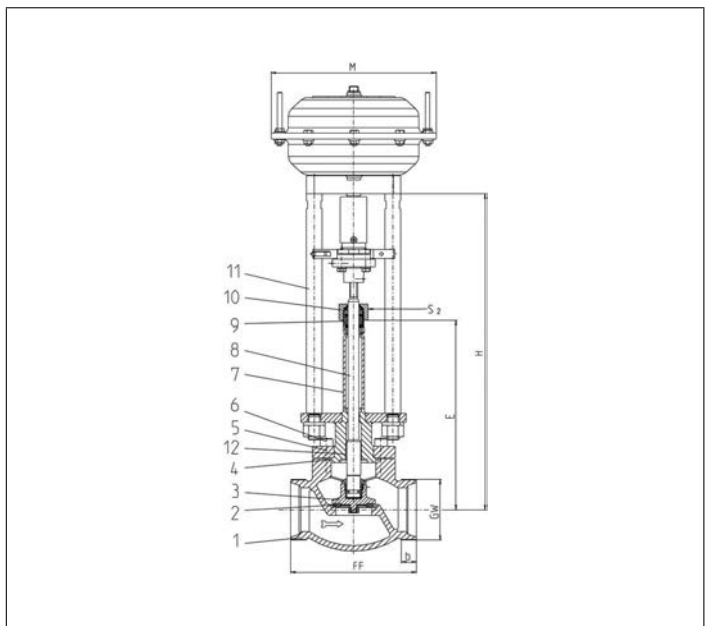

Type 02413 - Standard design	Technical data					
Nominal size	DN	10	20	32	40	50
Dimension code	.X.	0100	0200	0320	0400	0500
Face-to-face dimension	FF	60	85	115	140	160
Union thread	GW	M26x1.5	M40x2.0	M55x2.0	M65x2.0	M78x2.0
Height	H	370	370	405	420	425
Length	E	195	200	230	230	235
Thread length	b	10	11	14	17	20
Actuator-Ø	M	dependent on actuator				
Wrench size across flats	S ₂	30	30	36	36	36
Weight w/o actuator	ca. kg	1.6	2.7	4.3	6.2	9.2
Kvs-Value	m ³ /h	2.2	6.7	12.1	22.6	37.1
Cv-Value	gal/min	2.6	7.8	14.1	26.3	43.2

Dimensions in mm.

Actuated Valves

Type 01343 - Actuated Globe Valve



Cryogenic-Globe Valves with Pneumatic Actuator, PN50 (DN100/150=PN40)

Stainless steel body and topwork

Actuator - air opens, spring closes or contrary

"live loaded" gland packing

"cleaned and degreased for oxygen service" - the actuator is not cleaned and degreased for oxygen

Part No. 01343.X.*01*

Butt weld connection for stainless steel pipes acc. to ISO 1127 or ASTM A312

Part No. 01343.X.*014

Socket weld connection for stainless steel pipes acc. to ISO 1127 or ASTM A312

Available accessories:

- Solenoid valve · Limit switch
- Electropneumatic positioner etc.

Available options - on request only:

- Welded stainless steel stubs acc. to ISO 1127 or ASTM A312 - length FF + 200mm
- Actuator "cleaned and degreased for oxygen service"
- Electric actuator · Valve with check disc, valve with control disc (tapered design)



Applications:

Approved for air gases, vapours and cryogenic liquefied gases incl. LNG.

Working temperature: -196°C / -321°F (77K) up to +120°C / +248°F (393K)

Materials	DIN EN	ASTM
1 Body	1.4308	A 351 CF8
2 Valve seal up to DN50	PTFE / Carbon filled (25%)	
2a Valve seal from DN65	PTFE	
3 Disc	1.4301	A 276 Grade 304
4 Bonnet gasket	PTFE	
5 Headpiece	1.4301	A 276 Grade 304
6 Bolts	1.4301/A2	A 194 B8
7 Elongation tube	1.4541	A 213 TP 321
8 Stem	1.4301	A 276 Grade 304
9 Gland packing	Graphite / PTFE / MICA	
10 Gland nut	1.4305	A 276 Grade 303
11 Pillars	1.4404	A 276 Grade 316L
12 Bush	CW452K	B 159 UNS C51900
13 Spring	CW452K	B 159 UNS C51900

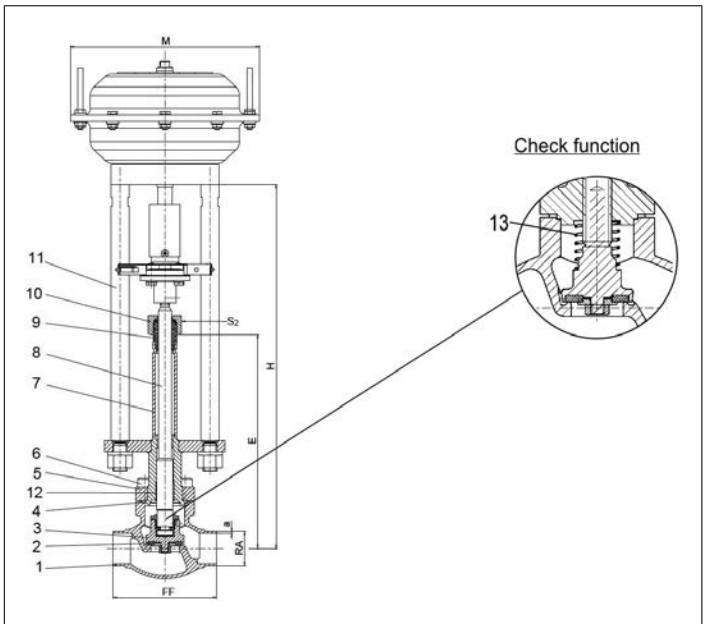

Standard marking acc. to Pressure Equipment Directive 97/23/EC (PED).



Type 01343 - Standard	Technical data														
	DN	10	15	15	20	25	32	40	40	50	65	80	100	150	
Nominal size	DN	10	15	15	20	25	32	40	40	50	65	80	100	150	
Dimension code	.X.	1012	1517	1521	2026	2533	3238	4042	4048	5060	657x	8088	0114	0168	
Face-to-face dimension	FF	70	85	85	100	115	115	130	130	155	205	245	280	400	
Height	H	370	370	370	370	375	405	420	420	425	510	575	635	685	
Length	E	195	195	195	200	200	230	230	230	235	300	300	300	300	
Outside pipe-Ø ISO 1127	RA	12.0	17.2	21.3	26.9	33.7	38.0	42.4	48.3	60.3	76.1	88.9	114.3	168.3	
Wall thickness pipe ISO 1127	a	1.0	1.6	2.0	2.0	2.0	2.0	2.0	2.0	2.0	2.6	3.2	6.0	7.1	
Outside pipe-Ø ASTM A312	RA	13.72	17.15	21.34	26.67	33.40	-	42.16	48.26	60.33	73.03	88.90	114.3	168.3	
Wall thickness pipe ASTM A312	a	dimensions acc. to S10 or S40													
Socket depth	b	6	10	10	13	13	-	13	13	16	16	16	20	20	
Actuator-Ø	M	dependent on actuator													
Wrench size across flats	S ₂	30	30	30	30	30	36	36	36	36	36	36	41	41	
Weight w/o actuator	ca. kg	1.9	2.15	2.2	2.4	3.1	3.8	6.5	6.5	9.0	15.2	20.0	28.0	60.9	
Kvs-Value	m ³ /h	1.6	3.8	4.3	6.7	11.5	14.0	20.6	22.6	37.1	71.1	104.0	170.0	350.0	
Cv-Value	gal/min	1.9	4.4	5.0	7.8	13.4	16.2	23.9	26.3	43.2	82.7	120.9	195.2	401.8	
Stroke	mm	10	10	10	7	9	9	11	11	15	23	23	30	40	

Dimensions in mm. Compliance of tightness requirements acc. to EN 1626 for DN150 up to 20 bar differential pressure. In the range of >20-40 bar, 350-700ml (1 bar, 20°C [68°F]) are reached.

Actuated Valves

Type 01343 - Actuated Globe Valve



Cryogenic-Globe Valves with Pneumatic Actuator, PN50 (DN100/150=PN40)

Stainless steel body and topwork

Actuator - air opens, spring closes or contrary

"live loaded" gland packing

"cleaned and degreased for oxygen service" - the standard actuator is not cleaned and degreased for oxygen

Part No. 01343.X.0010

possible connections:

- Butt weld connection for stainless steel pipes acc. to ISO 1127 or ASTM A312
- Socket weld connection for stainless steel pipes acc. to ISO 1127 or ASTM A312
- Female thread connection (G) acc. to ISO 228/1 or NPT acc. to ANSI B 1.20.1

Please specify the required connection when ordering!

Available options - on request only:

- Solenoid valves · Electropneumatic positioner
- Inductive Proximity Switches · Position and Limit Switches · Air control sets
- Welded stainless steel stubs acc. to ISO 1127 or ASTM A312 - length FF + 200mm
- Actuator "cleaned and degreased for oxygen service" · Electric actuator
- Valve with check disc · valve with control disc (tapered design)

Applications:

Approved for air gases, vapours and cryogenic liquefied gases incl. LNG.

Working temperature: -196°C / -321°F (77K) up to +120°C / +248°F (393K)



Materials	DIN EN	ASTM
1 Body	1.4308	A 351 CF8
2 Valve seal up to DN50	PTFE / Carbon filled (25%)	
2a Valve seal from DN65	PTFE	
3 Disc	1.4301	A 276 Grade 304
4 Bonnet Gasket	PTFE	
5 Headpiece	1.4301	A 276 Grade 304
6 Bolts	1.4301/A2	A 194 B8
7 Elongation tube	1.4541	A 213 TP 321
8 Stem	1.4301	A 276 Grade 304
9 Gland packing	Graphite / PTFE / MICA	
10 Gland nut	1.4305	A 276 Grade 303
11 Pillars	1.4404	A 276 Grade 316L
12 Bush	CW452K	B 159 UNS C51900
13 Spring	CW452K	B 159 UNS C51900

Standard marking acc. to Pressure Equipment Directive 97/23/EC (PED).

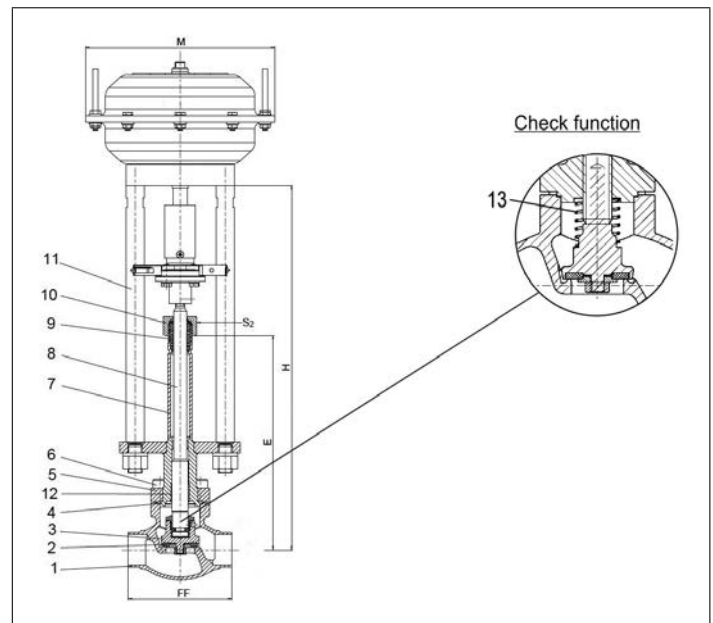

Type 01343 - Standard	Technical Data											
Nominal size	DN	10	15	20	25	32	40	50	65	80	100	150
Dimension code	.X.	0100	0150	0200	0250	0320	0400	0500	0650	0800	1000	1500
Face-to-face dimension	FF	70	85	100	115	115	130	155	205	245	280	400
Height	H	370	370	370	375	405	420	425	510	575	635	685
Length	E	195	195	200	200	230	230	235	300	300	300	300
Actuator-Ø	M	dependent on actuator										
Wrench size across flats	S ₂	30	30	30	30	36	36	36	36	36	41	41
Weight w/o actuator	ca. kg	1.9	2.15	2.4	3.1	3.8	6.5	9.0	15.2	20.0	28.0	60.9
Kvs - Value	m ³ /h	1.6	3.8	6.7	11.5	14.0	20.6	37.1	71.1	104.0	170.0	350.0
Cv - Value	gal/min	1.9	4.4	7.8	13.4	16.2	23.9	43.2	82.7	120.9	195.2	401.8
Stroke	mm	10	10	7	9	9	11	15	23	23	30	40

Dimensions in mm. Compliance of tightness requirements acc. to EN 1626 for DN150 up to 20 bar differential pressure. In the range of >20-40 bar, 350-700ml (1 bar, 20°C [68°F]) are reached.

Actuated Valves

Type 01343 - Actuated Globe Valve

HEROSE



Connection types

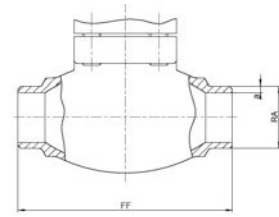

Butt weld connection acc. to · ISO 1127

DN	Face-to-face dim. (FF) [mm]	Outside pipe-Ø ISO (RA) [mm]	Wall thickness pipe ISO (a) [mm]	Kvs-value [m ³ /h]	Cv-value [gal/min]	Weight w.a.* [kg]	Order reference
10	70	13.5	1.0	1.6	1.9	1.9	BW 13.5x1.0
15	85	17.2	1.6	3.8	4.4	2.2	BW 17.2x1.6
15	85	21.3	2.0	4.3	5.0	2.2	BW 21.3x2.0
20	100	26.9	2.0	6.7	7.8	2.4	BW 26.9x2.0
25	115	33.7	2.0	11.5	13.4	3.1	BW 33.7x2.0
32	115	38.0	2.0	14.0	16.2	3.8	BW 38.0x2.0
40	130	42.4	2.0	20.6	23.9	6.5	BW 42.4x2.0
40	130	48.3	2.0	22.6	26.3	6.5	BW 48.3x2.0
50	155	60.3	2.0	37.1	43.2	9.0	BW 60.3x2.0
65	205	76.1	2.6	71.1	82.7	15.2	BW 76.1x2.6
80	245	88.9	3.2	104.0	120.9	20.0	BW 88.9x3.2
100	280	114.3	6.0	170.0	195.2	28.0	BW 114.3x6.0
150	400	168.3	7.1	350.0	401.8	60.9	BW 168.3x7.1

Butt weld connection acc. to · ASTM A312

DN	Face-to-face dim. (FF) [mm]	Outside pipe-Ø ASTM (RA) [inch / mm]	Wall thickness pipe ASTM (a) [mm]	Kvs-value [m ³ /h]	Cv-value [gal/min]	Weight w.a.* [kg]	Order reference
10	70	1/4" / 13.72	1.65	1.6	1.9	1.9	BW 13.72x1.65
15	85	1/2" / 17.15	1.65	3.8	4.4	2.2	BW 17.15x1.65
15	85	1/2" / 21.34	2.11	4.3	5.0	2.2	BW 21.34x2.11
20	100	3/4" / 26.67	2.11	6.7	7.8	2.4	BW 26.67x2.11
25	115	1" / 33.40	2.77	11.5	13.4	3.1	BW 33.40x2.77
40	130	1-1/2" / 42.16	2.77	20.6	23.9	6.5	BW 42.16x2.77
40	130	1-1/2" / 48.26	2.77	22.6	26.3	6.5	BW 48.26x2.77
50	155	2" / 60.32	2.77	37.1	43.2	9.0	BW 60.32x2.77
65	205	2-1/2" / 73.02	3.05	71.1	82.7	15.2	BW 73.02x3.05
80	245	3" / 88.90	3.05	104.0	120.9	20.0	BW 88.90x3.05
100	280	4" / 114.30	3.05	170.0	195.2	28.0	BW 114.30x3.05
150	400	6" / 168.27	3.40	350.0	401.8	60.9	BW 168.27x3.40
10	70	1/4" / 13.72	2.24	1.6	1.9	1.9	BW 13.72x2.24
15	85	1/2" / 17.15	2.31	3.8	4.4	2.2	BW 17.15x2.31
15	85	1/2" / 21.34	2.77	4.3	5.0	2.2	BW 21.34x2.77
20	100	3/4" / 26.67	2.87	6.7	7.8	2.4	BW 26.67x2.87
25	115	1" / 33.40	3.38	11.5	13.4	3.1	BW 33.40x3.38
40	130	1-1/2" / 42.16	3.56	20.6	23.9	6.5	BW 42.16x3.56
40	130	1-1/2" / 48.26	3.68	22.6	26.3	6.5	BW 48.26x3.68
50	155	2" / 60.32	3.91	37.1	43.2	9.0	BW 60.32x3.91
65	205	2-1/2" / 73.02	5.16	71.1	82.7	15.2	BW 73.02x5.16
80	245	3" / 88.90	5.49	104.0	120.9	20.0	BW 88.90x5.49
100	280	4" / 114.30	6.02	170.0	195.2	28.0	BW 114.30x6.02
150	400	6" / 168.27	7.11	350.0	401.8	60.9	BW 168.27x7.11

w.a.* = without actuator

Actuated Valves

Type 01343 - Actuated Globe Valve



Connection types

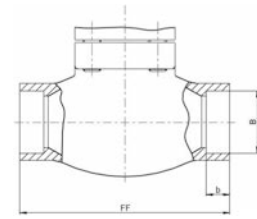

Socket weld connection acc. to

- ISO 1127
- ASTM A312

DN	Face-to-face dim. (FF) [mm]	Socket depth (b) [mm]	Socket diameter (B) [mm]	Kvs-value [m ³ /h]	Cv-value [gal/min]	Weight, w.a.* [kg]	order reference [ØISO / ØASTM]
10	70	6	14.1	1.6	1.9	1.9	SW 13.5 / 13.72
15	85	10	17.5	3.8	4.4	2.2	SW 17.2 / 17.15
15	85	10	21.5	4.3	5.0	2.2	SW 21.3 / 21.34
20	100	13	27.5	6.7	7.8	2.4	SW 26.9 / 26.67
25	115	13	34.1	11.5	13.4	3.1	SW 33.7 / 33.4
40	130	13	42.8	20.6	23.9	6.5	SW 42.4 / 42.16
40	130	13	48.6	22.6	26.3	6.5	SW 48.3 / 48.26
50	155	16	61.1	37.1	43.2	9.0	SW 60.3 / 60.32
65	205	16	74.0	71.1	82.7	15.1	SW 73.02
65	205	16	76.8	71.1	82.7	15.2	SW 76.1
80	245	16	90.0	104.0	120.9	20.0	SW 88.9
100	280	20	114.8	170.0	195.2	28.0	SW 114.3
150	400	20	168.2	350.0	401.8	60.9	SW 168.3 / 168.27

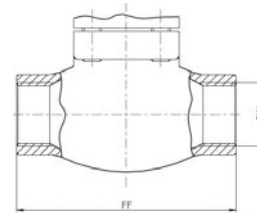

Female thread connection acc. to

- ISO 228/1 (G)
- NPT acc. to ANSI B 1.20.1 (NPT)

DN	Face-to-face dim. (FF) [mm]	Thread size (GW)	Kvs-value [m ³ /h]	Cv-value [gal/min]	Weight, w.a.* [kg]	order reference G-Thread	order reference NPT-Thread
10	70	1/4"	1.6	1.9	1.9	1/4 BSPP	1/4" NPT
10	70	3/8"	2.2	2.6	1.9	3/8 BSPP	3/8" NPT
15	85	1/2"	4.3	5.0	2.2	1/2 BSPP	1/2" NPT
20	100	3/4"	6.7	7.8	2.4	3/4 BSPP	3/4" NPT
25	115	1"	11.5	13.4	3.1	1 BSPP	1" NPT
40	130	1-1/4"	20.6	23.9	6.5	1-1/4 BSPP	1-1/4" NPT
40	130	1-1/2"	22.6	26.3	6.5	1-1/2 BSPP	1-1/2" NPT
50	155	2"	37.1	43.2	9.0	2 BSPP	2" NPT

w.a.* = without actuator

Actuated Valves

Type 03323 - Actuated Globe Valve



Cryogenic-Globe Valves with Pneumatic Actuator, PN16

Stainless steel body and topwork

Actuator - air opens, spring closes or contrary

"live loaded" gland packing

"cleaned and degreased for oxygen service" - the actuator is not cleaned and degreased for oxygen

Part No. 03323.X.*014

Flanged connection acc. to DIN EN 1092-1 PN16

Available accessories:

- Solenoid valve
- Limit switch
- Electropneumatic positioner etc.

Available options - on request only:

- Actuator - "cleaned and degreased for oxygen service"
- Electric actuator
- Valve with check disc
- Valve with control disc (tapered design)
- Nominal sizes DN15, DN20 and DN150 with welded flange

Applications:

Approved for air gases, vapours and cryogenic liquefied gases incl. LNG.

Working temperature: -196°C / -321°F (77K) up to +120°C / +248°F (393K)



Materials	DIN EN	ASTM
1 Body	1.4308	A 351 CF8
2 Valve seal up to DN50	PTFE / Carbon filled (25%)	
2a Valve seal from DN65	PTFE	
3 Disc	CW614N	B 283 UNS C38500
4 Bonnet gasket	PTFE	
5 Headpiece	1.4301	A 276 Grade 304
6 Bolts	1.4301/A2	A 194 B8
7 Elongation tube	1.4541	A 213 TP 321
8 Stem	1.4301	A 276 Grade 304
9 Gland packing	Graphite / PTFE	
10 Gland nut	CW614N	B 283 UNS C38500
11 Pillars	1.4404	A 276 Grade 316L
12 Bush	CW452K	B 159 UNS C51900

Standard marking acc. to Pressure Equipment Directive 97/23/EC (PED).

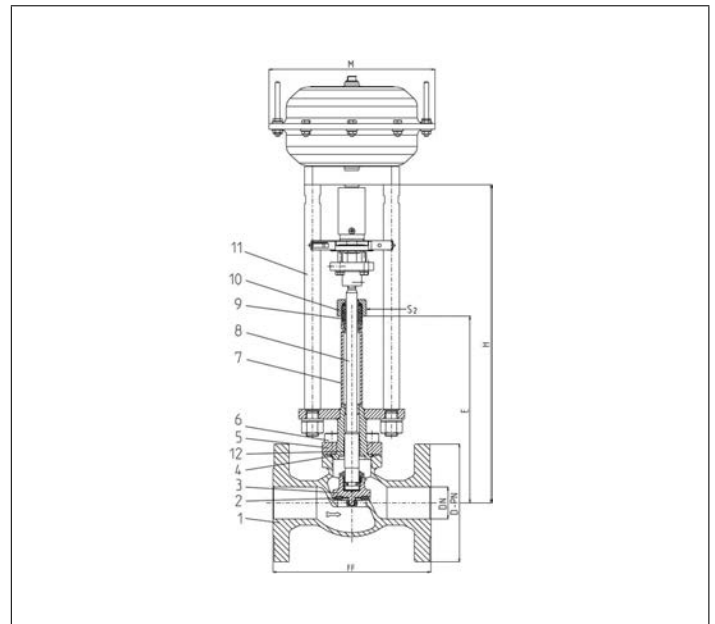

Type 03323 - Standard design	Technical data								
	DN	25	40	50	65	80	100	125	150
Nominal size	DN	25	40	50	65	80	100	125	150
Dimension code - Flange EN 1092-1 PN16	.X.	0250	0400	0500	0650	0800	1000	1250	1500
Flange-Ø	D-PN	115	150	165	185	200	235	250	285
Face-to-face dimension	FF	160	200	230	290	310	350	390	510
Height	H	375	420	425	510	575	635	635	685
Length	E	200	230	235	300	300	300	300	350
Actuator-Ø	M	dependent on actuator							
Wrench size across flats	S ₂	30	36	36	36	36	41	41	41
Weight w/o actuator	ca. kg	5.4	11.2	15.3	23.6	31.0	46.8	56.0	68.5
Kvs-Value	m ³ /h	11.5	22.6	37.1	71.1	104.0	170.0	170.0	350.0
Cv-Value	gal/min	13.4	26.3	43.2	82.7	120.9	195.2	195.2	401.8
Stroke	mm	9	11	15	23	23	30	30	40

Dimensions in mm.

Actuated Valves

Type 03323 - Actuated Globe Valve



Cryogenic-Globe Valves with Pneumatic Actuator, PN40

Stainless steel body and topwork

Actuator - air opens, spring closes or contrary

"live loaded" gland packing

"cleaned and degreased for oxygen service" - the actuator is not cleaned and degreased for oxygen

Part No. 03323.X.*012

Flanged connection acc. to DIN EN 1092-1 PN40

Available accessories:

- Solenoid valve
- Limit switch
- Electropneumatic positioner etc.

Available options - on request only:

- Actuator - "cleaned and degreased for oxygen service"
- Electric actuator
- Valve with check disc
- Valve with control disc (tapered design)
- Nominal sizes DN15, DN20 and DN150 with welded flange

Applications:

Approved for air gases, vapours and cryogenic liquefied gases incl. LNG.

Working temperature: -196°C / -321°F (77K) up to +120°C / +248°F (393K)



Materials	DIN EN	ASTM
1 Body	1.4308	A 351 CF8
2 Valve seal up to DN50	PTFE / Carbon filled (25%)	
2a Valve seal from DN65	PTFE	
3 Disc	CW614N	B 283 UNS C38500
4 Bonnet gasket	PTFE	
5 Headpiece	1.4301	A 276 Grade 304
6 Bolts	1.4301/A2	A 194 B8
7 Elongation tube	1.4541	A 213 TP 321
8 Stem	1.4301	A 276 Grade 304
9 Gland packing	Graphite / PTFE	
10 Gland nut	CW614N	B 283 UNS C38500
11 Pillars	1.4404	A 276 Grade 316L
12 Bush	CW452K	B 159 UNS C51900

Standard marking acc. to Pressure Equipment Directive 97/23/EC (PED).

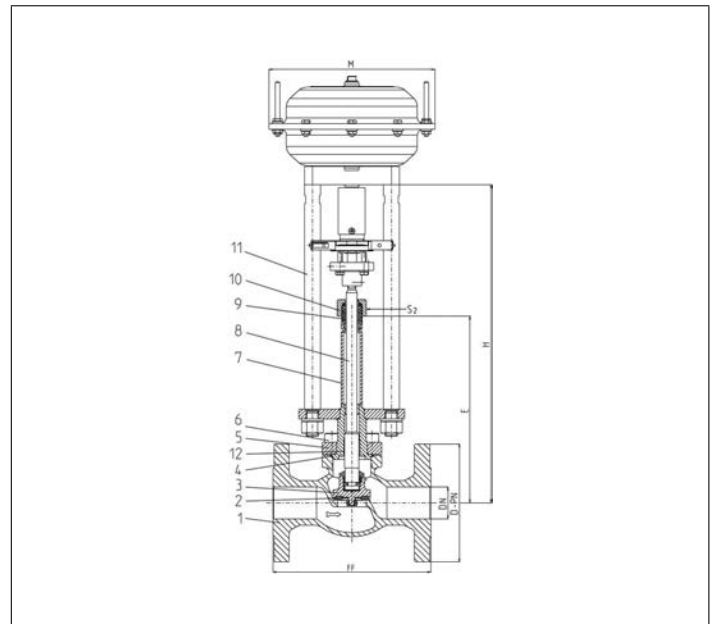

Type 03323 - Standard design	Technical data								
	DN	25	40	50	65	80	100	125	150
Nominal size	DN	25	40	50	65	80	100	125	150
Dimension code - Flange EN 1092-1 PN40	.X.	0250	0400	0500	0650	0800	1000	1250	1500
Flange-Ø	D-PN	115	150	165	185	200	235	250	300
Face-to-face dimension	FF	160	200	230	290	310	350	390	510
Height	H	375	420	425	510	575	635	635	685
Length	E	200	230	235	300	300	300	300	350
Actuator-Ø	M	dependent on actuator							
Wrench size across flats	S ₂	30	36	36	36	36	41	41	41
Weight w/o actuator	ca. kg	5.4	11.2	15.3	23.6	31.0	46.8	56.0	68.5
Kvs-Value	m ³ /h	11.5	22.6	37.1	71.1	104.0	170.0	170.0	350.0
Cv-Value	gal/min	13.4	26.3	43.2	82.7	120.9	195.2	195.2	401.8
Stroke	mm	9	11	15	23	23	30	30	40

Dimensions in mm.



Actuated Valves

Type 03323 - Actuated Globe Valve



Cryogenic-Globe Valves with Pneumatic Actuator, class 300

Stainless steel body and topwork

Actuator - air opens, spring closes or contrary

"live loaded" gland packing

"cleaned and degreased for oxygen service" - the actuator is not cleaned and degreased for oxygen

Part No. 03323.X.*013

Flanged connection acc. to ANSI B16.5 class 300

Available accessories:

- Solenoid valve
- Limit switch
- Electropneumatic positioner etc.

Available options - on request only:

- Actuator - "cleaned and degreased for oxygen service"
- Electric actuator
- Valve with check disc
- Valve with control disc (tapered design)
- Nominal sizes DN15, DN20 and DN150 with welded flange

Applications:

Approved for air gases, vapours and cryogenic liquefied gases incl. LNG.

Working temperature: -196°C / -321°F (77K) up to +120°C / +248°F (393K)



Materials	DIN EN	ASTM
1 Body	1.4308	A 351 CF8
2 Valve seal up to DN50	PTFE / Carbon filled (25%)	
2a Valve seal from DN65	PTFE	
3 Disc	CW614N	B 283 UNS C38500
4 Bonnet gasket	PTFE	
5 Headpiece	1.4301	A 276 Grade 304
6 Bolts	1.4301/A2	A 194 B8
7 Elongation tube	1.4541	A 213 TP 321
8 Stem	1.4301	A 276 Grade 304
9 Gland packing	Graphite / PTFE	
10 Gland nut	CW614N	B 283 UNS C38500
11 Pillars	1.4404	A 276 Grade 316L
12 Bush	CW452K	B 159 UNS C51900

Standard marking acc. to Pressure Equipment Directive 97/23/EC (PED).

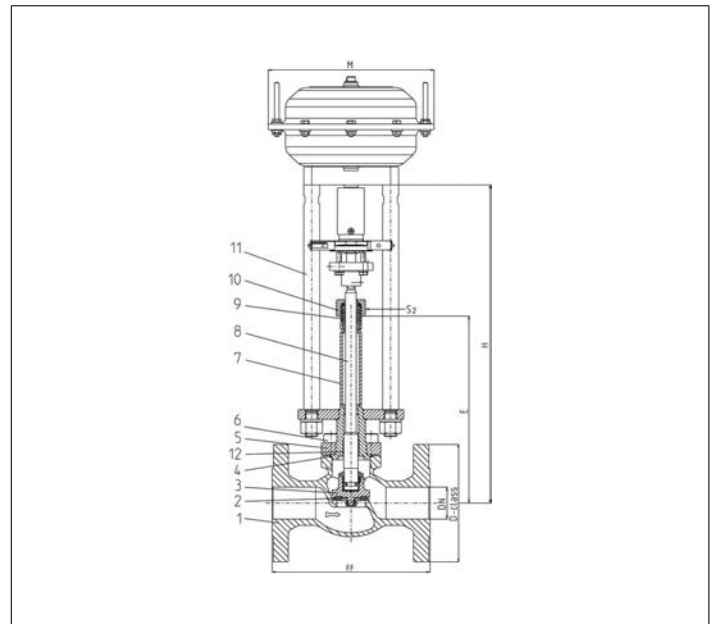

Type 03323 - Standard design	Technical data							
	DN	25	40	50	65	80	100	150
Nominal size	.X.	1000	1400	2000	2400	3000	4000	6000
Dimension code - Flange ANSI B16.5 class 300	D-class	115	150	165	185	200	235	320
Flange-Ø	FF	160	200	230	290	310	350	510
Face-to-face dimension	H	375	420	425	510	575	635	685
Height	E	200	230	235	300	300	300	350
Length	M	dependent on actuator						
Actuator-Ø	S ₂	30	36	36	36	36	41	41
Wrench size across flats	ca. kg	5.4	11.2	15.3	23.6	31.0	46.8	68.5
Weight w/o actuator	m ³ /h	11.5	22.6	37.1	71.1	104.0	170.0	350.0
Kvs-Value	gal/min	13.4	26.3	43.2	82.7	120.9	195.2	401.8
Cv-Value	mm	9	11	15	23	23	30	40
Stroke								

Dimensions in mm.

Actuated Valves

Type 03343 - Actuated Globe Valve



Cryogenic-Globe Valves with Pneumatic Actuator, PN16

Stainless steel body and topwork

Actuator - air opens, spring closes or contrary

"live loaded" gland packing

"cleaned and degreased for oxygen service" - the actuator is not cleaned and degreased for oxygen

Part No. 03343.X.*014

Flanged connection acc. to DIN EN 1092-1 PN16

Available accessories:

- Solenoid valve
- Limit switch
- Electropneumatic positioner etc.

Available options - on request only:

- Actuator - "cleaned and degreased for oxygen service"
- Electric actuator
- Valve with check disc
- Valve with control disc (tapered design)
- Nominal sizes DN15, DN20 and DN150 with welded flange

Applications:

Approved for air gases, vapours and cryogenic liquefied gases incl. LNG.

Working temperature: -196°C / -321°F (77K) up to +120°C / +248°F (393K)



Materials	DIN EN	ASTM
1 Body	1.4308	A 351 CF8
2 Valve seal up to DN50	PTFE / Carbon filled (25%)	
2a Valve seal from DN65	PTFE	
3 Disc	1.4301	A 276 Grade 304
4 Bonnet gasket	PTFE	
5 Headpiece	1.4301	A 276 Grade 304
6 Bolts	1.4301/A2	A 194 B8
7 Elongation tube	1.4541	A 213 TP 321
8 Stem	1.4301	A 276 Grade 304
9 Gland packing	Graphite / PTFE	
10 Gland nut	1.4305	A 276 Grade 303
11 Pillars	1.4404	A 276 Grade 316L
12 Bush	CW452K	B 159 UNS C51900

Standard marking acc. to Pressure Equipment Directive 97/23/EC (PED).

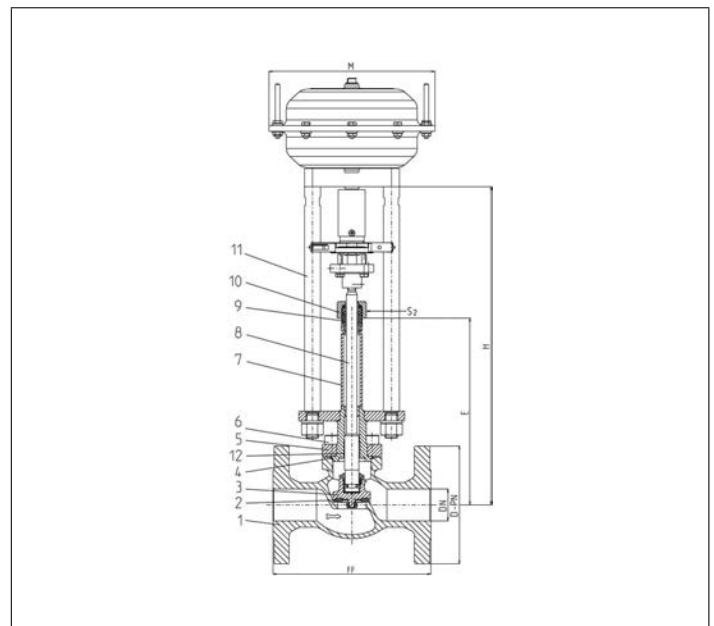

Type 03343 - Standard design	Technical data								
	DN	25	40	50	65	80	100	125	150
Nominal size	DN	25	40	50	65	80	100	125	150
Dimension code - Flange EN 1092-1 PN16	.X.	0250	0400	0500	0650	0800	1000	1250	1500
Flange-Ø	D-PN	115	150	165	185	200	235	250	285
Face-to-face dimension	FF	160	200	230	290	310	350	390	510
Height	H	375	420	425	510	575	635	635	685
Length	E	200	230	235	300	300	300	300	350
Actuator-Ø	M	dependent on actuator							
Wrench size across flats	S ₂	30	36	36	36	36	41	41	41
Weight w/o actuator	ca. kg	5.4	11.2	15.3	23.6	31.0	46.8	56.0	68.5
Kvs-Value	m ³ /h	11.5	22.6	37.1	71.1	104.0	170.0	170.0	350.0
Cv-Value	gal/min	13.4	26.3	43.2	82.7	120.9	195.2	195.2	401.8
Stroke	mm	9	11	15	23	23	30	30	40

Dimensions in mm.



Actuated Valves

Type 03343 - Actuated Globe Valve



Cryogenic-Globe Valves with Pneumatic Actuator, PN40

Stainless steel body and topwork

Actuator - air opens, spring closes or contrary

"live loaded" gland packing

"cleaned and degreased for oxygen service" - the actuator is not cleaned and degreased for oxygen

Part No. 03343.X.*012

Flanged connection acc. to DIN EN 1092-1 PN40

Available accessories:

- Solenoid valve
- Limit switch
- Electropneumatic positioner etc.

Available options - on request only:

- Actuator - "cleaned and degreased for oxygen service"
- Electric actuator
- Valve with check disc
- Valve with control disc (tapered design)
- Nominal sizes DN15, DN20 and DN150 with welded flange

Applications:

Approved for air gases, vapours and cryogenic liquefied gases incl. LNG.

Working temperature: -196°C / -321°F (77K) up to +120°C / +248°F (393K)



Materials	DIN EN	ASTM
1 Body	1.4308	A 351 CF8
2 Valve seal up to DN50	PTFE / Carbon filled (25%)	
2a Valve seal from DN65	PTFE	
3 Disc	1.4301	A 276 Grade 304
4 Bonnet gasket	PTFE	
5 Headpiece	1.4301	A 276 Grade 304
6 Bolts	1.4301/A2	A 194 B8
7 Elongation tube	1.4541	A 213 TP 321
8 Stem	1.4301	A 276 Grade 304
9 Gland packing	Graphite / PTFE	
10 Gland nut	1.4305	A 276 Grade 303
11 Pillars	1.4404	A 276 Grade 316L
12 Bush	CW452K	B 159 UNS C51900

Standard marking acc. to Pressure Equipment Directive 97/23/EC (PED).

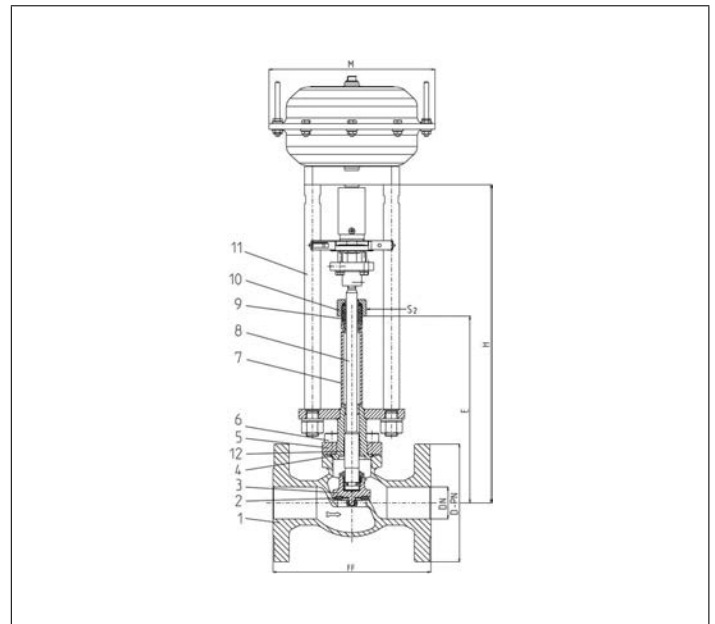

Type 03343 - Standard design	Technical data							
	DN	25	40	50	65	80	100	150
Nominal size	DN	25	40	50	65	80	100	150
Dimension code - Flange EN 1092-1 PN40	.X.	0250	0400	0500	0650	0800	1000	1500
Flange-Ø	D-PN	115	150	165	185	200	235	300
Face-to-face dimension	FF	160	200	230	290	310	350	550
Height	H	370	420	425	510	575	635	685
Length	E	200	230	235	300	300	300	300
Actuator-Ø	M	dependent on actuator						
Wrench size across flats	S ₂	30	36	36	36	36	41	41
Weight w/o actuator	ca. kg	5.4	11.2	15.3	23.6	31.0	46.8	60.9
Kvs-Value	m ³ /h	11.5	22.6	37.1	71.1	104.0	170.0	350.0
Cv-Value	gal/min	13.4	26.3	43.2	82.7	120.9	195.2	401.8
Stroke	mm	9	11	15	23	23	30	40

Dimensions in mm.

Actuated Valves

Type 03343 - Actuated Globe Valve



Cryogenic-Globe Valves with Pneumatic Actuator, class 300

Stainless steel body and topwork

Actuator - air opens, spring closes or contrary

"live loaded" gland packing

"cleaned and degreased for oxygen service" - the actuator is not cleaned and degreased for oxygen

Part No. 03343.X.*013

Flanged connection acc. to ANSI B16.5 class 300

Available accessories:

- Solenoid valve
- Limit switch
- Electropneumatic positioner etc.

Available options - on request only:

- Actuator - "cleaned and degreased for oxygen service"
- Electric actuator
- Valve with check disc
- Valve with control disc (tapered design)
- Nominal sizes DN15, DN20 and DN150 with welded flange

Applications:

Approved for air gases, vapours and cryogenic liquefied gases incl. LNG.

Working temperature: -196°C / -321°F (77K) up to +120°C / +248°F (393K)



Materials	DIN EN	ASTM
1 Body	1.4308	A 351 CF8
2 Valve seal up to DN50	PTFE / Carbon filled (25%)	
2a Valve seal from DN65	PTFE	
3 Disc	1.4301	A 276 Grade 304
4 Bonnet gasket	PTFE	
5 Headpiece	1.4301	A 276 Grade 304
6 Bolts	1.4301/A2	A 194 B8
7 Elongation tube	1.4541	A 213 TP 321
8 Stem	1.4301	A 276 Grade 304
9 Gland packing	Graphite / PTFE	
10 Gland nut	1.4305	A 276 Grade 303
11 Pillars	1.4404	A 276 Grade 316L
12 Bush	CW452K	B 159 UNS C51900

Standard marking acc. to Pressure Equipment Directive 97/23/EC (PED).

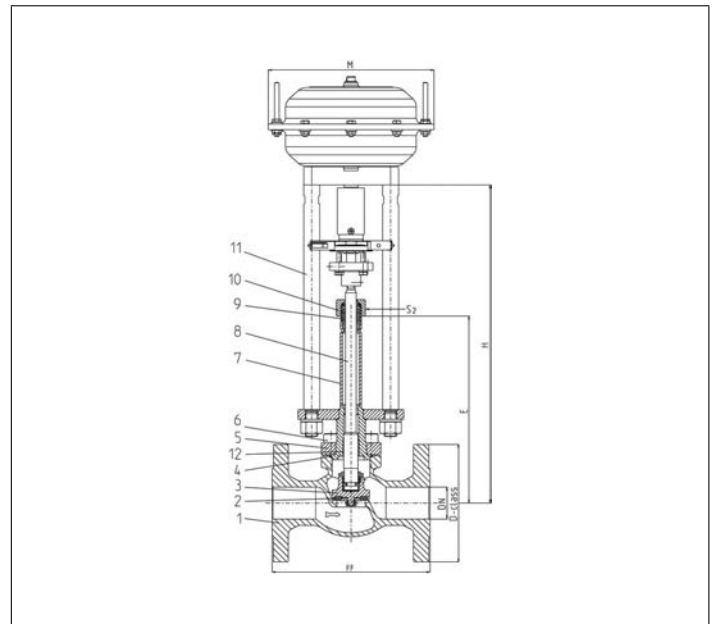

Type 03343 - Standard design	Technical data							
	DN	25	40	50	65	80	100	150
Nominal size	DN	25	40	50	65	80	100	150
Dimension code - Flange ANSI B16.5 class 300	.X.	1000	1400	2000	2400	3000	4000	6000
Flange-Ø	D-class	123.9	155.4	165	190.5	209.5	254	317.5
Face-to-face dimension	FF	160	200	230	290	310	350	597
Height	H	370	420	425	510	575	635	685
Length	E	200	230	235	300	300	300	300
Actuator-Ø	M	dependent on actuator						
Wrench size across flats	S ₂	30	36	36	36	36	41	41
Weight w/o actuator	ca. kg	5.4	11.2	15.3	23.6	31.0	46.8	60.9
Kvs-Value	m ³ /h	11.5	22.6	37.1	71.1	104.0	170.0	350.0
Cv-Value	gal/min	13.4	26.3	43.2	82.7	120.9	195.2	401.8
Stroke	mm	9	11	15	23	23	30	40

Dimensions in mm.



Actuated Valves

Type 01343 - Actuated Control Valve



Cryogenic-Control Valves with Pneumatic Actuator, PN50 (DN100=PN40)

Control characteristic: linear or equal percentage
 Stainless steel body and topwork
 Actuator - air opens, spring closes or contrary
 "live loaded" gland packing
 "cleaned and degreased for oxygen service" - the actuator is not cleaned and degreased for oxygen

Part No. 01343.X.*61*

Butt weld connection for stainless steel pipes acc. to ISO 1127 or ASTM A312

Part No. 01343.X.*614

Socket weld connection for stainless steel pipes acc. to ISO 1127 or ASTM A312

Available accessories:

- Solenoid valve · Limit switch
- Electropneumatic positioner etc.

Available options - on request only:

- Welded stainless steel stubs acc. to ISO 1127 or ASTM A312 - length FF + 200mm
- Actuator "cleaned and degreased for oxygen service"
- Electric actuator

Applications:

Approved for air gases, vapours and cryogenic liquefied gases incl. LNG.
 Working temperature: -196°C / -321°F (77K) up to +120°C / +248°F (393K)



Materials	DIN EN	ASTM
1 Body	1.4308	A 351 CF8
2 Valve seal up to DN50	PTFE / Carbon filled (25%)	
2a Valve seal from DN65	PTFE	
3 Disc	1.4301	A 276 Grade 304
4 Bonnet gasket	PTFE	
5 Headpiece	1.4301	A 276 Grade 304
6 Bolts	1.4301/A2	A 194 B8
7 Elongation tube	1.4541	A 213 TP 321
8 Stem	1.4301	A 276 Grade 304
9 Gland packing	Graphite / PTFE	
10 Gland nut	1.4305	A 276 Grade 303
11 Pillars	1.4404	A 276 Grade 316L
12 Bush	CW452K	B 159 UNS C51900

Standard marking acc. to Pressure Equipment Directive 97/23/EC (PED).

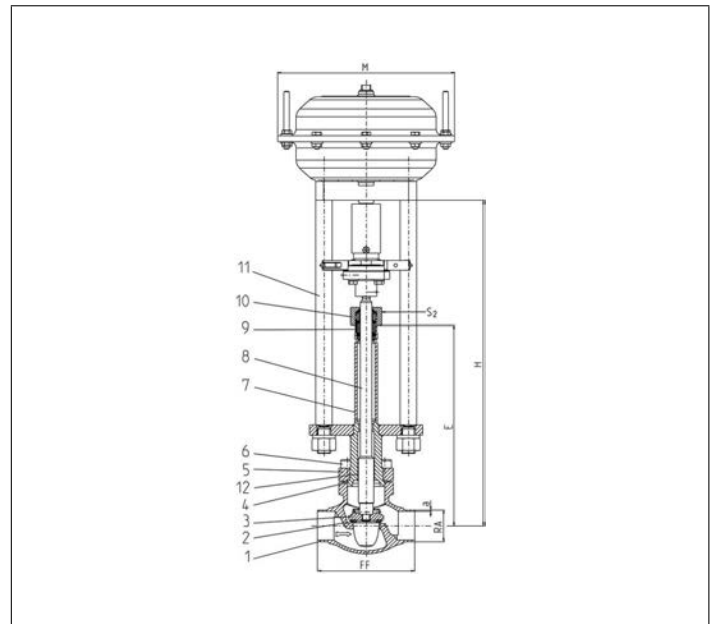

Type 01343 - Standard design	Technical data										
Nominal size	DN	15	20	25	32	40	50	65	80	100	
Dimension code	.X.	1521	2026	2533	3238	4048	5060	657x	8088	0114	
Face-to-face dimension	FF	85	100	115	115	130	155	205	245	280	
Height	H	370	370	375	405	420	425	510	575	635	
Length	E	195	200	200	230	230	235	300	300	300	
Outside pipe-Ø ISO 1127	RA	21.3	26.9	33.7	38.0	48.3	60.3	76.1	88.9	114.3	
Wall thickness pipe ISO 1127	a	2.0	2.0	2.0	2.0	2.0	2.0	2.6	3.2	6.0	
Outside pipe-Ø ASTM A312	RA	21.34	26.67	33.4	-	48.26	60.33	73.03	88.90	114.3	
Wall thickness pipe ASTM A312	a	dimensions acc. to S10 or S40									
Socket depth	b	10	13	13	-	13	16	16	16	20	
Actuator-Ø	M										
Wrench size across flats	S ₂	30	30	30	36	36	36	36	36	41	
Weight w/o actuator	ca. kg	2.2	2.4	3.1	3.8	6.5	9.0	15.2	20.0	28.0	
Stroke	mm	20	20	20	30	40	30	40	40	40	

Dimensions in mm.

Flow coefficient for Control Valves - Control characteristic linear Kvs-Value in m³/h, Cv-Value in gal/min

Type 01343 Control valve																		
Lift in mm	20	20	20	20	20	20	30	30	30	30	30	30	40	40	40	40	40	40
Seat-Ø in mm	15	15	20	20	25	25	32	32	36	36	45	45	62	62	76	76	94	94
Nominal size	Kvs	Cv	Kvs	Cv	Kvs	Cv	Kvs	Cv	Kvs	Cv	Kvs	Cv	Kvs	Cv	Kvs	Cv	Kvs	Cv
DN 15	3.5	4.0																
DN 20			6.3	7.3														
DN 25					10.0	11.6												
DN 32							16.0	18.5										
DN 40									19.0	22.0								
DN 50											30.0	34.7						
DN 65													60.0	69.3				
DN 80															86.0	99.4		
DN 100																	140.0	161.8

Ideal inherent linear characteristic line acc. to DIN IEC 60534 Part 2-4

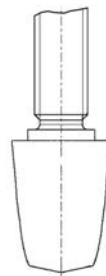
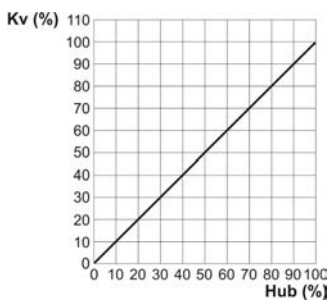

Sample drawing cone, control characteristic linear

Flow coefficient for Control Valves - Control characteristic equal percentage Kvs-Value in m³/h, Cv-Value in gal/min

Type 01343 Control valve																		
Lift in mm	20	20	20	20	20	20	30	30	30	30	30	30	40	40	40	40	40	40
Seat-Ø in mm	15	15	20	20	25	25	32	32	36	36	45	45	62	62	76	76	94	94
Nominal size	Kvs	Cv	Kvs	Cv	Kvs	Cv	Kvs	Cv	Kvs	Cv	Kvs	Cv	Kvs	Cv	Kvs	Cv	Kvs	Cv
DN 15	3.5	4.0																
DN 20			4.0	4.6														
DN 20			6.0	6.9														
DN 25					2.5	2.9												
DN 25					4.5	5.2												
DN 25					6.3	7.3												
DN 25					10.0	11.6												
DN 32							10.0	11.6										
DN 32							14.0	16.2										
DN 40									10.0	11.6								
DN 40									19.0	22.0								
DN 50											10.0	11.6						
DN 50											16.0	18.5						
DN 50											25.0	28.9						
DN 50											30.0	34.7						
DN 65													60.0	69.3				
DN 80															80.0	92.5		
DN 100																	130.0	150.3

Ideal inherent equal percentage characteristic curve acc. to DIN IEC 60534 Part 2-4

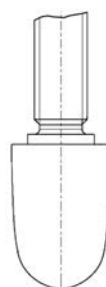
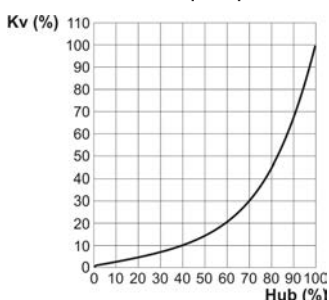

Sample drawing cone, control characteristic equal percentage

Actuated Valves

Type 27100 - Electric Actuator



Electric Actuators for Globe and Control Valves

mechanical position indicator, with emergency handwheel, protection class IP 65 (DIN VDE 0470)

power supply 24 V, 115 V, 230 V, 50/60 Hz (please indicate on purchase order)

Mounting position: any, except upside down!

Part No. 27100.5112.3200 (also available with power supply 24 V DC)

2x force switch - directly wired, 2x limit switch - directly wired

Part No. 27100.5113.3500

2x limit switch - directly wired

Part No. 27100.5114.1700

limit switch: 2x Dremo switch und 1x limit end switch

Available options - on request only:

- potentiometer
- position indicator or digital positioner

Ambient temperature limit: -20°C / -4°F (253K) up to +60°C / 140°F (333K)

Overview - required actuator sizes for differential pressures

Valve size	Differential pressure in bar												
	0	3.1	5.1	7.1	10.1	14.1	17.1	19.1	21.1	25.1	27.1	43.1	46.1
	3.0	5.0	7.0	10.0	14.0	17.0	19.0	21.0	25.0	27.0	43.0	46.0	50.0
DN 10	A	A	A	A	A	A	A	A	A	A	A	A	A
DN 15	A	A	A	A	A	A	A	A	A	A	A	A	A
DN 20	A	A	A	A	A	A	A	A	A	A	A	A	A
DN 25	A	A	A	A	A	A	A	A	A	A	A	B	B
DN 32	A	A	A	A	A	A	A	A	A	A	B	B	B
DN 40	A	A	A	A	A	A	A	A	B	B	B	C	C
DN 50	A	A	A	A	A	B	B	B	B	B	C	C	o.r.
DN 65	C	C	C	C	C	C	C	C	C	o.r. - on request			
DN 80	C	C	C	C	C	C	o.r. - on request						
DN 100	C	C	C	C	o.r. - on request								
DN 150	C	C	o.r. - on request										



Code in Table	Part No.	Actuator
A	27100.5112.3200	
B	27100.5113.3500	
C	27100.5114.1700	

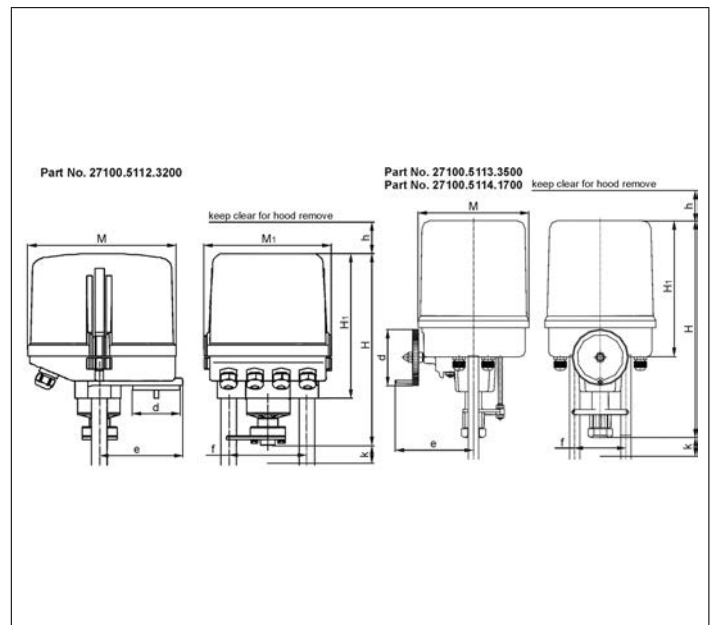

Type 27100	Technical Data			
Part No. Actuator:		.5112.3200	.5113.3500	5114.1700
Diameter Actuator	M	191	216	216
Diameter Actuator	M1	164	-	-
Height	H	275	390	380
Height	H1	206	265	265
Height	h	130	200	200
Lift	k	40	60	80
Length	e	108	155	155

Type 27100	Technical Data			
Part No. Actuator:		.5112.3200	.5113.3500	5114.1700
Diameter	d	60	100	100
Operational force	kN	2.8	6.0	10.0
Operational speed	mm/s	0.26	0.44	0.88
Power consumption	VA	11	46	80
Cable glands		4x M16	4x M20	4x M20
Length	f	100	100	100
Weight	ca. kg	5.0	10.0	10.3

Abmessungen in mm.

Actuated Valves

Type 27511 - Pneumatic Actuator - Globe Valve (on/off)



Pneumatic Actuators for Globe Valves (on/off)

Actuator - air to open, **spring to close**
 maximum air pressure for operation 6.0 bar g
 Actuator coating outside - Epoxy resin

Available options - on request only:
 · Pneumatic actuator with override handwheel

Ambient temperature limit: -20°C / -4°F (253K) up to +80°C / 176°F (353K)



Overview - required actuator sizes for differential pressures

Valve-size	Differential pressure in bar												
	0	3.1	4.1	7.1	10.1	11.1	15.1	18.1	20.1	22.1	30.1	33.1	35.1
	3.0	4.0	7.0	10.0	11.0	15.0	18.0	20.0	22.0	30.0	33.0	35.0	50.0
DN 10	A	A	A	A	A	A	A	A	A	A	A	A	A
DN 15	A	A	A	A	A	A	A	A	A	A	A	A	A
DN 20	A	A	A	A	A	A	A	A	A	A	B	B	B
DN 25	A	A	A	A	A	A	A	A	B	B	B	B	B
DN 32	A	A	A	A	A	B	B	B	B	B	B	B	C
DN 40	B	B	B	B	B	B	B	B	C	C	C	C	C
DN 50	B	B	B	B	B	B	C	C	C	C	C	C	D
DN 65	B	B	B	C	C	C	C	D	E	E	E	F	F
DN 80	B	B	C	C	D	E	E	E	E	F	F	F	G
DN 100	B	C	D	E	E	F	F	F	F	G	o.r. - on request		
DN 150	D	E	F	G	o.r. - on request								

Code in Table	Part No.	Actuator
A	27511.15A6.3SPO	
B	27511.35B6.6GPO	
C	27511.60A6.6GPO	
D	27511.60C6.7GPO	
E	27511.75B6.3DPO	
F	27511.75B6.5DPO	
G	27511.75B6.7DPO	

Materials	DIN EN	ASTM
1 Body	1.0333	A 619 Grade 1008
2 Body	1.0333	A 619 Grade 1008
3 Diaphragm	NBR	
4 Springs	1.1200	A 576 Grade 1045
5 Actuator stem	1.4301	A 276 Grade 304
6 Coupling	CC333G	B 148 UNS C95800

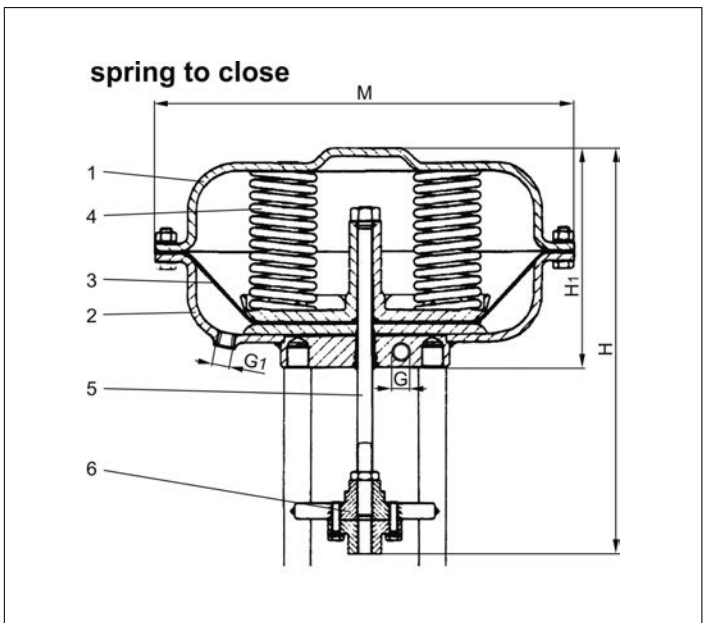

Type 27511 Part No. Actuator	Technical data							
	27511							
		.15A6.3SPO	.35B6.6GPO	.60A6.6GPO	.60C6.7GPO	.75B6.3DPO	.75B6.5DPO	.75B6.7DPO
Diameter Actuator	M	162	210	310	310	430	430	430
Height	H	256	276	309	352	353	353	353
Height	H1	116	136	166	186	234	234	234
Thread	G	G1/8" with Ermeto-Fitting L8	-	-	-	-	-	-
Thread	G1	-	1/4" NPT	1/4" NPT	1/4" NPT	1/4" NPT	1/4" NPT	1/4" NPT
Diaphragm area	cm ²	120	280	530	530	1000	1000	1000
Spring range	bar	0.9 - 2.0	0.8 - 3.0	0.8 - 2.8	0.7 - 3.0	0.7 - 2.1	1.2 - 3.4	1.6 - 4.7
Regulating lift	mm	20	35	40	60	60	60	60
Weight	ca. kg	3.0	5.0	12.5	14.0	37.0	39.0	41.0

Dimensions in mm.



Actuated Valves

Type 27511 - Pneumatic Actuator - Control Valve



Pneumatic Actuators for Control Valves

Actuator - air to open, **spring to close**
 maximum air pressure for operation 6.0 bar g
 Actuator coating outside - Epoxy resin

Available options - on request only:
 · Pneumatic actuator with override handwheel

Ambient temperature limit: -20°C / -4°F (253K) up to +80°C / 176°F (353K)

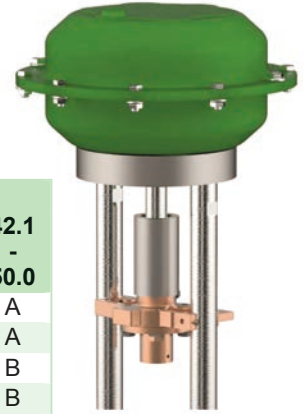

Overview - required actuator sizes for differential pressures

Valve size	Differential pressure in bar															
	0	2.1	4.1	6.1	8.1	10.1	12.1	15.1	17.1	19.1	22.1	25.1	29.1	35.1	39.1	42.1
	2.0	4.0	6.0	8.0	10.0	12.0	15.0	17.0	19.0	22.0	25.0	29.0	35.0	39.0	42.0	50.0
DN 10	A	A	A	A	A	A	A	A	A	A	A	A	A	A	A	A
DN 15	A	A	A	A	A	A	A	A	A	A	A	A	A	A	A	A
DN 20	A	A	A	A	A	A	A	A	A	A	A	B	B	B	B	B
DN 25	A	A	A	A	A	A	A	A	B	B	B	B	B	B	B	B
DN 32	B	B	B	B	B	B	B	B	B	B	C	C	C	C	C	C
DN 40	B	B	B	B	B	B	B	C	C	C	C	C	C	C	D	D
DN 50	B	B	B	B	B	C	C	C	C	C	C	D	D	E	E	E
DN 65	C	C	D	C	C	C	D	E	E	E	E	E	F	F	F	G
DN 80	C	C	C	D	E	E	E	E	F	F	F	F	G	G	o.r.	
DN 100	C	C	D	E	E	F	F	F	F	G	G	o.r. - on request				
DN 150	D	E	F	F	G	o.r. - on request										

Code in Table	Part No.	Actuator
A	27511.15A6.3SPO	
B	27511.35B6.6GPO	
C	27511.60A6.6GPO	
D	27511.60C6.7GPO	
E	27511.75B6.3DPO	
F	27511.75B6.5DPO	
G	27511.75B6.7DPO	

Materials	DIN EN	ASTM
1 Body	1.0333	A 619 Grade 1008
2 Body	1.0333	A 619 Grade 1008
3 Diaphragm	NBR	
4 Springs	1.1200	A 576 Grade 1045
5 Actuator stem	1.4301	A 276 Grade 304
6 Coupling	CC333G	B 148 UNS C95800

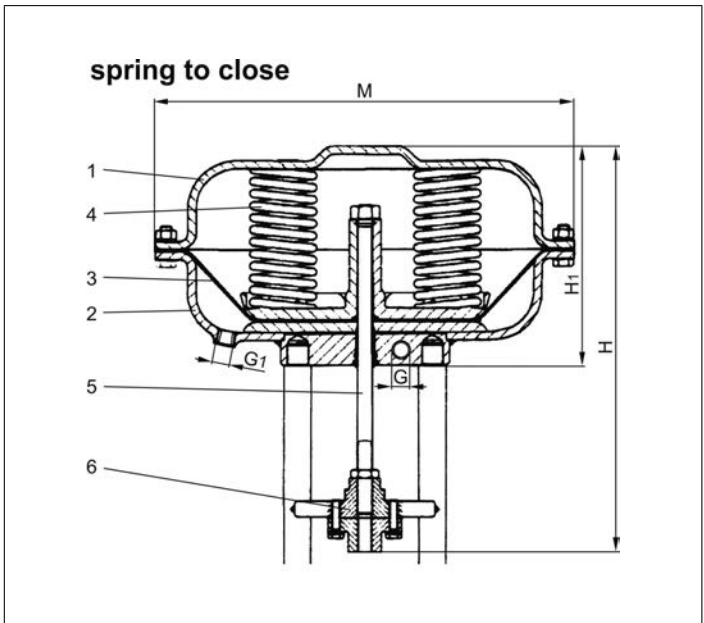

Type 27511 Part No. Actuator	Technical data	27511						
		.15A6.3SPO	.35B6.6GPO	.60A6.6GPO	.60C6.7GPO	.75B6.3DPO	.75B6.5DPO	.75B6.7DPO
Diameter Actuator	M	162	210	310	310	430	430	430
Height	H	256	276	309	352	353	353	353
Height	H1	116	136	166	186	234	234	234
Thread	G	G1/8" with Ermeto-Fitting L8	-	-	-	-	-	-
Thread	G1	-	1/4" NPT	1/4" NPT	1/4" NPT	1/4" NPT	1/4" NPT	1/4" NPT
Diaphragm area	cm ²	120	280	530	530	1000	1000	1000
Spring range	bar	0.9 - 2.0	0.8 - 3.0	0.8 - 2.8	0.7 - 3.0	0.7 - 2.1	1.2 - 3.4	1.6 - 4.7
Regulating lift	mm	20	35	40	60	60	60	60
Weight	ca. kg	3.0	5.0	12.5	14.0	37.0	39.0	41.0

Dimensions in mm.

Actuated Valves

Type 27512 - Pneumatic Actuator - Globe Valve (on/off)



Pneumatic Actuators for Globe Valves (on/off)

Actuator - **spring to open**, air to close
 maximum air pressure for operation 6.0 bar g
 Actuator coating outside - Epoxy resin

Available options - on request only:
 · Pneumatic actuator with override handwheel

Ambient temperature limit: -20°C / -4°F (253K) up to +80°C / 176°F (353K)

Overview - required actuator sizes for differential pressures

Valve size	Differential pressure in bar											
	0	5.1	7.1	14.1	17.1	19.1	22.1	26.1	29.1	35.1	37.1	45.1
	5.0	7.0	14.0	17.0	19.0	22.0	26.0	29.0	35.0	37.0	45.0	50.0
DN 10	A	A	A	A	A	A	A	A	A	A	A	A
DN 15	A	A	A	A	A	A	A	A	A	A	A	A
DN 20	A	A	A	A	A	A	A	A	A	A	A	A
DN 25	A	A	A	A	A	A	A	A	A	A	A	A
DN 32	A	A	A	A	A	A	A	A	A	B	C	C
DN 40	A	A	A	A	A	A	A	B	C	C	C	C
DN 50	A	A	A	A	B	C	C	C	C	C	C	C
DN 65	B	B	B	C	C	C	C	C	C	C	D	E
DN 80	B	B	C	C	C	C	D	E	E	E	E	E
DN 100	B	C	C	D	E	E	E	E	E	E	E	E
DN 150	D	E	E	E	E	E						

o.r. - on request



Code in Table	Part No.	Actuator
A	27512.15A6.3SPS	
B	27512.35B6.6GPS	
C	27512.60A6.6GPS	
D	27512.60C6.7GPS	
E	27512.75B6.2SPS	

Materials	DIN EN	ASTM
1 Body	1.0333	A 619 Grade 1008
2 Body	1.0333	A 619 Grade 1008
3 Diaphragm	NBR	
4 Springs	1.1200	A 576 Grade 1045
5 Actuator stem	1.4301	A 276 Grade 304
6 Coupling	CC333G	B 148 UNS C95800

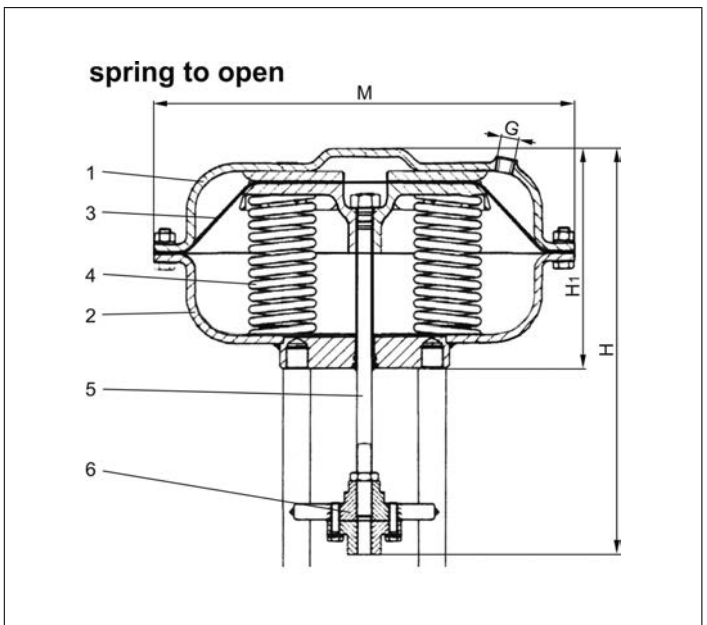

Type 27512		Technical data				
Part No.	Actuator	27512				
		.15A6.3SPS	.35B6.6GPS	.60A6.6GPS	.60C6.7GPS	.75B6.2SPS
Diameter Actuator	M	162	210	310	310	430
Height	H	256	276	309	352	353
Height	H1	116	136	166	186	234
Thread	G	1/4" NPT	1/4" NPT	1/4" NPT	1/4" NPT	1/4" NPT
Diaphragm area	cm ²	120	280	530	530	1000
Spring range	bar	0.9 - 2.0	0.8 - 3.0	0.8 - 2.8	0.7 - 3.0	0.3 - 0.9
Regulating lift	mm	20	35	40	60	60
Weight	ca. kg	3.0	5.0	12.5	14.0	37.0

Dimensions in mm.

Actuated Valves

Type 27512 - Pneumatic Actuator - Control Valve



Pneumatic Actuators for Control Valves

Actuator - **spring to open**, air to close
 maximum air pressure for operation 6.0 bar g
 Actuator coating outside - Epoxy resin

Available options - on request only:
 · Pneumatic actuator with override handwheel

Ambient temperature limit: -20°C / -4°F (253K) up to +80°C / 176°F (353K)

Overview - required actuator sizes for differential pressures

Valve size	Differential pressure in bar								
	0	5.1	13.1	15.1	21.1	23.1	29.1	34.1	37.1
	5.0	13.0	15.0	21.0	23.0	29.0	34.0	37.0	50.0
DN 10	A	A	A	A	A	A	A	A	A
DN 15	A	A	A	A	A	A	A	A	A
DN 20	A	A	A	A	A	A	A	A	A
DN 25	A	A	A	A	A	A	A	A	A
DN 32	B	B	B	B	B	B	B	B	C
DN 40	B	B	B	B	B	B	B	C	C
DN 50	B	B	B	B	C	C	C	C	C
DN 65	C	C	C	C	C	C	C	E	E
DN 80	C	C	C	C	D	E	E	E	E
DN 100	C	C	D	E	E	E	E	E	E
DN 150	D	E	E	E	E	o.r. - on request			



Code in Table	Part No.	Actuator
A	27512.15A6.3SPS	
B	27512.35B6.6GPS	
C	27512.60A6.6GPS	
D	27512.60C6.7GPS	
E	27512.75B6.2SPS	

Materials	DIN EN	ASTM
1 Body	1.0333	A 619 Grade 1008
2 Body	1.0333	A 619 Grade 1008
3 Diaphragm	NBR	
4 Springs	1.1200	A 576 Grade 1045
5 Actuator stem	1.4301	A 276 Grade 304
6 Coupling	CC333G	B 148 UNS C95800

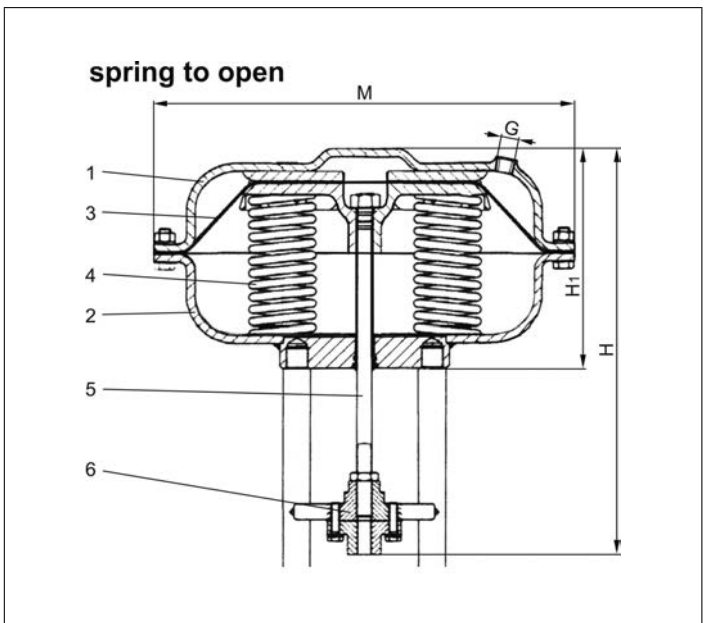

Type 27512		Technical data				
Part No.	Actuator	27512				
		.15A6.3SPS	.35B6.6GPS	.60A6.6GPS	.60C6.7GPS	.75B6.2SPS
Diameter Actuator	M	162	210	310	310	430
Height	H	256	276	309	352	353
Height	H1	116	136	166	186	234
Thread	G	1/4" NPT	1/4" NPT	1/4" NPT	1/4" NPT	1/4" NPT
Diaphragm area	cm ²	120	280	530	530	1000
Spring range	bar	0.9 - 2.0	0.8 - 3.0	0.8 - 2.8	0.7 - 3.0	0.3 - 0.9
Regulating lift	mm	20	35	40	60	60
Weight	ca. kg	3.0	5.0	12.5	14.0	37.0

Dimensions in mm.

Actuated Valves

Type 27514 - Pneumatic Actuator - Globe Valve (on/off)



Pneumatic Actuators for Globe Valves (on/off)

Actuator - air to open, **spring to close**

maximum air pressure for operation 6.0 bar

Actuator coating: Delta Seal GZ (silver-grey)

Corrosion-protection class C5-M acc. to DIN EN ISO 12944

Available options - on request only:

· Pneumatic actuator with override handwheel

Ambient temperature limit: -40°C / -40°F (233K) up to +100°C / 212°F (373K)

Overview - required actuator sizes for differential pressures

Valve size	Differential pressure in bar											
	0	6.1	10.1	12.1	14.1	18.1	26.1	29.1	33.1	37.1	45.1	48.1
	6.0	10.0	12.0	14.0	18.0	26.0	29.0	33.0	37.0	45.0	48.0	50.0
DN 10	A	A	A	A	A	A	A	A	A	A	A	A
DN 15	A	A	A	A	A	A	A	A	A	A	A	A
DN 20	A	A	A	A	A	A	A	A	A	A	A	A
DN 25	A	A	A	A	A	A	A	A	A	B	B	B
DN 32	A	A	A	A	A	A	B	B	B	C	C	C
DN 40	A	A	A	A	B	B	C	C	C	C	D	D
DN 50	A	A	B	B	C	C	D	D	D	D	D	D
DN 65	D	D	D	D	D	D	D	E	E	E	F	F
DN 80	D	D	D	D	E	E	E	E	F	F	F	F
DN 100	D	D	E	E	E	F	F	F	G	G	G	G
DN 150	E	F	F	G	G	H	H	o.r. - on request				



Code in Table	Part No.	Actuator
A	27514.DP30.2022	
B	27514.DP32.2008	
C	27514.DP32.2020	
D	27514.DP33.3020	
E	27514.DP34.5015	
F	27514.DP34.5020	
G	27514.DP34.T0PO	(Tandem - Actuator)
H	27514.DP34.TRPO	(Triple - Actuator)

Materials	DIN EN	ASTM
1 Body	1.0335	A 622 Grade 1008
2 Diaphragm	NBR + tissue	
3 Springs	1.4310	A 313 Grade 301
4 Actuator stem	1.4571	A 276 Grade 316Ti
5 Coupling	1.4571	A 276 Grade 316Ti

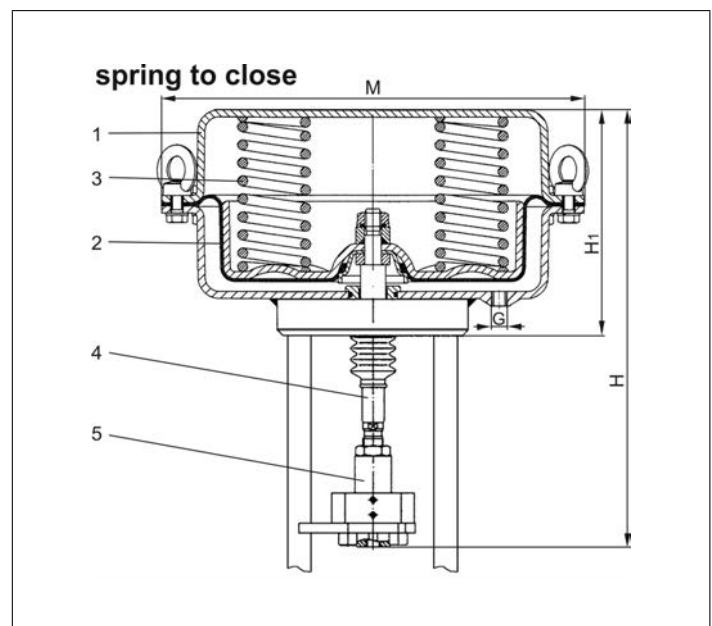

Type 27514		Technical data							
Part No.	Actuator	27514							
		.DP30.2022	.DP32.2008	.DP32.2020	.DP33.3020	.DP34.5015	.DP34.5020	.DP34.T0PO (Tandem)	.DP34.TRPO (Triple)
Diameter Actuator	M	168	250	250	300	405	405	405	405
Height	H	ca. 244	ca. 240	ca. 240	ca. 300	ca. 375	ca. 375	ca. 635	ca. 884
Height	H1	122	124	124	166	228	228	450	672
Thread	G	G 1/4"	G 1/4"	G 1/4"	G 1/4"	G 3/8"	G 3/8"	G 3/8"	G 1/2"
Diaphragm area	cm ²	80	250	250	400	800	800	1600 (2x800)	2400 (3x800)
Spring range	bar	2.2 - 4.5	0.8 - 2.4	2.0 - 3.8	2.0 - 4.0	1.5 - 3.0	2.0 - 4.0	2.0 - 4.0	2.0 - 4.0
Regulating lift	mm	20	20	20	30	50	50	50	65
Weight	ca. kg	5.0	9.0	9.0	15.0	45.0	45.0	116.0	150.0

Dimensions in mm.

Actuated Valves

Type 27514 - Pneumatic Actuator - Control Valve



Pneumatic Actuators for Control Valves

Actuator - air to open, **spring to close**

maximum air pressure for operation 6.0 bar

Actuator coating: Delta Seal GZ (silver-grey)

Corrosion-protection class C5-M acc. to DIN EN ISO 12944

Available options - on request only:

- Pneumatic actuator with override handwheel

Ambient temperature limit: -40°C / -40°F (233K) up to +100°C / 212°F (373K)

Overview - required actuator sizes for differential pressures

Valve size	Differential pressure in bar									
	0	6.1	10.1	14.1	17.1	25.1	28.1	35.1	40.1	46.1
	-	-	-	-	-	-	-	-	-	-
	6.0	10.0	14.0	17.0	25.0	28.0	35.0	40.0	46.0	50.0
DN 10	A	A	A	A	A	A	A	A	A	A
DN 15	A	A	A	A	A	A	A	A	A	A
DN 20	A	A	A	A	A	A	A	B	B	C
DN 25	A	A	A	A	A	B	C	C	C	C
DN 32	D	D	D	D	D	D	D	D	D	D
DN 40	D	D	D	D	D	D	D	D	D	D
DN 50	D	D	D	D	D	D	D	D	D	D
DN 65	E	E	E	E	E	E	E	E	F	F
DN 80	E	E	E	E	E	F	F	G	G	G
DN 100	E	E	E	E	F	G	G	G	G	H
DN 150	E	F	G	H	H	o.r. - on request				



Code in Table	Part No.	Actuator
A	27514.DP30.2022	
B	27514.DP32.2008	
C	27514.DP32.2020	
D	27514.DP33.3020	
E	27514.DP34.5015	
F	27514.DP34.5020	
G	27514.DP34.T0PO	(Tandem - Actuator)
H	27514.DP34.TRPO	(Triple - Actuator)

Materials	DIN EN	ASTM
1 Body	1.0335	A 622 Grade 1008
2 Diaphragm	NBR + tissue	
3 Springs	1.4310	A 313 Grade 301
4 Actuator stem	1.4571	A 276 Grade 316Ti
5 Coupling	1.4571	A 276 Grade 316Ti

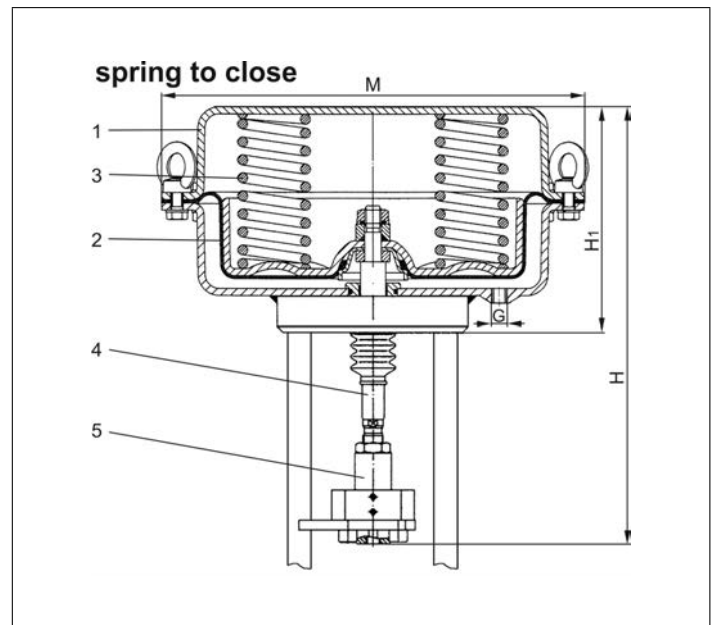

Type 27514		Technical data							
Part No.	Actuator	27514							
		.DP30.2022	.DP32.2008	.DP32.2020	.DP33.3020	.DP34.5015	.DP34.5020	.DP34.T0PO (Tandem)	.DP34.TRPO (Triple)
Diameter Actuator	M	168	250	250	300	405	405	405	405
Height	H	ca. 244	ca. 240	ca. 240	ca. 300	ca. 375	ca. 375	ca. 635	ca. 884
Height	H1	122	124	124	166	228	228	450	672
Thread	G	G 1/4"	G 1/4"	G 1/4"	G 1/4"	G 3/8"	G 3/8"	G 3/8"	G 1/2"
Diaphragm area	cm ²	80	250	250	400	800	800	1600 (2x800)	2400 (3x800)
Spring range	bar	2.2 - 4.5	0.8 - 2.4	2.0 - 3.8	2.0 - 4.0	1.5 - 3.0	2.0 - 4.0	2.0 - 4.0	2.0 - 4.0
Regulating lift	mm	20	20	20	30	50	50	50	65
Weight	ca. kg	5.0	9.0	9.0	15.0	45.0	45.0	116.0	150.0

Dimensions in mm.

Actuated Valves

Type 27515 - Pneumatic Actuator - Globe Valve (on/off)



Pneumatic Actuators for Globe Valves (on/off)

Actuator - **spring to open**, air to close
 maximum air pressure for operation 6.0 bar
 Actuator coating: Delta Seal GZ (silver-grey)

Corrosion-protection class C5-M acc. to DIN EN ISO 12944
 Available options - on request only:

· Pneumatic actuator with override handwheel

Ambient temperature limit: -40°C / -40°F (233K) up to +100°C / 212°F (373K)

Overview - required actuator sizes for differential pressures

Valve size	Differential pressure in bar						
	0	13.1	18.1	20.1	25.1	35.1	45.1
	-	-	-	-	-	-	-
	13.0	18.0	20.0	25.0	35.0	45.0	50.0
DN 10	A	A	A	A	A	A	A
DN 15	A	A	A	A	A	A	A
DN 20	A	A	A	A	A	A	A
DN 25	A	A	A	A	A	A	B
DN 32	A	A	A	A	B	B	B
DN 40	A	A	A	B	B	B	B
DN 50	A	B	B	B	B	B	B
DN 65	B	B	B	B	B	C	C
DN 80	B	B	B	C	C	D	D
DN 100	B	C	C	D	D	D	o.r.
DN 150	D	D	D	o.r. - on request			



Code in Table	Part No.	Actuator
A	27515.DP30.2S06	
B	27515.DP32.3S02	
C	27515.DP33.3S02	
D	27515.DP34.5S02	

Materials	DIN EN	ASTM
1 Body	1.0335	A 622 Grade 1008
2 Diaphragm	NBR + tissue	
3 Springs	1.4310	A 313 Grade 301
4 Actuator stem	1.4571	A 276 Grade 316Ti
5 Coupling	1.4571	A 276 Grade 316Ti

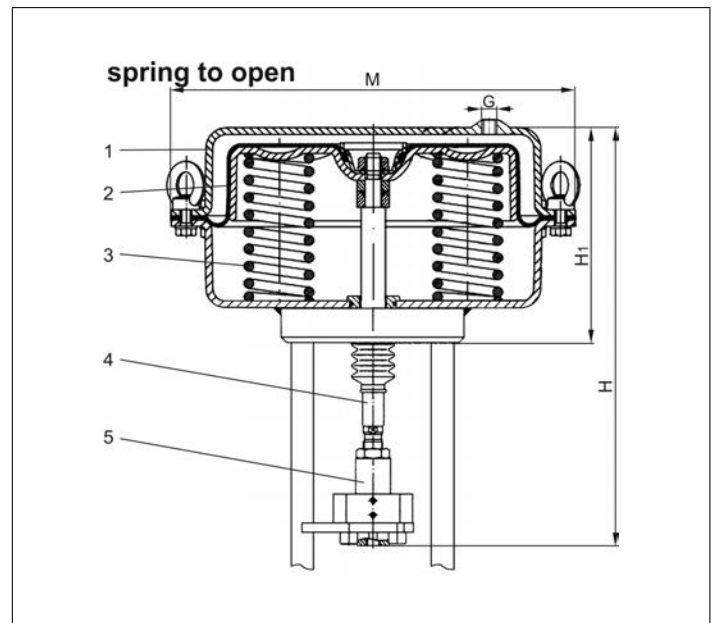

Type 27515	Technical data				
Part No. Actuator	27515				
	.DP30.2S06	.DP32.3S02	.DP33.3S02	.DP34.5S02	
Diameter Actuator	M	168	250	300	405
Height	H	ca. 244	ca. 240	ca. 300	ca. 375
Height	H1	122	124	166	228
Thread	G	G 1/4"	G 1/4"	G 1/4"	G 3/8"
Diaphragm area	cm ²	80	250	400	800
Spring range	bar	0.6 - 1.5	0.2 - 1.0	0.2 - 1.0	0.2 - 1.0
Regulating lift	mm	20	30	30	50
Weight	ca. kg	5.0	9.0	15.0	45.0

Dimensions in mm.



Actuated Valves

Type 27515 - Pneumatic Actuator - Control Valve



Pneumatic Actuators for Control Valves

Actuator - **spring to open**, air to close
 maximum air pressure for operation 6.0 bar
 Actuator coating: Delta Seal GZ (silver-grey)

Corrosion-protection class C5-M acc. to DIN EN ISO 12944
 Available options - on request only:

· Pneumatic actuator with override handwheel

Ambient temperature limit: -40°C / -40°F (233K) up to +100°C / 212°F (373K)

Overview - required actuator sizes for differential pressures

Valve size	Differential pressure in bar		
	0	21.1	45.1
	-	-	-
	21.0	45.0	50.0
DN 10	A	A	A
DN 15	A	A	A
DN 20	A	A	A
DN 25	A	A	B
DN 32	B	B	B
DN 40	B	B	B
DN 50	B	B	B
DN 65	D	D	D
DN 80	D	D	D
DN 100	D	D	o.r.
DN 150	D	o.r. - on request	



Code in Table	Part No.	Actuator
A	27515.DP30.2S06	
B	27515.DP32.3S02	
C	27515.DP33.3S02	
D	27515.DP34.5S02	

Materials	DIN EN	ASTM
1 Body	1.0335	A 622 Grade 1008
2 Diaphragm	NBR + tissue	
3 Springs	1.4310	A 313 Grade 301
4 Actuator stem	1.4571	A 276 Grade 316Ti
5 Coupling	1.4571	A 276 Grade 316Ti

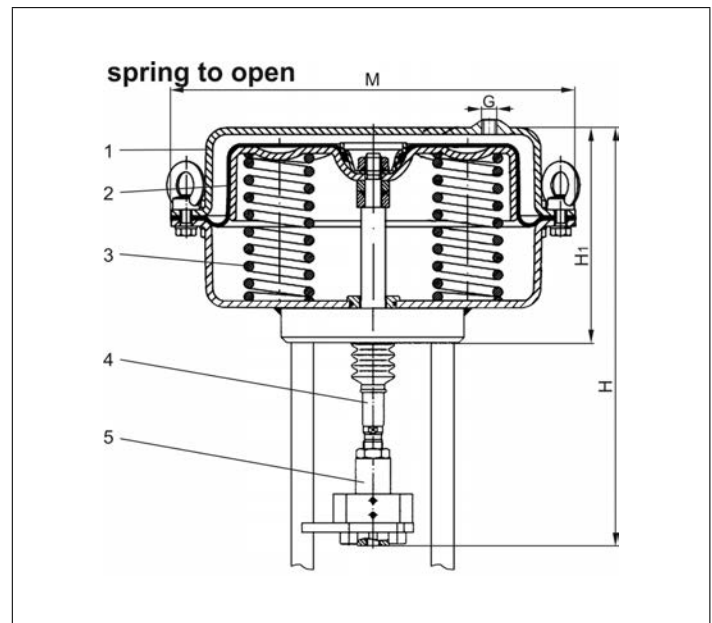

Type 27515	Technical data				
Part No. Actuator	27515				
	.DP30.2S06	.DP32.3S02	.DP33.3S02	.DP34.5S02	
Diameter Actuator	M	168	250	300	405
Height	H	ca. 244	ca. 240	ca. 300	ca. 375
Height	H1	122	124	166	228
Thread	G	G 1/4"	G 1/4"	G 1/4"	G 3/8"
Diaphragm area	cm ²	80	250	400	800
Spring range	bar	0.6 - 1.5	0.2 - 1.0	0.2 - 1.0	0.2 - 1.0
Regulating lift	mm	20	30	30	50
Weight	ca. kg	5.0	9.0	15.0	45.0

Dimensions in mm.

Actuated Valves

Type 01353 - Actuated Trailervalue



Cryogenic-Globe Valves with Pneumatic Actuator, PN50

air pressure for operation 6,0 bar g (maximum 10.0 bar g)

Stainless steel body and topwork,

Actuator - air opens, spring closes

"live loaded" gland packing

"cleaned and degreased for oxygen service" - the actuator is not cleaned and degreased for oxygen

Part No. 01353.X.T0**

* Butt weld connection for stainless steel pipes acc. to ISO 1127 or ASTM A312

Part No. 01353.X.T0*4

Socket weld connection for stainless steel pipes acc. to ISO 1127 or ASTM A312

Available options - on request only:

· Welded stainless steel stubs acc. to ISO 1127 or ASTM A312 - length FF + 200mm

Applications:

Approved for air gases, vapours and cryogenic liquefied gases incl. LNG.

Working temperature: -196°C / -321°F (77K) up to +120°C / +248°F (393K)



Materials	DIN EN	ASTM
1 Body	1.4308	A 351 CF8
2 Valve seal up to DN50	PTFE / Carbon filled (25%)	
2a Valve seal from DN65	PTFE	
3 Disc	1.4301	A 276 Grade 304
4 Bonnet gasket	PTFE	
5 Headpiece	1.4301	A 276 Grade 304
6 Bolts	1.4301/A2	A 194 B8
7 Elongation tube	1.4306	A 312 TP 304L
8 Stem	1.4301	A 276 Grade 304
9 Spring	1.4571	A 313 Grade 316Ti
10 Flange	1.4301	A 276 Grade 304
11 Headpiece	1.4301	A 276 Grade 304
12 Gland packing	Graphite / PTFE	
13 Gland nut	1.4571	A 276 Grade 316Ti
14 Pillars	1.4301	A 276 Grade 304
15 Bush	CW452K	B 159 UNS C51900
16 Actuator	Rubber	

Standard marking acc. to Pressure Equipment Directive 97/23/EC (PED).

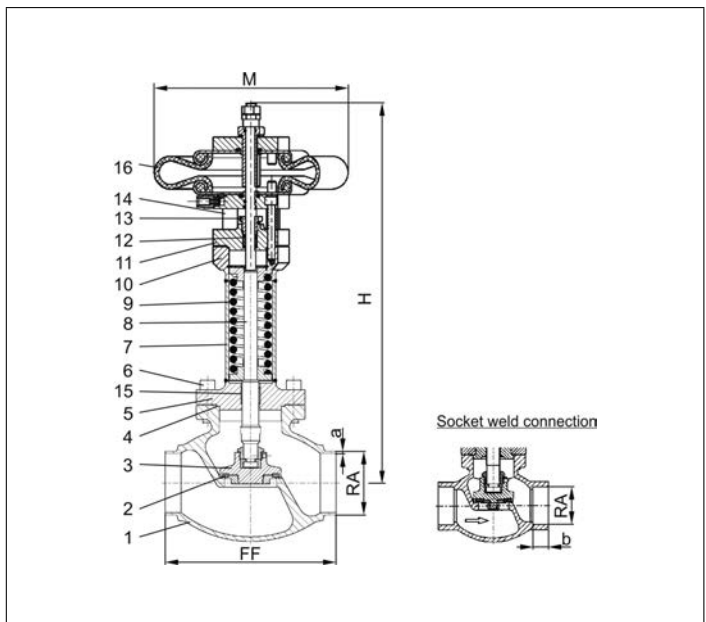

Type 01353	Technical data							
Nominal size	DN	15	25	40	40	50	65	80
Dimension code	.X.	1521	2533	4042	4048	5060	657x	8088
Face-to-face dimension	FF	85	115	130	130	155	205	245
Height	H	395	444	400	400	440	470	500
Outside pipe-Ø ISO 1127	RA	21.3	33.7	42.4	48.3	60.3	76.1	88.9
Wall thickness pipe ISO 1127	a	2.0	2.0	2.0	2.0	2.0	2.6	3.2
Outside pipe-Ø ASTM A312	RA	21.34	33.40	42.16	48.26	60.33	73.03	88.90
Wall thickness pipe ASTM A312	a	dimensions acc. to S10 or S40						
Socket depth	b	10	13	13	13	16	16	16
Actuator-Ø	M	229	229	229	229	229	229	229
Weight	ca. kg	7.2	9.1	10.5	10.5	14.5	17.4	22.5
Kvs-Value	m ³ /h	4.3	11.5	22.6	22.6	37.1	71.1	104.0
Cv-Value	gal/min	5.0	13.4	23.9	26.3	43.2	82.7	120.9
Stroke	mm	10	9	11	11	15	23	23
Δ P max	bar	50	50	31	16	16	10	4

Dimensions in mm.

Actuated Valves

Type 09343 - Actuated Gate Valve



Cryogenic-Gate Valves with Pneumatic Actuator, PN50

air pressure for operation 4.0 bar g (maximal 10.0 bar g),
 Stainless steel body and topwork,
 Actuator - air opens, spring closes
 one way tightening (in flow direction),
 "live loaded" gland packing
 "cleaned and degreased for oxygen service" - the actuator is not cleaned and degreased for oxygen

Part No. 09343.X.T02*

* Butt weld connection for stainless steel pipes acc. to ISO 1127 or ASTM A312

Part No. 09343.X.T024

Socket weld connection for stainless steel pipes acc. to ISO 1127 or ASTM A312

Available options - on request only:

- other connections are in preparation

Applications:

Approved for air gases, vapours and cryogenic liquefied gases incl. LNG.

Working temperature: -196°C / -321°F (77K) up to +120°C / +248°F (393K)



Materials	DIN EN	ASTM
1 Body	1.4308	A 351 CF8
2 Valve seal	PTFE / Carbon filled (25%)	
3 Disc	CW452K	B 159 UNS C51900
4 Wedge	1.4308	A 351 CF8
5 Stem	1.4301	A 276 Grade 304
6 Bonnet gasket	PTFE	
7 Headpiece	1.4308	A 351 CF8
8 Bolts	1.4301/A2	A 194 B8
9 Elongation tube	1.4541	A 213 TP 321
10 Spring	1.4571	A 313 Grade 316Ti
11 Flange	1.4301	A 276 Grade 304
12 Headpiece	1.4301	A 276 Grade 304
13 Gland packing	Graphite / PTFE	
14 Gland nut	1.4305	A 276 Grade 303
15 Pillars	1.4301	A 276 Grade 304
16 Bush	CW452K	B 159 UNS C51900
17 Actuator	Rubberchuk	

Standard marking acc. to Pressure Equipment Directive 97/23/EC (PED).

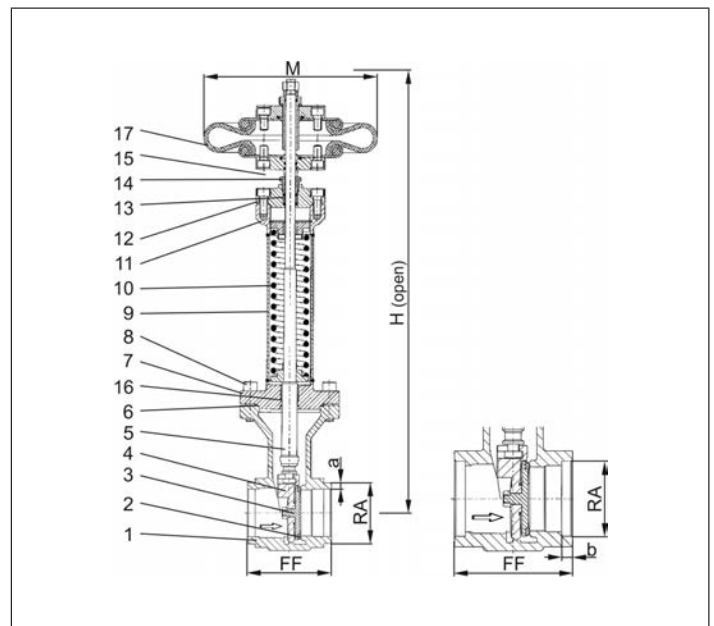

Type 09343 - Standard design	Technical data						
	DN	25	40	50	65	80	100
Nominal size	.X.	2533	4048	5060	657x	8088	0114
Dimension code	.X.	2533	4048	5060	657x	8088	0114
Face-to-face dimension	FF	133	133	110	110	110	130
Height	H	500	560	590	630	650	880
Outside pipe-Ø ISO 1127	RA	33.7	48.3	60.3	76.1	88.9	114.3
Wall thickness pipe ISO 1127	a	2.6	2.0	2.0	2.6	3.2	3.2
Outside pipe-Ø ASTM A312	RA	33.4	48.26	60.33	73.03	88.90	114.30
Wall thickness pipe ASTM A312	a	dimensions acc. to S10 or S40					
Socket depth	b	8	13	16	16	16	20
Actuator-Ø	M	229	229	229	229	229	229
Weight	ca. kg	9.9	11.1	13.5	14.9	17.5	30.2
Kvs-Value	m ³ /h	43	93	125	283	310	792
Cv-Value	gal/min	51	111	149	337	369	943

Dimensions in mm.

Actuated Valves

Type 09443 - Actuated Gate Valve



Cryogenic-Gate Valves with Pneumatic Actuator, PN50

air pressure for operation 4.0 bar g (maximal 10.0 bar g),
 Stainless steel body and topwork,
 Actuator - air opens, spring closes
 one way tightening (in flow direction),
 "live loaded" gland packing
 "cleaned and degreased for oxygen service" - the actuator is not cleaned and degreased for oxygen

Part No. 09443.X.T021

Male thread for union connection

Available options - on request only:

- other connections are in preparation



Applications:

Approved for air gases, vapours and cryogenic liquefied gases incl. LNG.
 Working temperature: -196°C / -321°F (77K) up to +120°C / +248°F (393K)

Materials	DIN EN	ASTM
1 Body	1.4308	A 351 CF8
2 Valve seal	PTFE / Carbon filled (25%)	
3 Disc	CW452K	B 159 UNS C51900
4 Wedge	1.4308	A 351 CF8
5 Stem	1.4301	A 276 Grade 304
6 Bonnet gasket	PTFE	
7 Headpiece	1.4301	A 276 Grade 304
8 Bolts	1.4301/A2	A 194 B8
9 Elongation tube	1.4541	A 213 TP 321
10 Spring	1.4571	A 313 Grade 316Ti
11 Flange	1.4301	A 276 Grade 304
12 Headpiece	1.4301	A 276 Grade 304
13 Gland packing	Graphite / PTFE	
14 Gland nut	1.4305	A 276 Grade 303
15 Pillars	1.4301	A 276 Grade 304
16 Bush	CW452K	B 159 UNS C51900
17 Actuator	Rubberchuk	

Standard marking acc. to Pressure Equipment Directive 97/23/EC (PED).

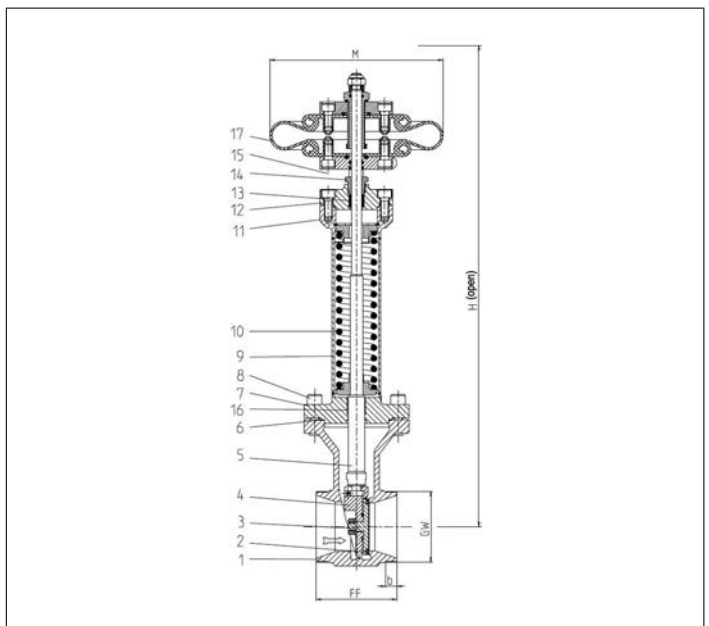

Type 09443 - Standard design	Technical data				
Nominal size	DN	25	40	50	65
Dimension code	.X.	0250	0400	0500	0650
Thread	GW	1	1-1/2	2	2-1/2
Face-to-face dimension	FF	133	133	110	110
Height	H	500	560	590	630
Thread type (G- / M-thread)	b	- / M40x2	G2 / M65x2	G2-1/2 / M78x2	G3 / M88x2
Actuator-Ø	M	229	229	229	229
Weight	ca. kg	9.9	11.1	13.5	14.9
Kvs-Value	m ³ /h	43	93	125	283
Cv-Value	gal/min	51	111	149	337

Dimensions in mm. * o.r.= on request



Accessories Actuated Valves

Type 40060 - Solenoid Valve



3/2 way Solenoid Valve

direct acting solenoid valve DN3, fast acting, body in brass, protecting class IP65, with cable plug for cable-Ø7 mm, circuit function: power free - outlet balanced, Pressure range 0 - 10.0 bar, Voltage tolerance ±10%, with flat seal and fixing screw

Port connection 1/4" G (BSP) thread: X= 0

Port connection 1/4" NPT thread: X= 6

Version with NBR sealing

for neutral medium like air and water

Medium temperature: 0°C / 32°F up to +80°C / 176°F

Ambient temperature: 0°C / 32°F up to max. +55°C / 131°F

Part No. 40060.020X.C24A000 - Operating voltage 24V, AC (50Hz)

Part No. 40060.020X.C11A000 - Operating voltage 110V, AC (50Hz)

Part No. 40060.020X.C23A000 - Operating voltage 230V, AC (50Hz)

Part No. 40060.020X.C24D000 - Operating voltage 24V, DC

Part No. 40060.020X.C48D000 - Operating voltage 48V, DC

Version with EPDM sealing

for oil and fat-free media

Medium temperature: -30°C / -22°F up to +90°C / 194°F

Ambient temperature: -30°C / -22°F up to max. +55°C / 131°F

Part No. 40060.020X.C24A00E - Operating voltage 230V, AC (50Hz)

Part No. 40060.020X.C11A00E - Operating voltage 110V, AC (50Hz)

Part No. 40060.020X.C23A00E - Operating voltage 230V, AC (50Hz)

Part No. 40060.020X.C24D00E - Operating voltage 24V, DC

Part No. 40060.020X.C48D00E - Operating voltage 48V, DC

Version with FKM sealing

for neutral medium like air and water

Medium temperature: 0°C / 32°F up to +90°C / 194°F

Ambient temperature: 0°C / 32°F up to max. +55°C / 131°F

Part No. 40060.020X.C24A0AF - Operating voltage 230V, AC (50Hz)

Part No. 40060.020X.C11A0AF - Operating voltage 110V, AC (50Hz)

Part No. 40060.020X.C23A0AF - Operating voltage 230V, AC (50Hz)

Part No. 40060.020X.C24D0AF - Operating voltage 24V, DC

Part No. 40060.020X.C48D0AF - Operating voltage 48V, DC

Version with FKM sealing, cleaned and degreased, suitable for oxygen

Part No. 40060.020X.C24AO2F - Operating voltage 230V, AC (50Hz)

Part No. 40060.020X.C11AO2F - Operating voltage 110V, AC (50Hz)

Part No. 40060.020X.C23AO2F - Operating voltage 230V, AC (50Hz)

Part No. 40060.020X.C24DO2F - Operating voltage 24V, DC

Part No. 40060.020X.C48DO2F - Operating voltage 48V, DC

Available options - on request only:

- other port connection (G1/8), body and seat material 1.4401
- circuit functions: power free - outlet pressure loaded

Standard
version



Accessories Actuated Valves

Type 41060 - Solenoid Valve



3/2 way Solenoid Valve, including fixing accessories

direct acting solenoid valve DN3, fast acting, body in brass, protecting class IP65, with cable plug for cable-Ø7 mm, circuit function: power free - outlet balanced, Pressure range 0 - 10.0 bar, Voltage tolerance $\pm 10\%$, with flat seal and fixing screw

Version with NBR sealing

port connections G (BSPP) 1/4 female thread, for neutral medium like air and water
Medium temperature: 0°C / 32°F up to +80°C / 176°F
Ambient temperature: 0°C / 32°F up to max. +55°C / 131°F

for actuators type 27511 and 27521

- Part No. 41060.0200.C24A000** - Operating voltage 24V, AC (50Hz)
- Part No. 41060.0200.C11A000** - Operating voltage 110V, AC (50Hz)
- Part No. 41060.0200.C23A000** - Operating voltage 230V, AC (50Hz)
- Part No. 41060.0200.C24D000** - Operating voltage 24V, DC
- Part No. 41060.0200.C48D000** - Operating voltage 48V, DC

for actuators type 27512 and 27522

- Part No. 41060.0210.C24A000** - Operating voltage 24V, AC (50Hz)
- Part No. 41060.0210.C11A000** - Operating voltage 110V, AC (50Hz)
- Part No. 41060.0210.C23A000** - Operating voltage 230V, AC (50Hz)
- Part No. 41060.0210.C24D000** - Operating voltage 24V, DC
- Part No. 41060.0210.C48D000** - Operating voltage 48V, DC

for actuators type 27514

- Part No. 41060.0220.C24A000** - Operating voltage 24V, AC (50Hz)
- Part No. 41060.0220.C11A000** - Operating voltage 110V, AC (50Hz)
- Part No. 41060.0220.C23A000** - Operating voltage 230V, AC (50Hz)
- Part No. 41060.0220.C24D000** - Operating voltage 24V, DC
- Part No. 41060.0220.C48D000** - Operating voltage 48V, DC

for actuators type 27515

- Part No. 41060.0230.C24A000** - Operating voltage 24V, AC (50Hz)
- Part No. 41060.0230.C11A000** - Operating voltage 110V, AC (50Hz)
- Part No. 41060.0230.C23A000** - Operating voltage 230V, AC (50Hz)
- Part No. 41060.0230.C24D000** - Operating voltage 24V, DC
- Part No. 41060.0230.C48D000** - Operating voltage 48V, DC

Version with EPDM sealing

port connections G (BSPP) 1/4 female thread, for oil- / degrease-free medium
Medium temperature: -30°C / -22°F up to +90°C / 194°F
Ambient temperature: -30°C / -22°F up to max. +55°C / 131°F

for actuators type 27511 and 27521

- Part No. 41060.0200.C23A00E** - Operating voltage 230V, AC (50Hz)
- Part No. 41060.0200.C24D00E** - Operating voltage 24V, DC

for actuators type 27512 and 27522

- Part No. 41060.0210.C23A00E** - Operating voltage 230V, AC (50Hz)
- Part No. 41060.0210.C24D00E** - Operating voltage 24V, DC

for actuators type 27514

- Part No. 41060.0220.C23A00E** - Operating voltage 230V, AC (50Hz)
- Part No. 41060.0220.C24D00E** - Operating voltage 24V, DC

for actuators type 27515

- Part No. 41060.0230.C23A00E** - Operating voltage 230V, AC (50Hz)
- Part No. 41060.0230.C24D00E** - Operating voltage 24V, DC

Available options - on request only:

- other port connections (1/4"NPT, G1/8), body and seat material 1.4401
- circuit functions: power free - outlet pressure loaded

Standard version



Accessories Actuated Valves

Type 40061 - Solenoid Valve EEx



3/2 way Solenoid Valve, EEx-protected

direct acting solenoid valve DN3, fast acting, body in brass, protecting class IP65 EEx ed IIC T5, with cable 3 x 0,75 mm², circuit function: power free - outlet balanced, Pressure range 0 - 10.0 bar, Voltage tolerance $\pm 10\%$, semi time-lag fuse acc. to nominal voltage

UC = universal current (universal control voltage)

Port connection 1/4" G (BSPP) thread: X= 0

Port connection 1/4" NPT thread: X= 6

Version with NBR sealing

port connections G (BSPP) 1/4 female thread, for neutral medium like air and water

Medium temperature: 0°C / 32°F up to +70°C / 158°F

Ambient temperature: 0°C / 32°F up to max. +55°C / 131°F

Part No. 40061.020X.C024030 - Operating voltage 24V, UC, with 3 meter cable

Part No. 40061.020X.C024050 - Operating voltage 24V, UC, with 5 meter cable

Part No. 40061.020X.C230030 - Operating voltage 230V, UC, with 3 meter cable

Part No. 40061.020X.C230050 - Operating voltage 230V, UC, with 5 meter cable

Part No. 40061.020X.C11A030 - Operating voltage 110V, AC (50 Hz), with 3 meter cable

Part No. 40061.020X.C11A050 - Operating voltage 110V, AC (50 Hz), with 5 meter cable

EEx-protected
version



Available options - on request only:

- other port connections (G1/8), body and seat material 1.4401
- circuit functions: power free - outlet pressure loaded

Accessories Actuated Valves

Type 41061 - Solenoid Valve EEx



3/2 way Solenoid Valve, EEx-protected, including fixing accessories

direct acting solenoid valve DN3, fast acting, body in brass, protecting class IP65 EEx ed IIC T5, with cable 3 x 0,75 mm² - cable 3 meter long, circuit function: power free - outlet balanced, Pressure range 0 - 10.0 bar, Voltage tolerance ±10%, semi time-lag fuse acc. to nominal voltage

Version with NBR sealing

port connections G (BSPP) 1/4 female thread, for neutral medium like air and water

Medium temperature: 0°C / 32°F up to +70°C / 158°F

Ambient temperature: 0°C / 32°F up to max. +55°C / 131°F

for actuators type 27511 and 27521

Part No. 41061.0200.C024030 - Operating voltage 24V, UC, with 3 meter cable

Part No. 41061.0200.C230030 - Operating voltage 230V, UC, with 3 meter cable

for actuators type 27512 and 27522

Part No. 41061.0210.C024030 - Operating voltage 24V, UC, with 3 meter cable

Part No. 41061.0210.C230030 - Operating voltage 230V, UC, with 3 meter cable

for actuators type 27514

Part No. 41061.0220.C024030 - Operating voltage 24V, UC, with 3 meter cable

Part No. 41061.0220.C230030 - Operating voltage 230V, UC, with 3 meter cable

for actuators type 27515

Part No. 41061.0230.C024030 - Operating voltage 24V, UC, with 3 meter cable

Part No. 41061.0230.C230030 - Operating voltage 230V, UC, with 3 meter cable

port connections 1/4" NPT female thread, for neutral medium like air and water

Medium temperature: 0°C / 32°F up to +70°C / 158°F

Ambient temperature: 0°C / 32°F up to max. +55°C / 131°F

for actuators type 27511 and 27521

Part No. 41061.0206.C024030 - Operating voltage 24V, UC, with 3 meter cable

Part No. 41061.0206.C024050 - Operating voltage 24V, UC, with 5 meter cable

Part No. 41061.0206.C11A030 - Operating voltage 110V, AC (50 Hz), with 3 meter cable

Part No. 41061.0206.C11A050 - Operating voltage 110V, AC (50 Hz), with 5 meter cable

for actuators type 27512 and 27522

Part No. 41061.0216.C024030 - Operating voltage 24V, UC, with 3 meter cable

Part No. 41061.0216.C024050 - Operating voltage 24V, UC, with 5 meter cable

Part No. 41061.0216.C11A030 - Operating voltage 110V, AC (50 Hz), with 3 meter cable

Part No. 41061.0216.C11A050 - Operating voltage 110V, AC (50 Hz), with 5 meter cable

for actuators type 27514

Part No. 41061.0226.C024030 - Operating voltage 24V, UC, with 3 meter cable

Part No. 41061.0226.C024050 - Operating voltage 24V, UC, with 5 meter cable

Part No. 41061.0226.C11A030 - Operating voltage 110V, AC (50 Hz), with 3 meter cable

Part No. 41061.0226.C11A050 - Operating voltage 110V, AC (50 Hz), with 5 meter cable

for actuators type 27515

Part No. 41061.0236.C024030 - Operating voltage 24V, UC, with 3 meter cable

Part No. 41061.0236.C024050 - Operating voltage 24V, UC, with 5 meter cable

Part No. 41061.0236.C11A030 - Operating voltage 110V, AC (50 Hz), with 3 meter cable

Part No. 41061.0236.C11A050 - Operating voltage 110V, AC (50 Hz), with 5 meter cable

UC = DC and AC

Available options - on request only:

- other port connections (G1/8), body and seat material 1.4401
- circuit functions: power free - outlet pressure loaded

EEx-protected version



Accessories Actuated Valves

Type 41060 - Solenoid Valve, suitable for oxygen



3/2 way Solenoid Valve, including fixing accessories

direct acting solenoid valve DN3, fast acting, body in brass, protecting class IP65, with cable plug for cable-Ø7 mm, circuit function: power free - outlet balanced, Pressure range 0 - 10.0 bar, Voltage tolerance $\pm 10\%$, with flat seal and fixing screw

Version with FKM sealing, cleaned and degreased, suitable for oxygen

port connections G (BSPP) 1/4 female thread, for neutral medium like air and water
Medium temperature: 0°C / 32°F up to +90°C / 194°F
Ambient temperature: 0°C / 32°F up to max. +55°C / 131°F

for actuators type 27511 and 27521

Part No. 41060.0200.C24AO2F - Operating voltage 24V, AC (50Hz)

Part No. 41060.0200.C23AO2F - Operating voltage 230V, AC (50Hz)

for actuators type 27512 and 27522

Part No. 41060.0210.C24AO2F - Operating voltage 24V, AC (50Hz)

Part No. 41060.0210.C23AO2F - Operating voltage 230V, AC (50Hz)

for actuators type 27514

Part No. 41060.0220.C24AO2F - Operating voltage 24V, AC (50Hz)

Part No. 41060.0220.C23AO2F - Operating voltage 230V, AC (50Hz)

for actuators type 27515

Part No. 41060.0230.C24AO2F - Operating voltage 24V, AC (50Hz)

Part No. 41060.0230.C23AO2F - Operating voltage 230V, AC (50Hz)

Available options - on request only:

- other port connections (1/4"NPT, G1/8)
- circuit functions: power free - outlet pressure loaded

Standard
version



Accessories Actuated Valves

Type 40070, Type 40071 - Position and Limit Switches



Position and Limit Switches

Limit switch (0/100%) with parallel roller lever and fixing device, quick-break switch,
Max. fuse rating 6A gL/gD D-fuse, Switching frequency 3600/h

Standard version

Protection class IP65 acc. to EN 60529,
Rated operating current/-voltage Ie/Ue: 6A / 400VAC,
3 cable entries M16 x 1.5,
change-over contact with double break (1 break contact/ 1 make contact),
Ambient temperature -20°C / -4°F up to +80°C / 176°F

Part No. 40070.0011.0100100

Standard version



Position and Limit Switches

Limit switch (0/100%) with parallel roller lever and fixing device, quick-break switch,
Max. fuse rating 5A gG/gN-fuse, Switching frequency 1800/h

EEx-protected version

Protection class IP65 acc. to EN 60529, EEX d IIC T6,
Rated operating current/-voltage Ie/Ue: 5A / 250VAC,
with cable 4 x 0,75 mm²
change-over contact with single break (1 break contact/ 1 make contact),
Ambient temperature -20°C / -4°F up to +60°C / 140°F

Part No. 40071.0012.1322000 - with 3 meter cable

Part No. 40071.0012.1325000 - with 10 meter cable

EEx-protected version



Available options - on request only:

- overrun limit switch to signal intermediate positions
- other cable length

Accessories Actuated Valves

Type 41070, Type 41071 - Position and Limit Switches



Position and Limit Switches, including fixing device

Limit switch (0/100%) with parallel roller lever and fixing device, quick-break switch,
Max. fuse rating 6A gL/gD D-fuse, Switching frequency 3600/h

Standard version

for actuators type 27511, 27512, 27521 and 27522

Part No. 41070.0011.0100100

Protection class IP65 acc. to EN 60529,
Rated operating current/-voltage Ie/Ue: 6A / 400VAC,
3 cable entries M16 x 1.5,
change-over contact with double break (1 break contact/ 1 make contact),
Ambient temperature -20°C / -4°F up to +80°C / 176°F

for actuators type 27514 and 27515

Part No. 41370.0011.0100100

Protection class IP65 acc. to EN 60529,
Rated operating current/-voltage Ie/Ue: 6A / 400VAC,
3 cable entries M16 x 1.5,
change-over contact with double break (1 break contact/ 1 make contact),
Ambient temperature -20°C / -4°F up to +80°C / 176°F

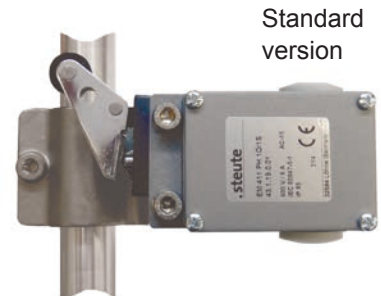

Standard version

Position and Limit Switches

Limit switch (0/100%) with parallel roller lever and fixing device, quick-break switch,
Max. fuse rating 5A gG/gN-fuse, Switching frequency 1800/h

EEx-protected version

for actuators type 27511, 27512, 27521 and 27522

Part No. 41071.0012.1322000

Protection class IP65 acc. to EN 60529, EEX d IIC T6,
Rated operating current/-voltage Ie/Ue: 5A / 250VAC,
with cable 4 x 0,75 mm² - cable 3 meter long,
change-over contact with single break (1 break contact/ 1 make contact),
Ambient temperature -20°C / -4°F up to +60°C / 140°F

for actuators type 27514 and 27515

Part No. 41371.0012.1322000

Protection class IP65 acc. to EN 60529, EEX d IIC T6,
Rated operating current/-voltage Ie/Ue: 5A / 250VAC,
with cable 4 x 0,75 mm² - cable 3 meter long,
change-over contact with single break (1 break contact/ 1 make contact),
Ambient temperature -20°C / -4°F up to +60°C / 140°F



EEx-protected version

Available options - on request only:

- overrun limit switch to signal intermediate positions
- other cable length

Accessories Actuated Valves

Type 40080 - Inductive Proximity Switches



Inductive proximity switches

Functions: inductive, Switching element function NAMUR NC, Output polarity NAMUR,
Rated operating distance 2 mm, Assured operating distance 0 - 1.62 mm, Installation embeddable,
Nominal voltage 8.2V, Switch frequency 0 - 1000 Hz, Short-circuit and reverse polarity protection,
Protecting class IP66/ IP67 acc. to EN 60529, EEX ia IIC T6
Indication of the switching state all direction LED yellow, with cable 2m x 0.34 mm²
Ambient temperature: -25°C / -13°F up to +70°C / 158°F

Part No. 40080.1235.0A20100 - with 2 meter cable

Part No. 40080.1235.0A20400 - with 10 meter cable

Part No. 40080.1235.0A20700 - with 25 meter cable



Functions: inductive, Switching element function PNP closer, Output polarity DC,
Rated operating distance 2 mm, Assured operating distance 0 - 1.62 mm, Installation embeddable,
Nominal voltage 10 - 60V, Switch frequency 0 - 3000 Hz, Short-circuit and reverse polarity protection,
Protecting class IP66/ IP67 acc. to EN 60529
Indication of the switching state all direction LED yellow, with appliance inlet M12 x 1 - 4 pole
Ambient temperature: -25°C / -13°F up to +70°C / 158°F

Part No. 40080.1240.0B10100 - with 2 meter cable

Induktive sensor: NCB2-12GM40-Z0

Functions: inductive, Switching element function DC closer, Output polarity DC,
Rated operating distance 2 mm, Assured operating distance 0 - 1.62 mm, Installation embeddable,
Nominal voltage 5 - 60V, Switch frequency 0 - 800 Hz, Short-circuit clocking,
Protecting class IP66/ IP67 acc. to EN 60529
Indication of the switching state all direction LED yellow, with cable 2m x 0.14 mm²
Ambient temperature: -25°C / -13°F up to +70°C / 158°F

Part No. 40080.1240.0C10100 - with 2 meter cable

Available options - on request only:

- other cable length

Accessories Actuated Valves

Type 41080 - Inductive Proximity Switches



Inductive proximity switches, including fixing device

Functions: inductive, Switching element function NAMUR NC, Output polarity NAMUR, Rated operating distance 2 mm, Assured operating distance 0 - 1.62 mm, Installation embeddable, Nominal voltage 8.2V, Switch frequency 0 - 1000 Hz, Short-circuit and reverse polarity protection, Protecting class IP66/ IP67 acc. to EN 60529, EEX ia IIC T6

Indication of the switching state all direction LED yellow, with cable 2m x 0.34 mm²

Ambient temperature: -25°C / -13°F up to +70°C / 158°F

for actuators type 27511, 27512, 27521 and 27522

Part No. 41080.1235.AA20100 (Valve size DN10 - DN150), with 2 meter cable

Part No. 41080.1235.AA20400 (Valve size DN10 - DN150), with 10 meter cable

for actuators type 27514 and 27515

Part No. 41080.1235.BA20100 (Valve size DN10 - DN50), with 2 meter cable

Part No. 41080.1235.BA20400 (Valve size DN10 - DN50), with 10 meter cable

Part No. 41080.1235.CA20100 (Valve size DN65), with 2 meter cable

Part No. 41080.1235.CA20400 (Valve size DN65), with 10 meter cable

Part No. 41080.1235.DA20100 (Valve size DN80 - DN100), with 2 meter cable

Part No. 41080.1235.DA20400 (Valve size DN80 - DN100), with 10 meter cable

Part No. 41080.1235.EA20100 (Valve size DN150), with 2 meter cable

Part No. 41080.1235.EA20400 (Valve size DN150), with 10 meter cable

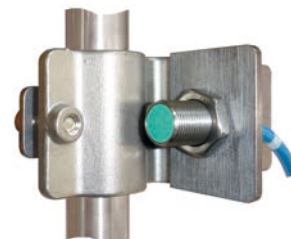

Functions: inductive, Switching element function PNP closer, Output polarity DC, Rated operating distance 2 mm, Assured operating distance 0 - 1.62 mm, Installation embeddable, Nominal voltage 10 - 60V, Switch frequency 0 - 3000 Hz, Short-circuit and reverse polarity protection, Protecting class IP66/ IP67 acc. to EN 60529

Indication of the switching state all direction LED yellow, with appliance inlet M12 x 1 - 4 pole

Ambient temperature: -25°C / -13°F up to +70°C / 158°F

for actuators type 27511, 27512, 27521 and 27522

Part No. 41080.1240.AB10100 (Valve size DN10 - DN150)

for actuators type 27514 and 27515

Part No. 41080.1240.BB10100 (Valve size DN10 - DN50)

Part No. 41080.1240.CB10100 (Valve size DN65)

Part No. 41080.1240.DB10100 (Valve size DN80 - DN100)

Part No. 41080.1240.EB10100 (Valve size DN150)

Induktive sensor: NCB2-12GM40-Z0

Functions: inductive, Switching element function DC closer, Output polarity DC, Rated operating distance 2 mm, Assured operating distance 0 - 1.62 mm, Installation embeddable, Nominal voltage 5 - 60V, Switch frequency 0 - 800 Hz, Short-circuit clocking, Protecting class IP66/ IP67 acc. to EN 60529

Indication of the switching state all direction LED yellow, with cable 2m x 0.14 mm² - 2 meter long

Ambient temperature: -25°C / -13°F up to +70°C / 158°F

for actuators type 27511, 27512, 27521 and 27522

Part No. 41080.1240.AC10100 (Valve size DN10 - DN150)

for actuators type 27514 and 27515

Part No. 41080.1240.BC10100 (Valve size DN10 - DN50)

Part No. 41080.1240.CC10100 (Valve size DN65)

Part No. 41080.1240.DC10100 (Valve size DN80 - DN100)

Part No. 41080.1240.EC10100 (Valve size DN150)

Available options - on request only:

- other cable length

Accessories Actuated Valves

Type 08002 - Air Control Sets



Air Control sets

Diaphragm pressure regulator with secondary ventilation,
 Installation position vertical - drain plug at bottom,
 Inlet pressure maximal 16.0 bar,
 filter element in Polyethylen (sintered), pore diameter in filter element 5µm,
 port connections G1/4, body zinc-diecasting, with NBR seal,
 tank capacity maximal 0.35 cm³ condensate, condensate draining manuel,
 Ambient temperature: -10°C / 14°F up to +60°C / 140°F,
 including pressure gauge (0 - 10.0 bar)

Part No. 08002.021K.0000

condensate tank Polycarbonat, control range 0.5 - 10.0 bar



Part No. 08002.021M.0000

condensate tank in metal, control range 0,5 - 16.0 bar



Adapter 1/4" NPT female thread - G1/4 male thread

Part No. 29001.0004.0302

material brass (CW614N / ASTM B 283 UNS C38500)

Part No. 29001.0004.0783

material stainless steel (1.4404 / ASTM 316L))

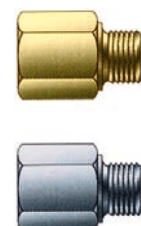
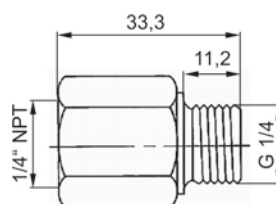

Accessories Actuated Valves

Type 08003 - Air Control Sets



Air Control sets, including fixing accessories

Diaphragm pressure regulator with secondary ventilation,
Installation position vertical - drain plug at bottom,
Inlet pressure maximal 16.0 bar,
filter element in Polyethylen (sinterted), pore diameter in filter element 5µm,
port connections G1/4, body zinc-diecasting, with NBR seal,
tank capacity maximal 0.35 cm³ condensate, condensate draining manuel,
Ambient temperature: -10°C / 14°F up to +60°C / 140°F,
including pressure gauge (0 - 10.0 bar)

Part No. 08003.021K.0000

condensate tank Polycarbonat, control range 0.5 - 10.0 bar

Part No. 08003.021M.0000

condensate tank in metal, control range 0,5 - 16.0 bar



Air Control sets in stainless steel, including fixing accessories

Installation position vertical - drain plug at bottom,
Inlet pressure maximal 20.0 bar, control range 0.5 - 10.0 bar
filter element in stainless steel (1.4408 / ASTM 316), pore diameter in filter element 40µm,
body in stainless steel (1.4408 / ASTM 316), with NBR seal,
condensate draining manuel,
Medium temperature: -50°C / 58°F up to +90°C / 194°F,
Ambient temperature: -50°C / 58°F up to +90°C / 194°F,
including pressure gauge (0 - 10.0 bar)

Part No. 08003.0200.0000

port connections G1/4 female thread

Part No. 08003.0206.0000

port connections 1/4" NPT female thread



Adapter 1/4" NPT female thread - G1/4 male thread

Part No. 29001.0004.0302

material brass (CW614N / ASTM B 283 UNS C38500)

Part No. 29001.0004.0783

material stainless steel (1.4404 / ASTM 316L))

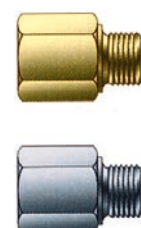
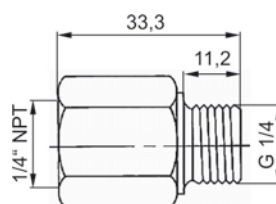

Accessories Actuated Valves

Type 40090 - Electropneumatic Positioner



Electropneumatic positioner for pneumatic Actuator

ATTENTION - operate only with dry, oil-free air acc. to IEC654-2 !

Protecting class IP65 acc. to EN 60529,

Operation: simple, Inlet air pressure: max. 6.0 bar - connection with female thread G1/4

Electrical connection: screw type terminals 2.5 mm², cable gland: M 20 x 1.5

Set point x:

4 - 20 mA with 2 conductor connections

0/4 - 20 mA with 3/4 conductor connections

Auxiliary power with 3/4 conductor connections: UH: 18-30V DC

Internal resistance:

R_i = 500 Ohm (2-wire)

R_i = 50 Ohm (3/4-wire)

Ambient temperature: -30°C / -22°F up to +80°C / 176°F



Part No. 40090.6136.00DA000

standard version (3/4-wire)

Part No. 40090.6136.00DA010

with installed limit indicator, incl. 2nd cable fitting, alarm module; electronic (6DR4004-8A), (3/4-wire)

Part No. 40090.6136.00DA020

with LY-module: 4...20 mA check-back signal (3/4-wire)

Part No. 40090.6136.00EA000

with Profibus PA connection

Part No. 40090.6136.00FA000

with foundation fieldbus and fixable friction clutch

Part No. 40090.6136.00BA100

with HART connection (2-wire)



Accessories Actuated Valves

Type 41090 - Electropneumatic Positioner



Electropneumatic positioner for pneumatic Actuator

ATTENTION - operate only with dry, oil-free air acc. to IEC654-2 !

Protecting class IP65 acc. to EN 60529,

Operation: simple, Inlet air pressure: max. 6.0 bar - connection with female thread G1/4

Electrical connection: screw type terminals 2.5 mm², cable gland: M 20 x 1.5

Set point x:

4 - 20 mA with 2 conductor connections

0/4 - 20 mA with 3/4 conductor connections

Auxiliary power with 3/4 conductor connections: UH: 18-30V DC

Internal resistance:

R_i = 500 Ohm (2-wire)

R_i = 50 Ohm (3/4-wire)

Ambient temperature: -30°C / -22°F up to +80°C / 176°F

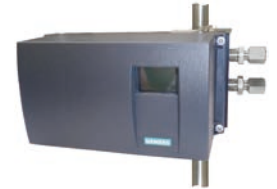

inclusive fixing device for actuators with lift up to 35.0 mm

for actuators type 27511, 27514 and 27521 (spring to close)

Part No. 41090.6136.00DA000

standard version (3/4-wire)

Part No. 41090.6136.00DA010

with installed limit indicator, incl. 2nd cable fitting, alarm module; electronic (6DR4004-8A), (3/4-wire)

Part No. 41090.6136.00DA020

with LY-module: 4...20 mA check-back signal (3/4-wire)

Part No. 41090.6136.00EA000

with Profibus PA connection

Part No. 41090.6136.00FA000

with foundation fieldbus and fixable friction clutch

Part No. 41090.6136.00BA100

with HART connection (2-wire)

for actuators type 27512, 27515 and 27522 (spring to open)

Part No. 41090.6136.01DA000

standard version (3/4-wire)

Part No. 41090.6136.01DA010

with installed limit indicator, incl. 2nd cable fitting, alarm module; electronic (6DR4004-8A), (3/4-wire)

Part No. 41090.6136.01DA020

with LY-module: 4...20 mA check-back signal (3/4-wire)

Part No. 41090.6136.01EA000

with Profibus PA connection

Part No. 41090.6136.01FA000

with foundation fieldbus and fixable friction clutch

Part No. 41090.6136.01BA100

with HART connection (2-wire)

inclusive fixing device for actuators with lift from 35.0 mm up to 130.0 mm

for actuators type Typ 27511, 27512, 27514, 27515, 27521 and 27522

Part No. 41090.6136.12DA000

standard version (3/4-wire)

Part No. 41090.6136.12DA010

with installed limit indicator, incl. 2nd cable fitting, alarm module; electronic (6DR4004-8A), (3/4-wire)

Part No. 41090.6136.12DA020

with LY-module: 4...20 mA check-back signal (3/4-wire)

Part No. 41090.6136.12EA000

with Profibus PA connection

Part No. 41090.6136.12FA000

with foundation fieldbus and fixable friction clutch

Part No. 41090.6136.12BA100

with HART connection (2-wire)

Accessories Actuated Valves

Type 40091 - Electropneumatic Positioner EEx



Electropneumatic positioner for pneumatic Actuator

ATTENTION - operate only with dry, oil-free air acc. to IEC654-2 !

Protecting class IP65 acc. to EN 60529, with EEx-protection: II 2 G EEx ia IIC T6

Operation: simple, Inlet air pressure: max. 6.0 bar - connection with female thread G1/4

Electrical connection: screw type terminals 2.5 mm², cable gland: M 20 x 1.5

Set point x:

4 - 20 mA with 2 conductor connections

Internal resistance:

R_i = 500 Ohm (2-wire)

Ambient temperature: -30°C / -22°F up to +50°C / 122°F

Part No. 40091.6136.00AA000

standard version - 2 wire connection

Part No. 40091.6136.00AA020

with LY-module: 4...20 mA check-back signal (2-wire)

Part No. 40091.6136.00EA000

with Profibus PA connection



Accessories Actuated Valves

Type 41091 - Electropneumatic Positioner EEx



Electropneumatic positioner for pneumatic Actuator

ATTENTION - operate only with dry, oil-free air acc. to IEC654-2 !

Protecting class IP65 acc. to EN 60529, with EEx-protection: II 2 G EEx ia IIC T6

Operation: simple, Inlet air pressure: max. 6.0 bar - connection with female thread G1/4

Electrical connection: screw type terminals 2.5 mm², cable gland: M 20 x 1.5

Set point x:

4 - 20 mA with 2 conductor connections

Internal resistance:

R_i = 500 Ohm (2-wire)

Ambient temperature: -30°C / -22°F up to +50°C / 122°F

inclusive fixing device for actuators with lift up to 35.0 mm

for actuators type 27511, 27514 and 27521 (spring to close)

Part No. 41091.6136.00AA000

standard version - 2 wire connection

Part No. 41091.6136.00AA020

with LY-module: 4...20 mA check-back signal (2-wire)

Part No. 41091.6136.00EA000

with Profibus PA connection

for actuators type 27512, 27515 and 27522 (Feder öffnet)

Part No. 41091.6136.01AA000

standard version - 2 wire connection

Part No. 41091.6136.01AA020

with LY-module: 4...20 mA check-back signal (2-wire)

Part No. 41091.6136.01EA000

with Profibus PA connection

inclusive fixing device for actuators with lift from 35.0 mm up to 130.0 mm

for actuators type 27511, 27512, 27514, 27515, 27521 and 27522

Part No. 41091.6136.12AA000

standard version - 2 wire connection

Part No. 41091.6136.12AA020

with LY-module: 4...20 mA check-back signal (2-wire)

Part No. 41091.6136.12EA000

with Profibus PA connection

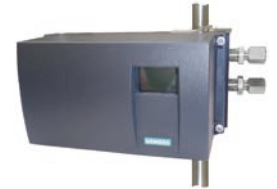

Accessories Actuated Valves

Type 40090 - Pneumatic Positioner

Pneumatic positioner for pneumatic Actuator

ATTENTION - operate only with dry, oil-free air acc. to IEC654-2 !
Protecting class IP54 acc. to EN 60529,

Part No. 40090.0981.00NB200

Operation: simple, Inlet air pressure: max. 6.0 bar
Independent adjustment of stroke range and zero,
Signal range 0.2 - 1.0 bar or split range down to Δw 0.2 bar,
adjustable amplification and damping,
Ambient temperature: -40°C / -40°F up to +80°C / 176°F

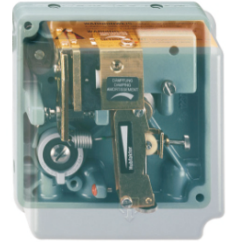

Accessories Actuated Valves

Type 41090 - Pneumatic Positioner

Pneumatic positioner for pneumatic Actuator, including fixing device

ATTENTION - operate only with dry, oil-free air acc. to IEC654-2 !

Protecting class IP54 acc. to EN 60529,

Part No. 41090.0981.22NB200

Operation: simple, Inlet air pressure: max. 6.0 bar - connection with female thread G1/8

Independent adjustment of stroke range and zero,

Signal range 0.2 - 1.0 bar or split range down to Δw 0.2 bar,

adjustable amplification and damping,

Ambient temperature: -40°C / -40°F up to +80°C / 176°F

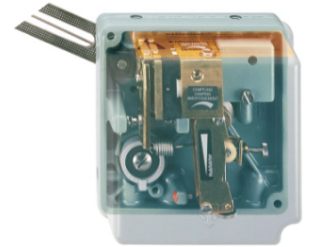

Accessories Actuated Valves

Type 40281 - Inductive Proximity Switches EEx-Box



Inductive Proximity Switches - EEx-protected

Functions: inductive, Switching element function NAMUR Opener, Output polarity NAMUR, Rated operating distance 5mm, Nominal voltage 8V DC, Switch frequency 0 - 3000Hz, until SIL2 acc. to IEC 61508 suitable, protecting class IP67 acc. to EN 60529, EEX ia IIC T6 Bracket, shaft and screws made of stainless steel SS316
Working temperature: -40°C / -40°F (233K) up to +80°C / +176°F (353K)
Dimensions (width x height x depth): 8 x 15 x 7 cm

Part No. 40281.1114.0A300A0

with cable gland M20, made of plastic, WAGO terminal block
with universal limit switch box ATEX EexialICT6 made of plastic IP67
with 2 x switches (P+F NJ5-11-NG)

Part No. 40281.1114.0A500A0

with 2 cable glands M20, made of plastic, WAGO terminal block
with universal limit switch box ATEX EexialICT6 made of plastic IP67
with 2 x switches (P+F NJ5-11-NG)

Special equipment with limit switch box made of aluminium

Part No. 40281.1114.0A400B0

with cable gland M20, made of brass, nickel plated, WAGO terminal block
with universal limit switch box ATEX EexialICT6 made of aluminium IP67
with 2 x switches (P+F NJ5-11-NG)

Part No. 40281.1114.0A600B0

with cable gland 1/2" NPT, made of plastic, WAGO terminal block
with universal limit switch box ATEX EexialICT6 made of aluminium IP67
with 2 x switches (P+F NJ5-11-NG)



Accessories Actuated Valves

Type 41281 - Inductive Proximity Switches EEx-Box



Inductive Proximity Switches - EEx-protected, including fixing device

Functions: inductive, Switching element function NAMUR Opener, Output polarity NAMUR, Rated operating distance 5mm, Nominal voltage 8V DC, Switch frequency 0 - 3000Hz, until SIL2 acc. to IEC 61508 suitable, protecting class IP67 acc. to EN 60529, EEX ia IIC T6
Bracket, shaft and screws made of stainless steel SS316
Working temperature: -40°C / -40°F (233K) up to +80°C / +176°F (353K)
Dimensions (width x height x depth): 8 x 15 x 7 cm (without bracket)

Part No. 41281.1114.FA300A0

with cable gland M20, made of plastic, WAGO terminal block
with universal limit switch box ATEX EexialICT6 made of plastic IP67
with 2 x switches (P+F NJ5-11-NG)
including bracket for pneumatic actuator DN10 - DN150

Part No. 41281.1114.FA500A0

with 2 cable glands M20, made of plastic, WAGO terminal block
with universal limit switch box ATEX EexialICT6 made of plastic IP67
with 2 x switches (P+F NJ5-11-NG)
including bracket for pneumatic actuator DN10 - DN150

Part No. 41281.1114.GA300A0

with cable gland M20, made of plastic, WAGO terminal block
with universal limit switch box ATEX EexialICT6 made of plastic IP67
with 2 x switches (P+F NJ5-11-NG)
including bracket for Firestone actuator (rubber bellow) for stroke up to 40mm

Special equipment with limit switch box made of aluminium

Part No. 41281.1114.FA400B0

with cable gland M20, made of brass, nickel plated, WAGO terminal block
with universal limit switch box ATEX EexialICT6 made of aluminium IP67
with 2 x switches (P+F NJ5-11-NG)
including bracket for pneumatic actuator DN10 - DN150

Part No. 41281.1114.FA600B0

with cable gland 1/2" NPT, made of plastic, WAGO terminal block
with universal limit switch box ATEX EexialICT6 made of aluminium IP67
with 2 x switches (P+F NJ5-11-NG)
including bracket for pneumatic actuator DN10 - DN150



Σ-D

Accessories Actuated Valves

Type 74394 - Bracket for accessories



Bracket for accessories
for Cryogenic-Gate Valves with Pneumatic Actuator

Part No. 74394.0005.0783
Stroke: 1.0 - 40.0mm
Globe valves until DN80
Gate valves until DN40

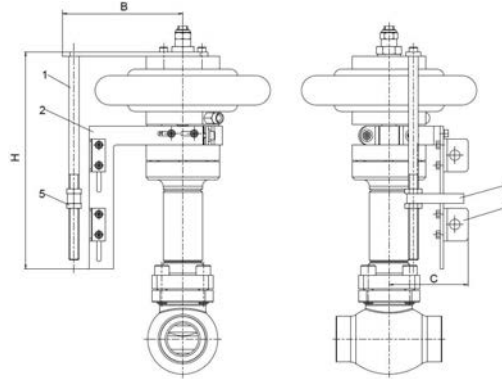

Part No. 74394.0008.0783
Stroke: 40.1 - 100.0mm
Globe valves from DN100
Gate valves from DN50

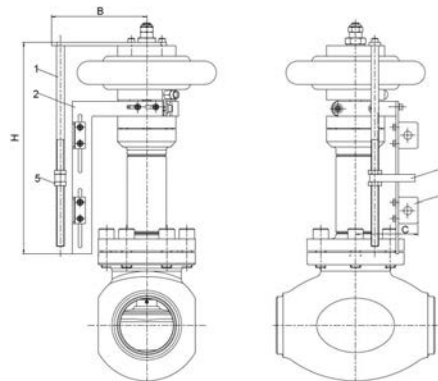

Materials	DIN EN	ASTM
1 Bracket	1.4404	
2 Angle	1.4404	B 159 UNS C51900
3 Stopper	1.4571	A 351 CF8
4 Bracket	1.4404	A 276 Grade 304
5 Nut	1.4571/A4	

For use with the following accessories:
 · Type 40070, 40071 - Position and Limit Switches
 · Type 40080 - Inductive Proximity Switches

Typ 74394		Technical Data	
Part Number		74394.0005.0783	74394.0008.0783
Length	B	147.5	147.5
Height	H	266	326
Length	C	96.7	96.7
Weight	ca. kg	1.2	1.3

Dimensions in mm.

Spare Parts Actuated Valves

Type 29343 - Topwork with pneumatic actuator



for Cryogenic-Gate Valves with Pneumatic Actuator

air pressure for operation 4,0 bar g (maximal 10,0 bar g),

Stainless steel topwork,

Actuator - air opens, spring closes

one way tightening (in flow direction),

"live loaded" gland packing

"cleaned and degreased for oxygen service" - the actuator is not cleaned and

degreased for oxygen

Part No. 29343.X.T020

suitable for:

Type	Nominal size
09343	DN25 - DN100
09443	DN25 - DN65



Materials	DIN EN	ASTM
1 Valve seal	PTFE / Carbon filled (25%)	
2 Disc	CW452K B 159 UNS C51900	
3 Wedge	1.4308	A 351 CF8
4 Stem	1.4301	A 276 Grade 304
5 Bonnet gasket	PTFE	
6 Headpiece	1.4308	A 351 CF8
7 Bolts	1.4301/A2	A 194 B8
8 Elongation tube	1.4541	A 213 TP 321
9 Spring	1.4571	A 313 Grade 316Ti
10 Flange	1.4301	A 276 Grade 304
11 Headpiece	1.4301	A 276 Grade 304
12 Gland packing	Graphite / PTFE	
13 Gland nut	1.4305	A 276 Grade 303
14 Pillars	1.4301	A 276 Grade 304
15 Bush	CW452K B 159 UNS C51900	
16 Actuator	Rubber	

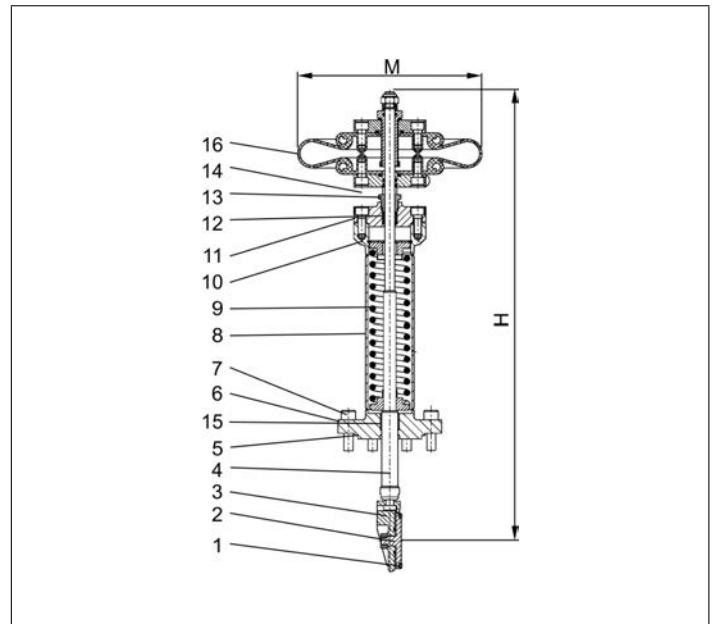

Type 29343.X.T020	Technical data						
Nominal size	DN	25	40	50	65	80	100
Dimension code	.X.	0250	0400	0500	0650	0800	1000
Height	H	500	520	540	560	580	780
Number of bolts		4	4	6	8	6	8
Handwheel-Ø	M	229	229	229	229	229	244
Weight	ca. kg	8.5	8.6	9.6	10.5	11.6	19.0

Dimensions in mm.

Spare Parts Actuated Valves

Type 30003 - Spare part kit



for Rubber Pneumatic Actuator

"cleaned and degreased for oxygen service"

Part No. 30003.0000.T000

suitable for:

Type	Nominal size
01353	DN15 - DN80
01653	DN15 - DN80
01753	DN15 - DN80
01853	DN15 - DN80
09343	DN25 - DN100
09443	DN25 - DN65

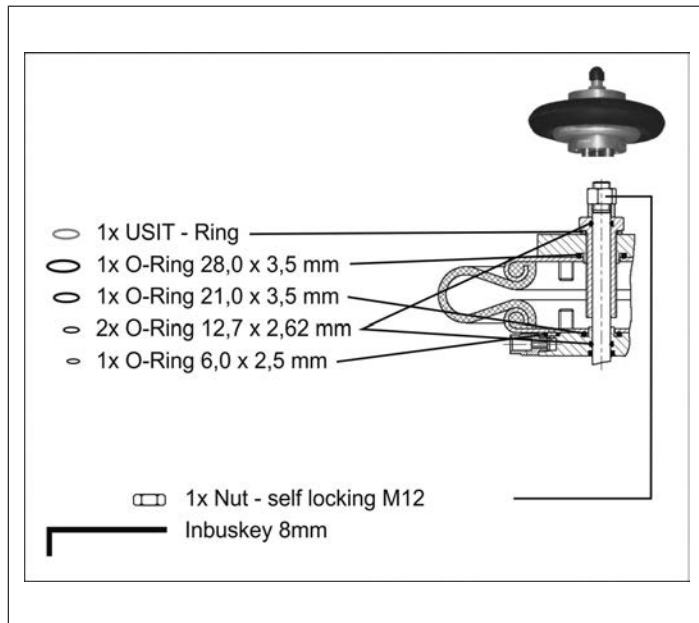

Type 30003.0000.T000	Technical data	
Nominal size	DN	15 - 100
Weight	ca. kg	0.25

Dimensions in mm.

Edition 2016-01

Pressure Regulator

Type 4186-1 - Combi-Regulator



Cryogenic-Pressure Regulator, stainless steel, PN50

Set point range from 1.0 up to 38.0 bar

Connections: male thread for union connection, BSPP (G) thread or NPT thread

Cleaning Standard: " cleaned and degreased for oxygen service " - **for oxygen (O₂) max. 30,0 bar**
complete with installed strainer screens - mesh size 0.25 mm - on connection A and B

Part No. 4186-X-1100* Set point range 1.0 up to 12.0 bar
set at 8.0 bar unless otherwise noted on purchase order

Part No. 4186-X-1200* Set point range 6.0 up to 24.0 bar
set at 12.0 bar unless otherwise noted on purchase order

Part No. 4186-X-1300* Set point range 16.0 up to 38.0 bar
set at 20.0 bar unless otherwise noted on purchase order

*connection C: 1 = M thread, 2 = BSPP (G) thread, 3 = NPT thread



Applications:

Approved for air gases, vapours and cryogenic liquefied gases incl. LNG.

Working temperature: -196°C / -321°F (77K) up to +200°C / 392°F (473K)

Ambient temperature: -40°C / -40°F (233K) up to +65°C / 149°F (338K)

Materials	DIN EN	ASTM
1 Body	1.4308	A 351 CF8
2 Bonnet (cover)	1.4408	A 351 CF8M
3 Diaphragm	1.4404	A 240 Grade 316L
4 Supporting ring	1.4301	A 276 Grade 304
5 Diaphragm ring	1.4301	A 276 Grade 304
6 Spring plate	1.4301	A 276 Grade 304
7 Spring	1.4310	A 313 Grade 301
8 Spring clamp	1.4301	A 276 Grade 304
9 Locking nut	1.4301	A 276 Grade 304
10 Set point adjuster	1.4301	A 240 Grade 304
11 Strainer (option)	1.4301	A 240 Grade 304
12 Valve seal	PTFE	
13 Bellows disc	1.4571	A 276 Grade 316Ti
14 Bellows	1.4571	A 313 Grade 316Ti
15 Bellows spring	1.4571	A 313 Grade 316Ti
16 Connection fitting	1.4571	A 276 Grade 316Ti

Standard marking acc. to Pressure Equipment Directive 97/23/EC (PED).

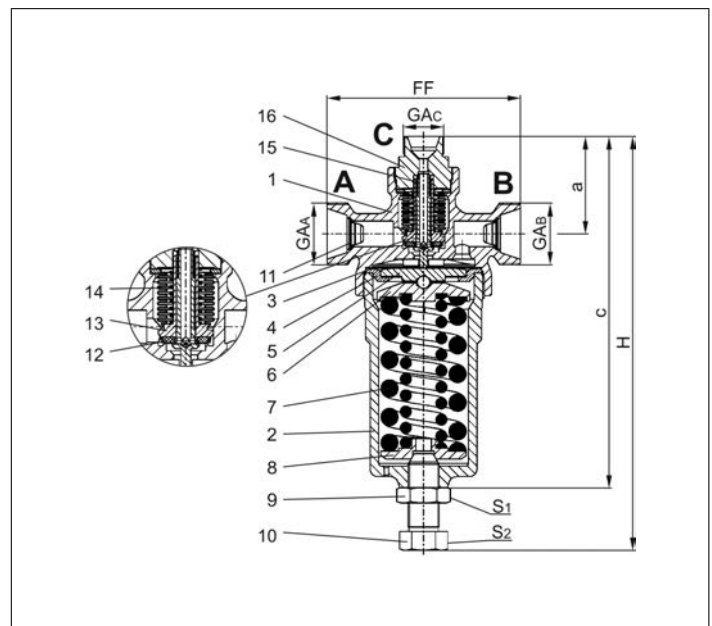

Type 4186	Technical data		
Nominal size	DN	20	20
Dimension code	.X.	MM04020	MG12000
Face-to-face dimension	FF	125	125
Height	H	268	268
Thread	GA _A	M40x2.0	G 1-1/4
Thread	GA _B	M40x2.0	G 1-1/4
Thread	GA _C	M26x1.5	G 3/4
Length	a	63	63
Length	c	227	227
Wrench size across flats	S ₁	30	30
Wrench size across flats	S ₂	27	27
Weight	ca. kg	4.3	4.3
Kvs-Value	m ³ /h	1.2	1.2
Cv-Value	gal/min	1.4	1.4

Dimensions in mm.

Essential: Please confirm pressure range and valve set pressure on purchase order

Pressure Regulator

Type 4186-3 - Combi-Regulator



Cryogenic-Pressure Regulator, stainless steel, PN40

Set point range from 2.0 up to 38.0 bar

Connections: male thread for union connection, BSPP (G) thread or NPT thread

Cleaning Standard: " cleaned and degreased for oxygen service " - **for oxygen (O₂) max. 30,0 bar**
complete with installed strainer screens - mesh size 0.25 mm - on connection A and B

Part No. 4186.X.3100* Set point range 2.0 up to 10.0 bar
set at 8.0 bar unless otherwise noted on purchase order

Part No. 4186.X.3200* Set point range 8.0 up to 22.0 bar
set at 12.0 bar unless otherwise noted on purchase order

Part No. 4186.X.3300* Set point range 20.0 up to 38.0 bar
set at 20.0 bar unless otherwise noted on purchase order

*connection C: 1 = M thread, 2 = BSPP (G) thread, 3 = NPT thread



Applications:

Approved for air gases, vapours and cryogenic liquefied gases incl. LNG.

Working temperature: -196°C / -321°F (77K) up to +200°C / 392°F (473K)

Ambient temperature: -40°C / -40°F (233K) up to +65°C / 149°F (338K)

Materials	DIN EN	ASTM
1 Body	1.4308	A 351 CF8
2 Bonnet (cover)	1.4408	A 351 CF8M
3 Bellow	1.4571	A 313 Grade 316Ti
4 Spring plate	1.4571	A 276 Grade 316Ti
5 Lift stopper	1.4571	A 276 Grade 316Ti
6 Lift stopper	1.4571	A 276 Grade 316Ti
7 Spring	1.4310	A 313 Grade 301
8 Spring clamp	1.4301	A 276 Grade 304
9 Locking nut	1.4301	A 276 Grade 304
10 Set point adjuster	1.4301	A 240 Grade 304
11 Strainer (option)	1.4301	A 240 Grade 304
12 Valve seal	PTFE	
13 Bellow disc	1.4571	A 313 Grade 316Ti
14 Bellow	1.4571	A 313 Grade 316Ti
15 Bellow spring	1.4571	A 313 Grade 316Ti
16 Connection fitting	1.4571	A 313 Grade 316Ti
17 Tubular overflow	1.4571	A 276 Grade 316Ti
18 Union nut	1.4301	A 276 Grade 304
19 Flange cover	1.4308	A 351 CF8

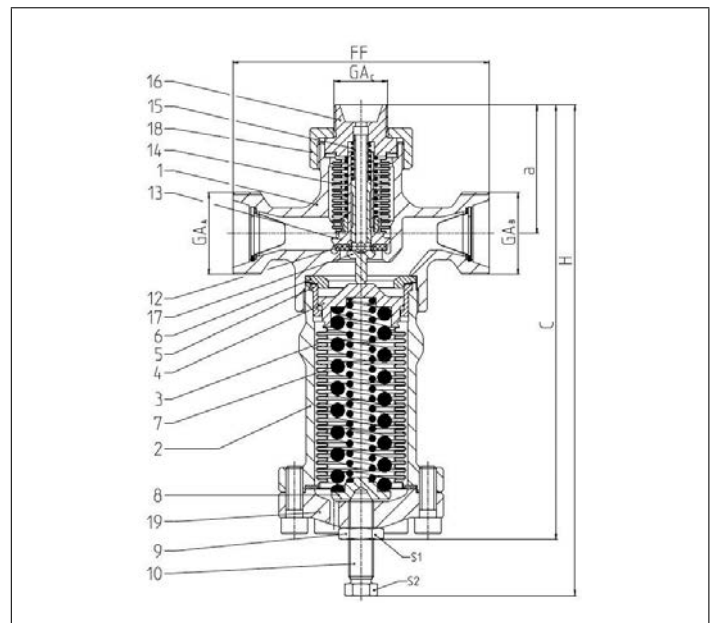

Standard marking acc. to Pressure Equipment Directive 97/23/EC (PED).



Type 4186	Technical data		
Nominal size	DN	20	20
Dimension code	.X.	MM04020	MG12000
Face-to-face dimension	FF	125	125
Height	H	239	239
Thread	GA _A	M40x2.0	G 1-1/4
Thread	GA _B	M40x2.0	G 1-1/4
Thread	GA _C	M26x1.5	G 3/4
Length	a	63	63
Length	c	212	212
Wrench size across flats	S ₁	19	19
Wrench size across flats	S ₂	14	14
Weight	ca. kg	3.2	3.2
Kvs-Value	m ³ /h	3.2	3.2
Cv-Value	gal/min	3.7	3.7

Essential: Please confirm pressure range and valve set pressure on purchase order

Dimensions in mm.

Check Valves

Type 05412 - Check Valve



Cryogenic-Check Valves, PN50

Bronze body and cap
with spring, opening pressure ca. 0.1 bar
"cleaned and degreased for oxygen service"

Part No. 05412.X.0001

Socket end for copper pipes acc. to DIN EN 12449 or ASTM B88

Available options - on request only:

- Socket end for stainless steel pipes acc. to ISO 1127



Applications:

Approved for air gases, vapours and cryogenic liquefied gases incl. LNG.
Working temperature: -196°C / -321°F (77K) up to +120°C / +248°F (393K)

Materials	DIN EN	ASTM
1 Body	CC491K	B 62 UNS C83600
2 Valve seal	PTFE / Carbon filled (25%)	
3 Disc	CW614N	B 283 UNS C38500
4 Spring	CW452K	B 159 UNS C51900
5 Bonnet gasket	PTFE	
6 Bolts	1.4301/A2 A 194 B8	
7 Cap	CC493K	B 505 UNS C93200

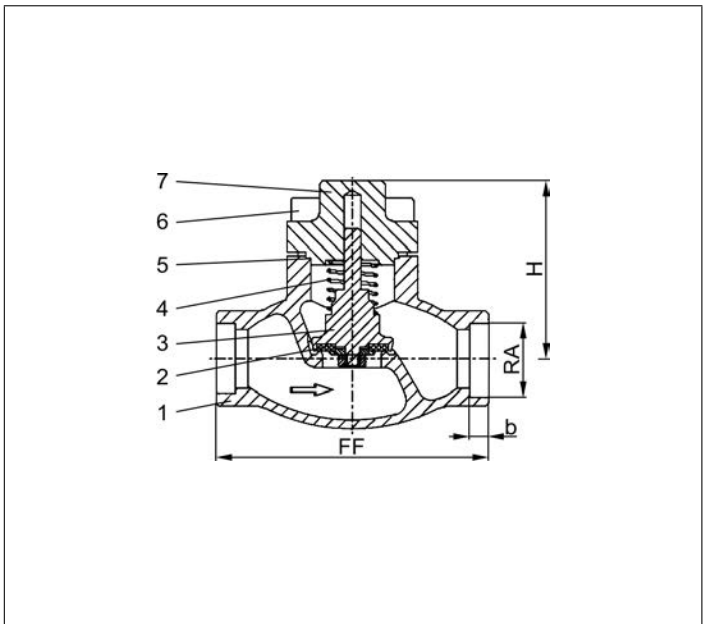

Standard marking acc. to Pressure Equipment Directive 97/23/EC (PED).



Type 05412 - Standard design	Technical data							
Nominal size	DN	10	15	20	25	32	40	50
Dimension code	.X.	X=DNRA, Example: valve DN10 for copper pipe RAØ12mm. X=1012						
Face-to-face dimension	FF	60	85	85	115	115	140	160
Height	H	71	71	72	75	87	95	95
Outside pipe-Ø	RA	dependent on order						
Socket depth	b	6	6	8	8	10	13	20
Weight	ca. kg	0.7	1.0	1.3	1.6	2.4	3.9	5.7
Kvs-Value	m ³ /h	1.6	4.3	6.7	11.5	12.1	22.6	37.1
Cv-Value	gal/min	1.9	5.0	7.8	13.4	14.1	26.3	43.2

Dimensions in mm.

Check Valves

Type 05412 - Check Valve



Cryogenic-Check Valves, PN50

Bronze body and cap
with spring, opening pressure ca. 0.1 bar
"cleaned and degreased for oxygen service"

Part No. 05412.X.0008

Complete with brazed copper stubs acc. to DIN EN 12449

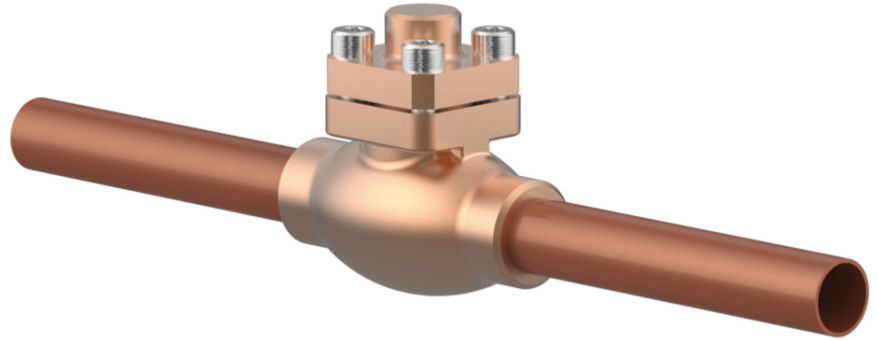

Applications:

Approved for air gases, vapours and cryogenic liquefied gases incl. LNG.
Working temperature: -196°C / -321°F (77K) up to +120°C / +248°F (393K)

Materials	DIN EN	ASTM
1 Body	CC491K	B 62 UNS C83600
2 Valve seal	PTFE / Carbon filled (25%)	
3 Disc	CW614N	B 283 UNS C38500
4 Spring	CW452K	B 159 UNS C51900
5 Bonnet gasket	PTFE	
6 Bolts	1.4301/A2 A 194 B8	
7 Cap	CC493K	B 505 UNS C93200
8 Copper stubs	CW024A	B 152 UNS C12200

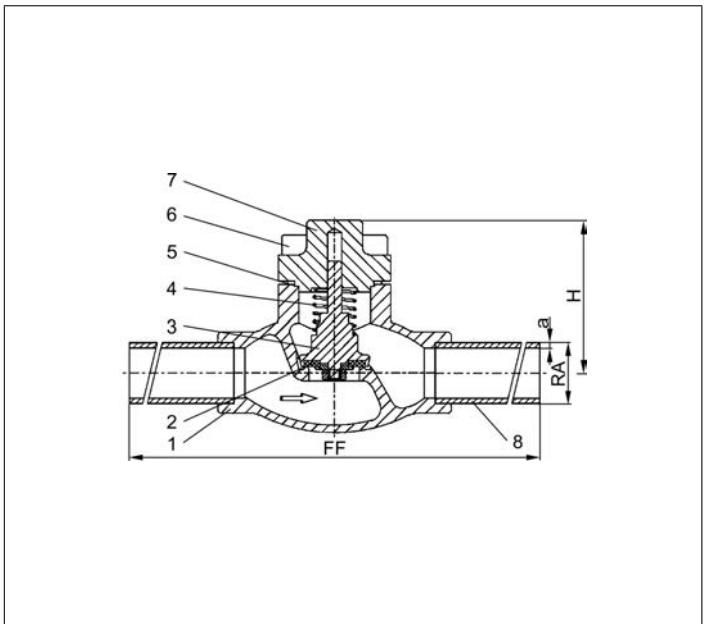

Standard marking acc. to Pressure Equipment Directive 97/23/EC (PED).



Type 05412 - Standard design	Technical data								
Nominal size	DN	10	15	15	20	25	32	40	50
Dimension code	.X.	1012	1515	1518	2022	2528	3235	4042	5054
Face-to-face dimension	FF	360	385	385	385	415	415	420	460
Height	H	71	71	71	72	75	87	95	95
Outside pipe-Ø	RA	12.0	15.0	18.0	22.0	28.0	35.0	42.0	54.0
Wall thickness pipe	a	1.0	1.5	1.5	1.5	1.5	1.5	1.5	2.0
Weight	ca. kg	0.8	1.1	1.1	1.4	2.0	2.8	4.5	6.5
Kvs-Value	m ³ /h	2.2	4.3	4.3	6.7	11.5	12.1	22.6	37.1
Cv-Value	gal/min	2.6	5.0	5.0	7.8	13.4	14.1	26.3	43.2

Dimensions in mm.

Check Valves

Type 05412 - Check Valve



Cryogenic-Check Valves, PN50

Bronze body and cap
with spring, opening pressure ca. 0.1 bar
"cleaned and degreased for oxygen service"

Part No. 05412.X.0007

Complete with brazed stainless steel stubs acc. to DIN EN 10216-5 or ASTM A312

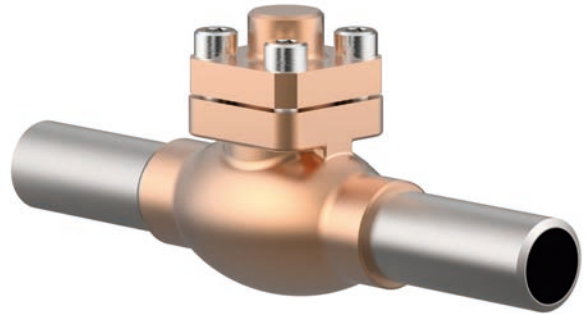

Applications:

Approved for air gases, vapours and cryogenic liquefied gases incl. LNG.
Working temperature: -196°C / -321°F (77K) up to +120°C / +248°F (393K)

Materials	DIN EN	ASTM
1 Body	CC491K	B 62 UNS C83600
2 Valve seal	PTFE / Carbon filled (25%)	
3 Disc	CW614N	B 283 UNS C38500
4 Spring	CW452K	B 159 UNS C51900
5 Bonnet gasket	PTFE	
6 Bolts	1.4301/A2 A 194 B8	
7 Cap	CC493K	B 505 UNS C93200
8 Stainless steel stubs	1.4306	A 312 TP304L

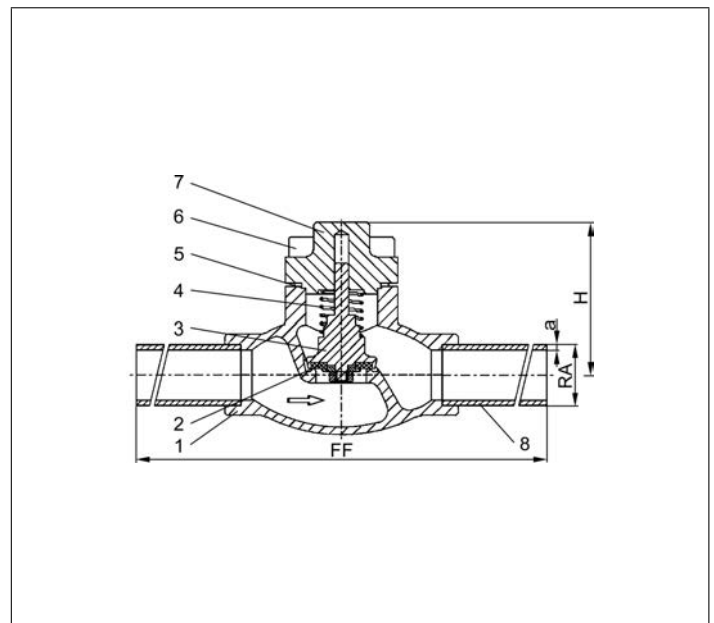

Standard marking acc. to Pressure Equipment Directive 97/23/EC (PED).



Type 05412 - Standard design	Technical data								
Nominal size	DN	10	10	15	20	25	32	40	50
Dimension code	.X.	1012	1017	1521	2027	2533	3242	4048	5060
Face-to-face dimension	FF	210	210	235	235	265	265	290	310
Height	H	71	71	71	72	75	87	95	95
Outside pipe-Ø ISO 1127	RA	12.0	17.2	21.3	26.9	33.7	42.4	48.3	60.3
Wall thickness pipe ISO 1127	a	1.0	2.3	2.6	2.9	3.2	3.2	3.6	3.6
Outside pipe-Ø ASTM A312	RA	-	17.15	21.34	26.67	33.40	42.16	48.26	60.33
Wall thickness pipe ASTM A312	a	dimensions acc. to S10 or S40							
Weight	ca. kg	0.8	0.8	1.1	1.4	2.0	2.8	4.5	6.5
Kvs-Value	m ³ /h	2.2	2.2	4.3	6.7	11.5	12.1	22.6	37.1
Cv-Value	gal/min	2.6	2.6	5.0	7.8	13.4	14.1	26.3	43.2

Dimensions in mm.

Check Valves

Type 05413 - Check Valve



Cryogenic-Check Valves, PN50

Bronze body and cap
with spring, opening pressure ca. 0.1 bar
"cleaned and degreased for oxygen service"

Part No. 05413.X.0001

Female thread connection (G) acc. to ISO 228/1

Part No. 05413.X.0006

Female thread connection NPT acc. to ANSI B 1.20.1

Available options - on request only:

- Female thread connection (R) acc. to ISO 7-Rc



Applications:

Approved for air gases, vapours and cryogenic liquefied gases incl. LNG.
Working temperature: -196°C / -321°F (77K) up to +120°C / +248°F (393K)

Materials	DIN EN	ASTM
1 Body	CC491K	B 62 UNS C83600
2 Valve seal	PTFE / Carbon filled (25%)	
3 Disc	CW614N	B 283 UNS C38500
4 Spring	CW452K	B 159 UNS C51900
5 Bonnet gasket	PTFE	
6 Bolts	1.4301/A2 A 194 B8	
7 Cap	CC493K	B 505 UNS C93200

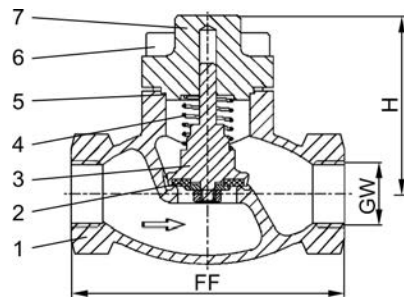

Standard marking acc. to Pressure Equipment Directive 97/23/EC (PED).



Type 05413 - Standard design	Technical data								
Nominal size	DN	10	10	15	20	25	32	40	50
Thread size	GW	1/4	3/8	1/2	3/4	1	1-1/4	1-1/2	2
Dimension code	.X.	0200	0300	0400	0600	1000	1200	1400	2000
Face-to-face dimension	FF	60	60	85	85	115	115	140	160
Height	H	71	71	71	72	75	87	95	95
Weight	ca. kg	0.7	0.7	1.0	1.3	1.6	2.4	3.9	5.7
Kvs-Value	m ³ /h	1.6	2.2	4.3	6.7	11.5	20.6	22.6	37.1
Cv-Value	gal/min	1.9	2.6	5.0	7.8	13.4	23.9	26.3	43.2

Dimensions in mm.

Check Valves

Type 05411 - Check Valve



Cryogenic-Check Valves, PN50

Bronze body and cap
with spring, opening pressure ca. 0.1 bar
"cleaned and degreased for oxygen service"

Part No. 05411.X.0001

Male thread for union connection



Applications:

Approved for air gases, vapours and cryogenic liquefied gases incl. LNG.
Working temperature: -196°C / -321°F (77K) up to +120°C / +248°F (393K)

Materials	DIN EN	ASTM
1 Body	CC491K	B 62 UNS C83600
2 Valve seal	PTFE / Carbon filled (25%)	
3 Disc	CW614N	B 283 UNS C38500
4 Spring	CW452K	B 159 UNS C51900
5 Bonnet gasket	PTFE	
6 Bolts	1.4301/A2 A 194 B8	
7 Cap	CC493K	B 505 UNS C93200

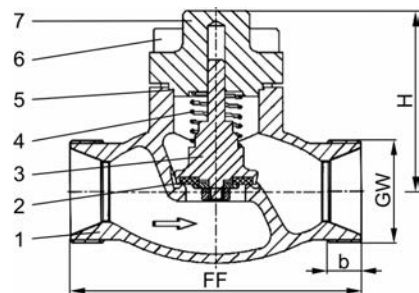

Standard marking acc. to Pressure Equipment Directive 97/23/EC (PED).



Type 05411 - Standard design	Technical data					
Nominal size	DN	10	20	32	40	50
Dimension code	.X.	0100	0200	0320	0400	0500
Face-to-face dimension	FF	60	85	115	140	160
Height	H	71	72	87	95	95
Union thread	GW	M26x1.5	M40x2.0	M55x2.0	M65x2.0	M78x2.0
Thread length	b	7	11	14	17	20
Weight	ca. kg	0.7	1.3	2.4	3.9	5.7
Kvs-Value	m ³ /h	2.2	6.7	12.1	22.6	37.1
Cv-Value	gal/min	2.6	7.8	14.1	26.3	43.2

Dimensions in mm.

Check Valves

Type 05411 - Check Valve



Cryogenic-Check Valves, PN50

Bronze body and cap
with spring, opening pressure ca. 0.1 bar
"cleaned and degreased for oxygen service"

Part No. 05411.X.0008

Completed with union type braze fittings for copper pipes acc. to DIN EN 12449 or ASTM B88

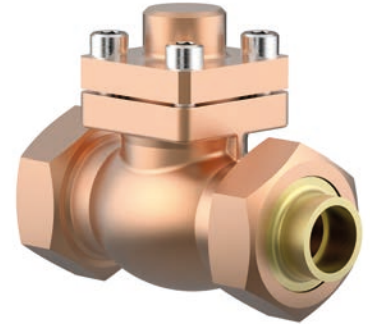

Applications:

Approved for air gases, vapours and cryogenic liquefied gases incl. LNG.
Working temperature: -196°C / -321°F (77K) up to +120°C / +248°F (393K)

Materials	DIN EN	ASTM
1 Body	CC491K	B 62 UNS C83600
2 Valve seal	PTFE / Carbon filled (25%)	
3 Disc	CW614N	B 283 UNS C38500
4 Spring	CW452K	B 159 UNS C51900
5 Bonnet gasket	PTFE	
6 Bolts	1.4301/A2 A 194 B8	
7 Cap	CC493K	B 505 UNS C93200
8 Braze fitting	CC493K	B 505 UNS C93200
9 Union nut	CC493K	B 505 UNS C93200

Standard marking acc. to Pressure Equipment Directive 97/23/EC (PED).

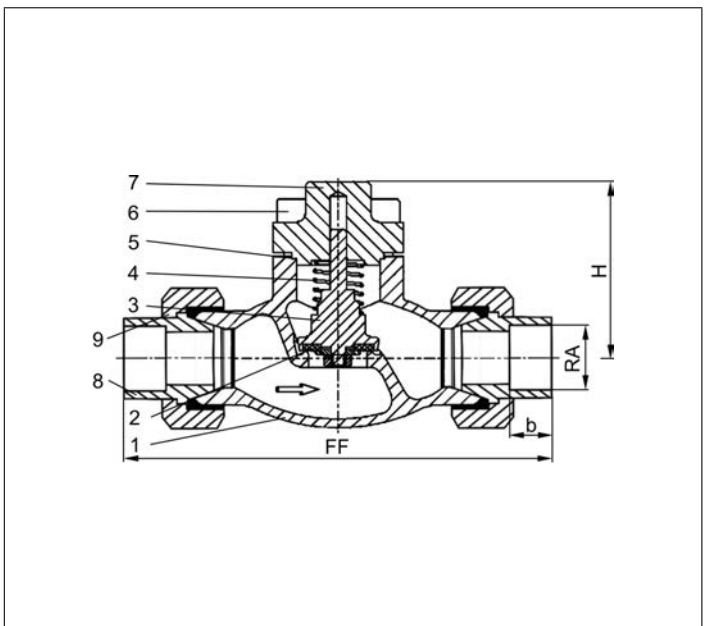

Type 05411 - Standard design	Technical data								
Nominal size	DN	10	10	20	20	32	32	40	50
Dimension code	.X.	1012	1015	1518	2022	2528	3235	4042	5054
Face-to-face dimension	FF	98	98	132	132	171	171	230	230
Height	H	71	71	72	72	87	87	95	95
Outside pipe-Ø	RA	12.0	15.0	18.0	22.0	28.0	35.0	42.0	54.0
Socket depth	b	11	11	14	14	17	17	17	17
Weight	ca. kg	0.9	0.9	2.0	2.0	3.6	3.6	6.0	8.5
Kvs-Value	m ³ /h	1.6	2.2	6.0	6.7	11.5	12.1	22.6	37.1
Cv-Value	gal/min	1.9	2.6	7.1	7.8	13.4	14.1	26.3	43.2

Dimensions in mm.

Check Valves

Type 05411 - Check Valve



Cryogenic-Check Valves, PN50

Bronze body and cap
with spring, opening pressure ca. 0.1 bar
"cleaned and degreased for oxygen service"

Part No. 05411.X.0007

Completed with union type butt weld fittings for stainless steel pipes
acc. to ISO 1127 or ASTM A312

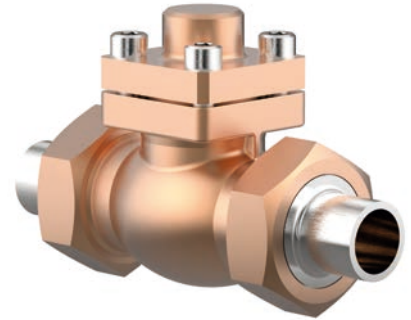

Applications:

Approved for air gases, vapours and cryogenic liquefied gases incl. LNG.
Working temperature: -196°C / -321°F (77K) up to +120°C / +248°F (393K)

Materials	DIN EN	ASTM
1 Body	CC491K	B 62 UNS C83600
2 Valve seal	PTFE / Carbon filled (25%)	
3 Disc	CW614N	B 283 UNS C38500
4 Spring	CW452K	B 159 UNS C51900
5 Bonnet gasket	PTFE	
6 Bolts	1.4301/A2 A 194 B8	
7 Cap	CC493K	B 505 UNS C93200
8 Weld fitting	1.4301	A 276 Grade 304
9 Union nut	CC493K	B 505 UNS C93200

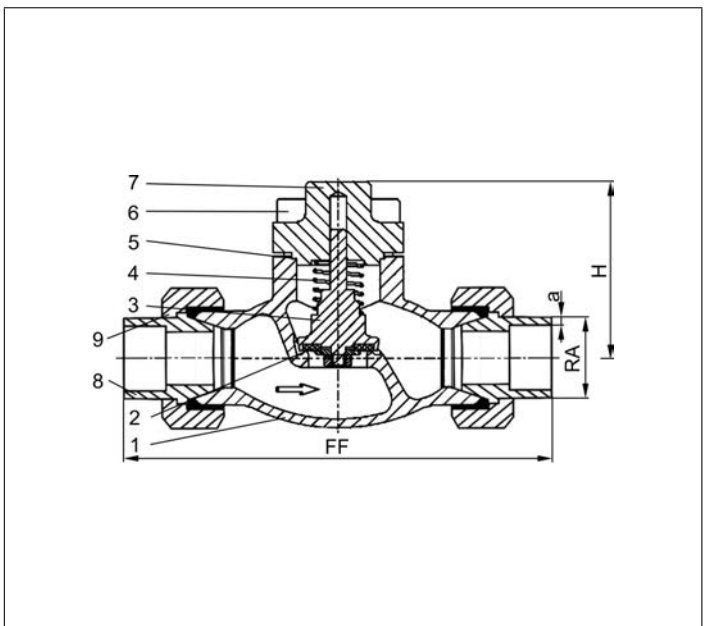

Standard marking acc. to Pressure Equipment Directive 97/23/EC (PED).



Type 05411 - Standard design	Technical data								
Nominal size	DN	10	10	20	20	32	32	40	50
Dimension code	.X.	1012	1017	1521	2027	2533	3242	4048	5060
Face-to-face dimension	FF	137	141	168	168	203	203	230	263
Height	H	71	71	72	72	87	87	95	95
Outside pipe-Ø ISO 1127	RA	12.0	17.2	21.3	26.9	33.7	42.4	48.3	60.3
Wall thickness pipe ISO 1127	a	1.0	2.3	2.6	2.0	3.2	2.0	3.6	3.6
Outside pipe-Ø ASTM A312	RA	-	17.15	21.34	26.67	33.40	42.16	48.26	60.33
Wall thickness pipe ASTM A312	a	dimensions acc. to S10 or S40							
Weight	ca. kg	0.9	0.9	2.0	2.0	3.6	3.6	6.0	8.5
Kvs-Value	m ³ /h	1.6	2.2	6.7	6.7	12.1	12.1	22.6	37.1
Cv-Value	gal/min	1.9	2.6	7.8	7.8	14.1	14.1	26.3	43.2

Dimensions in mm.

Check Valves

Type 05416 - Check Valve



Cryogenic-Check Valves, PN50 (DN100/150=PN40)

Stainless steel body and bronze cap
with spring, opening pressure ca. 0.1 bar
"cleaned and degreased for oxygen service"

Part No. 05416.X.000*

* Butt weld connection for stainless steel pipes acc. to ISO 1127 or ASTM A312

Part No. 05416.X.0004

Socket weld connection for stainless steel pipes acc. to ISO 1127 or ASTM A312

Available options - on request only:

· Welded stainless steel stubs acc. to ISO 1127 or ASTM A312 - length FF + 200mm



Applications:

Approved for air gases, vapours and cryogenic liquefied gases incl. LNG.

Working temperature: -196°C / -321°F (77K) up to +120°C / +248°F (393K)

Materials	DIN EN	ASTM
1 Body	1.4308	A 351 CF8
2 Valve seal up to DN50	PTFE / Carbon filled (25%)	
2a Valve seal from DN65	PTFE	
3 Disc	CW614N	B 283 UNS C38500
4 Spring	CW452K	B 159 UNS C51900
5 Bonnet gasket	PTFE	
6 Bolts	1.4301/A2	A 194 B8
7 Cap	CC493K	B 505 UNS C93200

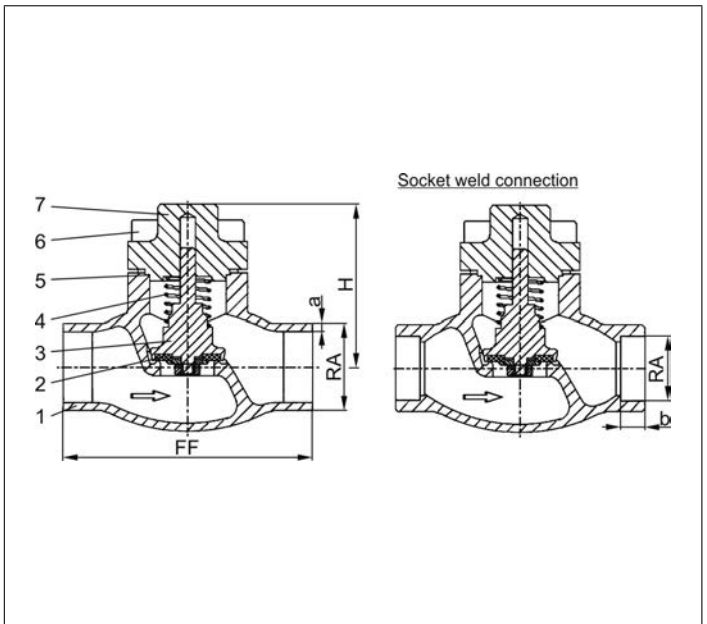

Standard marking acc. to Pressure Equipment Directive 97/23/EC (PED).



Type 05416 - Standard	Technical data														
	DN	10	15	15	20	25	32	40	40	50	65	80	100	150	
Nominal size	DN	10	15	15	20	25	32	40	40	50	65	80	100	150	
Dimension code	.X.	1012	1517	1521	2026	2533	3238	4042	4048	5060	657x	8088	0114	0168	
Face-to-face dimension	FF	70	85	85	100	115	115	130	130	155	205	245	280	400	
Height	H	71	71	71	72	75	87	95	95	95	125	150	185	215	
Outside pipe-Ø ISO 1127	RA	12.0	17.2	21.3	26.9	33.7	38.0	42.4	48.3	60.3	76.1	88.9	114.3	168.3	
Wall thickness pipe ISO 1127	a	1.0	1.6	2.0	2.0	2.0	2.0	2.0	2.0	2.0	2.6	3.2	6.0	7.1	
Outside pipe-Ø ASTM A312	RA	13.72	17.15	21.34	26.67	33.40	-	42.16	48.26	60.33	73.03	88.90	114.3	168.3	
Wall thickness pipe ASTM A312	a	dimensions acc. to S10 or S40													
Socket depth	b	6	10	10	13	13	-	13	13	16	16	16	20	20	
Weight	ca. kg	0.7	0.95	1.0	1.3	1.6	2.4	3.9	3.9	5.7	9.6	14.6	20.0	51.0	
Kvs-Value	m ³ /h	1.6	3.8	4.3	6.7	11.5	14.0	20.6	22.6	37.1	71.1	104.0	170.0	350.0	
Cv-Value	gal/min	1.9	4.4	5.0	7.8	13.4	16.2	23.9	26.3	43.2	82.7	120.9	195.2	401.8	

Dimensions in mm. Compliance of tightness requirements acc. to EN 1626 for DN150 up to 20 bar differential pressure. In the range of >20-40 bar, 350-700ml (1 bar, 20°C [68°F]) are reached.

Check Valves

Type 05415 - Check Valve



Cryogenic-Check Valves, PN50

Stainless steel body and bronze cap
with spring, opening pressure ca. 0.1 bar
"cleaned and degreased for oxygen service"

Part No. 05415.X.0001

Female thread connection (G) acc. to ISO 228/1

Part No. 05415.X.0006

Female thread connection NPT acc. to ANSI B 1.20.1

Available options - on request only:

- Female thread connection (R) acc. to ISO 7-Rc



Applications:

Approved for air gases, vapours and cryogenic liquefied gases incl. LNG.
Working temperature: -196°C / -321°F (77K) up to +120°C / +248°F (393K)

Materials	DIN EN	ASTM
1 Body	1.4308	A 351 CF8
2 Valve seal	PTFE / Carbon filled (25%)	
3 Disc	CW614N	B 283 UNS C38500
4 Spring	CW452K	B 159 UNS C51900
5 Bonnet gasket	PTFE	
6 Bolts	1.4301/A2 A 194 B8	
7 Cap	CC493K	B 505 UNS C93200

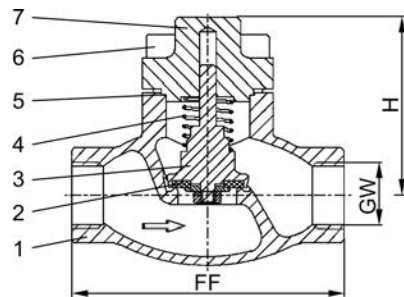

Standard marking acc. to Pressure Equipment Directive 97/23/EC (PED).



Type 05415 - Standard design	Technical data								
Nominal size	DN	10	10	15	20	25	32	40	50
Thread size	GW	1/4	3/8	1/2	3/4	1	1-1/4	1-1/2	2
Dimension code	.X.	0200	0300	0400	0600	1000	1200	1400	2000
Face-to-face dimension	FF	70	70	85	100	115	130	130	155
Height	H	71	71	71	72	75	95	95	95
Weight	ca. kg	0.7	0.7	1.0	1.3	1.6	3.9	3.9	5.7
Kvs-Value	m ³ /h	1.6	2.2	4.3	6.7	11.5	20.6	22.6	37.1
Cv-Value	gal/min	1.9	2.6	5.0	7.8	13.4	23.9	26.3	43.2

Dimensions in mm.

Check Valves

Type 05418 - Check Valve, DIN EN Flanges



Cryogenic-Check Valves, PN40

Stainless steel body and bronze cap
with spring, opening pressure ca. 0.1 bar
"cleaned and degreased for oxygen service"

Part No. 05418.X.0002

Flanged connection acc. to DIN EN 1092-1 PN40

Available options - on request only:

- Nominal sizes DN15, DN20 and DN150 with welded flange

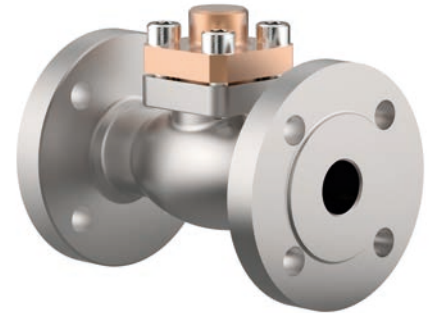

Applications:

Approved for air gases, vapours and cryogenic liquefied gases incl. LNG.

Working temperature: -196°C / -321°F (77K) up to +120°C / +248°F (393K)

Materials	DIN EN	ASTM
1 Body	1.4308	A 351 CF8
2 Valve seal up to DN50	PTFE / Carbon filled (25%)	
2a Valve seal from DN65	PTFE	
3 Disc	CW614N	B 283 UNS C38500
4 Spring	CW452K	B 159 UNS C51900
5 Bonnet gasket	PTFE	
6 Bolts	1.4301/A2	A 194 B8
7 Cap	CC493K	B 505 UNS C93200

Standard marking acc. to Pressure Equipment Directive 97/23/EC (PED).

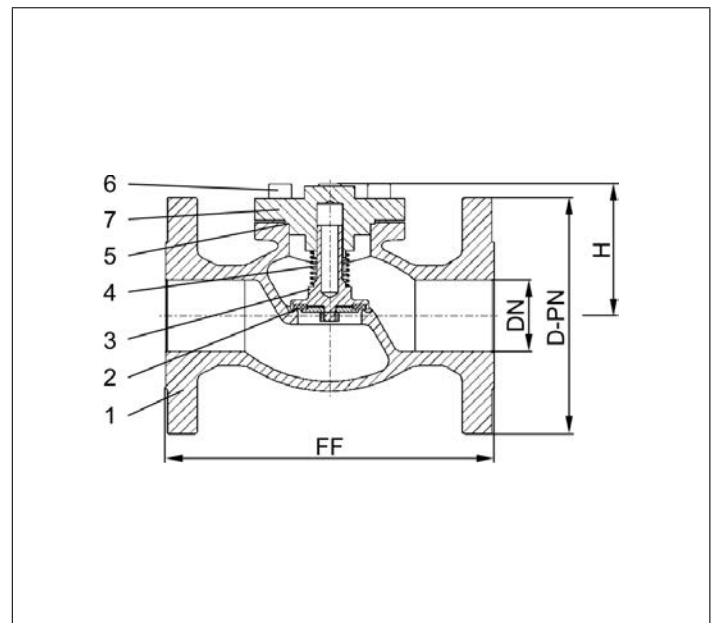

Type 05418 - Standard design	Technical data						
Nominal size	DN	25	40	50	65	80	100
Dimension code - Flange EN 1092-1 PN40	.X.	0250	0400	0500	0650	0800	1000
Flange-Ø	D-PN	115	150	165	185	200	235
Face-to-face dimension	FF	160	200	230	290	310	350
Height	H	75	95	90	125	150	165
Weight	ca. kg	4.4	6.4	11.6	19.2	25.2	39.8
Kvs-Value	m ³ /h	11.5	22.6	37.1	71.1	104.0	170.0
Cv-Value	gal/min	13.4	26.3	43.2	82.7	120.9	195.2

Dimensions in mm.

Check Valves

Type 05418 - Check Valve, ANSI Flanges



Cryogenic-Check Valves, class 300

Stainless steel body and bronze cap
with spring, opening pressure ca. 0.1 bar
"cleaned and degreased for oxygen service"

Part No. 05418.X.0003

Flanged connection acc. to ANSI B16.5 class 300

Available options - on request only:

- Nominal sizes DN15, DN20 and DN150 with welded flange

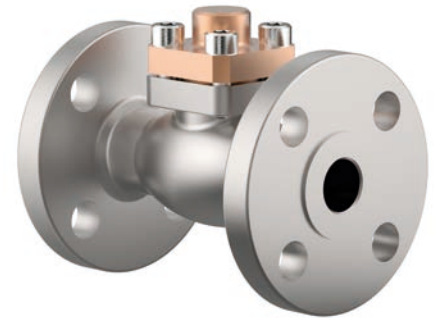

Applications:

Approved for air gases, vapours and cryogenic liquefied gases incl. LNG.

Working temperature: -196°C / -321°F (77K) up to +120°C / +248°F (393K)

Materials	DIN EN	ASTM
1 Body	1.4308	A 351 CF8
2 Valve seal up to DN50	PTFE / Carbon filled (25%)	
2a Valve seal from DN65	PTFE	
3 Disc	CW614N	B 283 UNS C38500
4 Spring	CW452K	B 159 UNS C51900
5 Bonnet gasket	PTFE	
6 Bolts	1.4301/A2	A 194 B8
7 Cap	CC493K	B 505 UNS C93200

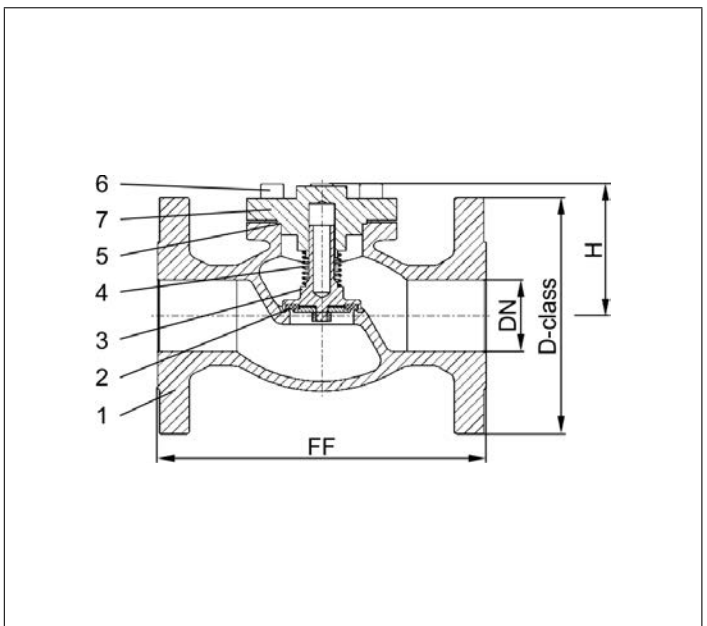

Standard marking acc. to Pressure Equipment Directive 97/23/EC (PED).



Type 05418 - Standard design	Technical data						
Nominal size	DN	25	40	50	65	80	100
Dimension code - Flange ANSI B16.5 class 300	.X.	1000	1400	2000	2400	3000	4000
Flange-Ø	D-class	123.9	155.4	165	190.5	209.5	254
Face-to-face dimension	FF	160	200	230	290	310	350
Height	H	75	95	90	125	150	165
Weight	ca. kg	4.4	6.4	11.6	19.2	25.2	39.8
Kvs-Value	m ³ /h	11.5	22.6	37.1	71.1	104.0	170.0
Cv-Value	gal/min	13.4	26.3	43.2	82.7	120.9	195.2

Dimensions in mm.

Check Valves

Type 05414 - Check Valve



Cryogenic-Check Valves, PN50 (DN100/150=PN40)

Stainless steel body and cap
with spring, opening pressure ca. 0.1 bar
"cleaned and degreased for oxygen service"

Part No. 05414.X.000*

* Butt weld connection for stainless steel pipes acc. to ISO 1127 or ASTM A312

Part No. 05414.X.0004

Socket weld connection for stainless steel pipes acc. to ISO 1127 or ASTM A312

Available options - on request only:

· Welded stainless steel stubs acc. to ISO 1127 or ASTM A312 - length FF + 200mm



Applications:

Approved for air gases, vapours and cryogenic liquefied gases incl. LNG.

Working temperature: -196°C / -321°F (77K) up to +120°C / +248°F (393K)

Materials	DIN EN	ASTM
1 Body	1.4308	A 351 CF8
2 Valve seal up to DN50	PTFE / Carbon filled (25%)	
2a Valve seal from DN65	PTFE	
3 Disc	1.4301	A 276 Grade 304
4 Spring	1.4571	A 313 Grade 316Ti
5 Bonnet gasket	PTFE	
6 Bolts	1.4301/A2	A 194 B8
7 Cap	1.4301	A 276 Grade 304

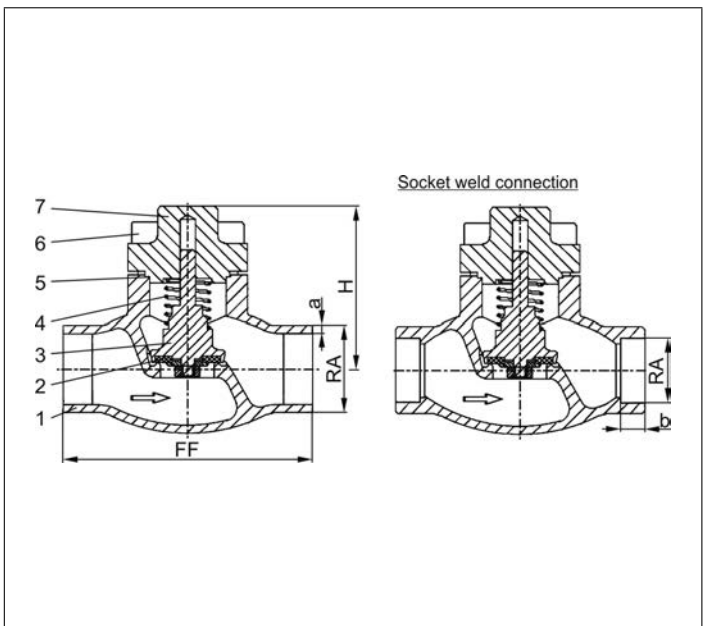

Standard marking acc. to Pressure Equipment Directive 97/23/EC (PED).



Type 05414 - Standard	Technical data														
	DN	10	15	15	20	25	32	40	40	50	65	80	100	150	
Nominal size	.X.	1012	1517	1521	2026	2533	3238	4042	4048	5060	657x	8088	0114	0168	
Dimension code	.X.	1012	1517	1521	2026	2533	3238	4042	4048	5060	657x	8088	0114	0168	
Face-to-face dimension	FF	70	85	85	100	115	115	130	130	155	205	245	280	400	
Height	H	71	71	71	72	75	87	95	95	95	125	150	185	215	
Outside pipe-Ø ISO 1127	RA	12.0	17.2	21.3	26.9	33.7	38.0	42.4	48.3	60.3	76.1	88.9	114.3	168.3	
Wall thickness pipe ISO 1127	a	1.0	1.6	2.0	2.0	2.0	2.0	2.0	2.0	2.0	2.6	3.2	6.0	7.1	
Outside pipe-Ø ASTM A312	RA	13.72	17.15	21.34	26.67	33.40	-	42.16	48.26	60.33	73.03	88.90	114.3	168.3	
Wall thickness pipe ASTM A312	a	dimensions acc. to S10 or S40													
Socket depth	b	6	10	10	13	13	-	13	13	16	16	16	20	20	
Weight	ca. kg	0.7	0.95	1.0	1.3	1.6	2.4	3.9	3.9	5.7	9.6	14.6	20.0	51.0	
Kvs-Value	m ³ /h	1.6	3.8	4.3	6.7	11.5	14.0	20.6	22.6	37.1	71.1	104.0	170.0	350.0	
Cv-Value	gal/min	1.9	4.4	5.0	7.8	13.4	16.2	23.9	26.3	43.2	82.7	120.9	195.2	401.8	

Dimensions in mm. Compliance of tightness requirements acc. to EN 1626 for DN150 up to 20 bar differential pressure. In the range of >20-40 bar, 350-700ml (1 bar, 20°C [68°F]) are reached.

Check Valves

Type 05417 - Check Valve



Cryogenic-Check Valves, PN50

Stainless steel body and cap
with spring, opening pressure ca. 0.1 bar
"cleaned and degreased for oxygen service"

Part No. 05417.X.0001

Female thread connection (G) acc. to ISO 228/1

Part No. 05417.X.0006

Female thread connection NPT acc. to ANSI B 1.20.1

Available options - on request only:

· Female thread connection (R) acc. to ISO 7-Rc



Applications:

Approved for air gases, vapours and cryogenic liquefied gases incl. LNG.

Working temperature: -196°C / -321°F (77K) up to +120°C / +248°F (393K)

Materials	DIN EN	ASTM
1 Body	1.4308	A 351 CF8
2 Valve seal	PTFE / Carbon filled (25%)	
3 Disc	1.4301	A 276 Grade 304
4 Spring	1.4571	A 313 Grade 316Ti
5 Bonnet gasket	PTFE	
6 Bolts	1.4301/A2	A 194 B8
7 Cap	1.4301	A 276 Grade 304

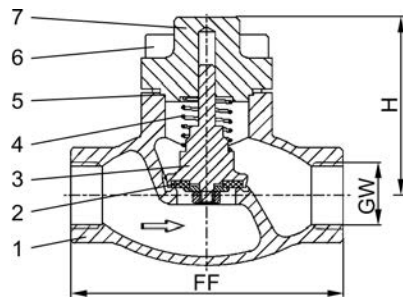

Standard marking acc. to Pressure Equipment Directive 97/23/EC (PED).



Type 05417 - Standard design	Technical data								
Nominal size	DN	10	10	15	20	25	40	40	50
Thread size	GW	1/4	3/8	1/2	3/4	1	1-1/4	1-1/2	2
Dimension code	.X.	0200	0300	0400	0600	1000	1200	1400	2000
Face-to-face dimension	FF	70	70	85	100	115	130	130	155
Height	H	71	71	71	72	75	95	95	95
Weight	ca. kg	0.7	0.7	1.0	1.3	1.6	3.9	3.9	5.7
Kvs-Value	m ³ /h	1.6	2.2	4.3	6.7	11.5	20.6	22.6	37.1
Cv-Value	gal/min	1.9	2.6	5.0	7.8	13.4	23.9	26.3	43.2

Dimensions in mm.

Check Valves

Type 05419 - Check Valve, DIN EN Flanges



Cryogenic-Check Valves, PN40

Stainless steel body and cap
with spring, opening pressure ca. 0.1 bar
"cleaned and degreased for oxygen service"

Part No. 05419.X.0002

Flanged connection acc. to DIN EN 1092-1 PN40

Available options - on request only:

- Nominal sizes DN15, DN20 and DN150 with welded flange

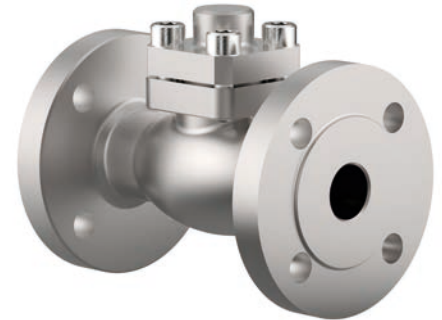

Applications:

Approved for air gases, vapours and cryogenic liquefied gases incl. LNG.

Working temperature: -196°C / -321°F (77K) up to +120°C / +248°F (393K)

Materials	DIN EN	ASTM
1 Body	1.4308	A 351 CF8
2 Valve seal up to DN50	PTFE / Carbon filled (25%)	
2a Valve seal from DN65	PTFE	
3 Disc	1.4301	A 276 Grade 304
4 Spring	1.4571	A 313 Grade 316Ti
5 Bonnet gasket	PTFE	
6 Bolts	1.4301/A2	A 194 B8
7 Cap	1.4301	A 276 Grade 304

Standard marking acc. to Pressure Equipment Directive 97/23/EC (PED).

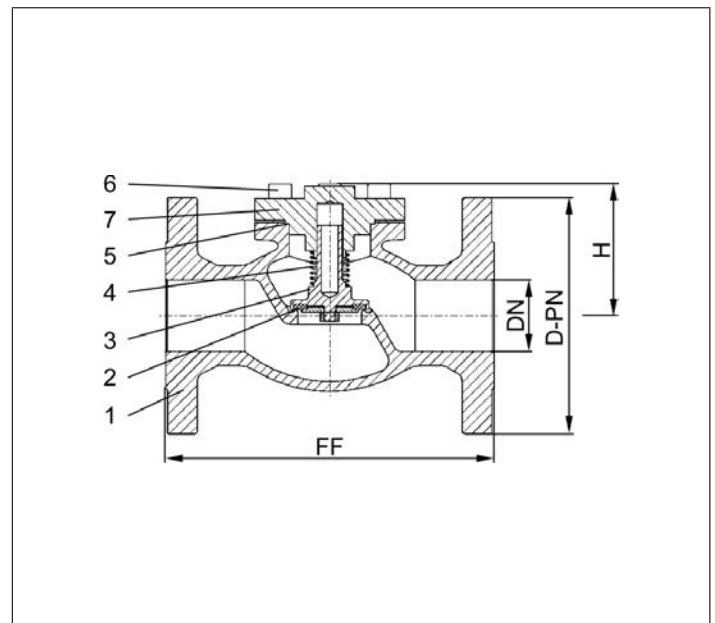

Type 05419 - Standard design	Technical data						
Nominal size	DN	25	40	50	65	80	100
Dimension code - Flange EN 1092-1 PN40	.X.	0250	0400	0500	0650	0800	1000
Flange-Ø	D-PN	115	150	165	185	200	235
Face-to-face dimension	FF	160	200	230	290	310	350
Height	H	75	95	90	125	150	165
Weight	ca. kg	4.4	6.4	11.6	19.2	25.2	39.8
Kvs-Value	m ³ /h	11.5	22.6	37.1	71.1	104.0	170.0
Cv-Value	gal/min	13.4	26.3	43.2	82.7	120.9	195.2

Dimensions in mm.

Check Valves

Type 05419 - Check Valve, ANSI Flanges



Cryogenic-Check Valves, class 300

Stainless steel body and cap
with spring, opening pressure ca. 0.1 bar
"cleaned and degreased for oxygen service"

Part No. 05419.X.0003

Flanged connection acc. to ANSI B16.5 class 300

Available options - on request only:

- Nominal sizes DN15, DN20 and DN150 with welded flange



Applications:

Approved for air gases, vapours and cryogenic liquefied gases incl. LNG.

Working temperature: -196°C / -321°F (77K) up to +120°C / +248°F (393K)

Materials	DIN EN	ASTM
1 Body	1.4308	A 351 CF8
2 Valve seal up to DN50	PTFE / Carbon filled (25%)	
2a Valve seal from DN65	PTFE	
3 Disc	1.4301	A 276 Grade 304
4 Spring	1.4571	A 313 Grade 316Ti
5 Bonnet gasket	PTFE	
6 Bolts	1.4301/A2	A 194 B8
7 Cap	1.4301	A 276 Grade 304

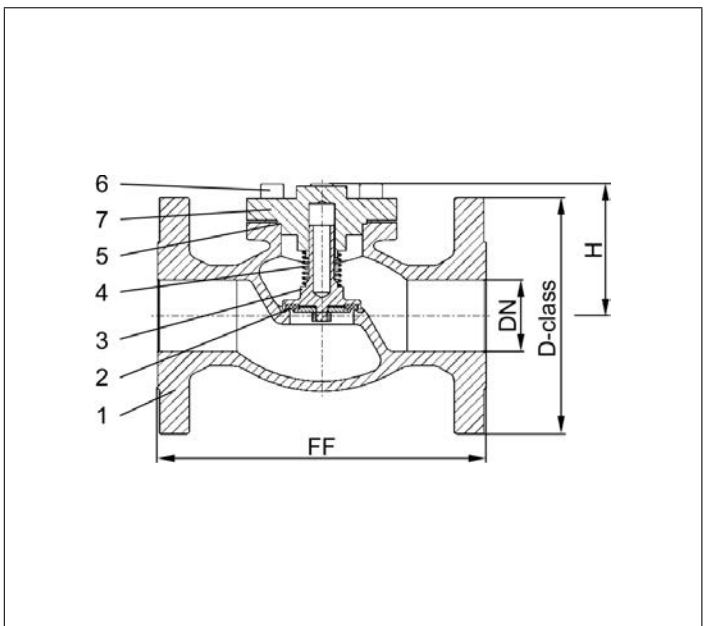

Standard marking acc. to Pressure Equipment Directive 97/23/EC (PED).



Type 05419 - Standard design	Technical data						
Nominal size	DN	25	40	50	65	80	100
Dimension code - Flange ANSI B16.5 class 300	.X.	1000	1400	2000	2400	3000	4000
Flange-Ø	D-class	123.9	155.4	165	190.5	209.5	254
Face-to-face dimension	FF	160	200	230	290	310	350
Height	H	75	95	90	125	150	165
Weight	ca. kg	4.4	6.4	11.6	19.2	25.2	39.8
Kvs-Value	m ³ /h	11.5	22.6	37.1	71.1	104.0	170.0
Cv-Value	gal/min	13.4	26.3	43.2	82.7	120.9	195.2

Dimensions in mm.

Spare Parts Check Valves

Type 28205, Type 28206 - Check Disc complete



for Cryogenic-Check Valves

brass check disc CW614N

"cleaned and degreased for oxygen service"

Part No. 28205.X.0000

suitable for:

Type	Nominal size
05411, 05412, 05413, 05415	DN10 - DN50
05416	DN10 - DN150
05418	DN25 - DN100

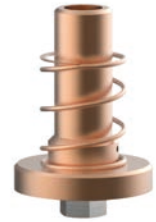
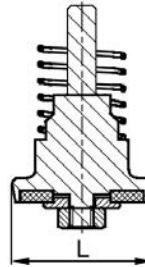

Type 28205.X.0000	Technical data											
Nominal size	DN	10	15	20	25	32	40	50	65	80	100	150
Dimension code	.X.	0100	0150	0200	0250	0320	0400	0500	0650	0800	1000	1500
Disc Ø	L	23	25	30	34.5	42	47	55	73	86	104	155
Weight	ca. kg	0.05	0.07	0.09	0.10	0.15	0.20	0.34	0.48	0.66	1.05	3.28

Dimensions in mm.

for Cryogenic-Check Valves

stainless steel check disc 1.4301

"cleaned and degreased for oxygen service"

Part No. 28206.X.0000

suitable for:

Type	Nominal size
05414	DN10 - DN150
05417	DN10 - DN50
05419	DN25 - DN100

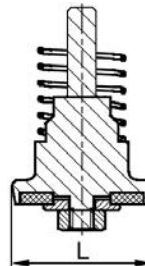

Type 28206.X.0000	Technical data											
Nominal size	DN	10	15	20	25	32	40	50	65	80	100	150
Dimension code	.X.	0100	0150	0200	0250	0320	0400	0500	0650	0800	1000	1500
Disc Ø	L	23	25	30	34.5	42	47	55	73	86	104	155
Weight	ca. kg	0.05	0.07	0.09	0.10	0.15	0.20	0.34	0.48	0.66	1.05	3.28

Dimensions in mm.

Spare Parts Check Valves

Type 30514 - Sealing spare part kit



for Cryogenic-Globe Valves

"cleaned and degreased for oxygen service"

Part No. 30514.X.0000

consisting of:

- 2x Bonnet gasket PTFE
- 1x Disc seal PTFE/Carbon filled (25%)
- 1x Disc nut 1.4301

passend zu:

Type	Nominal size
05412, 05411, 05413	DN10 - DN50
05416, 05414	DN10 - DN150
05415, 05417	DN10 - DN50
05418, 05419	DN10 - DN100

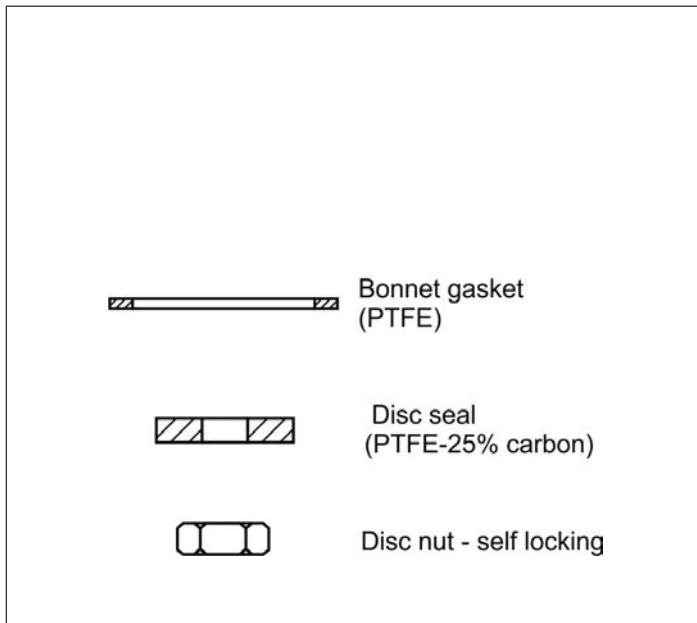
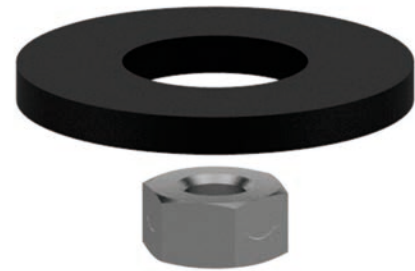

Type 30514	Technical data											
	DN	10	15	20	25	32	40	50	65	80	100	150
Dimension code	.X.	0100	0150	0200	0250	0320	0400	0500	0650	0800	1000	1500
Weight	ca. kg	0.02	0.02	0.03	0.04	0.06	0.07	0.11	0.16	0.22	0.30	0.34

Dimensions in mm.

Spare Parts Check Valves

Type 31514 - KEL-F (PCTFE) Disc Sealing spare part kit



for Cryogenic Globe Valves and Check Valves

"cleaned and degreased for oxygen service"

Part No. 31514.X.PCTFE

consisting of:

- 2x Bonnet gasket PTFE
- 1x Disc seal KEL-F (PCTFE)
- 1x Disc nut 1.4301

suitable for disc's for the following types:

Type	Nominal size
05412, 05411, 05413	DN10 - DN50
05416, 05414	DN10 - DN100
05415, 05417	DN10 - DN50
05418, 05419	DN10 - DN100

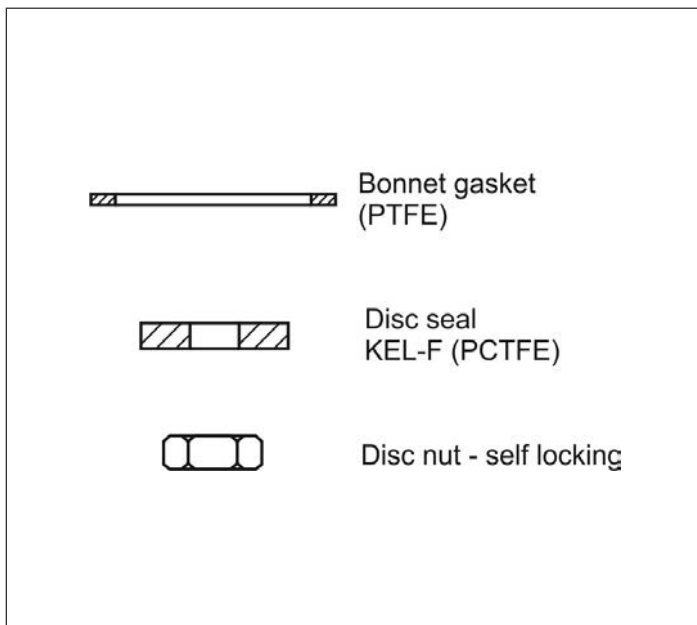

Type 31514	Technical data										
Nominal size	DN	10	15	20	25	32	40	50	65	80	100
Dimension code	.X.	0100	0150	0200	0250	0320	0400	0500	0650	0800	1000
Weight	ca. kg	0.02	0.02	0.03	0.04	0.06	0.07	0.11	0.16	0.22	0.30

Dimensions in mm.

Edition 2016-01

Strainer

Type 08411 - Strainer



Cryogenic-Strainer, PN50

Bronze body and cap
with strainer screen mesh size 0.25 mm
"cleaned and degreased for oxygen service"

Part No. 08411.X.0001

Male thread for union connection

Available options - on request only:

- other mesh sizes for strainer screen (changed flow coefficient)
- strainer screen in bronze or monel
- sintered filter in bronze or stainless steel in various porosities

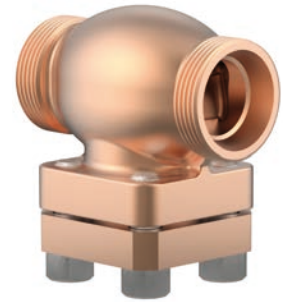

Applications:

Approved for air gases, vapours and cryogenic liquefied gases incl. LNG.
Working temperature: -196°C / -321°F (77K) up to +120°C / +248°F (393K)

Materials	DIN EN	ASTM
1 Body	CC491K	B 62 UNS C83600
2 Strainer screen	1.4301	A 240 Grade 304
3 Bonnet gasket	PTFE	
4 Bolts	1.4301/A2	A 194 B8
5 Cap	CC493K	B 505 UNS C93200

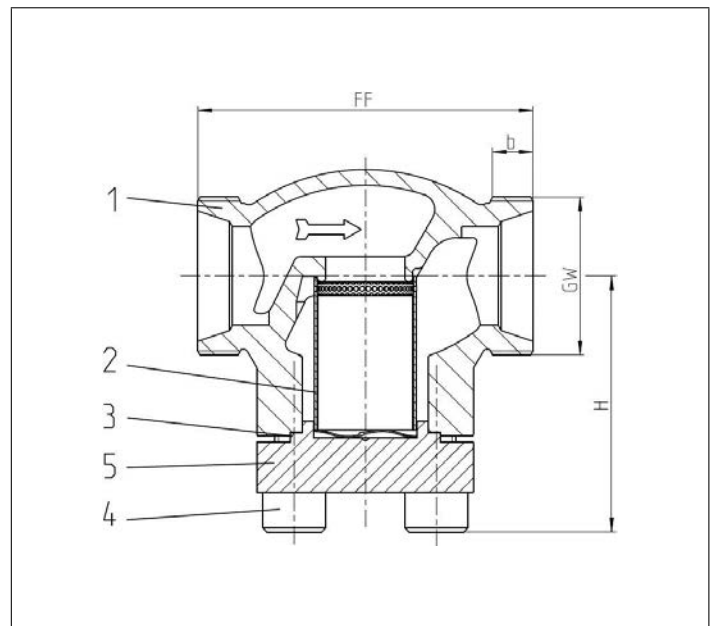

Standard marking acc. to Pressure Equipment Directive 97/23/EC (PED).



Type 08411 - Standard design	Technical data					
Nominal size	DN	10	20	32	40	50
Dimension code	.X.	0100	0200	0320	0400	0500
Face-to-face dimension	FF	60	85	115	140	160
Height	H	62	65	76	89	89
Union thread	GW	M26x1.5	M40x2.0	M55x2.0	M65x2.0	M78x2.0
Thread length	b	10	11	14	17	20
Weight	ca. kg	0.6	0.9	1.8	3.1	4.7
Kvs - Value	m ³ /h	1.5	6.5	14.0	21.0	28.0
Cv - Value	gal/min	1.7	7.5	16.2	24.3	32.4

Dimensions in mm.

Strainer

Type 08411 - Strainer



Cryogenic-Strainer, PN50

Bronze body and cap
with strainer screen mesh size 0.25 mm
"cleaned and degreased for oxygen service"

Part No. 08411.X.0008

Completed with union type braze fittings for copper pipes acc. to DIN EN 12449 or ASTM B88

Available options - on request only:

- other mesh sizes for strainer screen (changed flow coefficient)
- strainer screen in bronze or monel
- sintered filter in bronze or stainless steel in various porosities

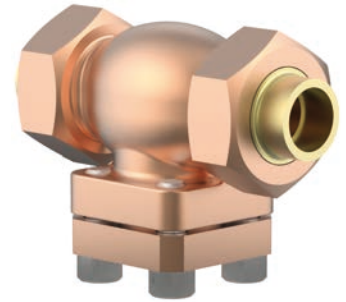

Applications:

Approved for air gases, vapours and cryogenic liquefied gases incl. LNG.
Working temperature: -196°C / -321°F (77K) up to +120°C / +248°F (393K)

Materials	DIN EN	ASTM
1 Body	CC491K	B 62 UNS C83600
2 Strainer screen	1.4301	A 240 Grade 304
3 Bonnet gasket	PTFE	
4 Bolts	1.4301/A2	A 194 B8
5 Cap	CC493K	B 505 UNS C93200
6 Braze fitting	CC493K	B 505 UNS C93200
7 Union nut	CC493K	B 505 UNS C93200

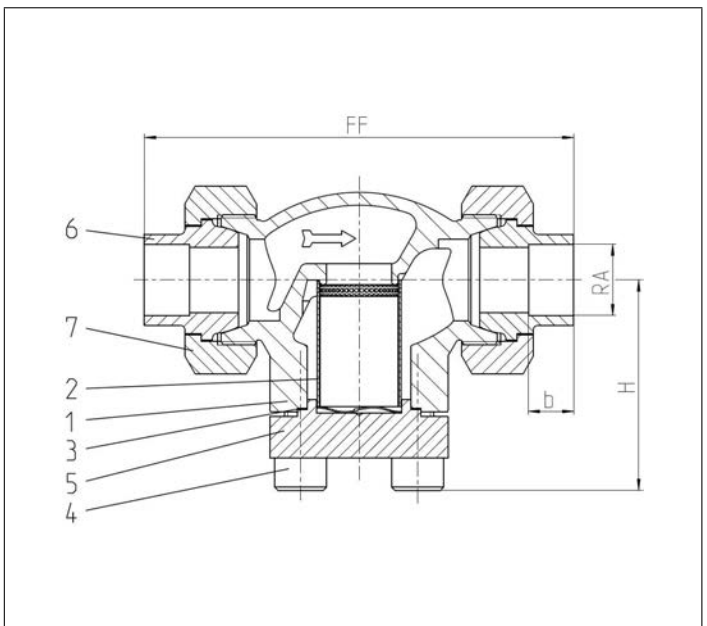

Standard marking acc. to Pressure Equipment Directive 97/23/EC (PED).



Type 08411 - Standard design	Technical data								
Nominal size	DN	10	10	15	20	25	32	40	50
Dimension code	.X.	1012	1015	1518	2022	2528	3235	4042	5054
Face-to-face dimension	FF	98	98	132	132	171	171	230	230
Height	H	62	62	62	65	69	76	89	89
Outside pipe-Ø	RA	12.0	15.0	18.0	22.0	28.0	35.0	42.0	54.0
Socket depth	b	11	11	14	14	17	17	17	17
Weight	ca. kg	0.6	0.6	0.8	0.9	1.2	1.8	3.1	4.7
Kvs - Value	m ³ /h	1.5	1.5	3.4	6.5	9.5	14.0	21.0	28.0
Cv - Value	gal/min	1.7	1.7	3.9	7.5	11.0	16.2	24.3	32.4

Dimensions in mm.

Strainer

Type 08411 - Strainer



Cryogenic-Strainer, PN50

Bronze body and cap
with strainer screen mesh size 0.25 mm
"cleaned and degreased for oxygen service"

Part No. 08411.X.0007

Completed with union type butt weld fittings for stainless steel pipes
acc. to ISO 1127 or ASTM A312

Available options - on request only:

- other mesh sizes for strainer screen (changed flow coefficient)
- strainer screen in bronze or monel
- sintered filter in bronze or stainless steel in various porosities

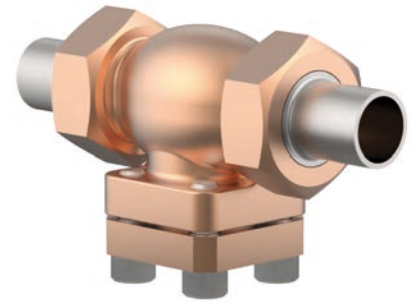

Applications:

Approved for air gases, vapours and cryogenic liquefied gases incl. LNG.
Working temperature: -196°C / -321°F (77K) up to +120°C / +248°F (393K)

Materials	DIN EN	ASTM
1 Body	CC491K	B 62 UNS C83600
2 Strainer screen	1.4301	A 240 Grade 304
3 Bonnet gasket	PTFE	
4 Bolts	1.4301/A2	A 194 B8
5 Cap	CC493K	B 505 UNS C93200
6 Weld fitting	1.4301	A 276 Grade 304
7 Union nut	CC493K	B 505 UNS C93200

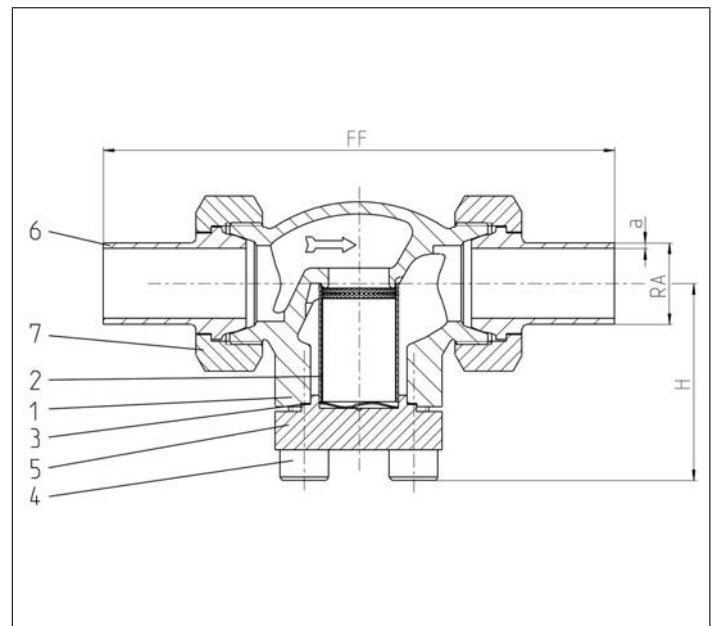

Standard marking acc. to Pressure Equipment Directive 97/23/EC (PED).



Type 08411 - Standard design	Technical data								
Nominal size	DN	10	10	20	20	32	32	40	50
Dimension code	.X.	1012	1017	1521	2027	2533	3242	4048	5060
Face-to-face dimension	FF	137	141	168	168	203	203	230	263
Outside pipe-Ø ISO 1127	RA	12.0	17.2	21.3	26.9	33.7	42.4	48.3	60.3
Wall thickness pipe ISO 1127	a	1.0	2.3	2.6	2.0	3.2	2.0	3.6	3.6
Outside pipe-Ø ASTM A312	RA	-	17.15	21.34	26.67	33.40	42.16	48.26	60.33
Wall thickness pipe ASTM A312	a	dimensions acc. to S10 or S40							
Height	H	62	62	62	65	69	76	89	89
Weight	ca. kg	0.6	0.6	0.8	0.9	1.2	1.8	3.1	4.7
Kvs - Value	m ³ /h	1.6	2.2	6.7	6.7	12.1	12.1	22.6	37.1
Cv - Value	gal/min	1.9	2.6	7.8	7.8	14.1	14.1	26.3	43.2

Dimensions in mm.

Strainer

Type 08412 - Strainer



Cryogenic-Strainer, PN50

Bronze body and cap
with strainer screen mesh size 0.25 mm
"cleaned and degreased for oxygen service"

Part No. 08412.X.0001

Socket end for copper pipes acc. to DIN EN 12449 or ASTM B88

Available options - on request only:

- Socket end for stainless steel pipes acc. to ISO 1127
- other mesh sizes for strainer screen (changed flow coefficient)
- strainer screen in bronze or monel
- sintered filter in bronze or stainless steel in various porosities

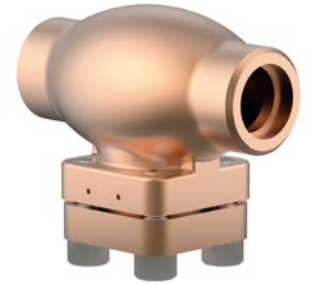

Applications:

Approved for air gases, vapours and cryogenic liquefied gases incl. LNG.
Working temperature: -196°C / -321°F (77K) up to +120°C / +248°F (393K)

Materials	DIN EN	ASTM
1 Body	CC491K	B 62 UNS C83600
2 Sieb	1.4301	A 240 Grade 304
3 Bonnet gasket	PTFE	
4 Bolts	1.4301/A2	A 194 B8
5 Cap	CC493K	B 505 UNS C93200

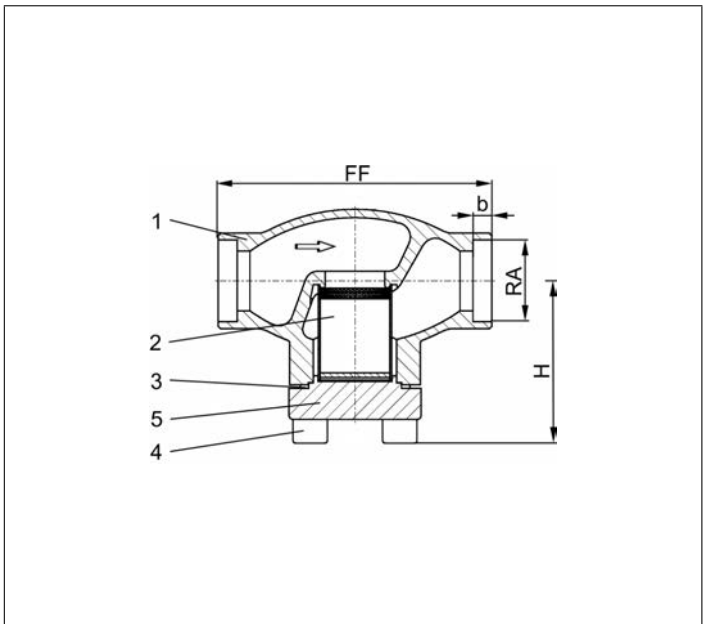

Standard marking acc. to Pressure Equipment Directive 97/23/EC (PED).



Type 08412 - Standard design	Technical data							
Nominal size	DN	10	15	20	25	32	40	50
Dimension code	.X.	X=DNRA, Example: valve DN10 for copper pipe RAø12mm, X=1012						
Face-to-face dimension	FF	60	85	85	115	115	140	160
Height	H	62	62	65	69	76	89	89
Outside pipe-Ø	RA	dependent on order						
Socket depth	b	6	6	8	8	10	13	20
Weight	ca. kg	0.6	0.8	0.9	1.2	1.8	3.1	4.7
Kvs-Value	m ³ /h	1.5	3.4	6.5	9.5	14.0	21.0	28.0
Cv-Value	gal/min	1.7	3.9	7.5	11.0	16.2	24.3	32.4

Dimensions in mm.

Strainer

Type 08412 - Strainer



Cryogenic-Strainer, PN50

Bronze body and cap
with strainer screen mesh size 0.25 mm
"cleaned and degreased for oxygen service"

Part No. 08412.X.0008

Complete with brazed copper stubs acc. to DIN EN 12449

Available options - on request only:

- other mesh sizes for strainer screen (changed flow coefficient)
- strainer screen in bronze or monel
- sintered filter in bronze or stainless steel in various porosities

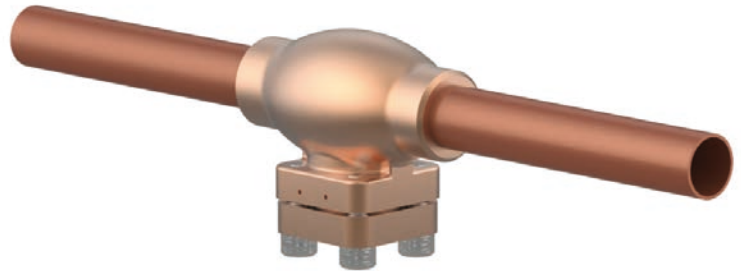

Applications:

Approved for air gases, vapours and cryogenic liquefied gases incl. LNG.
Working temperature: -196°C / -321°F (77K) up to +120°C / +248°F (393K)

Materials	DIN EN	ASTM
1 Body	CC491K	B 62 UNS C83600
2 Strainer screen	1.4301	A 240 Grade 304
3 Bonnet gasket	PTFE	
4 Bolts	1.4301/A2	A 194 B8
5 Cap	CC493K	B 505 UNS C93200
6 Copper stubs	CW024A	B 152 UNS C12200

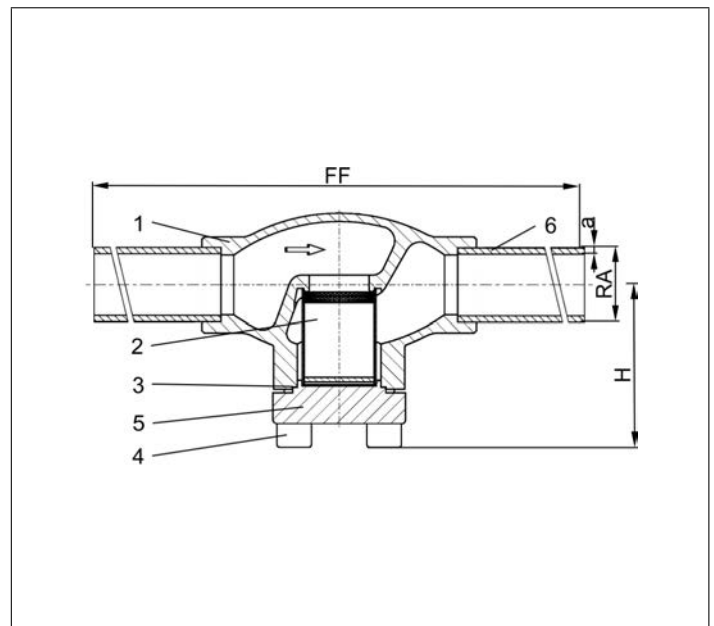

Standard marking acc. to Pressure Equipment Directive 97/23/EC (PED).



Type 08412 - Standard design	Technical data								
Nominal size	DN	10	15	15	20	25	32	40	50
Dimension code	.X.	1012	1515	1518	2022	2528	3235	4042	5054
Face-to-face dimension	FF	360	385	385	385	415	415	420	460
Height	H	62	62	62	65	69	76	89	89
Outside pipe-Ø	RA	12.0	15.0	18.0	22.0	28.0	35.0	42.0	54.0
Wall thickness pipe	a	1.0	1.5	1.5	1.5	1.5	1.5	1.5	2.0
Weight	ca. kg	0.75	1.0	1.0	1.2	1.8	2.5	4.1	6.0
Kvs-Value	m ³ /h	1.5	3.4	3.4	6.5	9.5	14.0	21.0	28.0
Cv-Value	gal/min	1.7	3.9	3.9	7.5	11.0	16.2	24.3	32.4

Dimensions in mm.

Strainer

Type 08412 - Strainer



Cryogenic-Strainer, PN50

Bronze body and cap
with strainer screen mesh size 0.25 mm
"cleaned and degreased for oxygen service"

Part No. 08412.X.0007

Complete with brazed stainless steel stubs acc. to DIN EN 10216-5 or ASTM A312

Available options - on request only:

- other mesh sizes for strainer screen (changed flow coefficient)
- strainer screen in bronze or monel
- sintered filter in bronze or stainless steel in various porosities

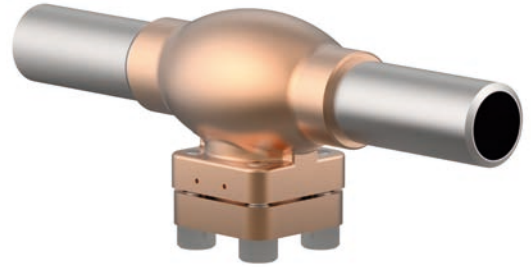

Applications:

Approved for air gases, vapours and cryogenic liquefied gases incl. LNG.
Working temperature: -196°C / -321°F (77K) up to +120°C / +248°F (393K)

Materials	DIN EN	ASTM
1 Body	CC491K	B 62 UNS C83600
2 Strainer screen	1.4301	A 240 Grade 304
3 Bonnet gasket	PTFE	
4 Bolts	1.4301/A2	A 194 B8
5 Cap	CC493K	B 505 UNS C93200
6 Stainless steel stubs	1.4306	A 312 TP304L

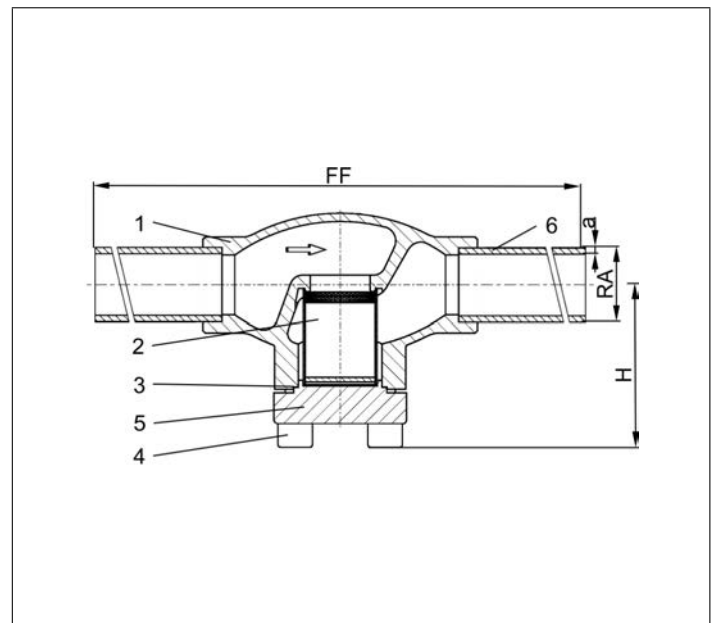

Standard marking acc. to Pressure Equipment Directive 97/23/EC (PED).



Type 08412 - Standard design	Technical data								
Nominal size	DN	10	10	15	20	25	32	40	50
Dimension code	.X.	1012	1017	1521	2027	2533	3242	4048	5060
Face-to-face dimension	FF	210	210	235	235	265	265	290	310
Height	H	62	62	62	65	69	76	89	89
Outside pipe-Ø ISO 1127	RA	12.0	17.2	21.3	26.9	33.7	42.4	48.3	60.3
Wall thickness pipe ISO 1127	a	1.0	2.3	2.6	2.9	3.2	3.2	3.6	3.6
Outside pipe-Ø ASTM A312	RA	-	17.15	21.34	26.67	33.4	42.16	48.26	60.33
Wall thickness pipe ASTM A312	a	dimensions acc. to S10 or S40							
Weight	ca. kg	0.75	0.75	1.0	1.2	1.8	2.5	4.1	6.0
Kvs-Value	m ³ /h	1.5	1.5	3.4	6.5	9.5	14.0	21.0	28.0
Cv-Value	gal/min	1.7	1.7	3.9	7.5	11.0	16.2	24.3	32.4

Dimensions in mm.

Strainer

Type 08413 - Strainer



Cryogenic-Strainer, PN50

Bronze body and cap
with strainer screen mesh size 0.25 mm
"cleaned and degreased for oxygen service"

Part No. 08413.X.0001

Female thread connection (G) acc. to ISO 228/1

Part No. 08413.X.0006

Female thread connection NPT acc. to ANSI B 1.20.1

Available options - on request only:

- Female thread connection (R) acc. to ISO 7-Rc
- other mesh sizes for strainer screen (changed flow coefficient)
- strainer screen in bronze or monel
- sintered filter in bronze or stainless steel in various porosities

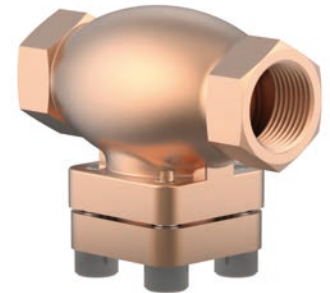

Applications:

Approved for air gases, vapours and cryogenic liquefied gases incl. LNG.
Working temperature: -196°C / -321°F (77K) up to +120°C / +248°F (393K)

Materials	DIN EN	ASTM
1 Body	CC491K	B 62 UNS C83600
2 Strainer screen	1.4301	A 240 Grade 304
3 Bonnet gasket	PTFE	
4 Bolts	1.4301/A2	A 194 B8
5 Cap	CC493K	B 505 UNS C93200

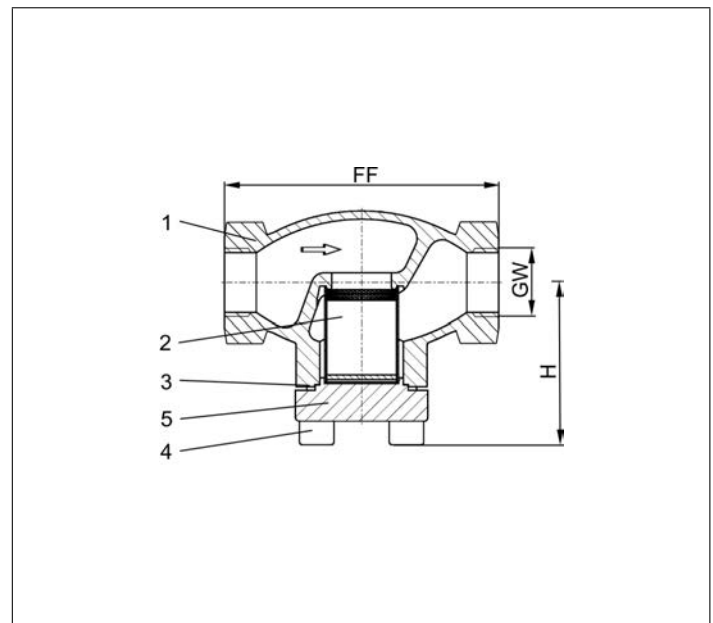

Standard marking acc. to Pressure Equipment Directive 97/23/EC (PED).



Type 08413 - Standard design	Technical data								
Nominal size	DN	10	10	15	20	25	32	40	50
Thread size	GW	1/4	3/8	1/2	3/4	1	1-1/4	1-1/2	2
Dimension code	.X.	0200	0300	0400	0600	1000	1200	1400	2000
Face-to-face dimension	FF	60	60	85	85	115	115	140	160
Height	H	62	62	62	65	69	76	89	89
Weight	ca. kg	0.6	0.6	0.8	0.9	1.2	1.8	3.1	4.7
Kvs-Value	m ³ /h	1.5	1.5	3.4	6.5	9.5	14.0	21.0	28.0
Cv-Value	gal/min	1.7	1.7	3.9	7.5	11.0	16.2	24.3	32.4

Dimensions in mm.

Strainer

Type 08414 - Strainer



Cryogenic-Strainer, PN50 (DN100/150=PN40)

Stainless steel body and bronze cap
with strainer screen mesh size 0.25 mm
"cleaned and degreased for oxygen service"

Part No. 08414.X.000*

* Butt weld connection for stainless steel pipes acc. to ISO 1127 or ASTM A312

Part No. 08414.X.0004

Socket weld connection for stainless steel pipes acc. to ISO 1127 or ASTM A312

Available options - on request only:

- Welded stainless steel stubs acc. to ISO 1127 or ASTM A312 - length FF + 200mm
- other mesh sizes for strainer screen (changed flow coefficient)
- strainer screen in bronze or monel
- sintered filter in bronze or stainless steel in various porosities



Applications:

Approved for air gases, vapours and cryogenic liquefied gases incl. LNG.

Working temperature: -196°C / -321°F (77K) up to +120°C / +248°F (393K)

Materials	DIN EN	ASTM
1 Body	1.4308	A 351 CF8
2 Strainer screen	1.4301	A 240 Grade 304
3 Bonnet gasket	PTFE	
4 Bolts	1.4301/A2	A 194 B8
5 Cap	CC493K	B 505 UNS C93200

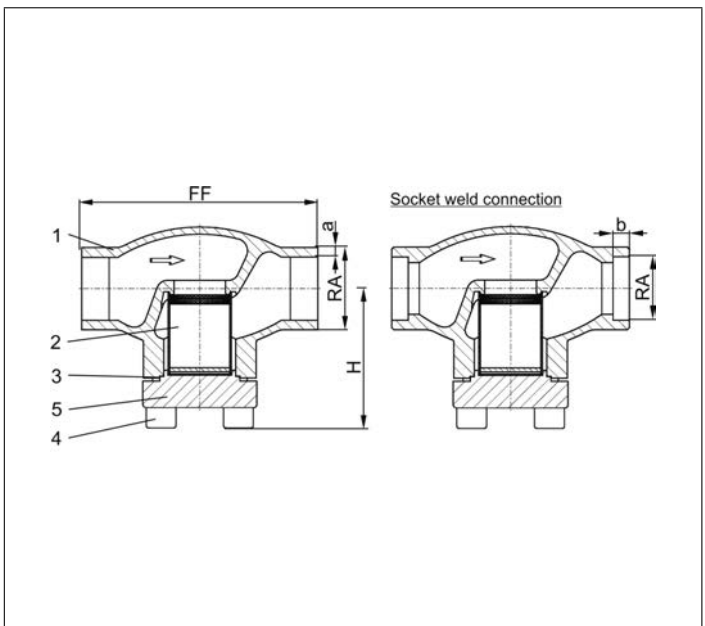

Standard marking acc. to Pressure Equipment Directive 97/23/EC (PED).



Type 08414 - Standard	Technical data													
	DN	10	15	15	20	25	32	40	40	50	65	80	100	150
Nominal size	.X.	1012	1517	1521	2026	2533	3238	4042	4048	5060	657x	8088	0114	0168
Dimension code	.X.	1012	1517	1521	2026	2533	3238	4042	4048	5060	657x	8088	0114	0168
Face-to-face dimension	FF	70	85	85	100	115	115	130	130	155	205	245	280	400
Height	H	62	62	62	65	69	76	89	89	89	125	150	166	215
Outside pipe-Ø ISO 1127	RA	12.0	17.2	21.3	26.9	33.7	38.0	42.4	48.3	60.3	76.1	88.9	114.3	168.3
Wall thickness pipe ISO 1127	a	1.0	1.6	2.0	2.0	2.0	2.0	2.0	2.0	2.0	2.6	3.2	6.0	7.1
Outside pipe-Ø ASTM A312	RA	13.72	17.15	21.34	26.67	33.40	-	42.16	48.26	60.33	73.03	88.90	114.3	168.3
Wall thickness pipe ASTM A312	a	dimensions acc. to S10 or S40												
Socket depth	b	6	10	10	13	13	-	13	13	16	16	16	20	20
Weight	ca. kg	0.6	0.75	0.8	0.9	1.2	1.8	3.1	3.1	4.7	8.9	13.6	18.0	48.0
Kvs-Value	m ³ /h	1.5	3.4	3.4	6.5	9.5	14.0	19.0	21.0	28.0	62.0	90.0	118.0	300.0
Cv-Value	gal/mir	1.7	3.9	3.9	7.5	11.0	16.2	22.0	24.3	32.4	71.7	104.0	136.4	346.8

Dimensions in mm. Compliance of tightness requirements acc. to EN 1626 for DN150 up to 20 bar differential pressure. In the range of >20-40 bar, 350-700ml (1 bar, 20°C [68°F]) are reached.

Strainer

Type 08415 - Strainer



Cryogenic-Strainer, PN50

Stainless steel body and bronze cap
with strainer screen mesh size 0.25 mm
"cleaned and degreased for oxygen service"

Part No. 08415.X.0001

Female thread connection (G) acc. to ISO 228/1

Part No. 08415.X.0006

Female thread connection NPT acc. to ANSI B 1.20.1

Available options - on request only:

- Female thread connection (R) acc. to ISO 7-Rc
- other mesh sizes for strainer screen (changed flow coefficient)
- strainer screen in bronze or monel
- sintered filter in bronze or stainless steel in various porosities



Applications:

Approved for air gases, vapours and cryogenic liquefied gases incl. LNG.
Working temperature: -196°C / -321°F (77K) up to +120°C / +248°F (393K)

Materials	DIN EN	ASTM
1 Body	1.4308	A 351 CF8
2 Sieb	1.4301	A 240 Grade 304
3 Bonnet gasket	PTFE	
4 Capschrauben	1.4301/A2	A 194 B8
5 Cap	CC493K	B 505 UNS C93200

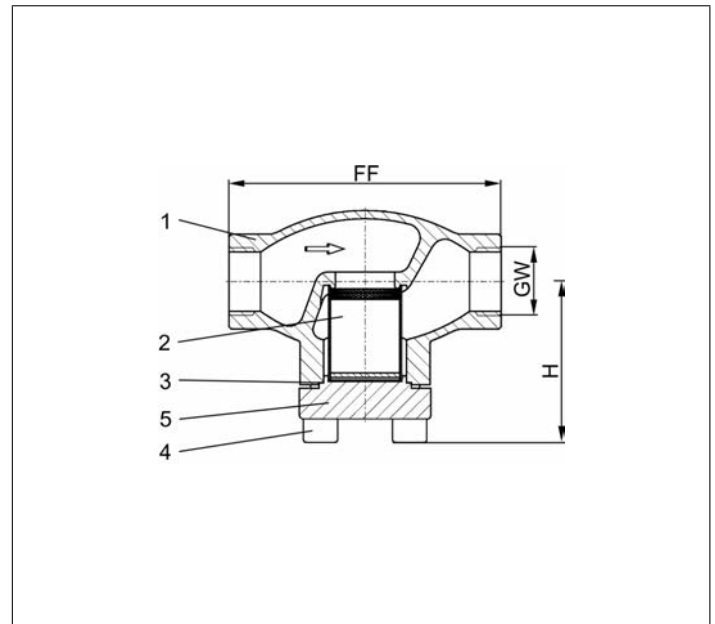

Standard marking acc. to Pressure Equipment Directive 97/23/EC (PED).



Type 08415 - Standard design	Technical data								
Nominal size	DN	10	10	15	20	25	40	40	50
Thread size	GW	1/4	3/8	1/2	3/4	1	1-1/4	1-1/2	2
Dimension code	.X.	0200	0300	0400	0600	1000	1200	1400	2000
Face-to-face dimension	FF	70	70	85	100	115	130	130	155
Height	H	62	62	62	65	69	89	89	89
Weight	ca. kg	0.6	0.6	0.8	0.9	1.2	3.1	3.1	4.7
Kvs-Value	m ³ /h	1.5	1.5	3.4	6.5	9.5	19.0	21.0	28.0
Cv-Value	gal/min	1.7	1.7	3.9	7.5	11.0	22.0	24.3	32.4

Dimensions in mm.

Strainer

Type 08431 - Strainer, DIN EN Flanges



Cryogenic-Strainer, PN40

Stainless steel body and bronze cap
with strainer screen mesh size 0.25 mm
"cleaned and degreased for oxygen service"

Part No. 08431.X.0002

Flanged connection acc. to DIN EN 1092-1 PN40

Available options - on request only:

- other mesh sizes for strainer screen (changed flow coefficient)
- strainer screen in bronze or monel
- sintered filter in bronze or stainless steel in various porosities
- Nominal sizes DN15, DN20 and DN150 with welded flange

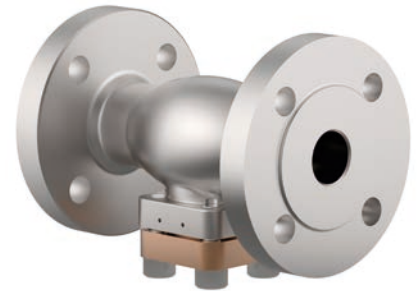

Applications:

Approved for air gases, vapours and cryogenic liquefied gases incl. LNG.
Working temperature: -196°C / -321°F (77K) up to +120°C / +248°F (393K)

Materials	DIN EN	ASTM
1 Body	1.4308	A 351 CF8
2 Strainer screen	1.4301	A 240 Grade 304
3 Bonnet gasket	PTFE	
4 Bolts	1.4301/A2	A 194 B8
5 Cap	CC493K	B 505 UNS C93200

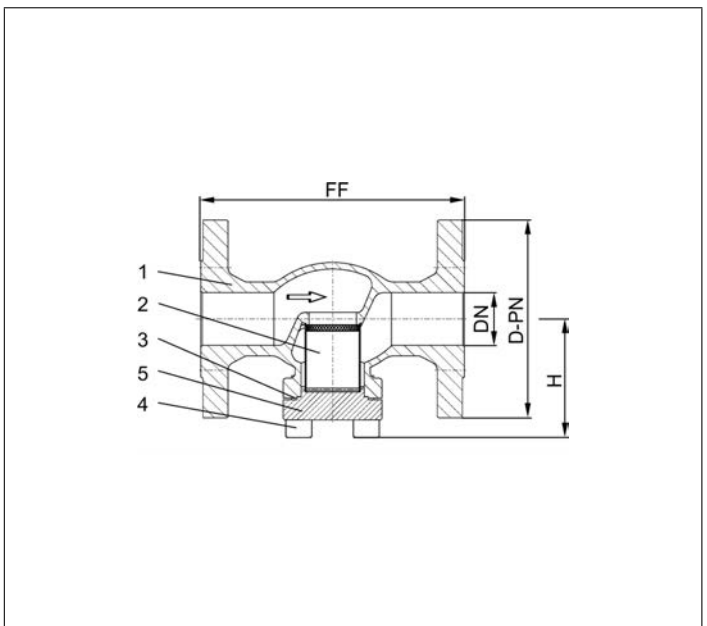

Standard marking acc. to Pressure Equipment Directive 97/23/EC (PED).



Type 08431 - Standard design	Technical data						
Nominal size	DN	25	40	50	65	80	100
Dimension code - Flange EN 1092-1 PN40	.X.	0250	0400	0500	0650	0800	1000
Flange-Ø	D-PN	115	150	165	185	200	235
Face-to-face dimension	FF	160	200	230	290	310	350
Height	H	69	89	89	125	150	166
Weight	ca. kg	4.0	8.1	10.6	17.7	23.2	36.8
Kvs-Value	m ³ /h	9.5	21.0	28.0	62.0	90.0	118.0
Cv-Value	gal/min	11.0	24.3	32.4	71.7	104.0	136.4

Dimensions in mm.

Strainer

Type 08431 - Strainer, ANSI Flanges



Cryogenic-Strainer, class 300

Stainless steel body and bronze cap
with strainer screen mesh size 0.25 mm
"cleaned and degreased for oxygen service"

Part No. 08431.X.0003

Flanged connection acc. to ANSI B16.5 class 300

Available options - on request only:

- other mesh sizes for strainer screen (changed flow coefficient)
- strainer screen in bronze or monel
- sintered filter in bronze or stainless steel in various porosities
- Nominal sizes DN15, DN20 and DN150 with welded flange



Applications:

Approved for air gases, vapours and cryogenic liquefied gases incl. LNG.
Working temperature: -196°C / -321°F (77K) up to +120°C / +248°F (393K)

Materials	DIN EN	ASTM
1 Body	1.4308	A 351 CF8
2 Strainer screen	1.4301	A 240 Grade 304
3 Bonnet gasket	PTFE	
4 Bolts	1.4301/A2	A 194 B8
5 Cap	CC493K	B 505 UNS C93200

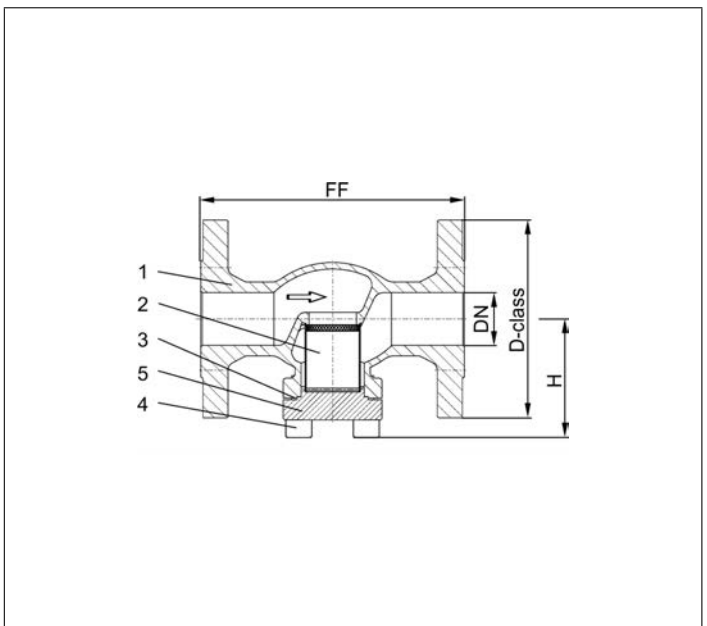

Standard marking acc. to Pressure Equipment Directive 97/23/EC (PED).



Type 08431 - Standard design	Technical data						
Nominal size	DN	25	40	50	65	80	100
Dimension code - Flange ANSI B16.5 class 300	.X.	1000	1400	2000	2400	3000	4000
Flange-Ø	D-class	123.9	155.4	165	190.5	209.5	254
Face-to-face dimension	FF	160	200	230	290	310	350
Height	H	69	89	89	125	150	166
Weight	ca. kg	4.0	8.1	10.6	17.7	23.2	36.8
Kvs-Value	m ³ /h	9.5	21.0	28.0	62.0	90.0	118.0
Cv-Value	gal/min	11.0	24.3	32.4	71.7	104.0	136.4

Dimensions in mm.

Strainer

Type 08417 - Strainer



Cryogenic-Strainer, PN50 (DN100/150=PN40)

Stainless steel body and cap
with strainer screen mesh size 0.25 mm
"cleaned and degreased for oxygen service"

Part No. 08417.X.000*

* Butt weld connection for stainless steel pipes acc. to ISO 1127 or ASTM A312

Part No. 08417.X.0004

Socket weld connection for stainless steel pipes acc. to ISO 1127 or ASTM A312

Available options - on request only:

- Welded stainless steel stubs acc. to ISO 1127 or ASTM A312 - length FF + 200mm
- other mesh sizes for strainer screen (changed flow coefficient)
- strainer screen in bronze or monel
- sintered filter in bronze or stainless steel in various porosities



Applications:

Approved for air gases, vapours and cryogenic liquefied gases incl. LNG.

Working temperature: -196°C / -321°F (77K) up to +120°C / +248°F (393K)

Materials	DIN EN	ASTM
1 Body	1.4308	A 351 CF8
2 Strainer screen	1.4301	A 240 Grade 304
3 Bonnet gasket	PTFE	
4 Bolts	1.4301/A2	A 194 B8
5 Cap	1.4301	A 276 Grade 304

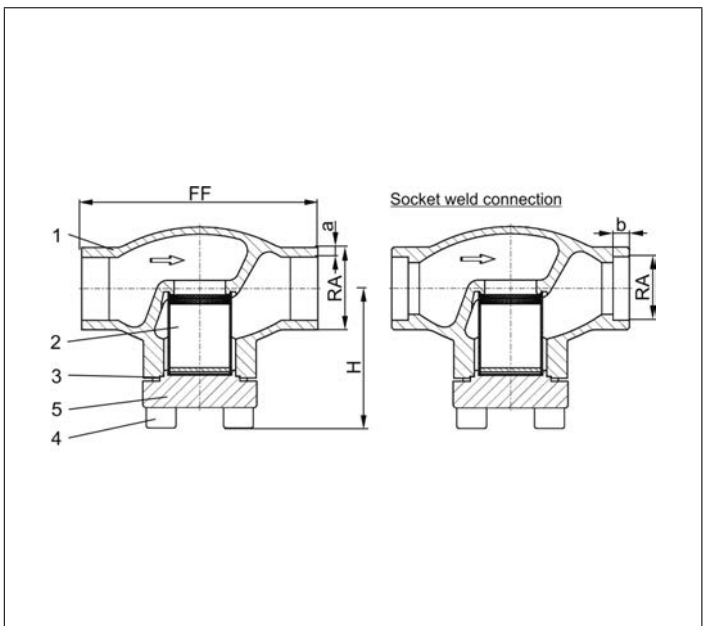

Standard marking acc. to Pressure Equipment Directive 97/23/EC (PED).



Type 08417 - Standard	Technical data													
Nominal size	DN	10	15	15	20	25	32	40	40	50	65	80	100	150
Dimension code	.X.	1012	1517	1521	2026	2533	3238	4042	4048	5060	657x	8088	0114	0168
Face-to-face dimension	FF	70	85	85	100	115	115	130	130	155	205	245	280	400
Height	H	62	62	62	65	69	76	89	89	89	125	150	166	215
Outside pipe-Ø ISO 1127	RA	12.0	17.2	21.3	26.9	33.7	38.0	42.4	48.3	60.3	76.1	88.9	114.3	168.3
Wall thickness pipe ISO 1127	a	1.0	1.6	2.0	2.0	2.0	2.0	2.0	2.0	2.0	2.6	3.2	6.0	7.1
Outside pipe-Ø ASTM A312	RA	13.72	17.15	21.34	26.67	33.40	-	42.16	48.26	60.33	73.03	88.90	114.3	168.3
Wall thickness pipe ASTM A312	a	dimensions acc. to S10 or S40												
Socket depth	b	6	10	10	13	13	-	13	13	16	16	16	20	20
Weight	ca. kg	0.6	0.75	0.8	0.9	1.2	1.8	3.1	3.1	4.7	8.9	13.6	18.0	48.0
Kvs-Value	m ³ /h	1.5	3.4	3.4	6.5	9.5	14.0	19.0	21.0	28.0	62.0	90.0	118.0	300.0
Cv-Value	gal/mi	1.7	3.9	3.9	7.5	11.0	16.2	22.0	24.3	32.4	71.7	104.0	136.4	346.8

Dimensions in mm. Compliance of tightness requirements acc. to EN 1626 for DN150 up to 20 bar differential pressure. In the range of >20-40 bar, 350-700ml (1 bar, 20°C [68°F]) are reached.

Strainer

Type 08416 - Strainer



Cryogenic-Strainer, PN50

Stainless steel body and cap
with strainer screen mesh size 0.25 mm
"cleaned and degreased for oxygen service"

Part No. 08416.X.0001

Female thread connection (G) acc. to ISO 228/1

Part No. 08416.X.0006

Female thread connection NPT acc. to ANSI B 1.20.1

Available options - on request only:

- Female thread connection (R) acc. to ISO 7-Rc
- other mesh sizes for strainer screen (changed flow coefficient)
- strainer screen in bronze or monel
- sintered filter in bronze or stainless steel in various porosities



Applications:

Approved for air gases, vapours and cryogenic liquefied gases incl. LNG.
Working temperature: -196°C / -321°F (77K) up to +120°C / +248°F (393K)

Materials	DIN EN	ASTM
1 Body	1.4308	A 351 CF8
2 Strainer screen	1.4301	A 240 Grade 304
3 Bonnet gasket	PTFE	
4 Bolts	1.4301/A2	A 194 B8
5 Cap	1.4301	A 276 Grade 304

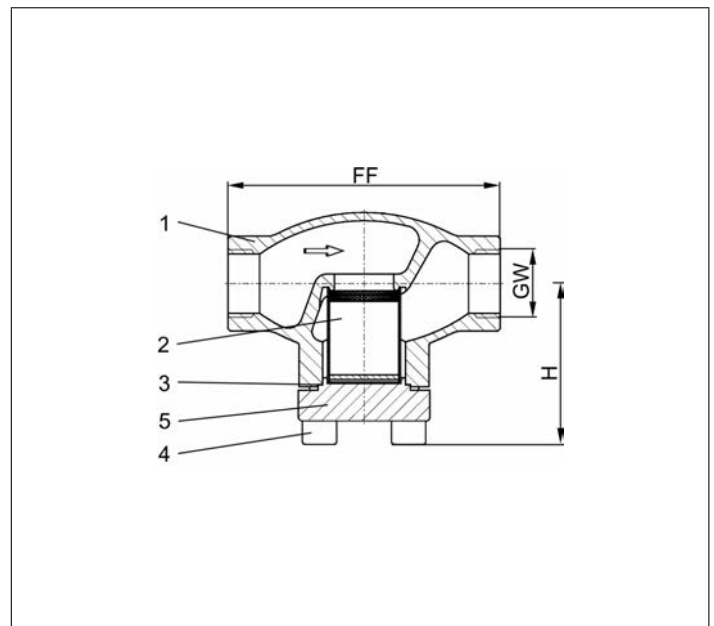

Standard marking acc. to Pressure Equipment Directive 97/23/EC (PED).



Type 08416 - Standard design	Technical data								
Nominal size	DN	10	10	15	20	25	40	40	50
Thread size	GW	1/4	3/8	1/2	3/4	1	1-1/4	1-1/2	2
Dimension code	.X.	0200	0300	0400	0600	1000	1200	1400	2000
Face-to-face dimension	FF	70	70	85	100	115	130	130	155
Height	H	62	62	62	65	69	89	89	89
Weight	ca. kg	0.6	0.6	0.8	0.9	1.2	3.1	3.1	4.7
Kvs-Value	m ³ /h	1.5	1.5	3.4	6.5	9.5	19.0	21.0	28.0
Cv-Value	gal/min	1.7	1.7	3.9	7.5	11.0	22.0	24.3	32.4

Dimensions in mm.

Strainer

Type 08432 - Strainer, DIN EN Flanges



Cryogenic-Strainer, PN40

Stainless steel body and cap
with strainer screen mesh size 0.25 mm
"cleaned and degreased for oxygen service"

Part No. 08432.X.0002

Flanged connection acc. to DIN EN 1092-1 PN40

Available options - on request only:

- other mesh sizes for strainer screen (changed flow coefficient)
- strainer screen in bronze or monel
- sintered filter in bronze or stainless steel in various porosities
- Nominal sizes DN15, DN20 and DN150 with welded flange



Applications:

Approved for air gases, vapours and cryogenic liquefied gases incl. LNG.
Working temperature: -196°C / -321°F (77K) up to +120°C / +248°F (393K)

Materials	DIN EN	ASTM
1 Body	1.4308	A 351 CF8
2 Strainer screen	1.4301	A 240 Grade 304
3 Bonnet gasket	PTFE	
4 Bolts	1.4301/A2	A 194 B8
5 Cap	1.4301	A 276 Grade 304

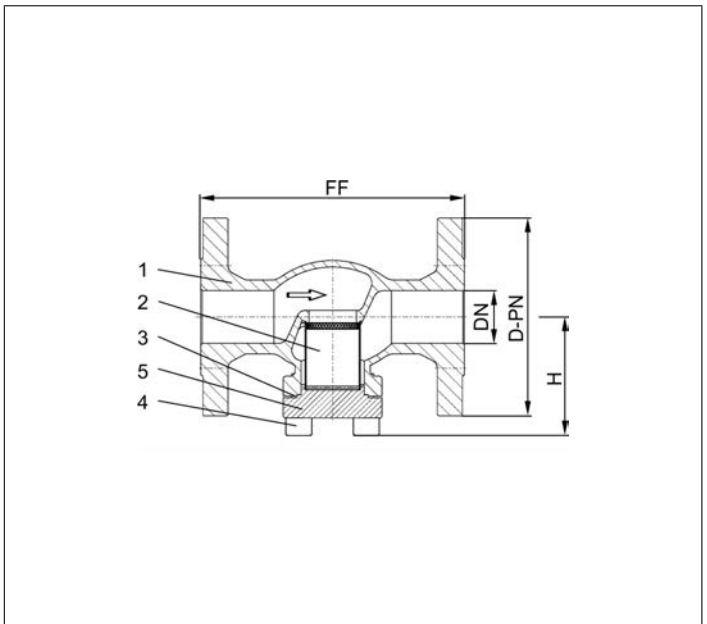

Standard marking acc. to Pressure Equipment Directive 97/23/EC (PED).



Type 08432 - Standard design	Technical data						
Nominal size	DN	25	40	50	65	80	100
Dimension code - Flange EN 1092-1 PN40	.X.	0250	0400	0500	0650	0800	1000
Flange-Ø	D-PN	115	150	165	185	200	235
Face-to-face dimension	FF	160	200	230	290	310	350
Height	H	69	89	89	125	150	166
Weight	ca. kg	4.0	5.6	10.6	17.7	23.2	36.8
Kvs-Value	m ³ /h	9.5	21.0	28.0	62.0	90.0	118.0
Cv-Value	gal/min	11.0	24.3	32.4	71.7	104.0	136.4

Dimensions in mm.

Strainer

Type 08432 - Strainer, ANSI Flanges



Cryogenic-Strainer, class 300

Stainless steel body and cap
with strainer screen mesh size 0.25 mm
"cleaned and degreased for oxygen service"

Part No. 08432.X.0003

Flanged connection acc. to ANSI B16.5 class 300

Available options - on request only:

- other mesh sizes for strainer screen (changed flow coefficient)
- strainer screen in bronze or monel
- sintered filter in bronze or stainless steel in various porosities
- Nominal sizes DN15, DN20 and DN150 with welded flange

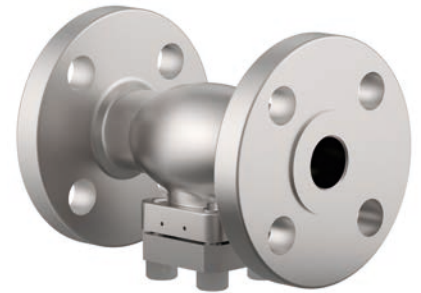

Applications:

Approved for air gases, vapours and cryogenic liquefied gases incl. LNG.
Working temperature: -196°C / -321°F (77K) up to +120°C / +248°F (393K)

Materials	DIN EN	ASTM
1 Body	1.4308	A 351 CF8
2 Strainer screen	1.4301	A 240 Grade 304
3 Bonnet gasket	PTFE	
4 Bolts	1.4301/A2	A 194 B8
5 Cap	1.4301	A 276 Grade 304

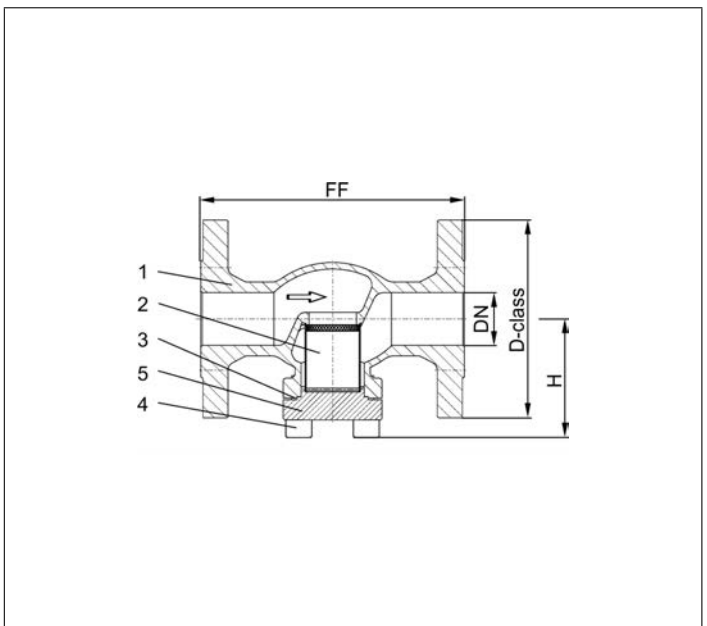

Standard marking acc. to Pressure Equipment Directive 97/23/EC (PED).



Type 08432 - Standard design	Technical data						
Nominal size	DN	25	40	50	65	80	100
Dimension code - Flange ANSI B16.5 class 300	.X.	1000	1400	2000	2400	3000	4000
Flange-Ø	D-class	123.9	155.4	165	190.5	209.5	254
Face-to-face dimension	FF	160	200	230	290	310	350
Height	H	69	89	89	125	150	166
Weight	ca. kg	4.0	5.6	10.6	17.7	23.2	36.8
Kvs-Value	m ³ /h	9.5	21.0	28.0	62.0	90.0	118.0
Cv-Value	gal/min	11.0	24.3	32.4	71.7	104.0	136.4

Dimensions in mm.

Spare Parts Strainer

Type 30800, Type 30801 - Strainer screen, Filter



for Cryogenic-Strainer

"cleaned and degreased for oxygen service"

Part No. 30800.X.0250A2

Stainless steel strainer screen (1.4301 / A 240 Grade 304) with a mesh size of 0.25 mm or rather 56 mesh

Part No. 30800.X.0100A2

Stainless steel strainer screen (1.4301 / A 240 Grade 304) with a mesh size of 0.10 mm or rather 140 mesh

Part No. 30800.X.0250A4

Stainless steel strainer screen (1.4404 / A 276 Grade 316L) with a mesh size of 0.25 mm or rather 56 mesh

Part No. 30800.X.0250M

Monel strainer screen (2.4360 / SB 164 - N04400) with a mesh size of 0.25 mm or rather 56 mesh

Part No. 30800.X.0150M

Monel strainer screen (2.4360 / SB 164 - N04400) with a mesh size of 0.15 mm or rather 100 mesh

Part No. 30801.X.0100B

Sintered bronze Filter (CW483K / B 427 C 90800) with a porosity of 100 μ

Part No. 30801.X.0030B

Sintered bronze Filter (CW483K / B 427 C 90800) with a porosity of 30 μ



suitable for:

Type	Nominal size
08412, 08413, 08415, 08416, 08716	DN10 - DN50
08414, 08417	DN10 - DN200
08431, 08432	DN25 - DN100
08717	DN10 - DN100

consisting of:

- 1x Strainer screen or Filter (materials see above)
- 1x Spring ring (1.4568)
- 1x Bonnet gasket (PTFE)

Available options - on request only:

- Further mesh sizes / porosities

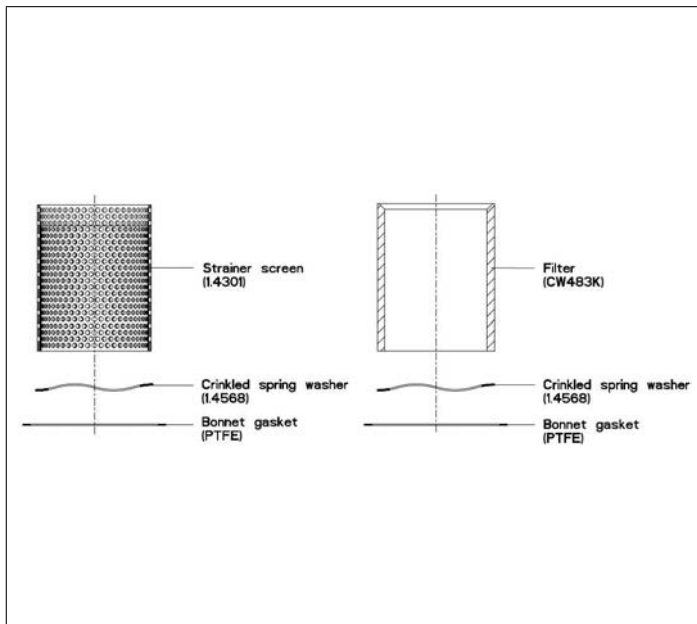

Type 30800, 30801	Technical Data												
Nominal size	DN	10	15	20	25	32	40	50	65	80	100	150	200
Dimension code	.X.	0100	0150	0200	0250	0320	0400	0500	0650	0800	1000	1500	2000
Weight	ca. kg	0.03	0.03	0.04	0.05	0.07	0.08	0.13	0.18	0.24	0.32	0.68	0.92
Kvs - Value MS 0.25	m ³ /h	2.8	3.6	6.4	9.0	14.5	21.0	30.0	56.0	85.0	115.0	o.r.	o.r.
Cv - Value MS 0.25	gal/min	3.2	4.1	7.4	10.4	16.8	24.3	34.8	64.9	98.6	133.4	o.r.	o.r.
Kvs - Value MS 0.15	m ³ /h	2.8	3.6	6.4	9.0	o.r.	21.0	29.5	o.r.	o.r.	o.r.	o.r.	o.r.
Cv - Value MS 0.15	gal/min	3.2	4.1	7.4	10.4	o.r.	24.3	34.2	o.r.	o.r.	o.r.	o.r.	o.r.
Kvs - Value MS 0.10	m ³ /h	o.r.*	o.r.	o.r.	9.0	14.0	19.0	o.r.	o.r.	o.r.	o.r.	o.r.	o.r.
Cv - Value MS 0.10	gal/min	o.r.	o.r.	o.r.	10.4	16.2	22.0	o.r.	o.r.	o.r.	o.r.	o.r.	o.r.
Kvs - Value 100 μ	m ³ /h	2.8	3.3	6.0	7.0	o.r.	13.5	18.5	o.r.	o.r.	o.r.	o.r.	o.r.
Cv - Value 100 μ	gal/min	3.2	3.8	6.9	8.1	o.r.	15.6	21.4	o.r.	o.r.	o.r.	o.r.	o.r.
Kvs - Value 30 μ	m ³ /h	o.r.	1.7	3.5	4.0	o.r.	6.5	11.0	o.r.	o.r.	o.r.	o.r.	o.r.
Cv - Value 30 μ	gal/min	o.r.	1.9	4.0	4.6	o.r.	7.5	12.7	o.r.	o.r.	o.r.	o.r.	o.r.

*o.r. = on request. Dimensions in mm.

Safety Valves

Type 06001 - gastight



Cryogenic Safety Valves, angle type, brass, PN63, type tested TÜV-SV.1048. S/G/L

Standard Safety Valve,
complete with carbon filled PTFE valve seal, closed bonnet, gastight
Outlet: female thread Rc 3/8 acc. to ISO 7/1
"cleaned and degreased for oxygen service"

Part No. 06001.X.0000

Inlet: male thread type R (BSPT) acc. to ISO 7/1

Part No. 06001.X.2000

Inlet: male thread type G (BSPP) acc. to ISO 228/1

Part No. 06001.X.5000

Inlet: male thread NPT acc. to ANSI B 1.20.1

Available options - on request only:

- with installed elbow at the outlet



Applications:

Provided as safety device for protection against thermal expansion in pipeworks and parts of facilities.
Approved for air gases, vapours and cryogenic liquefied gases incl. LNG.
Working temperature: -196°C / -321°F (77K) up to +65°C / +149°F (338K), suitable for horizontal installation

Materials	DIN EN	ASME/ASTM
1 Body	CW610N	B 111 UNS C36500
2 Disc	PTFE / Carbon filled (25%)	
3 Guide plate	CW614N	B 283 UNS C38500
4 Stem	CW614N	B 283 UNS C38500
5 Spring	1.4571	A 313 Grade 316Ti
6 Bonnet	CW614N	B 283 UNS C38500
7 Spring clamp	CW614N	B 283 UNS C38500
8 Thread ring	CW614N	B 283 UNS C38500
9 Cap	CW614N	B 283 UNS C38500

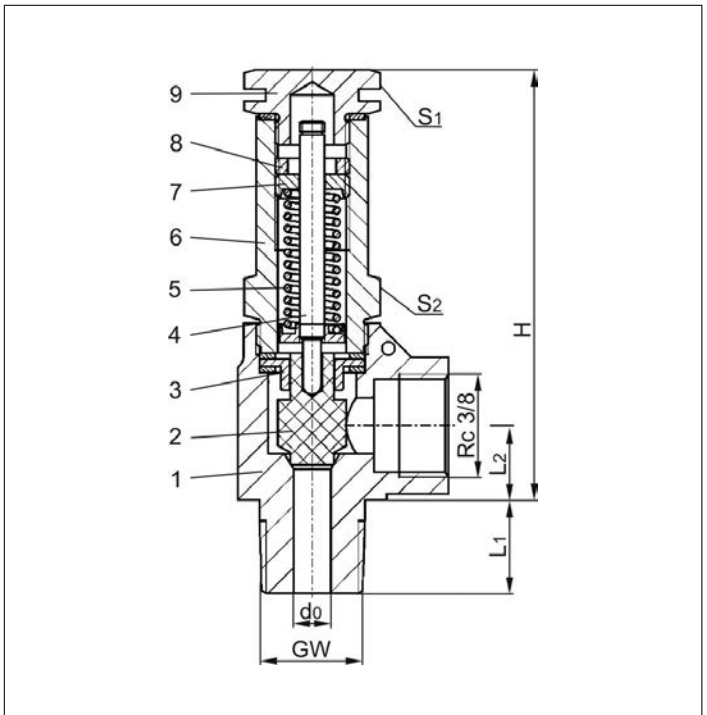

Essential: Valves are delivered at a set pressure, therefore when ordering please confirm set pressure, medium and temperature.

Standard marking acc. to Pressure Equipment Directive 97/23/EC (PED).



Type 06001	Technical data			
Nominal size	GW	1/4	3/8	1/2
Orifice	d ₀	6.0	6.0	6.0
Dimension code	.X.	0200	0300	0400
Set pressure range	bar	5.0-55.0	5.0-55.0	5.0-55.0
Height	H	70	70	70
Length	L ₁	13	15	17
Length	L ₂	13	13	13
Wrench size across flats	S ₁	19	19	19
Wrench size across flats	S ₂	19	19	19
Weight	ca. kg	0.18	0.195	0.21
Coefficient of discharge	α _w	0.09	0.09	0.09

Dimensions in mm.

Safety Valves

Type 06001 - gastight



Discharge capacities

Calculation of flow rate acc. to AD2000-Merkblatt A2 / DIN EN ISO 4126-1

Medium:

Air in m³/h at 0°C and 1013.25 mbar

Water in kg/h

The capacity indicated below is for a fully opened valve.

d_0 - orifice

A_0 - flow area

Set pressure in bar (g)	GW	1/4, 3/8 & 1/2	1/4, 3/8 & 1/2
	d_0 (mm)	6.0	6.0
	A_0 (mm ²)	28.3	28.3
	Medium	Air	Water
5.0		11.3	303
6.0		13.3	332
7.0		15.2	359
8.0		17.1	384
9.0		19.1	407
10.0		21.0	429
12.0		24.9	470
14.0		28.7	508
16.0		32.6	543
18.0		36.4	576
20.0		40.7	607
22.0		44.5	637
24.0		48.4	665
26.0		52.3	692
28.0		56.2	719
30.0		60.6	744
32.0		64.6	768
34.0		68.5	792
36.0		72.4	815
38.0		76.3	837
40.0		80.9	859
42.0		84.9	880
44.0		88.9	901
46.0		92.8	921
48.0		96.8	941
50.0		101.6	960
52.0		105.6	979
54.0		109.6	998
55.0		111.6	1007

Safety Valves

Type 06002, Type 06006



Cryogenic Safety Valves, angle type, brass, PN63, type tested TÜV-SV.1048. S/G

Standard safety valve, with carbon filled PTFE valve seal

Outlet: female thread Rc 3/8 acc. to ISO 7/1, "cleaned and degreased for oxygen service"

Type 06002: Closed bonnet drainage hole in the locking screw

Type 06006: drainage hole in bonnet

Part No. 06002.X.0000

Part No. 06006.X.0000 (with lifting device)

Inlet: male thread type R (BSPT) acc. to ISO 7/1

Part No. 06002.X.2000

Part No. 06006.X.2000 (with lifting device)

Inlet: male thread type G (BSPP) acc. to ISO 228/1

Part No. 06002.X.5000

Part No. 06006.X.5000 (with lifting device)

Inlet: male thread NPT acc. to ANSI B 1.20.1

Available options - on request only:

- with installed elbow at the outlet



Applications:

Provided as safety device for protection against thermal expansion in pipeworks and parts of facilities.

Approved for air gases, vapours and cryogenic liquefied gases incl. LNG.

Working temperature: -196°C / -321°F (77K) up to +150°C / +302°F (423K), suitable for horizontal installation

Materials	DIN EN	ASME/ASTM
1 Body	CW617N	EN12165 CW617N Code Case 1750
2 Valve seal	PTFE / Carbon filled (25%)	
3 Disc	CW452K	B 103 UNS C51900
4 Guide plate	CC493K	SB 505 C93200
5 Stem	CW614N	EN12164 CW614N Code Case 1750
6 Spring	1.4571	A 313 Grade 316Ti
7 Bonnet	CW614N	EN12164 CW614N Code Case 1750
8 Spring clamp	CW614N	EN12164 CW614N Code Case 1750
9 Thread ring	CW614N	EN12164 CW614N Code Case 1750
10 Cap	CW614N	EN12164 CW614N Code Case 1750
11 Lifting device	CW614N	EN12164 CW614N Code Case 1750
12 Closing cap	CW507L	B 30 UNS C27000

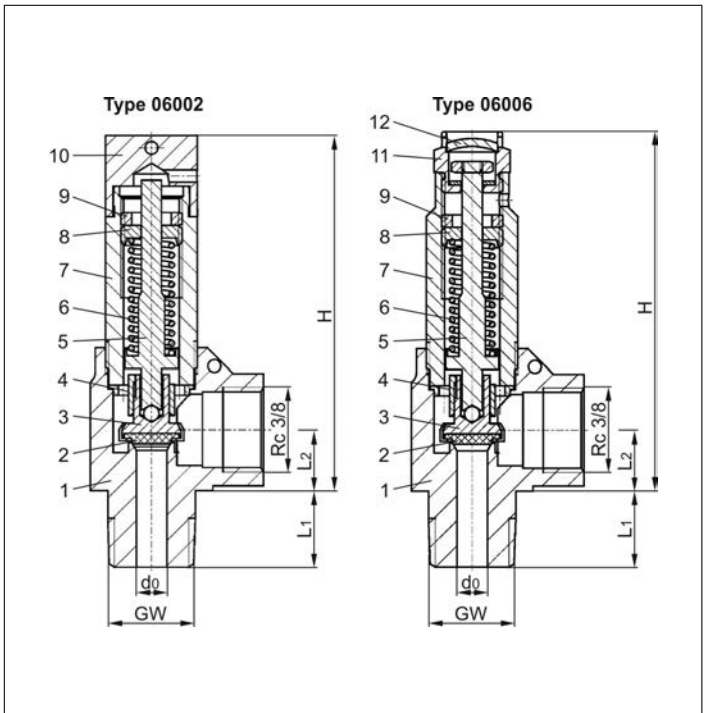

Essential: Valves are delivered at a set pressure, therefore when ordering please confirm set pressure, medium and temperature.

Standard marking acc. to Pressure Equipment Directive 97/23/EC (PED).



Technical data	Type 06002			Type 06006			
	GW	1/4	3/8	1/2	1/4	3/8	1/2
Nominal size	GW	1/4	3/8	1/2	1/4	3/8	1/2
Orifice	d ₀	6.0	6.0	6.0	6.0	6.0	6.0
Dimension code	.X.	0200	0300	0400	0200	0300	0400
Set pressure range	bar	1.0-55.0	1.0-55.0	1.0-55.0	1.0-55.0	1.0-55.0	1.0-55.0
Height	H	70	70	70	72	72	72
Length	L ₁	13	15	17	13	15	17
Length	L ₂	13	13	13	13	13	13
Weight	ca. kg	0.185	0.20	0.22	0.18	0.195	0.21
Coeff. of discharge from 3.0 bar	α _w	0.42	0.42	0.42	0.42	0.42	0.42

Dimensions in mm.

Safety Valves

Type 06002, Type 06006



Discharge capacities

Calculation of flow rate acc. to AD2000-Merkblatt A2 / DIN EN ISO 4126-1

Medium:

Air in m³/h at 0°C and 1013.25 mbar

The capacity indicated below is for a fully opened valve.

d₀ - orifice

A₀ - flow area

Set pressure in bar (g)	GW	1/4, 3/8 & 1/2
	d ₀ (mm)	6.0
	A ₀ (mm ²)	28.3
	Medium	Air
1.0		15.5
2.0		26.0
3.0		35.0
4.0		43.9
5.0		52.9
6.0		61.8
7.0		70.8
8.0		80.0
9.0		88.9
10.0		98.1
12.0		116.1
14.0		134.0
16.0		152.0
18.0		169.9
20.0		189.7
22.0		207.8
24.0		226.0
26.0		244.1
28.0		262.2
30.0		283.0
32.0		301.3
34.0		319.6
36.0		337.9
38.0		356.2
40.0		377.8
42.0		396.2
44.0		414.7
46.0		433.2
48.0		451.6
50.0		474.1
52.0		492.7
54.0		511.3
55.0		520.6

Safety Valves

Type 06002 - gastight



Cryogenic Safety Valves, angle type, brass, PN63, type tested TÜV-SV.1048. S/G

Standard Safety Valve,
gastight, closed bonnet
with carbon filled PTFE valve seal
Outlet: female thread Rc 3/8 acc. to ISO 7/1
"cleaned and degreased for oxygen service"

Part No. 06002.X.0020

Inlet: male thread type R (BSPT) acc. to ISO 7/1

Part No. 06002.X.2020

Inlet: male thread type G (BSPP) acc. to ISO 228/1

Part No. 06002.X.5020

Inlet: male thread NPT acc. to ANSI B 1.20.1

Available options - on request only:

- with installed elbow at the outlet



Applications:

Provided as safety device for protection against thermal expansion in pipeworks and parts of facilities.
Approved for air gases, vapours and cryogenic liquefied gases incl. LNG.
Working temperature: -196°C / -321°F (77K) up to +150°C / +302°F (423K), suitable for horizontal installation

Materials	DIN EN	ASME/ASTM
1 Body	CW617N	EN12165 CW617N Code Case 1750
2 Valve seal	PTFE / Carbon filled (25%)	
3 Disc	CW452K	B 103 UNS C51900
4 Guide plate	CC493K	SB 505 C93200
5 Stem	CW614N	EN12164 CW614N Code Case 1750
6 Spring	1.4571	A 313 Grade 316Ti
7 Bonnet	CW614N	EN12164 CW614N Code Case 1750
8 Spring clamp	CW614N	EN12164 CW614N Code Case 1750
9 Thread ring	CW614N	EN12164 CW614N Code Case 1750
10 Cap	CW614N	EN12164 CW614N Code Case 1750

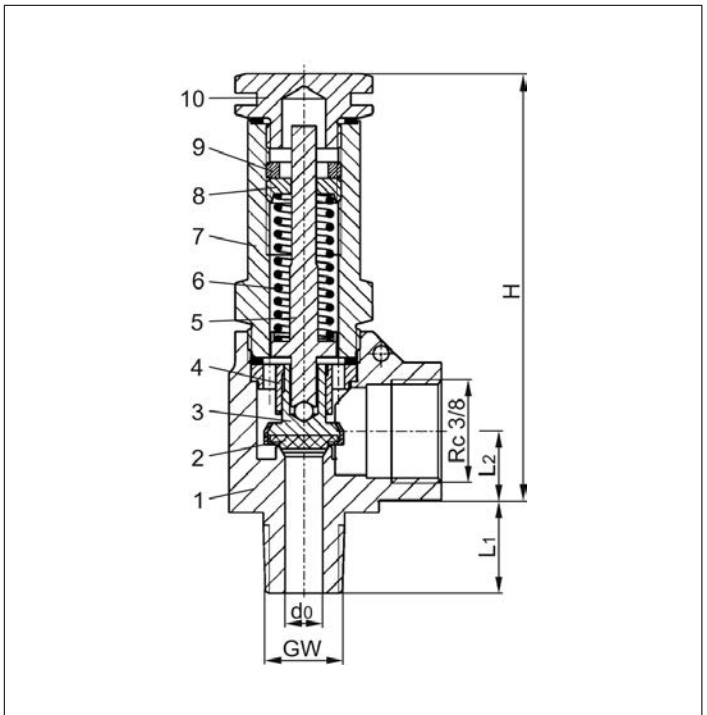

Essential: Valves are delivered at a set pressure, therefore when ordering please confirm set pressure, medium and temperature.

Standard marking acc. to Pressure Equipment Directive 97/23/EC (PED).



Type 06002	Technical data			
Nominal size	GW	1/4	3/8	1/2
Orifice	d ₀	6.0	6.0	6.0
Dimension code	.X.	0200	0300	0400
Set pressure range	bar	1.0-55.0	1.0-55.0	1.0-55.0
Height	H	70	70	70
Length	L ₁	13	15	17
Length	L ₂	13	13	13
Weight	ca. kg	0.18	0.20	0.22
Coefficient of discharge	α _w	0.34	0.34	0.34

Dimensions in mm.

Safety Valves

Type 06002 - gastight



Discharge capacities

Calculation of flow rate acc. to AD2000-Merkblatt A2 / DIN EN ISO 4126-1

Medium:

Air in m³/h at 0°C and 1013.25 mbar

The capacity indicated below is for a fully opened valve.

d₀ - orifice

A₀ - flow area

Set pressure in bar (g)	GW	1/4, 3/8 & 1/2
	d ₀ (mm)	6.0
	A ₀ (mm ²)	28.3
	Medium	Air
1.0		12.0
2.0		20.0
3.0		28.0
4.0		35.0
5.0		42.0
6.0		50.0
7.0		57.0
8.0		64.0
9.0		71.0
10.0		79.0
12.0		93.0
14.0		108.0
16.0		123.0
18.0		137.0
20.0		153.0
22.0		168.0
24.0		182.0
26.0		197.0
28.0		212.0
30.0		229.0
32.0		243.0
34.0		258.0
36.0		273.0
38.0		288.0
40.0		305.0
42.0		320.0
44.0		335.0
46.0		350.0
48.0		365.0
50.0		383.0
52.0		398.0
54.0		413.0
55.0		421.0

Safety Valves

Type 06011 - gastight



Cryogenic Safety Valves, angle type, stainless steel, PN63, type tested TÜV-SV.1048. S/G/L

Standard safety valve,
complete with carbon filled PTFE valve seal, closed bonnet, gastight
Outlet: female thread Rc 3/8 acc. to ISO 7/1
"cleaned and degreased for oxygen service"

Part No. 06011.X.0000

Inlet: male thread type R (BSPT) acc. to ISO 7/1

Part No. 06011.X.2000

Inlet: male thread type G (BSPP) acc. to ISO 228/1

Part No. 06011.X.5000

Inlet: male thread NPT acc. to ANSI B 1.20.1

Available options - on request only:

- with installed elbow at the outlet



Applications:

Provided as safety device for protection against thermal expansion in pipeworks and parts of facilities.

Approved for air gases, vapours and cryogenic liquefied gases incl. LNG.

Working temperature: -196°C / -321°F (77K) up to +65°C / +149°F (338K), suitable for horizontal installation

Materials	DIN EN	ASME/ASTM
1 Body	1.4408	A 351 CF8M
2 Disc	PTFE / Carbon filled (25%)	
3 Guide plate	1.4301	A 276 Grade 304
4 Stem	1.4301	A 276 Grade 304
5 Spring	1.4571	A 313 Grade 316Ti
6 Bonnet	1.4301	A 276 Grade 304
7 Spring clamp	1.4305	A 276 Grade 303
8 Thread ring	1.4305	A 276 Grade 303
9 Cap	1.4301	A 276 Grade 304

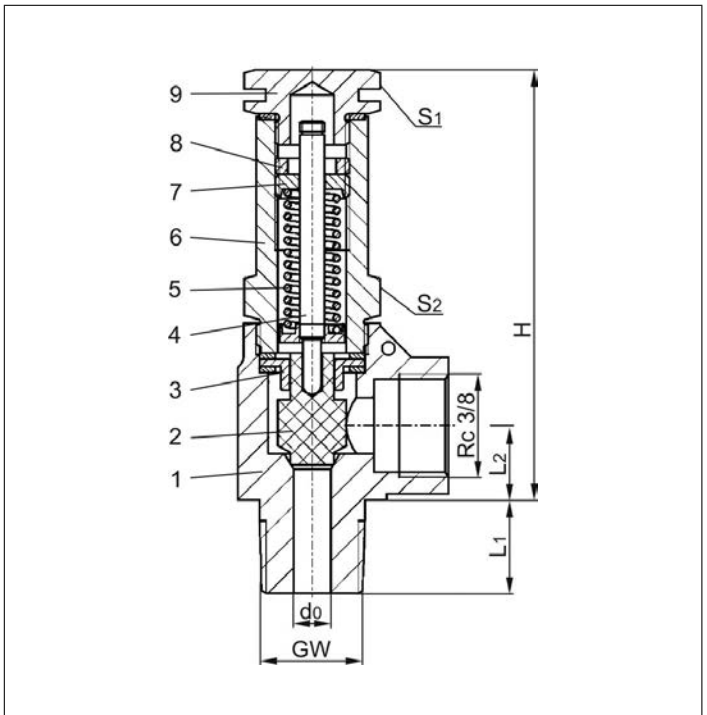

Essential: Valves are delivered at a set pressure, therefore when ordering please confirm set pressure, medium and temperature.

Standard marking acc. to Pressure Equipment Directive 97/23/EC (PED).



Type 06011	Technical data			
Nominal size	GW	1/4	3/8	1/2
Orifice	d ₀	6.0	6.0	6.0
Dimension code	.X.	0200	0300	0400
Set pressure range	bar	5.0-55.0	5.0-55.0	5.0-55.0
Height	H	70	70	70
Length	L ₁	13	15	17
Length	L ₂	13	13	13
Wrench size across flats	S ₁	19	19	19
Wrench size across flats	S ₂	19	19	19
Weight	ca. kg	0.18	0.195	0.21
Coefficient of discharge	α _w	0.09	0.09	0.09

Dimensions in mm.

Safety Valves

Type 06011 - gastight



Discharge capacities

Calculation of flow rate acc. to AD2000-Merkblatt A2 / DIN EN ISO 4126-1

Medium:

Air in m³/h at 0°C and 1013.25 mbar

Water in kg/h

The capacity indicated below is for a fully opened valve.

d_0 - orifice

A_0 - flow area

Set pressure in bar (g)	GW	1/4. 3/8 & 1/2	1/4. 3/8 & 1/2
	d_0 (mm)	6.0	6.0
	A_0 (mm ²)	28.3	28.3
	Medium	Air	Water
5.0		11.3	303
6.0		13.3	332
7.0		15.2	359
8.0		17.1	384
9.0		19.1	407
10.0		21.0	429
12.0		24.9	470
14.0		28.7	508
16.0		32.6	543
18.0		36.4	576
20.0		40.7	607
22.0		44.5	637
24.0		48.4	665
26.0		52.3	692
28.0		56.2	719
30.0		60.6	744
32.0		64.6	768
34.0		68.5	792
36.0		72.4	815
38.0		76.3	837
40.0		80.9	859
42.0		84.9	880
44.0		88.9	901
46.0		92.8	921
48.0		96.8	941
50.0		101.6	960
52.0		105.6	979
54.0		109.6	998
55.0		111.6	1007

Safety Valves

Type 06012, Type 06016



Cryogenic Safety Valves, angle type, stainless steel, PN63, type tested TÜV-SV.1048. S/G

Standard safety valve, with carbon filled PTFE valve seal, open bonnet

Outlet: female thread Rc 3/8 acc. to ISO 7/1, "cleaned and degreased for oxygen service"

Type 06012: Closed bonnet drainage hole in the locking screw

Type 06016: drainage hole in the bonnet

Part No. 06012.X.0000:

Part No. 06016.X.0000 (with lifting device)

Inlet: male thread type R (BSPT) acc. to ISO 7/1

Part No. 06012.X.2000

Part No. 06016.X.2000 (with lifting device)

Inlet: male thread type G (BSPP) acc. to ISO 228/1

Part No. 06012.X.5000

Part No. 06016.X.5000 (with lifting device)

Inlet: male thread NPT acc. to ANSI B 1.20.1

Available options - on request only:

- with installed elbow at the outlet



Applications:

Provided as safety device for protection against thermal expansion in pipeworks and parts of facilities.

Approved for air gases, vapours and cryogenic liquefied gases incl. LNG.

Working temperature: -196°C / -321°F (77K) up to +150°C / +302°F (423K), suitable for horizontal installation

Materials	DIN EN	ASME/ASTM
1 Body	1.4408	A 351 CF8M
2 Valve seal	PTFE / Carbon filled (25%)	
3 Disc	1.4301	A 276 Grade 304
4 Guide plate	1.4301	A 276 Grade 304
5 Stem	1.4301	A 276 Grade 304
6 Spring	1.4571	A 313 Grade 316Ti
7 Bonnet	1.4301	A 276 Grade 304
8 Spring clamp	1.4305	A 276 Grade 303
9 Thread ring	1.4305	A 276 Grade 303
10 Cap	1.4301	A 276 Grade 304
11 Lifting device	1.4305	A 276 Grade 303
12 Closing cap	1.4305	A 276 Grade 303

Essential: Valves are delivered at a set pressure, therefore when ordering please confirm set pressure, medium and temperature.

Standard marking acc. to Pressure Equipment Directive 97/23/EC (PED).

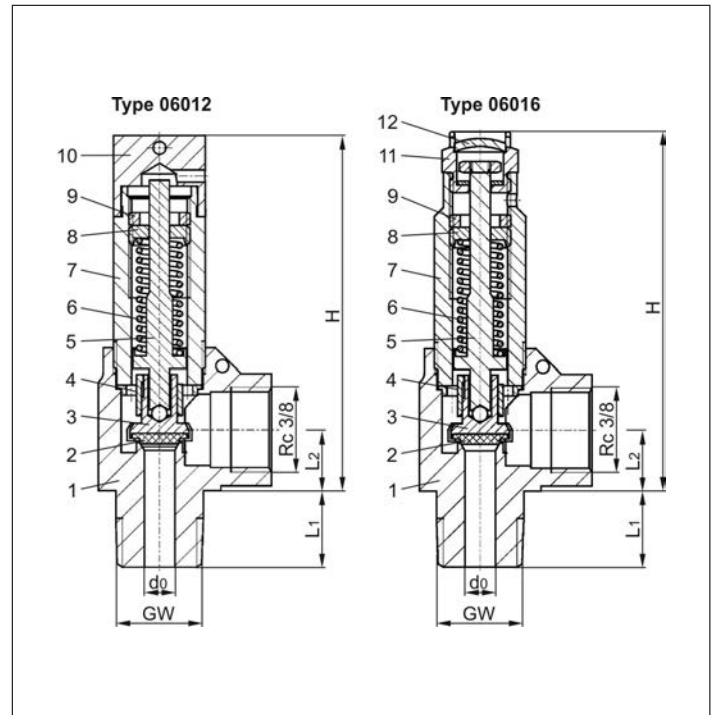

Technical data	Type 06012			Type 06016			
	GW	1/4	3/8	1/2	1/4	3/8	1/2
Nominal size	d ₀	6.0	6.0	6.0	6.0	6.0	6.0
Orifice	.X.	0200	0300	0400	0200	0300	0400
Dimension code	bar	1.0-55.0	1.0-55.0	1.0-55.0	1.0-55.0	1.0-55.0	1.0-55.0
Set pressure range	H	70	70	70	72	72	72
Height	L ₁	13	15	17	13	15	17
Length	L ₂	13	13	13	13	13	13
Length	ca. kg	0.185	0.20	0.22	0.18	0.195	0.21
Weight	α _w	0.42	0.42	0.42	0.42	0.42	0.42
Coeff. of discharge from 3.0 bar							

Dimensions in mm.

Safety Valves

Type 06012, Type 06016



Discharge capacities

Calculation of flow rate acc. to AD2000-Merkblatt A2 / DIN EN ISO 4126-1

Medium:

Air in m³/h at 0°C and 1013.25 mbar

The capacity indicated below is for a fully opened valve.

d₀ - orifice

A₀ - flow area

Set pressure in bar (g)	GW	1/4. 3/8 & 1/2
	d ₀ (mm)	6.0
	A ₀ (mm ²)	28.3
	Medium	Air
1.0		15.5
2.0		26.0
3.0		35.0
4.0		43.9
5.0		52.9
6.0		61.8
7.0		70.8
8.0		80.0
9.0		88.9
10.0		98.1
12.0		116.1
14.0		134.0
16.0		152.0
18.0		169.9
20.0		189.7
22.0		207.8
24.0		226.0
26.0		244.1
28.0		262.2
30.0		283.0
32.0		301.3
34.0		319.6
36.0		337.9
38.0		356.2
40.0		377.8
42.0		396.2
44.0		414.7
46.0		433.2
48.0		451.6
50.0		474.1
52.0		492.7
54.0		511.3
55.0		520.6

Safety Valves

Type 06012 - gastight



Cryogenic Safety Valves, angle type, stainless steel, PN63, type tested TÜV-SV.1048. S/G

Standard Safety Valve,
gastight, closed bonnet
with carbon filled PTFE valve seal

Outlet: female thread Rc 3/8 acc. to ISO 7/1
"cleaned and degreased for oxygen service"

Part No. 06012.X.0020

Inlet: male thread type R (BSPT) acc. to ISO 7/1

Part No. 06012.X.2020

Inlet: male thread type G (BSPP) acc. to ISO 228/1

Part No. 06012.X.5020

Inlet: male thread NPT acc. to ANSI B 1.20.1

Available options - on request only:

- with installed elbow at the outlet



Applications:

Provided as safety device for protection against thermal expansion in pipeworks and parts of facilities.

Approved for air gases, vapours and cryogenic liquefied gases incl. LNG.

Working temperature: -196°C / -321°F (77K) up to +150°C / +302°F (423K), suitable for horizontal installation

Materials	DIN EN	ASME/ASTM
1 Body	1.4408	A 351 CF8M
2 Valve seal	PTFE / Carbon filled (25%)	
3 Disc	1.4301	A 276 Grade 304
4 Guide plate	1.4301	A 276 Grade 304
5 Stem	1.4301	A 276 Grade 304
6 Spring	1.4571	A 313 Grade 316Ti
7 Bonnet	1.4301	A 276 Grade 304
8 Spring clamp	1.4305	A 276 Grade 303
9 Thread ring	1.4305	A 276 Grade 303
10 Cap	1.4301	A 276 Grade 304

Essential: Valves are delivered at a set pressure, therefore when ordering please confirm set pressure, medium and temperature.

Standard marking acc. to Pressure Equipment Directive 97/23/EC (PED).

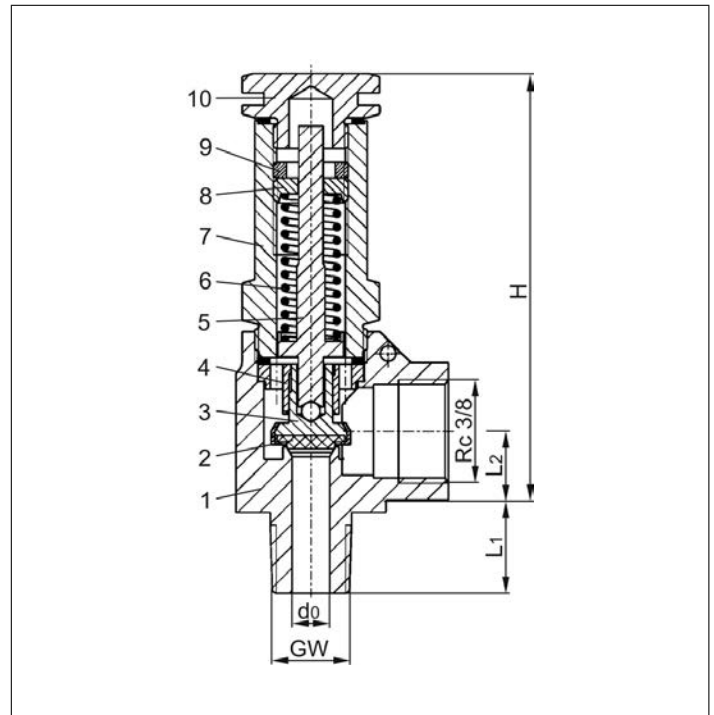

Type 06002	Technical data			
Nominal size	GW	1/4	3/8	1/2
Orifice	d ₀	6.0	6.0	6.0
Dimension code	.X.	0200	0300	0400
Set pressure range	bar	1.0-55.0	1.0-55.0	1.0-55.0
Height	H	70	70	70
Length	L ₁	13	15	17
Length	L ₂	13	13	13
Weight	ca. kg	0.18	0.20	0.22
Coefficient of discharge	α _w	0.34	0.34	0.34

Dimensions in mm.

Safety Valves

Type 06012 - gastight



Discharge capacities

Calculation of flow rate acc. to AD2000-Merkblatt A2 / DIN EN ISO 4126-1

Medium:

Air in m³/h at 0°C and 1013.25 mbar

The capacity indicated below is for a fully opened valve.

d₀ - orifice

A₀ - flow area

Set pressure in bar (g)	GW	1/4, 3/8 & 1/2
	d ₀ (mm)	6.0
	A ₀ (mm ²)	28.3
	Medium	Air
1.0		12.0
2.0		20.0
3.0		28.0
4.0		35.0
5.0		42.0
6.0		50.0
7.0		57.0
8.0		64.0
9.0		71.0
10.0		79.0
12.0		93.0
14.0		108.0
16.0		123.0
18.0		137.0
20.0		153.0
22.0		168.0
24.0		182.0
26.0		197.0
28.0		212.0
30.0		229.0
32.0		243.0
34.0		258.0
36.0		273.0
38.0		288.0
40.0		305.0
42.0		320.0
44.0		335.0
46.0		350.0
48.0		365.0
50.0		383.0
52.0		398.0
54.0		413.0
55.0		421.0

Safety Valves

Type 06472



Cryogenic Safety Valves, angle type, bronze, PN40, type tested TÜV-SV.836. S/G

Standard safety valve,

metal to metal seated, closed bonnet

Outlet: female thread type G 1/2 acc. to ISO 228/1

"cleaned and degreased for oxygen service"

Part No. 06472.X.0000

Part No. 06472.0600.9000

Inlet: male thread type G (BSPP) acc. to ISO 228/1

Part No. 06472.X.5000

Inlet: male thread NPT acc. to ANSI B 1.20.1

Part No. 06472.0600.0000

Inlet: union type braze fitting for pipe outside diameter 12 mm

Available options - on request only:

- external parts nickel plated
- with installed elbow at the outlet



Applications:

Provided as safety device for protection against excessive pressure in stationary and moveable gas cylinders and pressure vessels. Approved for air gases, vapours and cryogenic liquefied gases incl. LNG.

Working temperature: -196°C / -321°F (77K) up to +150°C / +302°F (423K), suitable for horizontal installation

Materials	DIN EN	ASME/ASTM
1 Outlet body	CC491K	B 62 UNS C83600
2 Inlet body	1.4301	A 276 Grade 304
4 Disc	1.4541	A 276 Grade 321
5 Guide plate	CW453K	B 103 UNS C52100
6 Stem	CW614N	B 283 UNS C38500
7 Spring	1.4571	A 313 Grade 316Ti
8 Bonnet	1.4301	A 276 Grade 304
9 Spring clamp	CW614N	B 283 UNS C38500
10 Thread ring	CW614N	B 283 UNS C38500
11 Cap	CW614N	B 283 UNS C38500
15 Braze fitting	1.4301	A 276 Grade 304
16 Union nut	CW614N	B 283 UNS C38500

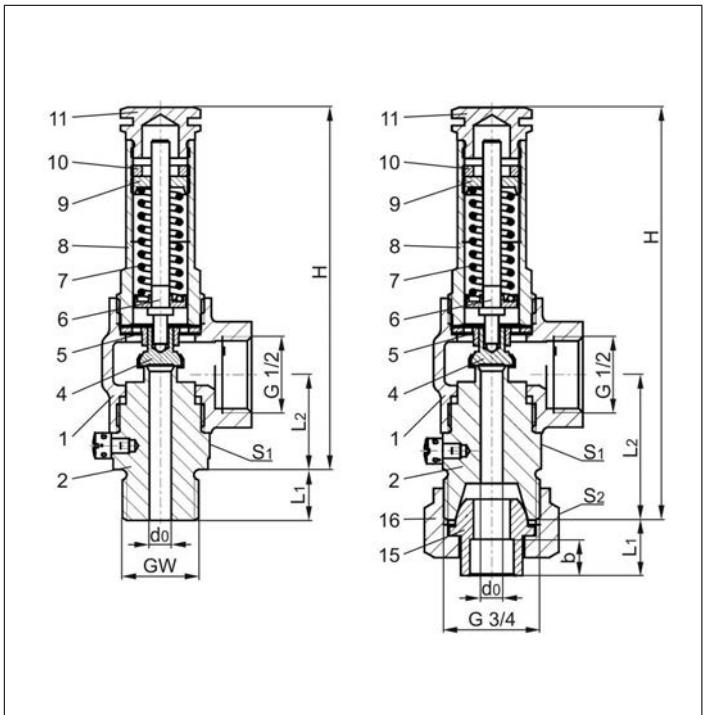

Essential: Valves are delivered at a set pressure, therefore when ordering please confirm set pressure, medium and temperature.

Standard marking acc. to Pressure Equipment Directive 97/23/EC (PED).



Type 06472	Technical data				
Nominal size	GW	1/4	3/8	1/2	3/4
Orifice	d ₀	6.0	6.0	6.0	6.0
Dimension code	.X.	0200	0300	0400	0600
Set pressure range	bar	0.5-6.0	0.5-6.0	0.5-6.0	0.5-6.0
Height	H	100	100	100	114
Length	L ₁	12	13	14	15.5
Length	L ₂	26	26	26	40
Socket depth	b	-	-	-	10
Wrench size across flats	S ₁	27	27	27	27
Wrench size across flats	S ₂	-	-	-	32
Weight	ca. kg	0.34	0.36	0.38	0.47
Coeff. of discharge from 3.0 bar	α _w	0.55	0.55	0.55	0.55

Dimensions in mm.

Safety Valves

Type 06472



Discharge capacities

Calculation of flow rate acc. to AD2000-Merkblatt A2 / DIN EN ISO 4126-1

Medium:

Air in m³/h at 0°C and 1013.25 mbar

The capacity indicated below is for a fully opened valve.

d₀ - orifice

A₀ - flow area

Set pressure in bar (g)	GW	1/4	3/8	1/2	3/4
	d ₀ (mm) A ₀ (mm ²) Medium	6.0 28.3	6.0 28.3	6.0 28.3	6.0 28.3
Air					
0.5		13	13	13	13
0.6		15	15	15	15
0.7		17	17	17	17
0.8		18	18	18	18
0.9		19	19	19	19
1.0		21	21	21	21
1.2		23	23	23	23
1.4		26	26	26	26
1.6		28	28	28	28
1.8		31	31	31	31
2.0		33	33	33	33
2.2		36	36	36	36
2.4		38	38	38	38
2.6		40	40	40	40
2.8		43	43	43	43
3.0		45	45	45	45
3.2		48	48	48	48
3.4		50	50	50	50
3.6		52	52	52	52
3.8		55	55	55	55
4.0		57	57	57	57
4.2		59	59	59	59
4.4		62	62	62	62
4.6		64	64	64	64
4.8		66	66	66	66
5.0		69	69	69	69
5.2		71	71	71	71
5.4		73	73	73	73
5.6		76	76	76	76
5.8		78	78	78	78
6.0		80	80	80	80

Safety Valves

Type 06477



Cryogenic Safety Valves, angle type, bronze, PN40, type tested TÜV-SV.836. S/G

Standard safety valve,
metal to metal seated, closed bonnet, with lifting device
Outlet: female thread G 1/2 acc. to ISO 228/1
"cleaned and degreased for oxygen service"

Part No. 06477.X.0000

Part No. 06477.0600.9000

Inlet: male thread type G (BSPP) acc. to ISO 228/1

Part No. 06477.X.5000

Inlet: male thread NPT acc. to ANSI B 1.20.1

Part No. 06477.0600.0000

Inlet: union type braze fitting for pipe outside diameter 12 mm

Available options - on request only:

- external parts nickel plated
- with installed elbow at the outlet



Applications:

Provided as safety device for protection against excessive pressure in stationary and moveable gas cylinders and pressure vessels. Approved for air gases, vapours and cryogenic liquefied gases incl. LNG.
Working temperature: -196°C / -321°F (77K) up to +150°C / +302°F (423K), suitable for horizontal installation

Materials	DIN EN	ASME/ASTM
1 Outlet body	CC491K	B 62 UNS C83600
2 Inlet body	1.4301	A 276 Grade 304
4 Disc	1.4541	A 276 Grade 321
5 Guide plate	CW453K	B 103 UNS C52100
6 Stem	CW614N	B 283 UNS C38500
7 Spring	1.4571	A 313 Grade 316Ti
8 Bonnet	1.4301	A 276 Grade 304
9 Spring clamp	CW614N	B 283 UNS C38500
10 Thread ring	CW614N	B 283 UNS C38500
11 Lifting cap	CW614N	B 283 UNS C38500
12 Lifting spring	1.4571	A 276 Grade 316Ti
13 Lifting stem	CW614N	B 283 UNS C38500
14 Lifting device	CW614N	B 283 UNS C38500
15 Braze fitting	1.4301	A 276 Grade 304
16 Union nut	CW614N	B 283 UNS C38500

Essential: Valves are delivered at a set pressure, therefore when ordering please confirm set pressure, medium and temperature.

Standard marking acc. to Pressure Equipment Directive 97/23/EC (PED).

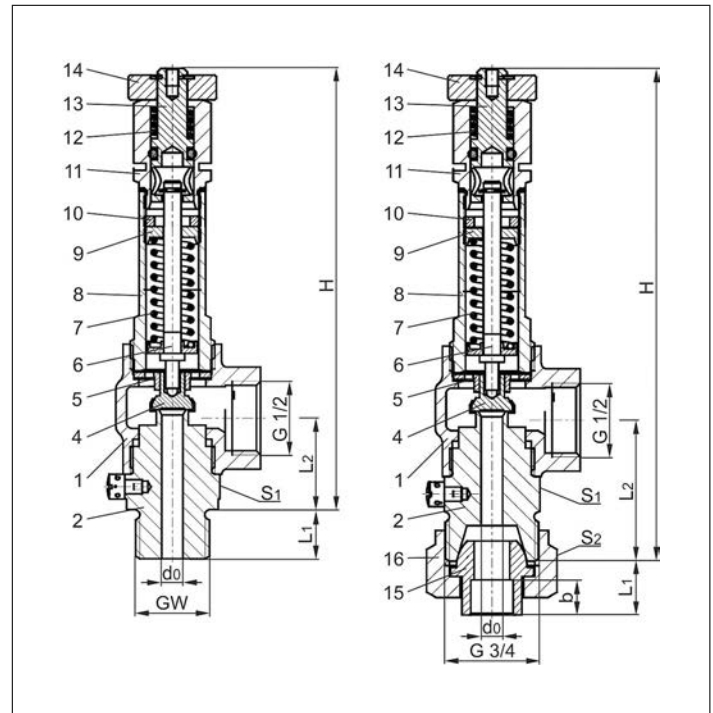

Type 06477	Technical data					
	Nominal size	GW	1/4	3/8	1/2	3/4
Orifice	d ₀	6.0	6.0	6.0	6.0	6.0
Dimension code	.X.	0200	0300	0400	0600	
Set pressure range	bar	0.5-6.0	0.5-6.0	0.5-6.0	0.5-6.0	
Height	H	126	126	126	140	
Length	L ₁	12	13	14	15.5	
Length	L ₂	26	26	26	40	
Socket depth	b	-	-	-	10	
Wrench size across flats	S ₁	27	27	27	27	
Wrench size across flats	S ₂	-	-	-	32	
Weight	ca. kg	0.40	0.42	0.44	0.48	
Coeff. of discharge from 3.0 bar	α _w	0.55	0.55	0.55	0.55	

Dimensions in mm.

Safety Valves

Type 06477



Discharge capacities

Calculation of flow rate acc. to AD2000-Merkblatt A2 / DIN EN ISO 4126-1

Medium:

Air in m³/h at 0°C and 1013.25 mbar

The capacity indicated below is for a fully opened valve.

d₀ - orifice

A₀ - flow area

Set pressure in bar (g)	GW	1/4	3/8	1/2	3/4
	d ₀ (mm) A ₀ (mm ²) Medium	6.0 28.3	6.0 28.3	6.0 28.3	6.0 28.3
Air					
0.5		14	14	14	14
0.6		15	15	15	15
0.7		17	17	17	17
0.8		19	19	19	19
0.9		20	20	20	20
1.0		21	21	21	21
1.2		23	23	23	23
1.4		26	26	26	26
1.6		29	29	29	29
1.8		31	31	31	31
2.0		33	33	33	33
2.2		36	36	36	36
2.4		38	38	38	38
2.6		40	40	40	40
2.8		43	43	43	43
3.0		46	46	46	46
3.2		48	48	48	48
3.4		50	50	50	50
3.6		53	53	53	53
3.8		55	55	55	55
4.0		57	57	57	57
4.2		60	60	60	60
4.4		62	62	62	62
4.6		64	64	64	64
4.8		67	67	67	67
5.0		69	69	69	69
5.2		71	71	71	71
5.4		74	74	74	74
5.6		76	76	76	76
5.8		78	78	78	78
6.0		81	81	81	81

Safety Valves

Type 06474



Cryogenic Safety Valves, angle type, bronze, PN63, type tested TÜV-SV.836. S/G

Standard safety valve,
with carbon filled PTFE valve seal, closed bonnet
Outlet: female thread G 1/2 acc. to ISO 228/1
"cleaned and degreased for oxygen service"

Part No. 06474.X.0000

Part No. 06474.0600.9000

Inlet: male thread type G (BSPP) acc. to ISO 228/1

Part No. 06474.X.5000

Inlet: male thread NPT acc. to ANSI B 1.20.1

Part No. 06474.0600.0000

Inlet: union type braze fitting for pipe outside diameter 12 mm

Available options - on request only:

- external parts nickel plated
- with installed elbow at the outlet



Applications:

Provided as safety device for protection against excessive pressure in stationary and moveable gas cylinders and pressure vessels. Approved for air gases, vapours and cryogenic liquefied gases incl. LNG.
Working temperature: -196°C / -321°F (77K) up to +150°C / +302°F (423K), suitable for horizontal installation

Materials	DIN EN	ASME/ASTM
1 Outlet body	CC491K	B 62 UNS C83600
2 Inlet body	1.4301	A 276 Grade 304
3 Valve seal	PTFE / Carbon filled (25%)	
4 Disc	CW452K	B 159 UNS C51900
5 Guide plate	CC493K	B 505 UNS C93200
6 Stem	CW614N	B 283 UNS C38500
7 Spring	1.4571	A 313 Grade 316Ti
8 Bonnet	1.4301	A 276 Grade 304
9 Spring clamp	CW614N	B 283 UNS C38500
10 Thread ring	CW614N	B 283 UNS C38500
11 Cap	CW614N	B 283 UNS C38500
15 Braze fitting	1.4301	A 276 Grade 304
16 Union nut	CW614N	B 283 UNS C38500

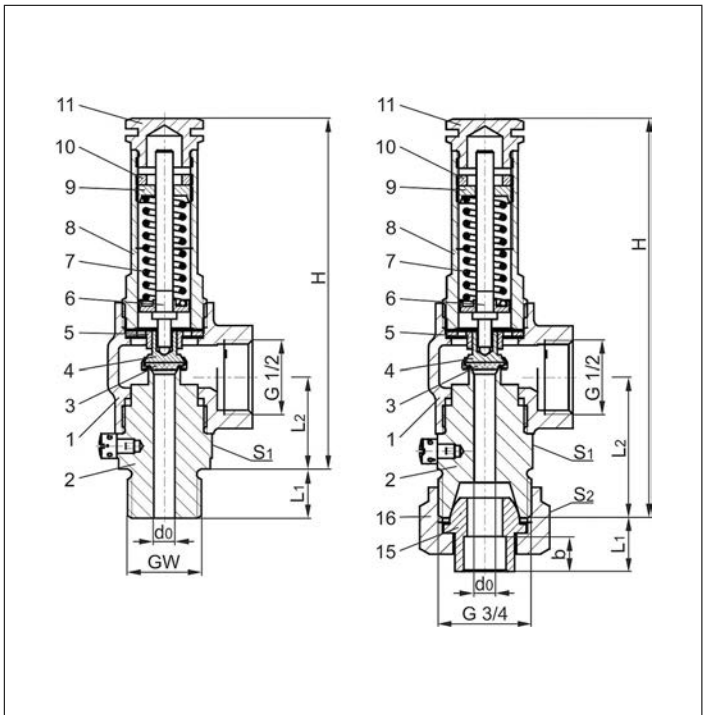

Essential: Valves are delivered at a set pressure, therefore when ordering please confirm set pressure, medium and temperature.

Standard marking acc. to Pressure Equipment Directive 97/23/EC (PED).



Type 06474	Technical data				
	GW	1/4	3/8	1/2	3/4
Nominal size	d ₀	6.0	6.0	6.0	6.0
Dimension code	.X.	0200	0300	0400	0600
Set pressure range	bar	4.5-45.0	4.5-45.0	4.5-45.0	4.5-45.0
Height	H	100	100	100	114
Length	L ₁	12	13	14	15.5
Length	L ₂	26	26	26	40
Socket depth	b	-	-	-	10
Wrench size across flats	S ₁	27	27	27	27
Wrench size across flats	S ₂	-	-	-	32
Weight	ca. kg	0.34	0.36	0.38	0.48
Coefficient of discharge	α _w	0.66	0.66	0.66	0.66

Dimensions in mm.

Safety Valves

Type 06474



Discharge capacities

Calculation of flow rate acc. to AD2000-Merkblatt A2 / DIN EN ISO 4126-1

Medium:

Air in m³/h at 0°C and 1013.25 mbar

The capacity indicated below is for a fully opened valve.

d₀ - orifice

A₀ - flow area

Set pressure in bar (g)	GW	1/4	3/8	1/2	3/4
	d ₀ (mm)	6.0	6.0	6.0	6.0
	A ₀ (mm ²)	28.3	28.3	28.3	28.3
	Medium	Air			
4.5		75	75	75	75
5.0		83	83	83	83
6.0		97	97	97	97
7.0		111	111	111	111
8.0		125	125	125	125
9.0		139	139	139	139
10.0		154	154	154	154
12.0		182	182	182	182
14.0		210	210	210	210
16.0		238	238	238	238
18.0		267	267	267	267
20.0		298	298	298	298
22.0		326	326	326	326
24.0		355	355	355	355
26.0		383	383	383	383
28.0		412	412	412	412
30.0		444	444	444	444
32.0		473	473	473	473
34.0		502	502	502	502
36.0		531	531	531	531
38.0		559	559	559	559
40.0		593	593	593	593
42.0		622	622	622	622
44.0		651	651	651	651
45.0		666	666	666	666

Safety Valves

Type 06478



Cryogenic Safety Valves, angle type, bronze, PN63, type tested TÜV-SV.836. S/G

Standard safety valve,
with carbon filled PTFE valve seal, closed bonnet, with lifting device

Outlet: female thread G 1/2 acc. to ISO 228/1

"cleaned and degreased for oxygen service"

Part No. 06478.X.0000

Part No. 06478.0600.9000

Inlet: male thread type G (BSPP) acc. to ISO 228/1

Part No. 06478.X.5000

Inlet: male thread NPT acc. to ANSI B 1.20.1

Part No. 06478.0600.0000

Inlet: union type braze fitting for pipe outside diameter 12 mm

Available options - on request only:

- external parts nickel plated
- with installed elbow at the outlet



Applications:

Provided as safety device for protection against excessive pressure in stationary and moveable gas cylinders and pressure vessels. Approved for air gases, vapours and cryogenic liquefied gases incl. LNG.

Working temperature: -196°C / -321°F (77K) up to +150°C / +302°F (423K), suitable for horizontal installation

Materials	DIN EN	ASME/ASTM
1 Outlet body	CC491K	B 62 UNS C83600
2 Inlet body	1.4301	A 276 Grade 304
3 Valve seal	PTFE / Carbon filled (25%)	
4 Disc	CW452K	B 159 UNS C51900
5 Guide plate	CC493K	B 505 UNS C93200
6 Stem	CW614N	B 283 UNS C38500
7 Spring	1.4571	A 313 Grade 316Ti
8 Bonnet	1.4301	A 276 Grade 304
9 Spring clamp	CW614N	B 283 UNS C38500
10 Thread ring	CW614N	B 283 UNS C38500
11 Lifting cap	CW614N	B 283 UNS C38500
12 Lifting spring	1.4571	A 276 Grade 316Ti
13 Lifting stem	CW614N	B 283 UNS C38500
14 Lifting device	CW614N	B 283 UNS C38500
15 Braze fitting	1.4301	A 276 Grade 304
16 Union nut	CW614N	B 283 UNS C38500

Essential: Valves are delivered at a set pressure, therefore when ordering please confirm set pressure, medium and temperature.

Standard marking acc. to Pressure Equipment Directive 97/23/EC (PED).

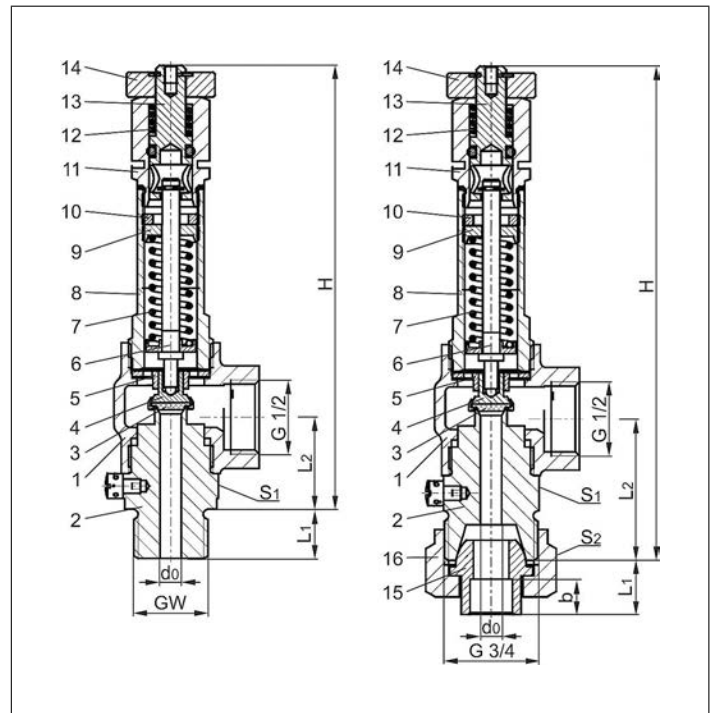

Type 06478	Technical data				
Nominal size	GW	1/4	3/8	1/2	3/4
Orifice	d ₀	6.0	6.0	6.0	6.0
Dimension code	.X.	0200	0300	0400	0600
Set pressure range	bar	4.5-45.0	4.5-45.0	4.5-45.0	4.5-45.0
Height	H	126	126	126	140
Length	L ₁	12	13	14	15.5
Length	L ₂	26	26	26	40
Socket depth	b	-	-	-	10
Wrench size across flats	S ₁	27	27	27	27
Wrench size across flats	S ₂	-	-	-	32
Weight	ca. kg	0.40	0.42	0.44	0.47
Coefficient of discharge	α _w	0.66	0.66	0.66	0.66

Dimensions in mm.

Safety Valves

Type 06478



Discharge capacities

Calculation of flow rate acc. to AD2000-Merkblatt A2 / DIN EN ISO 4126-1

Medium:

Air in m³/h at 0°C and 1013.25 mbar

The capacity indicated below is for a fully opened valve.

d_0 - orifice

A_0 - flow area

Set pressure in bar (g)	GW	1/4	3/8	1/2	3/4
	d_0 (mm)	6.0	6.0	6.0	6.0
	A_0 (mm ²)	28.3	28.3	28.3	28.3
	Medium	Air			
4.5		76	76	76	76
5.0		83	83	83	83
6.0		97	97	97	97
7.0		111	111	111	111
8.0		125	125	125	125
9.0		139	139	139	139
10.0		153	153	153	153
12.0		181	181	181	181
14.0		209	209	209	209
16.0		237	237	237	237
18.0		265	265	265	265
20.0		293	293	293	293
22.0		321	321	321	321
24.0		349	349	349	349
26.0		377	377	377	377
28.0		404	404	404	404
30.0		432	432	432	432
32.0		460	460	460	460
34.0		488	488	488	488
36.0		516	516	516	516
38.0		544	544	544	544
40.0		572	572	572	572
42.0		600	600	600	600
44.0		628	628	628	628
45.0		642	642	642	642

Safety Valves

Type 06386



Cryogenic Safety Valves, angle type, bronze, PN40, type tested TÜV-SV.780. S/G

Standard safety valve (0.2 - 25.0/40.0 bar)

Metal to metal seated, closed bonnet

"cleaned and degreased for oxygen service"

Part No. 06386.X.0000

Inlet: male thread type G (BSPP) acc. to ISO 228/1, Outlet: female thread type G (BSPP) acc. to ISO 228/1

Part No. 06386.X.2000

Inlet: male thread type R (BSPT) acc. to ISO 7/1, Outlet: female thread type G (BSPP) acc. to ISO 228/1

Part No. 06386.X.5000

Inlet: male thread NPT acc. to ANSI B 1.20.1, Outlet: female thread type G (BSPP) acc. to ISO 228/1

Part No. 06386.X.6000

Inlet: male thread NPT acc. to ANSI B 1.20.1, Outlet: female thread NPT acc. to ANSI B 1.20.1

Available options - on request only:

- external parts nickel plated
- with installed elbow at the outlet



Applications:

Provided as safety device for protection against excessive pressure in stationary and moveable gas cylinders and pressure vessels. Approved for air gases, vapours and cryogenic liquefied gases incl. LNG.

Working temperature: -196°C / -321°F (77K) up to +185°C / +365°F (458K)

Materials	DIN EN	ASME/ASTM
1 Outlet body	CC491K	B 62 UNS C83600
2 Inlet body	1.4301	A 276 Grade 304
4 Disc	1.4541	A 276 Grade 321
5 Guide plate	CW453K	B 103 UNS C52100
6 Stem	CW453K	B 103 UNS C52100
7 Spring	1.4571	A 313 Grade 316Ti
8 Bonnet	1.4308	A 351 CF 8
9 Spring clamp	CW614N	B 283 UNS C38500
10 Thread ring	CW614N	B 283 UNS C38500
11 Cap	CW614N	B 283 UNS C38500

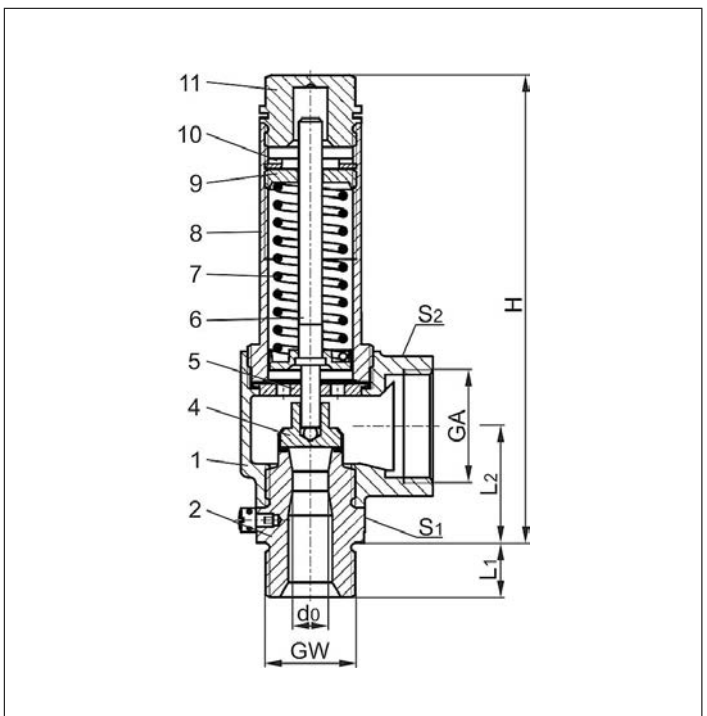

Essential: Valves are delivered at a set pressure, therefore when ordering please confirm set pressure, medium and temperature.

Standard marking acc. to Pressure Equipment Directive 97/23/EC (PED).



Type 06386	Technical data				
	Nominal size	GW	1/2	3/4	1
Orifice	d ₀	10.5	10.5	14.0	
Dimension code	.X.	1004	1006	1410	
Set pressure range	bar	0.2-25.0	0.2-25.0	0.2-40.0	
Outlet	GA	1	1	1-1/4	
Height	H	140	140	157	
Length	L ₁	14	16	18	
Length	L ₂	36	36	42	
Wrench size across flats	S ₁	30	30	41	
Wrench size across flats	S ₂	41	41	50	
Weight	ca. kg	0.75	0.78	1.24	
Coeff. of discharge from 3.0 bar	α _w	0.67	0.67	0.67	

Dimensions in mm.

Safety Valves

Type 06386



Discharge capacities

Calculation of flow rate acc. to AD2000-Merkblatt A2 / DIN EN ISO 4126-1

Medium:

Air in m³/h at 0°C and 1013.25 mbar

The capacity indicated below is for a fully opened valve.

d_0 - orifice

A_0 - flow area

Set pressure in bar (g)	GW	1/2 & 3/4	1
	d_0 (mm)	10.5	14.0
	A_0 (mm ²)	86.6	153.9
	Medium	Air	
0.2		25	49
0.5		48	87
1.0		74	135
1.5		99	175
2.0		123	217
3.0		170	303
4.0		214	381
5.0		258	459
6.0		302	537
7.0		345	614
8.0		390	694
9.0		434	772
10.0		479	851
12.0		566	1007
14.0		654	1163
16.0		742	1319
18.0		830	1475
20.0		926	1647
22.0		1015	1805
24.0		1103	1962
25.0		1148	2041
26.0		-	2120
28.0		-	2277
30.0		-	2458
32.0		-	2617
34.0		-	2776
36.0		-	2934
38.0		-	3093
40.0		-	3280

Safety Valves

Type 06416



Cryogenic Safety Valves, angle type, bronze, PN40, type tested TÜV-SV.780. S/G

Standard safety valve (0.2 - 25.0/40.0 bar)

Metal to metal seated, closed bonnet, with lifting device

"cleaned and degreased for oxygen service"

Part No. 06416.X.0000

Inlet: male thread type G (BSPP) acc. to ISO 228/1, Outlet: female thread type G (BSPP) acc. to ISO 228/1

Part No. 06416.X.2000

Inlet: male thread type R (BSPT) acc. to ISO 7/1, Outlet: female thread type G (BSPP) acc. to ISO 228/1

Part No. 06416.X.5000

Inlet: male thread NPT acc. to ANSI B 1.20.1, Outlet: female thread type G (BSPP) acc. to ISO 228/1

Part No. 06416.X.6000

Inlet: male thread NPT acc. to ANSI B 1.20.1, Outlet: female thread NPT acc. to ANSI B 1.20.1

Available options - on request only:

- external parts nickel plated
- with installed elbow at the outlet



Applications:

Provided as safety device for protection against excessive pressure in stationary and moveable gas cylinders and pressure vessels. Approved for air gases, vapours and cryogenic liquefied gases incl. LNG.

Working temperature: -196°C / -321°F (77K) up to +185°C / +365°F (458K)

Materials	DIN EN	ASME/ASTM
1 Outlet body	CC491K	B 62 UNS C83600
2 Inlet body	1.4301	A 276 Grade 304
4 Disc	1.4541	A 276 Grade 321
5 Guide plate	CW453K	B 103 UNS C52100
6 Stem	CW453K	B 103 UNS C52100
7 Spring	1.4571	A 313 Grade 316Ti
8 Bonnet	1.4308	A 351 CF 8
9 Spring clamp	CW614N	B 283 UNS C38500
10 Thread ring	CW614N	B 283 UNS C38500
11 Lifting cap	CW614N	B 283 UNS C38500
12 Lifting spring	1.4571	A 276 Grade 316Ti
13 Lifting stem	CW614N	B 283 UNS C38500
14 Lever	1.4408	A 351 CF8M

Essential: Valves are delivered at a set pressure, therefore when ordering please confirm set pressure, medium and temperature.

Standard marking acc. to Pressure Equipment Directive 97/23/EC (PED).

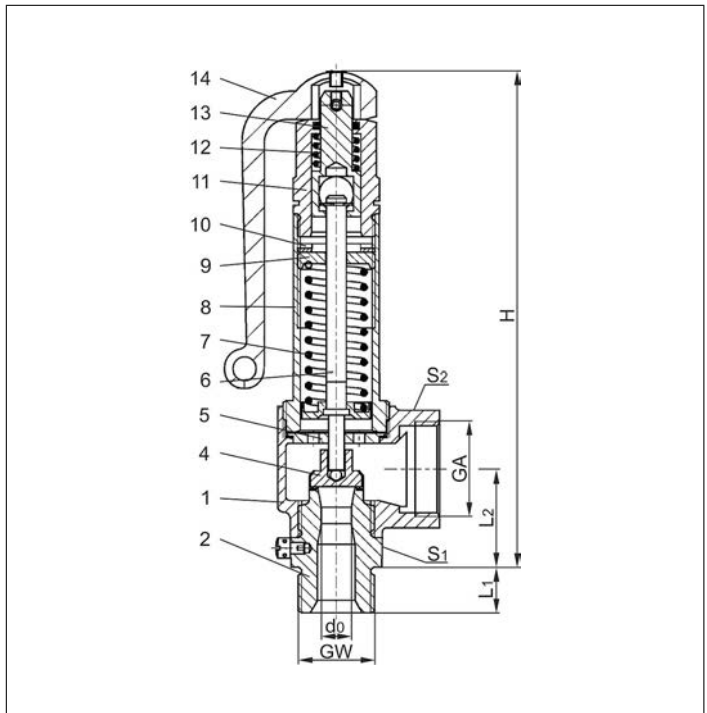

Type 06416	Technical data				
	Nominal size	GW	1/2	3/4	1
Orifice	d ₀	10.5	10.5	14.0	
Dimension code	.X.	1004	1006	1410	
Set pressure range	bar	0.2-25.0	0.2-25.0	0.2-40.0	
Outlet	GA	1	1	1-1/4	
Height	H	175	175	194	
Length	L ₁	14	16	18	
Length	L ₂	36	36	42	
Wrench size across flats	S ₁	30	30	41	
Wrench size across flats	S ₂	41	41	50	
Weight	ca. kg	0.96	1.00	1.50	
Coeff. of discharge from 3.0 bar	α _w	0.67	0.67	0.67	

Dimensions in mm.

Safety Valves

Type 06416



Discharge capacities

Calculation of flow rate acc. to AD2000-Merkblatt A2 / DIN EN ISO 4126-1

Medium:

Air in m³/h at 0°C and 1013.25 mbar

The capacity indicated below is for a fully opened valve.

d_0 - orifice

A_0 - flow area

Set pressure in bar (g)	GW	1/2 & 3/4	1
	d_0 (mm)	10.5	14.0
	A_0 (mm ²)	86.6	153.9
	Medium	Air	
0.2		25	49
0.5		48	87
1.0		74	135
1.5		99	175
2.0		123	217
3.0		170	303
4.0		214	381
5.0		258	459
6.0		302	537
7.0		345	614
8.0		390	694
9.0		434	772
10.0		479	851
12.0		566	1007
14.0		654	1163
16.0		742	1319
18.0		830	1475
20.0		926	1647
22.0		1015	1805
24.0		1103	1962
25.0		1148	2041
26.0		-	2120
28.0		-	2277
30.0		-	2458
32.0		-	2617
34.0		-	2776
36.0		-	2934
38.0		-	3093
40.0		-	3280

Safety Valves

Type 06387



Cryogenic Safety Valves, angle type, bronze, PN40, type tested TÜV-SV.780. S/G

Standard safety valve (0.2 - 25.0 bar)

Metal to metal seated, closed bonnet

"cleaned and degreased for oxygen service"

Part No. 06387.X.0000

Inlet: female thread type G (BSPP) acc. to ISO 228/1

Outlet: female thread type G (BSPP) acc. to ISO 228/1

Available options - on request only:

- external parts nickel plated · with installed elbow at the outlet



Applications:

Provided as safety device for protection against excessive pressure in stationary and moveable gas cylinders and pressure vessels. Approved for air gases, vapours and cryogenic liquefied gases incl. LNG.

Working temperature: -196°C / -321°F (77K) up to +185°C / +365°F (458K)

Materials	DIN EN	ASME/ASTM
1 Outlet body	CC491K	B 62 UNS C83600
2 Inlet body	1.4301	A 276 Grade 304
4 Disc	1.4541	A 276 Grade 321
5 Guide plate	CW453K	B 103 UNS C52100
6 Stem	CW453K	B 103 UNS C52100
7 Spring	1.4571	A 313 Grade 316Ti
8 Bonnet	1.4308	A 351 CF 8
9 Spring clamp	CW614N	B 283 UNS C38500
10 Thread ring	CW614N	B 283 UNS C38500
11 Cap	CW614N	B 283 UNS C38500

Essential: Valves are delivered at a set pressure, therefore when ordering please confirm set pressure, medium and temperature.

Standard marking acc. to Pressure Equipment Directive 97/23/EC (PED).

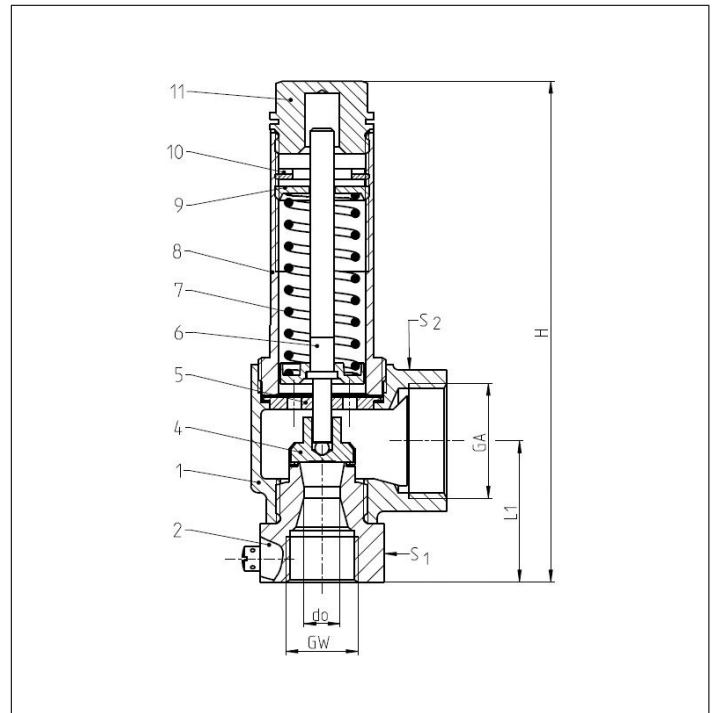

Type 06387	Technical data	
Nominal size	GW	1/2
Orifice	d ₀	10.5
Dimension code	.X.	1004
Set pressure range	bar	0.2-25.0
Outlet	GA	1
Height	H	144
Length	L ₁	41
Wrench size across flats	S ₁	36
Wrench size across flats	S ₂	41
Weight	ca. kg	0.78
Coeff. of discharge from 3.0 bar	α _w	0.67

Dimensions in mm.

Safety Valves

Type 06387



Discharge capacities

Calculation of flow rate acc. to AD2000-Merkblatt A2 / DIN EN ISO 4126-1

Medium:

Air in m³/h at 0°C and 1013.25 mbar

The capacity indicated below is for a fully opened valve.

d₀ - orifice

A₀ - flow area

Set pressure in bar (g)	GW	1/2
	d ₀ (mm)	10.5
	A ₀ (mm ²)	86.6
	Medium	Air
0.2		25
0.5		48
1.0		74
1.5		99
2.0		124
3.0		170
4.0		214
5.0		258
6.0		302
7.0		345
8.0		390
9.0		434
10.0		479
12.0		566
14.0		654
16.0		742
18.0		830
20.0		926
22.0		1015
24.0		1103
25.0		1148
26.0		-
28.0		-
30.0		-
32.0		-
34.0		-
36.0		-
38.0		-
40.0		-

Safety Valves

Type 06417



Cryogenic Safety Valves, angle type, bronze, PN40, type tested TÜV-SV.780. S/G

Standard safety valve (0.2 - 25.0 bar)

Metal to metal seated, closed bonnet, with lifting device

"cleaned and degreased for oxygen service"

Part No. 06417.X.0000

Inlet: female thread type G (BSPP) acc. to ISO 228/1

Outlet: female thread type G (BSPP) acc. to ISO 228/1

Available options - on request only:

- external parts nickel plated · with installed elbow at the outlet

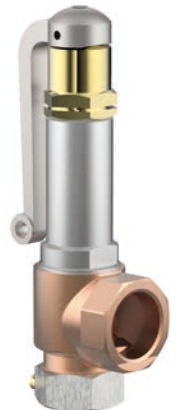

Applications:

Provided as safety device for protection against excessive pressure in stationary and moveable gas cylinders and pressure vessels. Approved for air gases, vapours and cryogenic liquefied gases incl. LNG.

Working temperature: -196°C / -321°F (77K) up to +185°C / +365°F (458K)

Materials	DIN EN	ASME/ASTM
1 Outlet body	CC491K	B 62 UNS C83600
2 Inlet body	1.4301	A 276 Grade 304
4 Disc	1.4541	A 276 Grade 321
5 Guide plate	CW453K	B 103 UNS C52100
6 Stem	CW453K	B 103 UNS C52100
7 Spring	1.4571	A 313 Grade 316Ti
8 Bonnet	1.4308	A 351 CF 8
9 Spring clamp	CW614N	B 283 UNS C38500
10 Thread ring	CW614N	B 283 UNS C38500
11 Lifting cap	CW614N	B 283 UNS C38500
12 Lifting spring	1.4571	A 276 Grade 316Ti
13 Lifting stem	CW614N	B 283 UNS C38500
14 Lever	1.4408	A 351 CF8M

Essential: Valves are delivered at a set pressure, therefore when ordering please confirm set pressure, medium and temperature.

Standard marking acc. to Pressure Equipment Directive 97/23/EC (PED).

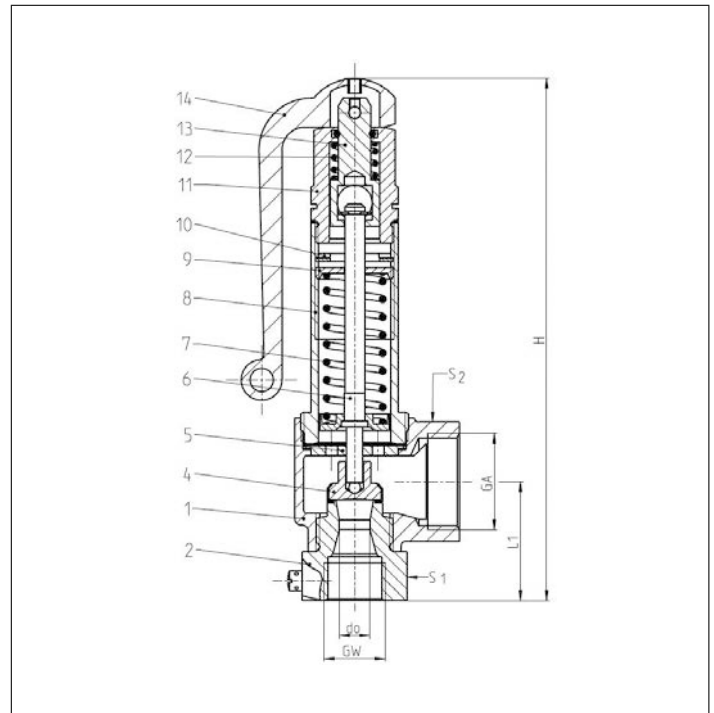

Type 06417	Technical data	
Nominal size	GW	1/2
Orifice	d ₀	10.5
Dimension code	.X.	1004
Set pressure range	bar	0.2-25.0
Outlet	GA	1
Height	H	180
Length	L ₁	41
Wrench size across flats	S ₁	30
Wrench size across flats	S ₂	41
Weight	ca. kg	0.99
Coeff. of discharge from 3.0 bar	α _w	0.67

Dimensions in mm.

Safety Valves

Type 06417



Discharge capacities

Calculation of flow rate acc. to AD2000-Merkblatt A2 / DIN EN ISO 4126-1

Medium:

Air in m³/h at 0°C and 1013.25 mbar

The capacity indicated below is for a fully opened valve.

d_0 - orifice

A_0 - flow area

Set pressure in bar (g)	GW	1/2
	d_0 (mm)	10.5
	A_0 (mm ²)	86.6
	Medium	Air
0.2		25
0.5		48
1.0		74
1.5		99
2.0		124
3.0		170
4.0		214
5.0		258
6.0		302
7.0		345
8.0		390
9.0		434
10.0		479
12.0		566
14.0		654
16.0		742
18.0		830
20.0		926
22.0		1015
24.0		1103
25.0		1148
26.0		-
28.0		-
30.0		-
32.0		-
34.0		-
36.0		-
38.0		-
40.0		-

Safety Valves

Type 06388



Cryogenic Safety Valve, angle type, bronze, PN50, type tested TÜV-SV.780. S/G

Full lift safety valve, orifice $d_0=23\text{mm}$ standard safety valve,
with carbon filled PTFE valve seal, closed bonnet
"cleaned and degreased for oxygen service"

Part No. 06388.X.0000

Inlet: male thread type G (BSPP) acc. to ISO 228/1, Outlet: female thread type G (BSPP) acc. to ISO 228/1

Part No. 06388.X.2000

Inlet: male thread type R (BSPT) acc. to ISO 7/1, Outlet: female thread type G (BSPP) acc. to ISO 228/1

Part No. 06388.X.5000

Inlet: male thread NPT acc. to ANSI B 1.20.1, Outlet: female thread type G (BSPP) acc. to ISO 228/1

Part No. 06388.X.6000

Inlet: male thread NPT acc. to ANSI B 1.20.1, Outlet: female thread NPT acc. to ANSI B 1.20.1

Available options - on request only:

- external parts nickel plated · with installed elbow at the outlet
- with additional drain hole at the outlet (1)



Applications:

Provided as safety device for protection against excessive pressure in stationary and moveable gas cylinders and pressure vessels. Approved for air gases, vapours and cryogenic liquefied gases incl. LNG.
Working temperature: $-196^\circ\text{C} / -321^\circ\text{F} (77\text{K})$ up to $+185^\circ\text{C} / +365^\circ\text{F} (458\text{K})$, suitable for horizontal installation

Materials	DIN EN	ASME/ASTM
1 Outlet body	CC491K	B 62 UNS C83600
2 Inlet body	1.4301	SA 479 Grade 304
3 Valve seal	PTFE / Carbon filled (25%)	
4 Disc	CC493K	SB 505 UNS C93200
5 Guide plate	CC493K	SB 505 UNS C93200
5a Guide plate from GW 1	CC453K	SB 103 UNS C52100
6 Stem	CW453K	SB 103 UNS C52100
7 Spring	1.4571	A 313 Grade 316Ti
8 Bonnet	1.4308	A 351 CF 8
9 Spring clamp	CW614N	B 455 UNS C38500
10 Thread ring	CW614N	B 455 UNS C38500
11 Cap	CW614N	B 455 UNS C38500

Essential: Valves are delivered at a set pressure, therefore when ordering please confirm set pressure, medium and temperature.

Standard marking acc. to Pressure Equipment Directive 97/23/EC (PED) and ASME Code Section VIII.

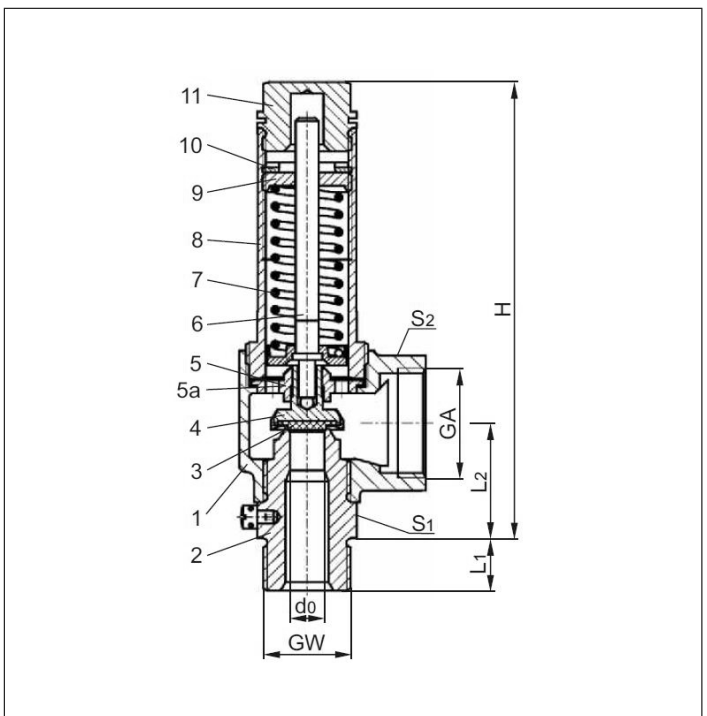

Type 06388	Technical data									
	Nominal size	GW	1/2	3/4	1	1-1/4	1-1/2	2		
Orifice	d_0	7.0	7.0	10.5	10.5	15.0	23.0	23.0	23.0	
Dimension code	.X.	0704	0706	1004	1006	1510	2312	2314	2320	
Set pressure range	bar	3.3-50.0	3.3-50.0	2.9-50.0	2.9-50.0	2.9-50.0	2.0-50.0	2.0-50.0	2.0-50.0	
Outlet	GA	1	1	1	1	1-1/4	2	2	2	
Height	H	140	140	140	140	157	218	218	216	
Length	L_1	14	16	14	16	18	20	20	25	
Length	L_2	36	36	36	36	42	56	56	54	
Wrench size across flats	S_1	30	30	30	30	41	55	55	65	
Wrench size across flats	S_2	41	41	41	41	50	70	70	70	
Weight	ca. kg	0.78	0.80	0.76	0.79	1.27	3.05	3.10	3.30	
Coefficient of discharge	α_w	0.82	0.82	0.58	0.58	0.5	0.62	0.62	0.62	
Coefficient of discharge	rated slope	0.862	0.862	1.517	1.517	2.769	7.55	7.55	7.55	

Dimensions in mm.

Safety Valves

Type 06388



Discharge capacities

Medium:

Air in m³/h at 0°C and 1013.25 mbar

Air in SCFM at 60°F (15.6°C) and 14.7 psia (1013.25 mbar)

The capacity indicated below is for a fully opened valve.

d₀ - orifice

A₀ - flow area

Calculation of discharge capacity acc. to AD2000-Merkblatt A2 / DIN EN ISO 4126-1 resp. ASME Code Sec. VIII.
The safety valve is marked with the lower capacity of both calculations.

Set pressure in bar (g)	GW	1/2 & 3/4	1/2 & 3/4	1	1-1/4, 1-1/2 & 2	Set pressure in psig	GW	1/2 & 3/4	1/2 & 3/4	1	1-1/4, 1-1/2 & 2
	d ₀ (mm)	7.0	10.5	15.0	23.0		d ₀ (inch)	0.276	0.414	0.591	0.907
	A ₀ (mm ²)	38.48	86.6	176.63	415.27		A ₀ (in ²)	0.060	0.134	0.274	0.644
	Medium	Air in m ³ /h					Medium	Air in SCFM			
2.0	-	-	-	-	563	50	60	102	180	524	
2.9	-	143	252	737	60	60	70	118	208	607	
3.0	-	147	259	756	70	70	79	134	236	690	
3.3	93	158	279	814	80	80	89	150	265	772	
4.0	108	185	325	949	90	90	98	167	294	855	
5.0	130	222	391	1142	100	100	107	183	322	938	
6.0	153	260	458	1335	110	110	117	199	350	1021	
7.0	174	298	524	1528	120	120	126	215	379	1103	
8.0	196	335	590	1721	130	130	136	231	407	1186	
9.0	219	373	656	1914	140	140	145	248	435	1269	
10.0	241	410	722	2107	150	150	155	264	464	1352	
12.0	285	486	855	2493	175	175	179	304	535	1558	
14.0	330	561	987	2879	200	200	202	344	606	1766	
16.0	373	636	1119	3265	225	225	226	384	677	1972	
18.0	418	711	1252	3651	250	250	250	425	748	2179	
20.0	461	787	1384	4037	275	275	273	465	818	2386	
22.0	507	862	1517	4422	300	300	297	506	889	2593	
24.0	550	937	1649	4808	325	325	321	546	960	2800	
26.0	595	1012	1781	5194	350	350	345	586	1031	3007	
28.0	638	1088	1914	5580	375	375	368	626	1102	3213	
30.0	683	1163	2046	5966	400	400	392	667	1173	3420	
32.0	727	1238	2178	6352	425	425	416	707	1244	3627	
34.0	772	1313	2311	6738	450	450	439	748	1315	3834	
36.0	815	1389	2443	7124	475	475	463	788	1386	4041	
38.0	860	1464	2576	7510	500	500	487	828	1457	4248	
40.0	904	1539	2708	7896	525	525	510	869	1528	4455	
42.0	949	1614	2840	8282	550	550	534	909	1599	4662	
44.0	992	1690	2973	8668	575	575	558	949	1670	4868	
46.0	1037	1765	3105	9054	625	625	605	1030	1812	5282	
48.0	1081	1840	3238	9440	675	675	653	1111	1954	5696	
50.0	1126	1915	3370	9825	725	725	700	1191	2096	6109	

Safety Valves

Type 06388



Cryogenic Safety Valve, angle type, bronze, PN50, type tested TÜV-SV.780. S/G

Full lift safety valve, orifice $d_0=23\text{mm}$ standard safety valve,
with carbon filled PTFE valve seal, closed bonnet
"cleaned and degreased for oxygen service"

Part No. 06388.X.0040

Inlet: male thread type G (BSPP) acc. to ISO 228/1, Outlet: female thread type G (BSPP) acc. to ISO 228/1

Part No. 06388.X.2040

Inlet: male thread type R (BSPT) acc. to ISO 7/1, Outlet: female thread type G (BSPP) acc. to ISO 228/1

Part No. 06388.X.5040

Inlet: male thread NPT acc. to ANSI B 1.20.1, Outlet: female thread type G (BSPP) acc. to ISO 228/1

Part No. 06388.X.6040

Inlet: male thread NPT acc. to ANSI B 1.20.1, Outlet: female thread NPT acc. to ANSI B 1.20.1

Available options - on request only:

- external parts nickel plated · with installed elbow at the outlet
- with additional drain hole at the outlet (1)



Applications:

Provided as safety device for protection against excessive pressure in stationary and moveable gas cylinders and pressure vessels. Approved for air gases, vapours and cryogenic liquefied gases incl. LNG.
Working temperature: $-196^\circ\text{C} / -321^\circ\text{F} (77\text{K})$ up to $+185^\circ\text{C} / +365^\circ\text{F} (458\text{K})$, suitable for horizontal installation

Materials	DIN EN	ASME/ASTM
1 Outlet body	CC491K	B 62 UNS C83600
2 Inlet body	CW614N	B 455 UNS C38500
3 Valve seal	PTFE / Carbon filled (25%)	
4 Disc	CC493K	SB 505 UNS C93200
5 Guide plate	CC493K	SB 505 UNS C93200
5a Guide plate from GW 1	CC453K	SB 103 UNS C52100
6 Stem	CW453K	SB 103 UNS C52100
7 Spring	1.4571	A 313 Grade 316Ti
8 Bonnet	1.4308	A 351 CF 8
9 Spring clamp	CW614N	B 455 UNS C38500
10 Thread ring	CW614N	B 455 UNS C38500
11 Cap	CW614N	B 455 UNS C38500

Essential: Valves are delivered at a set pressure, therefore when ordering please confirm set pressure, medium and temperature.

Standard marking acc. to Pressure Equipment Directive 97/23/EC (PED) and ASME Code Section VIII.

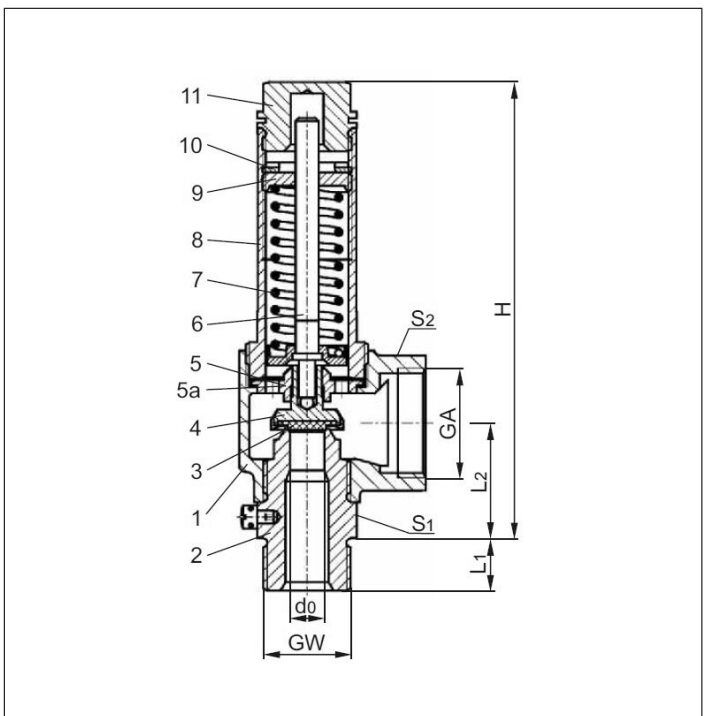

Type 06388	Technical data									
	Nominal size	GW	1/2	3/4	1	1-1/4	1-1/2	2		
Orifice	d_0	7.0	7.0	10.5	10.5	15.0	23.0	23.0	23.0	
Dimension code	.X.	0704	0706	1004	1006	1510	2312	2314	2320	
Set pressure range	bar	3.3-50.0	3.3-50.0	2.9-50.0	2.9-50.0	2.9-50.0	2.0-50.0	2.0-50.0	2.0-50.0	
Outlet	GA	1	1	1	1	1-1/4	2	2	2	
Height	H	140	140	140	140	157	218	218	216	
Length	L_1	14	16	14	16	18	20	20	25	
Length	L_2	36	36	36	36	42	56	56	54	
Wrench size across flats	S_1	30	30	30	30	41	55	55	65	
Wrench size across flats	S_2	41	41	41	41	50	70	70	70	
Weight	ca. kg	0.78	0.80	0.76	0.79	1.27	3.05	3.10	3.30	
Coefficient of discharge	α_w	0.82	0.82	0.58	0.58	0.5	0.62	0.62	0.62	
Coefficient of discharge	rated slope	0.862	0.862	1.517	1.517	2.769	7.55	7.55	7.55	

Dimensions in mm.

Safety Valves

Type 06388



Discharge capacities

Medium:

Air in m³/h at 0°C and 1013.25 mbar

Air in SCFM at 60°F (15.6°C) and 14.7 psia (1013.25 mbar)

The capacity indicated below is for a fully opened valve.

d₀ - orifice

A₀ - flow area

Calculation of discharge capacity acc. to AD2000-Merkblatt A2 / DIN EN ISO 4126-1 resp. ASME Code Sec. VIII.
The safety valve is marked with the lower capacity of both calculations.

Set pressure in bar (g)	GW	1/2 & 3/4	1/2 & 3/4	1	1-1/4, 1-1/2 & 2	Set pressure in psig	GW	1/2 & 3/4	1/2 & 3/4	1	1-1/4, 1-1/2 & 2
	d ₀ (mm)	7.0	10.5	15.0	23.0		d ₀ (inch)	0.276	0.414	0.591	0.907
	A ₀ (mm ²)	38.48	86.6	176.63	415.27		A ₀ (in ²)	0.060	0.134	0.274	0.644
	Medium	Air in m ³ /h					Medium	Air in SCFM			
2.0	-	-	-	-	563	50	60	102	180	524	
2.9	-	143	252	737	60	70	118	208	607		
3.0	-	147	259	756	70	79	134	236	690		
3.3	93	158	279	814	80	89	150	265	772		
4.0	108	185	325	949	90	98	167	294	855		
5.0	130	222	391	1142	100	107	183	322	938		
6.0	153	260	458	1335	110	117	199	350	1021		
7.0	174	298	524	1528	120	126	215	379	1103		
8.0	196	335	590	1721	130	136	231	407	1186		
9.0	219	373	656	1914	140	145	248	435	1269		
10.0	241	410	722	2107	150	155	264	464	1352		
12.0	285	486	855	2493	175	179	304	535	1558		
14.0	330	561	987	2879	200	202	344	606	1766		
16.0	373	636	1119	3265	225	226	384	677	1972		
18.0	418	711	1252	3651	250	250	425	748	2179		
20.0	461	787	1384	4037	275	273	465	818	2386		
22.0	507	862	1517	4422	300	297	506	889	2593		
24.0	550	937	1649	4808	325	321	546	960	2800		
26.0	595	1012	1781	5194	350	345	586	1031	3007		
28.0	638	1088	1914	5580	375	368	626	1102	3213		
30.0	683	1163	2046	5966	400	392	667	1173	3420		
32.0	727	1238	2178	6352	425	416	707	1244	3627		
34.0	772	1313	2311	6738	450	439	748	1315	3834		
36.0	815	1389	2443	7124	475	463	788	1386	4041		
38.0	860	1464	2576	7510	500	487	828	1457	4248		
40.0	904	1539	2708	7896	525	510	869	1528	4455		
42.0	949	1614	2840	8282	550	534	909	1599	4662		
44.0	992	1690	2973	8668	575	558	949	1670	4868		
46.0	1037	1765	3105	9054	625	605	1030	1812	5282		
48.0	1081	1840	3238	9440	675	653	1111	1954	5696		
50.0	1126	1915	3370	9825	725	700	1191	2096	6109		

Safety Valves

Type 06418



Cryogenic Safety Valve, angle type, bronze, PN50, type tested TÜV-SV.780. S/G

Full lift safety valve, orifice $d_0=23\text{mm}$ standard safety valve,
with carbon filled PTFE valve seal, closed bonnet, with lifting device
"cleaned and degreased for oxygen service"

Part No. 06418.X.0000

Inlet: male thread type G (BSPP) acc. to ISO 228/1, Outlet: female thread type G (BSPP) acc. to ISO 228/1

Part No. 06418.X.2000

Inlet: male thread type R (BSPT) acc. to ISO 7/1, Outlet: female thread type G (BSPP) acc. to ISO 228/1

Part No. 06418.X.5000

Inlet: male thread NPT acc. to ANSI B 1.20.1, Outlet: female thread type G (BSPP) acc. to ISO 228/1

Part No. 06418.X.6000

Inlet: male thread NPT acc. to ANSI B 1.20.1, Outlet: female thread NPT acc. to ANSI B 1.20.1

Available options - on request only:

- external parts nickel plated · with installed elbow at the outlet



Applications:

Provided as safety device for protection against excessive pressure in stationary and moveable gas cylinders and pressure vessels. Approved for air gases, vapours and cryogenic liquefied gases incl. LNG.
Working temperature: $-196^\circ\text{C} / -321^\circ\text{F}$ (77K) up to $+185^\circ\text{C} / +365^\circ\text{F}$ (458K), suitable for horizontal installation

Materials	DIN EN	ASME/ASTM
1 Outlet body	CC491K	B 62 UNS C83600
2 Inlet body	1.4301	SA 479 Grade 304
3 Valve seal	PTFE / Carbon filled (25%)	
4 Disc	CC493K	SB 505 UNS C93200
5 Guide plate	CC493K	SB 505 UNS C93200
5a Guide plate from GW 1	CW453K	SB 103 UNS C52100
6 Stem	CW453K	SB 103 UNS C52100
7 Spring	1.4571	A 313 Grade 316Ti
8 Bonnet	1.4308	A 351 CF 8
9 Spring clamp	CW614N	B 455 UNS C38500
10 Thread ring	CW614N	B 455 UNS C38500
11 Lifting cap	CW614N	B 455 UNS C38500
12 Lifting spring	1.4571	A 313 Grade 316Ti
13 Lifting stem	CW614N	B 455 UNS C38500
14 Lever	1.4408	A 351 CF8M

Essential: Valves are delivered at a set pressure, therefore when ordering please confirm set pressure, medium and temperature.

Standard marking acc. to Pressure Equipment Directive 97/23/EC (PED) and ASME Code Section VIII.

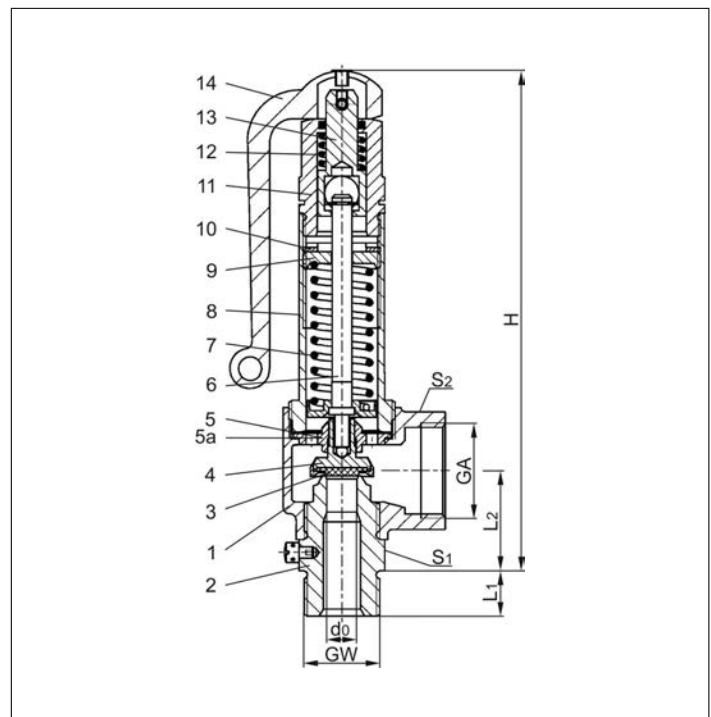

Type 06418	Technical data									
	Nominal size	GW	1/2	3/4	1	1-1/4	1-1/2	2		
Orifice	d_0	7.0	7.0	10.5	10.5	15.0	23.0	23.0	23.0	
Dimension code	.X.	0704	0706	1004	1006	1510	2312	2314	2320	
Set pressure range	bar	3.3-50.0	3.3-50.0	2.9-50.0	2.9-50.0	2.9-50.0	2.0-50.0	2.0-50.0	2.0-50.0	
Outlet	GA	1	1	1	1	1-1/4	2	2	2	
Height	H	175	175	175	175	194	270	270	268	
Length	L_1	14	16	14	16	18	20	20	25	
Length	L_2	36	36	36	36	42	56	56	54	
Wrench size across flats	S_1	30	30	30	30	41	55	55	65	
Wrench size across flats	S_2	41	41	41	41	50	70	70	70	
Weight	ca. kg	1.00	1.02	0.98	1.01	1.52	3.80	3.85	4.28	
Coefficient of discharge	α_w	0.82	0.82	0.58	0.58	0.5	0.62	0.62	0.62	
Coefficient of discharge	rated slope	0.862	0.862	1.517	1.517	2.769	7.55	7.55	7.55	

Dimensions in mm.

Safety Valves

Type 06418



Discharge capacities

Medium:

Air in m³/h at 0°C and 1013.25 mbar

Air in SCFM at 60°F (15.6°C) and 14.7 psia (1013.25 mbar)

The capacity indicated below is for a fully opened valve.

d₀ - orifice

A₀ - flow area

Calculation of discharge capacity acc. to AD2000-Merkblatt A2 / DIN EN ISO 4126-1 resp. ASME Code Sec. VIII.
The safety valve is marked with the lower capacity of both calculations.

Set pressure in bar (g)	GW	1/2 & 3/4	1/2 & 3/4	1	1-1/4, 1-1/2 & 2	Set pressure in psig	GW	1/2 & 3/4	1/2 & 3/4	1	1-1/4, 1-1/2 & 2
	d ₀ (mm)	7.0	10.5	15.0	23.0		d ₀ (inch)	0.276	0.414	0.591	0.907
	A ₀ (mm ²)	38.48	86.6	176.63	415.27		A ₀ (in ²)	0.060	0.134	0.274	0.644
	Medium	Air in m ³ /h					Medium	Air in SCFM			
2.0	-	-	-	-	563	50	60	102	180	524	
2.9	-	143	252	737	60	70	118	208	607		
3.0	-	147	259	756	70	79	134	236	690		
3.3	93	158	279	814	80	89	150	265	772		
4.0	108	185	325	949	90	98	167	294	855		
5.0	130	222	391	1142	100	107	183	322	938		
6.0	153	260	458	1335	110	117	199	350	1021		
7.0	174	298	524	1528	120	126	215	379	1103		
8.0	196	335	590	1721	130	136	231	407	1186		
9.0	219	373	656	1914	140	145	248	435	1269		
10.0	241	410	722	2107	150	155	264	464	1352		
12.0	285	486	855	2493	175	179	304	535	1558		
14.0	330	561	987	2879	200	202	344	606	1766		
16.0	373	636	1119	3265	225	226	384	677	1972		
18.0	418	711	1252	3651	250	250	425	748	2179		
20.0	461	787	1384	4037	275	273	465	818	2386		
22.0	507	862	1517	4422	300	297	506	889	2593		
24.0	550	937	1649	4808	325	321	546	960	2800		
26.0	595	1012	1781	5194	350	345	586	1031	3007		
28.0	638	1088	1914	5580	375	368	626	1102	3213		
30.0	683	1163	2046	5966	400	392	667	1173	3420		
32.0	727	1238	2178	6352	425	416	707	1244	3627		
34.0	772	1313	2311	6738	450	439	748	1315	3834		
36.0	815	1389	2443	7124	475	463	788	1386	4041		
38.0	860	1464	2576	7510	500	487	828	1457	4248		
40.0	904	1539	2708	7896	525	510	869	1528	4455		
42.0	949	1614	2840	8282	550	534	909	1599	4662		
44.0	992	1690	2973	8668	575	558	949	1670	4868		
46.0	1037	1765	3105	9054	625	605	1030	1812	5282		
48.0	1081	1840	3238	9440	675	653	1111	1954	5696		
50.0	1126	1915	3370	9825	725	700	1191	2096	6109		

Safety Valves

Type 06418



Cryogenic Safety Valve, angle type, bronze, PN50, type tested TÜV-SV.780. S/G

Full lift safety valve, orifice $d_0=23\text{mm}$ standard safety valve,
with carbon filled PTFE valve seal, closed bonnet, with lifting device
"cleaned and degreased for oxygen service"

Part No. 06418.X.0040

Inlet: male thread type G (BSPP) acc. to ISO 228/1, Outlet: female thread type G (BSPP) acc. to ISO 228/1

Part No. 06418.X.2040

Inlet: male thread type R (BSPT) acc. to ISO 7/1, Outlet: female thread type G (BSPP) acc. to ISO 228/1

Part No. 06418.X.5040

Inlet: male thread NPT acc. to ANSI B 1.20.1, Outlet: female thread type G (BSPP) acc. to ISO 228/1

Part No. 06418.X.6040

Inlet: male thread NPT acc. to ANSI B 1.20.1, Outlet: female thread NPT acc. to ANSI B 1.20.1

Available options - on request only:

- external parts nickel plated · with installed elbow at the outlet



Applications:

Provided as safety device for protection against excessive pressure in stationary and moveable gas cylinders and pressure vessels. Approved for air gases, vapours and cryogenic liquefied gases incl. LNG.
Working temperature: -196°C / -321°F (77K) up to $+185^\circ\text{C}$ / $+365^\circ\text{F}$ (458K), suitable for horizontal installation

Materials	DIN EN	ASME/ASTM
1 Outlet body	CC491K	B 62 UNS C83600
2 Inlet body	CW614N	B 455 UNS C38500
3 Valve seal	PTFE / Carbon filled (25%)	
4 Disc	CC493K	SB 505 UNS C93200
5 Guide plate	CC493K	SB 505 UNS C93200
5a Guide plate from GW 1	CW453K	SB 103 UNS C52100
6 Stem	CW453K	SB 103 UNS C52100
7 Spring	1.4571	A 313 Grade 316Ti
8 Bonnet	1.4308	A 351 CF 8
9 Spring clamp	CW614N	B 455 UNS C38500
10 Thread ring	CW614N	B 455 UNS C38500
11 Lifting cap	CW614N	B 455 UNS C38500
12 Lifting spring	1.4571	A 313 Grade 316Ti
13 Lifting stem	CW614N	B 455 UNS C38500
14 Lever	1.4408	A 351 CF8M

Essential: Valves are delivered at a set pressure, therefore when ordering please confirm set pressure, medium and temperature.

Standard marking acc. to Pressure Equipment Directive 97/23/EC (PED) and ASME Code Section VIII.

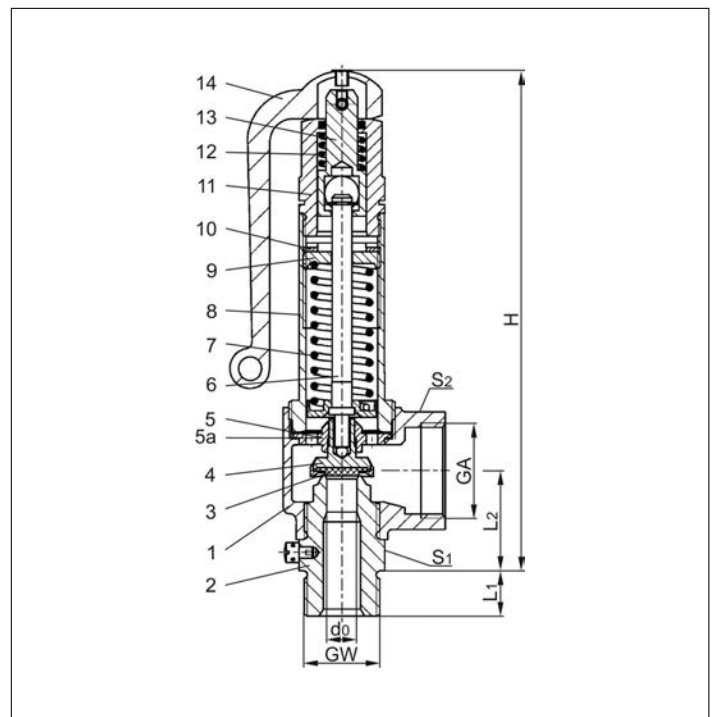

Type 06418	Technical data									
	Nominal size	GW	1/2	3/4	1	1-1/4	1-1/2	2		
Orifice	d_0	7.0	7.0	10.5	10.5	15.0	23.0	23.0	23.0	
Dimension code	.X.	0704	0706	1004	1006	1510	2312	2314	2320	
Set pressure range	bar	3.3-50.0	3.3-50.0	2.9-50.0	2.9-50.0	2.9-50.0	2.0-50.0	2.0-50.0	2.0-50.0	
Outlet	GA	1	1	1	1	1-1/4	2	2	2	
Height	H	175	175	175	175	194	270	270	268	
Length	L_1	14	16	14	16	18	20	20	25	
Length	L_2	36	36	36	36	42	56	56	54	
Wrench size across flats	S_1	30	30	30	30	41	55	55	65	
Wrench size across flats	S_2	41	41	41	41	50	70	70	70	
Weight	ca. kg	1.00	1.02	0.98	1.01	1.52	3.80	3.85	4.28	
Coefficient of discharge	α_w	0.82	0.82	0.58	0.58	0.5	0.62	0.62	0.62	
Coefficient of discharge	rated slope	0.862	0.862	1.517	1.517	2.769	7.55	7.55	7.55	

Dimensions in mm.

Safety Valves

Type 06418



Discharge capacities

Medium:

Air in m³/h at 0°C and 1013.25 mbar

Air in SCFM at 60°F (15.6°C) and 14.7 psia (1013.25 mbar)

The capacity indicated below is for a fully opened valve.

d₀ - orifice

A₀ - flow area

Calculation of discharge capacity acc. to AD2000-Merkblatt A2 / DIN EN ISO 4126-1 resp. ASME Code Sec. VIII.
The safety valve is marked with the lower capacity of both calculations.

Set pressure in bar (g)	GW	1/2 & 3/4	1/2 & 3/4	1	1-1/4, 1-1/2 & 2	Set pressure in psig	GW	1/2 & 3/4	1/2 & 3/4	1	1-1/4, 1-1/2 & 2
	d ₀ (mm)	7.0	10.5	15.0	23.0		d ₀ (inch)	0.276	0.414	0.591	0.907
	A ₀ (mm ²)	38.48	86.6	176.63	415.27		A ₀ (in ²)	0.060	0.134	0.274	0.644
	Medium	Air in m ³ /h					Medium	Air in SCFM			
2.0	-	-	-	-	563	50	60	102	180	524	
2.9	-	143	252	737	60	60	70	118	208	607	
3.0	-	147	259	756	70	70	79	134	236	690	
3.3	93	158	279	814	80	80	89	150	265	772	
4.0	108	185	325	949	90	90	98	167	294	855	
5.0	130	222	391	1142	100	100	107	183	322	938	
6.0	153	260	458	1335	110	110	117	199	350	1021	
7.0	174	298	524	1528	120	120	126	215	379	1103	
8.0	196	335	590	1721	130	130	136	231	407	1186	
9.0	219	373	656	1914	140	140	145	248	435	1269	
10.0	241	410	722	2107	150	150	155	264	464	1352	
12.0	285	486	855	2493	175	175	179	304	535	1558	
14.0	330	561	987	2879	200	200	202	344	606	1766	
16.0	373	636	1119	3265	225	225	226	384	677	1972	
18.0	418	711	1252	3651	250	250	250	425	748	2179	
20.0	461	787	1384	4037	275	275	273	465	818	2386	
22.0	507	862	1517	4422	300	300	297	506	889	2593	
24.0	550	937	1649	4808	325	325	321	546	960	2800	
26.0	595	1012	1781	5194	350	350	345	586	1031	3007	
28.0	638	1088	1914	5580	375	375	368	626	1102	3213	
30.0	683	1163	2046	5966	400	400	392	667	1173	3420	
32.0	727	1238	2178	6352	425	425	416	707	1244	3627	
34.0	772	1313	2311	6738	450	450	439	748	1315	3834	
36.0	815	1389	2443	7124	475	475	463	788	1386	4041	
38.0	860	1464	2576	7510	500	500	487	828	1457	4248	
40.0	904	1539	2708	7896	525	525	510	869	1528	4455	
42.0	949	1614	2840	8282	550	550	534	909	1599	4662	
44.0	992	1690	2973	8668	575	575	558	949	1670	4868	
46.0	1037	1765	3105	9054	625	625	605	1030	1812	5282	
48.0	1081	1840	3238	9440	675	675	653	1111	1954	5696	
50.0	1126	1915	3370	9825	725	725	700	1191	2096	6109	

Safety Valves

Type 06381



Cryogenic Safety Valves, angle type, stainless steel, PN40, type tested TÜV-SV.780. S/G

Standard safety valve

Metal to metal seated, closed bonnet

"cleaned and degreased for oxygen service"

Part No. 06381.X.0000

Inlet: male thread type G (BSPP) acc. to ISO 228/1, Outlet: female thread type G (BSPP) acc. to ISO 228/1

Part No. 06381.X.2000

Inlet: male thread type R (BSPT) acc. to ISO 7/1, Outlet: female thread type G (BSPP) acc. to ISO 228/1

Part No. 06381.X.5000

Inlet: male thread NPT acc. to ANSI B 1.20.1, Outlet: female thread type G (BSPP) acc. to ISO 228/1

Part No. 06381.X.6000

Inlet: male thread NPT acc. to ANSI B 1.20.1, Outlet: female thread NPT acc. to ANSI B 1.20.1



Applications:

Provided as safety device for protection against excessive pressure in stationary and moveable gas cylinders and pressure vessels. Approved for air gases, vapours and cryogenic liquefied gases incl. LNG.

Working temperature: -196°C / -321°F (77K) up to +185°C / +365°F (458K)

Materials	DIN EN	ASME/ASTM
1 Outlet body	1.4308	A 351 CF8
2 Inlet body	1.4301	A 276 Grade 304
4 Disc	1.4541	A 276 Grade 321
5 Guide plate	1.4301	A 276 Grade 304
6 Stem	1.4301	A 276 Grade 304
7 Spring	1.4571	A 313 Grade 316Ti
8 Bonnet	1.4308	A 351 CF8
9 Spring clamp	1.4301	A 276 Grade 304
10 Thread ring	1.4301	A 276 Grade 304
11 Cap	1.4301	A 276 Grade 304

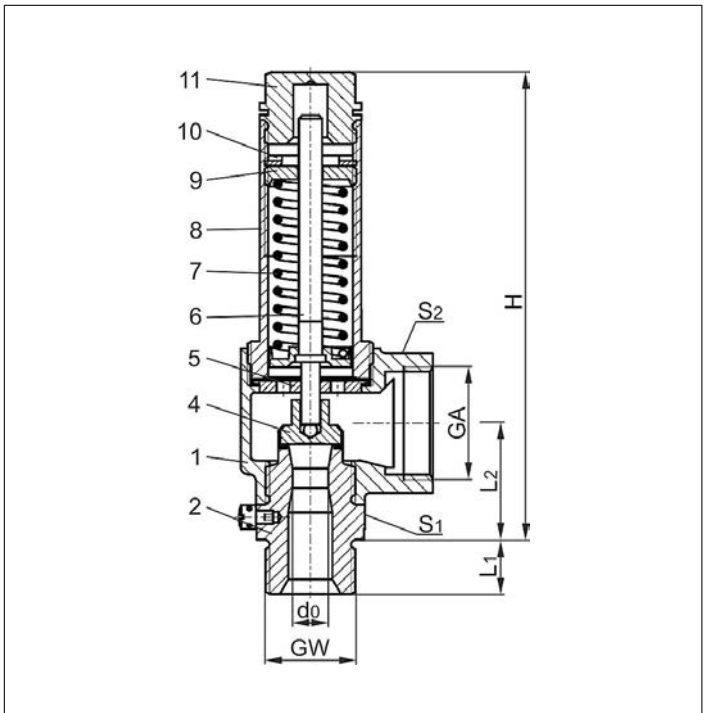

Essential: Valves are delivered at a set pressure, therefore when ordering please confirm set pressure, medium and temperature.

Standard marking acc. to Pressure Equipment Directive 97/23/EC (PED).



Type 06381	Technical data		
Nominal size	GW	1/2	3/4
Orifice	d ₀	10.5	10.5
Dimension code	.X.	1004	1006
Set pressure range	bar	0.2-25.0	0.2-25.0
Outlet	GA	1	1
Height	H	140	140
Length	L ₁	14	16
Length	L ₂	36	36
Wrench size across flats	S ₁	30	30
Wrench size across flats	S ₂	41	41
Weight	ca. kg	0.75	0.78
Coeff. of discharge from 3.0 bar	α _w	0.67	0.67

Dimensions in mm.

Safety Valves

Type 06381



Discharge capacities

Calculation of flow rate acc. to AD2000-Merkblatt A2 / DIN EN ISO 4126-1

Medium:

Air in m³/h at 0°C and 1013.25 mbar

The capacity indicated below is for a fully opened valve.

d_0 - orifice

A_0 - flow area

Set pressure in bar (g)	GW	1/2	3/4
	d_0 (mm)	10.5	10.5
	A_0 (mm ²)	86.6	86.6
	Medium	Air	
0.2		25	25
0.5		48	48
1.0		74	74
1.5		99	99
2.0		123	123
3.0		170	170
4.0		214	214
5.0		258	258
6.0		302	302
7.0		345	345
8.0		390	390
9.0		434	434
10.0		479	479
12.0		566	566
14.0		654	654
16.0		742	742
18.0		830	830
20.0		926	926
22.0		1015	1015
24.0		1103	1103
25.0		1148	1148
26.0		-	-
28.0		-	-
30.0		-	-
32.0		-	-
34.0		-	-
36.0		-	-
38.0		-	-
40.0		-	-

Safety Valves

Type 06383



Cryogenic Safety Valves, angle type, stainless steel, PN50, type tested TÜV-SV.780. S/G

Full lift safety valve, orifice $d_0=23\text{mm}$ standard safety valve,
with carbon filled PTFE valve seal, closed bonnet
"cleaned and degreased for oxygen service"

Part No. 06383.X.0000

Inlet: male thread type G (BSPP) acc. to ISO 228/1, Outlet: female thread type G (BSPP) acc. to ISO 228/1

Part No. 06383.X.2000

Inlet: male thread type R (BSPT) acc. to ISO 7/1, Outlet: female thread type G (BSPP) acc. to ISO 228/1

Part No. 06383.X.5000

Inlet: male thread NPT acc. to ANSI B 1.20.1, Outlet: female thread type G (BSPP) acc. to ISO 228/1

Part No. 06383.X.6000

Inlet: male thread NPT acc. to ANSI B 1.20.1, Outlet: female thread NPT acc. to ANSI B 1.20.1



Applications:

Provided as safety device for protection against excessive pressure in stationary and moveable gas cylinders and pressure vessels. Approved for air gases, vapours and cryogenic liquefied gases incl. LNG.
Working temperature: $-196^\circ\text{C} / -321^\circ\text{F} (77\text{K})$ up to $+185^\circ\text{C} / +365^\circ\text{F} (458\text{K})$, suitable for horizontal installation

Materials	DIN EN	ASME/ASTM
1 Outlet body	1.4308	A 351 CF8
2 Inlet body	1.4301	A 479 Grade 304
3 Valve seal	PTFE / Carbon filled (25%)	
4 Disc	1.4301	A 479 Grade 304
5 Guide plate	1.4301	A 479 Grade 304
6 Stem	1.4301	A 479 Grade 304
7 Spring	1.4571	A 313 Grade 316Ti
8 Bonnet	1.4308	A 351 CF8
9 Spring clamp	1.4301	A 479 Grade 304
10 Thread ring	1.4301	A 479 Grade 304
11 Cap	1.4301	A 479 Grade 304

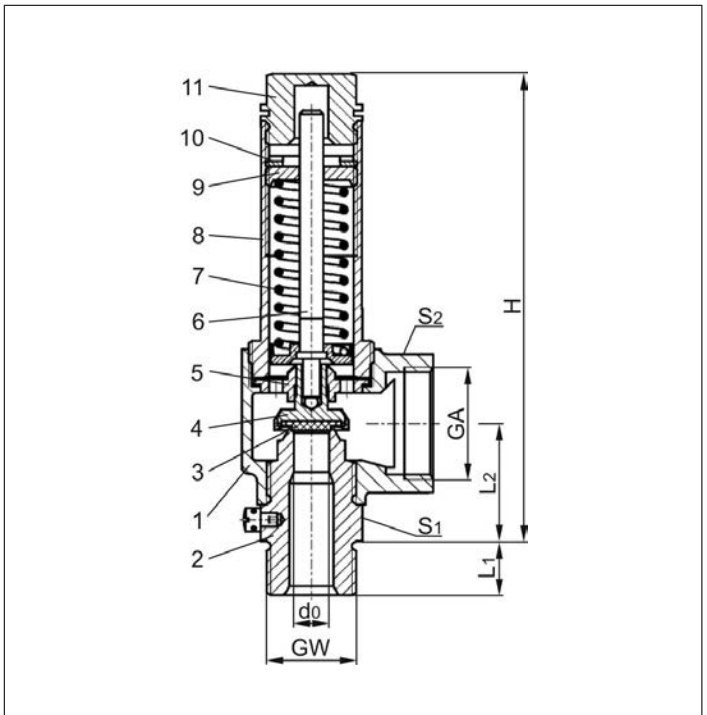

Essential: Valves are delivered at a set pressure, therefore when ordering please confirm set pressure, medium and temperature.

Standard marking acc. to Pressure Equipment Directive 97/23/EC (PED) and ASME Code Section VIII.



Type 06383	Technical data									
	Nominal size	GW	1/2	3/4	1	1-1/4	1-1/2	2	2	2
Orifice	d_0	7.0	7.0	10.5	10.5	15.0	23.0	23.0	23.0	23.0
Dimension code	.X.	0704	0706	1004	1006	1510	2312	2314	2320	2320
Set pressure range	bar	3.3-50.0	3.3-50.0	2.9-50.0	2.9-50.0	2.9-50.0	2.0-50.0	2.0-50.0	2.0-50.0	2.0-50.0
Outlet	GA	1	1	1	1	1-1/4	2	2	2	2
Height	H	140	140	140	140	157	218	218	218	216
Length	L_1	14	16	14	16	18	20	20	20	25
Length	L_2	36	36	36	36	42	56	56	56	54
Wrench size across flats	S_1	30	30	30	30	41	55	55	55	65
Wrench size across flats	S_2	41	41	41	41	50	70	70	70	70
Weight	ca. kg	0.78	0.80	0.76	0.79	1.27	3.05	3.10	3.10	3.30
Coefficient of discharge	α_w	0.82	0.82	0.58	0.58	0.5	0.62	0.62	0.62	0.62
Coefficient of discharge	rated slope	0.862	0.862	1.517	1.517	2.769	7.55	7.55	7.55	7.55

Dimensions in mm.

Safety Valves

Type 06383



Discharge capacities

Medium:

Air in m³/h at 0°C and 1013.25 mbar

Air in SCFM at 60°F (15.6°C) and 14.7 psia (1013.25 mbar)

The capacity indicated below is for a fully opened valve.

d₀ - orifice

A₀ - flow area

Calculation of discharge capacity acc. to AD2000-Merkblatt A2 / DIN EN ISO 4126-1 resp. ASME Code Sec. VIII.

The safety valve is marked with the lower capacity of both calculations.

Set pressure in bar (g)	GW	1/2 & 3/4	1/2 & 3/4	1	1-1/4, 1-1/2 & 2	Set pressure in psig	GW	1/2 & 3/4	1/2 & 3/4	1	1-1/4, 1-1/2 & 2
	d ₀ (mm)	7.0	10.5	15.0	23.0		d ₀ (inch)	0.276	0.414	0.591	0.907
	A ₀ (mm ²)	38.48	86.6	176.63	415.27		A ₀ (in ²)	0.060	0.134	0.274	0.644
	Medium	Air in m ³ /h					Medium	Air in SCFM			
2.0	-	-	-	-	563	50	60	102	180	524	
2.9	-	143	252	737	60	60	70	118	208	607	
3.0	-	147	259	756	70	70	79	134	236	690	
3.3	93	158	279	814	80	80	89	150	265	772	
4.0	108	185	325	949	90	90	98	167	294	855	
5.0	130	222	391	1142	100	100	107	183	322	938	
6.0	153	260	458	1335	110	110	117	199	350	1021	
7.0	174	298	524	1528	120	120	126	215	379	1103	
8.0	196	335	590	1721	130	130	136	231	407	1186	
9.0	219	373	656	1914	140	140	145	248	435	1269	
10.0	241	410	722	2107	150	150	155	264	464	1352	
12.0	285	486	855	2493	175	175	179	304	535	1558	
14.0	330	561	987	2879	200	200	202	344	606	1766	
16.0	373	636	1119	3265	225	225	226	384	677	1972	
18.0	418	711	1252	3651	250	250	250	425	748	2179	
20.0	461	787	1384	4037	275	275	273	465	818	2386	
22.0	507	862	1517	4422	300	300	297	506	889	2593	
24.0	550	937	1649	4808	325	325	321	546	960	2800	
26.0	595	1012	1781	5194	350	350	345	586	1031	3007	
28.0	638	1088	1914	5580	375	375	368	626	1102	3213	
30.0	683	1163	2046	5966	400	400	392	667	1173	3420	
32.0	727	1238	2178	6352	425	425	416	707	1244	3627	
34.0	772	1313	2311	6738	450	450	439	748	1315	3834	
36.0	815	1389	2443	7124	475	475	463	788	1386	4041	
38.0	860	1464	2576	7510	500	500	487	828	1457	4248	
40.0	904	1539	2708	7896	525	525	510	869	1528	4455	
42.0	949	1614	2840	8282	550	550	534	909	1599	4662	
44.0	992	1690	2973	8668	575	575	558	949	1670	4868	
46.0	1037	1765	3105	9054	625	625	605	1030	1812	5282	
48.0	1081	1840	3238	9440	675	675	653	1111	1954	5696	
50.0	1126	1915	3370	9825	725	725	700	1191	2096	6109	

Safety Valves

Type 06413

HEROSE



Cryogenic Safety Valves, angle type, stainless steel, PN50, type tested TÜV-SV.780. S/G

Full lift safety valve, orifice $d_0=23\text{mm}$ standard safety valve, with carbon filled PTFE valve seal, closed bonnet, with lifting device "cleaned and degreased for oxygen service"

Part No. 06413.X.0000

Inlet: male thread type G (BSPP) acc. to ISO 228/1, Outlet: female thread type G (BSPP) acc. to ISO 228/1

Part No. 06413.X.2000

Inlet: male thread type R (BSPT) acc. to ISO 7/1, Outlet: female thread type G (BSPP) acc. to ISO 228/1

Part No. 06413.X.5000

Inlet: male thread NPT acc. to ANSI B 1.20.1, Outlet: female thread type G (BSPP) acc. to ISO 228/1

Part No. 06413.X.6000

Inlet: male thread NPT acc. to ANSI B 1.20.1, Outlet: female thread NPT acc. to ANSI B 1.20.1



Applications:

Provided as safety device for protection against excessive pressure in stationary and moveable gas cylinders and pressure vessels. Approved for air gases, vapours and cryogenic liquefied gases incl. LNG. Working temperature: $-196^\circ\text{C} / -321^\circ\text{F}$ (77K) up to $+185^\circ\text{C} / +365^\circ\text{F}$ (458K), suitable for horizontal installation

Materials	DIN EN	ASME/ASTM
1 Outlet body	1.4308	A 351 CF8
2 Inlet body	1.4301	A 479 Grade 304
3 Valve seal	PTFE / Carbon filled (25%)	
4 Disc	1.4301	A 479 Grade 304
5 Guide plate	1.4301	A 479 Grade 304
5a Guide plate from GW 1	1.4301	A 479 Grade 304
6 Stem	1.4571	A 479 Grade 316Ti
7 Spring	1.4571	A 313 Grade 316Ti
8 Bonnet	1.4308	A 351 CF8
9 Spring clamp	1.4301	A 479 Grade 304
10 Thread ring	1.4301	A 479 Grade 304
11 Lifting cap	1.4301	A 479 Grade 304
12 Lifting spring	1.4571	A 313 Grade 316Ti
13 Lifting stem	1.4301	A 479 Grade 304
14 Lever	1.4408	A 351 CF8M

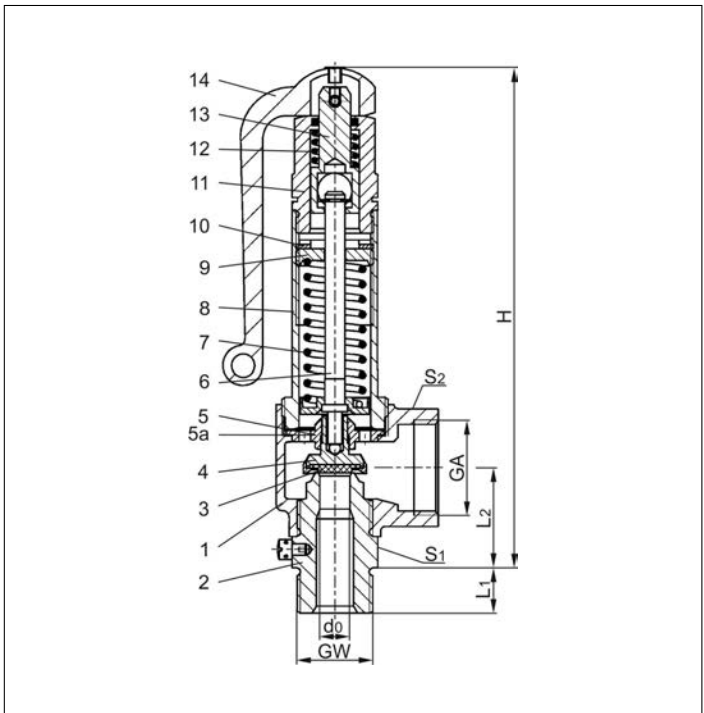

Essential: Valves are delivered at a set pressure, therefore when ordering please confirm set pressure, medium and temperature.

Standard marking acc. to Pressure Equipment Directive 97/23/EC (PED) and ASME Code Section VIII.



Type 06413	Technical data								
	GW	1/2	3/4	1	1-1/4	1-1/2	2	2	2
Nominal size	GW	1/2	3/4	1	1-1/4	1-1/2	2	2	2
Orifice	d_0	7.0	7.0	10.5	10.5	15.0	23.0	23.0	23.0
Dimension code	.X.	0704	0706	1004	1006	1510	2312	2314	2320
Set pressure range	bar	3.3-50.0	3.3-50.0	2.9-50.0	2.9-50.0	2.9-50.0	2.0-50.0	2.0-50.0	2.0-50.0
Outlet	GA	1	1	1	1	1-1/4	2	2	2
Height	H	175	175	175	175	194	270	270	268
Length	L_1	14	16	14	16	18	20	20	25
Length	L_2	36	36	36	36	42	56	56	54
Wrench size across flats	S_1	30	30	30	30	41	55	55	65
Wrench size across flats	S_2	41	41	41	41	50	70	70	70
Weight	ca. kg	1.00	1.02	0.98	1.01	1.52	3.80	3.85	4.28
Coefficient of discharge	α_w	0.82	0.82	0.58	0.58	0.5	0.62	0.62	0.62
Coefficient of discharge	rated slope	0.862	0.862	1.517	1.517	2.769	7.55	7.55	7.55

Dimensions in mm.

Safety Valves

Type 06413



Discharge capacities

Medium:

Air in m³/h at 0°C and 1013.25 mbar

Air in SCFM at 60°F (15.6°C) and 14.7 psia (1013.25 mbar)

The capacity indicated below is for a fully opened valve.

d₀ - orifice

A₀ - flow area

Calculation of discharge capacity acc. to AD2000-Merkblatt A2 / DIN EN ISO 4126-1 resp. ASME Code Sec. VIII.

The safety valve is marked with the lower capacity of both calculations.

Set pressure in bar (g)	GW	1/2 & 3/4	1/2 & 3/4	1	1-1/4, 1-1/2 & 2	Set pressure in psig	GW	1/2 & 3/4	1/2 & 3/4	1	1-1/4, 1-1/2 & 2
	d ₀ (mm)	7.0	10.5	15.0	23.0		d ₀ (inch)	0.276	0.414	0.591	0.907
	A ₀ (mm ²)	38.48	86.6	176.63	415.27		A ₀ (in ²)	0.060	0.134	0.274	0.644
	Medium	Air in m ³ /h					Medium	Air in SCFM			
2.0		-	-	-	563	50		60	102	180	524
2.9		-	143	252	737	60		70	118	208	607
3.0		-	147	259	756	70		79	134	236	690
3.3		93	158	279	814	80		89	150	265	772
4.0		108	185	325	949	90		98	167	294	855
5.0		130	222	391	1142	100		107	183	322	938
6.0		153	260	458	1335	110		117	199	350	1021
7.0		174	298	524	1528	120		126	215	379	1103
8.0		196	335	590	1721	130		136	231	407	1186
9.0		219	373	656	1914	140		145	248	435	1269
10.0		241	410	722	2107	150		155	264	464	1352
12.0		285	486	855	2493	175		179	304	535	1558
14.0		330	561	987	2879	200		202	344	606	1766
16.0		373	636	1119	3265	225		226	384	677	1972
18.0		418	711	1252	3651	250		250	425	748	2179
20.0		461	787	1384	4037	275		273	465	818	2386
22.0		507	862	1517	4422	300		297	506	889	2593
24.0		550	937	1649	4808	325		321	546	960	2800
26.0		595	1012	1781	5194	350		345	586	1031	3007
28.0		638	1088	1914	5580	375		368	626	1102	3213
30.0		683	1163	2046	5966	400		392	667	1173	3420
32.0		727	1238	2178	6352	425		416	707	1244	3627
34.0		772	1313	2311	6738	450		439	748	1315	3834
36.0		815	1389	2443	7124	475		463	788	1386	4041
38.0		860	1464	2576	7510	500		487	828	1457	4248
40.0		904	1539	2708	7896	525		510	869	1528	4455
42.0		949	1614	2840	8282	550		534	909	1599	4662
44.0		992	1690	2973	8668	575		558	949	1670	4868
46.0		1037	1765	3105	9054	625		605	1030	1812	5282
48.0		1081	1840	3238	9440	675		653	1111	1954	5696
50.0		1126	1915	3370	9825	725		700	1191	2096	6109

Safety Valves

Type 06420



Cryogenic Safety Valves, angle type, bronze, PN40

$d_0=7.0$ & 10.5mm up to PN50

type tested TÜV-SV.1111. S/G

Standard safety valve,

with PCTFE valve seal, (D_07 = Metal to metal seated), closed bonnet

"cleaned and degreased for oxygen service"

Part No. 06420.X.0000

Inlet: male thread type G (BSPP) acc. to ISO 228/1, Outlet: female thread type G (BSPP) acc. to ISO 228/1

Part No. 06420.X.2000

Inlet: male thread type R (BSPT) acc. to ISO 7/1, Outlet: female thread type G (BSPP) acc. to ISO 228/1

Part No. 06420.X.5000

Inlet: male thread NPT acc. to ANSI B 1.20.1, Outlet: female thread type G (BSPP) acc. to ISO 228/1

Part No. 06420.X.6000

Inlet: male thread NPT acc. to ANSI B 1.20.1, Outlet: female thread NPT acc. to ANSI B 1.20.1



Applications:

Provided as safety device for protection against excessive pressure in stationary and moveable gas cylinders and pressure vessels. Approved for air gases, vapours and cryogenic liquefied gases incl. LNG.

Working temperature: -196°C / -321°F (77K) up to $+185^\circ\text{C}$ / $+365^\circ\text{F}$ (458K), with PCTFE-seal up to $+150^\circ\text{C}$ / 302°F (423K), suitable for horizontal installation

Materials	DIN EN	ASME/ASTM
1 Outlet body	CC491K	SB62 UNS C83600
2 Inlet body	1.4301	SA 479 Grade 304
3 Valve seal	PCTFE	
4 Disc	CC493K	B 505 UNS C93200
5 Guide plate	CC493K	B 505 UNS C93200
6 Stem	CW453K	B 103 UNS C52100
7 Spring	1.4571	A 313 Grade 316Ti
8 Bonnet	1.4301	A 276 Grade 304
9 Spring clamp	CW614N	B 455 UNS C38500
10 Thread ring	CW614N	B 455 UNS C38500
11 Cap	CW614N	B 455 UNS C38500

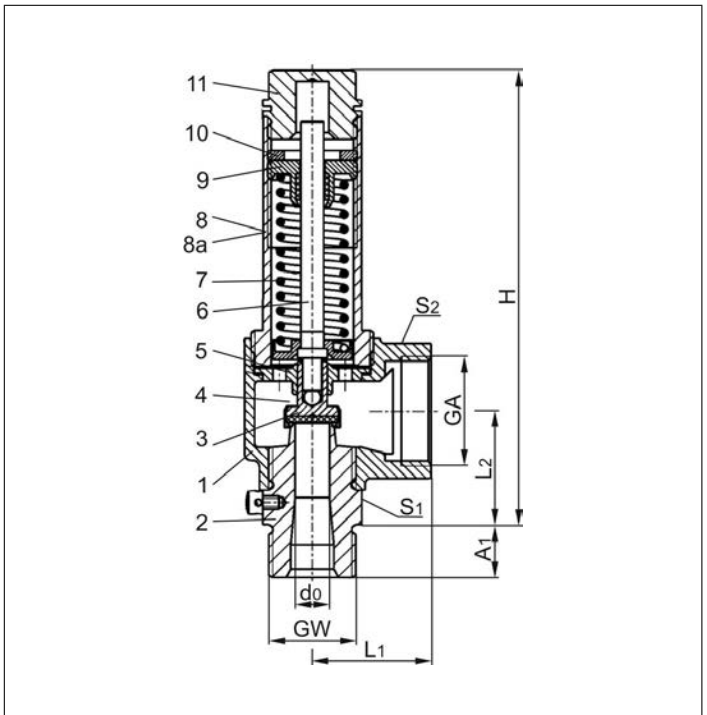

Essential: Valves are delivered at a set pressure, therefore when ordering please confirm set pressure, medium and temperature.

Standard marking acc. to Pressure Equipment Directive 97/23/EC (PED).



Type 06420	Technical data									
Nominal size	GW	1/2	3/4	1/2	3/4	3/4	1	1	1-1/4	1-1/4
Orifice	d_0	7.0	7.0	10.5	10.5	14.0	14.0	18.0	18.0	23.0
Dimension code	.X.	0704	0706	1004	1006	1406	1410	1810	1812	2312
Set pressure range	bar	0.4-50.0	0.4-50.0	0.4-50.0	0.4-50.0	0.4-40.0	0.4-40.0	0.4-40.0	0.4-40.0	0.4-10.0
Outlet	GA	1	1	1	1	1-1/4	1-1/4	1-1/2	1-1/2	1-1/2
Height	H	140	140	140	140	159	159	186	187	187
Length	A_1	14	16	14	16	16	18	18	20	20
Length	L_1	36	36	36	36	50	50	48	48	48
Length	L_2	36.5	36.5	36.5	34.5	44	44	50.5	51.5	52
Wrench size across flats	S_1	30	30	30	30	41	41	50	50	50
Wrench size across flats	S_2	41	41	41	41	50	50	58	58	58
Weight	ca. kg	0.78	0.80	0.76	0.79	1.25	1.31	1.87	1.99	1.90
Coeff. of disch. from 3.0 bar	α_w	0.78	0.78	0.69	0.69	0.66	0.66	0.66	0.66	0.54

Dimensions in mm.

Safety Valves

Type 06420



Discharge capacities

Calculation of flow rate acc. to AD2000-Merkblatt A2 / DIN EN ISO 4126-1

Medium:

Air in m³/h at 0°C and 1013.25 mbar

The capacity indicated below is for a fully opened valve.

d₀ - orifice

A₀ - flow area

Set pressure in bar (g)	GW	1/2 & 3/4	1/2 & 3/4	3/4 & 1	1 & 1-1/4	1-1/4
	d ₀ (mm)	7.0	10.5	14.0	18.0	23.0
	A ₀ (mm ²)	38.48	86.6	153.9	254.5	415.3
	Medium	Air				
0.4		24	43	77	122	157
0.5		27	49	87	141	178
1.0		40	77	130	216	287
1.5		54	101	178	290	375
2.0		65	126	219	362	472
3.0		88	175	299	494	660
4.0		110	220	375	620	829
5.0		133	266	452	748	999
6.0		156	311	529	874	1168
7.0		178	356	605	1001	1337
8.0		202	402	684	1130	1510
9.0		224	447	760	1257	1680
10.0		247	493	839	1387	1853
12.0		293	583	992	1641	-
14.0		338	674	1146	1895	-
16.0		384	764	1300	2149	-
18.0		429	855	1453	2403	-
20.0		479	954	1623	2682	-
22.0		525	1045	1778	2939	-
24.0		571	1136	1933	3195	-
26.0		617	1228	2088	3452	-
28.0		662	1319	2243	3708	-
30.0		715	1423	2421	4002	-
32.0		761	1516	2577	4261	-
34.0		807	1608	2734	4520	-
36.0		854	1700	2891	4779	-
38.0		900	1792	3047	5038	-
40.0		954	1900	3231	5342	-
42.0		1001	1993	-	-	-
44.0		1048	2086	-	-	-
46.0		1094	2179	-	-	-
48.0		1141	2272	-	-	-
50.0		1198	2385	-	-	-

Safety Valves

Type 06425



Cryogenic Safety Valves, angle type, bronze, PN40

$d_0=7.0$ & 10.5 mm up to PN50, type tested TÜV-SV.1111. S/G

Standard safety valve,

with PCTFE valve seal (D_07 = Metal to metal seated [Part No.- last three digits: **100**],

D_010 = Metal to metal seated below 3.0 bar), closed bonnet, with lifting device

"cleaned and degreased for oxygen service"

Part No. 06425.X.0000

Inlet: male thread type G (BSPP) acc. to ISO 228/1, Outlet: female thread type G (BSPP) acc. to ISO 228/1

Part No. 06425.X.2000

Inlet: male thread type R (BSPT) acc. to 7/1, Outlet: female thread type G (BSPP) acc. to ISO 228/1

Part No. 06425.X.5000

Inlet: male thread NPT acc. to ANSI B 1.20.1, Outlet: female thread type G (BSPP) acc. to ISO 228/1

Part No. 06425.X.6000

Inlet: male thread NPT acc. to ANSI B 1.20.1, Outlet: female thread NPT acc. to ANSI B 1.20.1



Applications:

Provided as safety device for protection against excessive pressure in stationary and moveable gas cylinders and pressure vessels. Approved for air gases, vapours and cryogenic liquefied gases incl. LNG.

Working temperature: -196°C / -321°F (77K) up to $+185^{\circ}\text{C}$ / $+365^{\circ}\text{F}$ (458K), with PCTFE-seal up to $+150^{\circ}\text{C}$ / 302°F (423K), suitable for horizontal installation

Materials	DIN EN	ASME/ASTM
1 Outlet body	CC491K	SB 62 UNS C83600
2 Inlet body	1.4301	SA 479 Grade 304
3 Valve seal	PCTFE	
4 Disc	CC493K	B 505 UNS C93200
5 Guide plate	CC493K	B 505 UNS C93200
6 Stem	CW453K	B 103 UNS C52100
7 Spring	1.4571	A 313 Grade 316Ti
8 Bonnet	1.4301	A 276 Grade 304
9 Spring clamp	CW614N	B 455 UNS C38500
10 Thread ring	CW614N	B 455 UNS C38500
11 Lifting cap	CW614N	B 455 UNS C38500
12 Lifting spring	1.4571	A 313 Grade 316Ti
13 Lifting stem	CW614N	B 455 UNS C38500
14 Lever	1.4408	SA351 CF8M

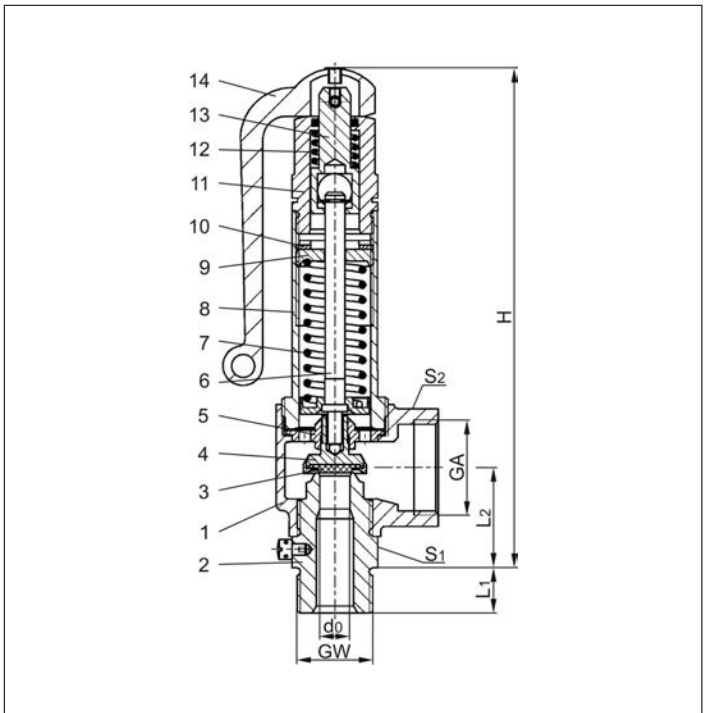

Essential: Valves are delivered at a set pressure, therefore when ordering please confirm set pressure, medium and temperature.

Standard marking acc. to Pressure Equipment Directive 97/23/EC (PED).



Type 06425	Technical data									
	GW	1/2	3/4	1/2	3/4	3/4	1	1	1-1/4	1-1/4
Nominal size	d_0	7.0	7.0	10.5	10.5	14.0	14.0	18.0	18.0	23.0
Dimension code	.X.	0704	0706	1004	1006	1406	1410	1810	1812	2312
Set pressure range	bar	0.4-50.0	0.4-50.0	0.4-50.0	0.4-50.0	0.4-40.0	0.4-40.0	0.4-40.0	0.4-40.0	0.4-10.0
Outlet	GA	1	1	1	1	1-1/4	1-1/4	1-1/2	1-1/2	1-1/2
Height	H	176	176	176	176	196	196	239	240	239
Length	A_1	14	16	14	16	16	18	18	20	20
Length	L_1	36	36	36	36	50	50	48	48	48
Length	L_2	36.5	36.5	36.5	34.5	44	44	50.5	51.5	52
Wrench size across flats	S_1	30	30	30	30	41	41	50	50	50
Wrench size across flats	S_2	41	41	41	41	50	50	58	58	58
Weight	ca. kg	1.00	1.02	0.98	1.01	1.50	1.56	2.51	2.63	2.52
Coeff. of disch. from 3.0 bar	α_w	0.78	0.78	0.69	0.69	0.66	0.66	0.66	0.66	0.54

Dimensions in mm.

Safety Valves

Type 06425



Discharge capacities

Calculation of flow rate acc. to AD2000-Merkblatt A2 / DIN EN ISO 4126-1

Medium:

Air in m³/h at 0°C and 1013.25 mbar

The capacity indicated below is for a fully opened valve.

d₀ - orifice

A₀ - flow area

Set pressure in bar (g)	GW	1/2 & 3/4	1/2 & 3/4	3/4 & 1	1 & 1-1/4	1-1/4
	d ₀ (mm)	7.0	10.5	14.0	18.0	23.0
	A ₀ (mm ²)	38.48	86.6	153.9	254.5	415.3
	Medium	Air				
0.4		24	43	77	122	157
0.5		27	49	87	141	178
1.0		40	77	130	216	287
1.5		54	101	178	290	375
2.0		65	126	219	362	472
3.0		88	175	299	494	660
4.0		110	220	375	620	829
5.0		133	266	452	748	999
6.0		156	311	529	874	1168
7.0		178	356	605	1001	1337
8.0		202	402	684	1130	1510
9.0		224	447	760	1257	1680
10.0		247	493	839	1387	1853
12.0		293	583	992	1641	-
14.0		338	674	1146	1895	-
16.0		384	764	1300	2149	-
18.0		429	855	1453	2403	-
20.0		479	954	1623	2682	-
22.0		525	1045	1778	2939	-
24.0		571	1136	1933	3195	-
25.0		594	1182	2010	3324	-
26.0		617	1228	2088	3452	-
28.0		662	1319	2243	3708	-
30.0		715	1423	2421	4002	-
32.0		761	1516	2577	4261	-
34.0		807	1608	2734	4520	-
36.0		854	1700	2891	4779	-
38.0		900	1792	3047	5038	-
40.0		954	1900	3231	5342	-
42.0		1001	1993	-	-	-
44.0		1048	2086	-	-	-
46.0		1094	2179	-	-	-
48.0		1141	2272	-	-	-
50.0		1198	2385	-	-	-

Safety Valves

Type 06421



Cryogenic Safety Valves, angle type, bronze, PN40
 $d_0=7,0$ & $10,5$ mm up to PN50,
 type tested TÜV-SV.1111. S/G

Standard safety valve,
 with PCTFE valve seal (D_07 = Metal to metal seated), closed bonnet
 "cleaned and degreased for oxygen service"

Part No. 06421.X.0000

Inlet: female thread type G (BSPP) acc. to ISO 228/1
 Outlet: female thread type G (BSPP) acc. to ISO 228/1



Applications:

Provided as safety device for protection against excessive pressure in stationary and moveable gas cylinders and pressure vessels. Approved for air gases, vapours and cryogenic liquefied gases incl. LNG.
 Working temperature: -196°C / -321°F (77K) up to $+185^{\circ}\text{C}$ / $+365^{\circ}\text{F}$ (458K), with PCTFE-seal up to $+150^{\circ}\text{C}$ / 302°F (423K), suitable for horizontal installation

Materials	DIN EN	ASME/ASTM
1 Outlet body	CC491K	SB 62 UNS C83600
2 Inlet body	1.4301	SA 479 Grade 304
3 Vasal seal	PCTFE	
4 Disc	CC493K	B 505 UNS C93200
5 Guide plate	CW493K	B 505 UNS C93200
6 Stem	CW453K	B 103 UNS C52100
7 Spring	1.4571	A 313 Grade 316Ti
8 Bonnet	1.4301	A 276 Grade 304
9 Spring clamp	CW614N	B 455 UNS C38500
10 Thread ring	CW614N	B 455 UNS C38500
11 Cap	CW614N	B 455 UNS C38500

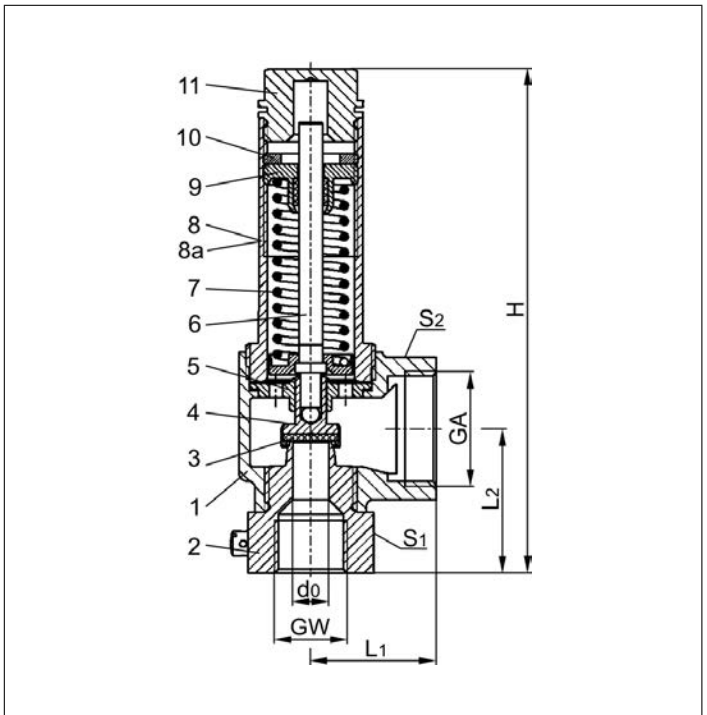

Essential: Valves are delivered at a set pressure, therefore when ordering please confirm set pressure, medium and temperature.

Standard marking acc. to Pressure Equipment Directive 97/23/EC (PED).



Type 06421	Technical data					
Nominal size	GW	1/2	1/2	3/4	1	1-1/4
Orifice	d_0	7.0	10.5	14.0	18.0	23.0
Dimension Code	.X.	0704	1004	1406	1810	2312
Set pressure range	bar	0.4-50.0	0.4-50.0	0.4-40.0	0.4-40.0	0.4-10.0
Outlet	GA	1	1	1-1/4	1-1/2	1-1/2
Height	H	145	145	164	195	200
Length	L_1	36	36	50	48	48
Length	L_2	41.5	41.5	49	59.5	65
Wrench size across flats	S_1	36	36	41	50	50
Wrench size across flats	S_2	41	41	50	58	58
Weight	ca. kg	0.80	0.795	1.25	1.87	1.79
Coeff. of discharge from 3.0 bar	α_w	0.78	0.69	0.66	0.66	0.54

Dimensions in mm.

Safety Valves

Type 06421



Discharge capacities

Calculation of flow rate acc. to AD2000-Merkblatt A2 / DIN EN ISO 4126-1

Medium:

Air in m³/h at 0°C and 1013.25 mbar

The capacity indicated below is for fully opened valve.

d₀ - orifice

A₀ - flow area

Set pressure in bar (g)	GW	1/2	1/2	3/4	1	1-1/4
	d ₀ (mm)	7.0	10.5	14.0	18.0	23.0
A ₀ (mm ²)	38.48	86.6	153.9	254.5	415.3	
Medium	Air					
0.4		24	43	77	122	157
0.5		27	49	87	141	178
1.0		40	77	130	216	287
1.5		54	101	178	290	375
2.0		65	126	219	362	472
3.0		88	175	299	494	660
4.0		110	220	375	620	829
5.0		133	266	452	748	999
6.0		156	311	529	874	1168
7.0		178	356	605	1001	1337
8.0		202	402	684	1130	1510
9.0		224	447	760	1257	1680
10.0		247	493	839	1387	1853
12.0		293	583	992	1641	-
14.0		338	674	1146	1895	-
16.0		384	764	1300	2149	-
18.0		429	855	1453	2403	-
20.0		479	954	1623	2682	-
22.0		525	1045	1778	2939	-
24.0		571	1136	1933	3195	-
25.0		594	1182	2010	3324	-
26.0		617	1228	2088	3452	-
28.0		662	1319	2243	3708	-
30.0		715	1423	2421	4002	-
32.0		761	1516	2577	4261	-
34.0		807	1608	2734	4520	-
36.0		854	1700	2891	4779	-
38.0		900	1792	3047	5038	-
40.0		954	1900	3231	5342	-
42.0		1001	1993	-	-	-
44.0		1048	2086	-	-	-
46.0		1094	2179	-	-	-
48.0		1141	2272	-	-	-
50.0		1198	2385	-	-	-

Safety Valves

Type 06426



Cryogenic Safety Valves, angle type, bronze, PN40
 $d_0=7,0$ & $10,5$ mm up to PN50,
 type tested TÜV-SV.1111. S/G

Standard safety valve,
 with PCTFE valve seal (D_07 = Metal to metal seated), closed bonnet, with lifting device
 "cleaned and degreased for oxygen service"

Part No. 06426.X.0000

Inlet: female thread type G (BSPP) acc. to ISO 228/1
 Outlet: female thread type G (BSPP) acc. to ISO 228/1

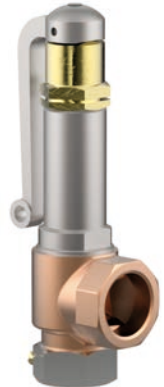

Applications:

Provided as safety device for protection against excessive pressure in stationary and moveable gas cylinders and pressure vessels. Approved for air gases, vapours and cryogenic liquefied gases incl. LNG.
 Working temperature: -196°C / -321°F (77K) up to $+185^{\circ}\text{C}$ / $+365^{\circ}\text{F}$ (458K), with PCTFE-seal up to $+150^{\circ}\text{C}$ / 302°F (423K), suitable for horizontal installation

Materials	DIN EN	ASME/ASTM
1 Outlet body	CC491K	SB 62 UNS C83600
2 Inlet body	1.4301	SA 479 Grade 304
3 Valve seal	PCTFE	
4 Disc	CC493K	B 505 UNS C93200
5 Guide plate	CC493K	B 505 UNS C93200
6 Stem	CW453K	B 103 UNS C52100
7 Spring	1.4571	A 313 Grade 316Ti
8 Bonnet	1.4301	A 276 Grade 304
9 Spring clamp	CW614N	B 455 UNS C38500
10 Thread ring	CW614N	B 455 UNS C38500
11 Lifting cap	CW614N	B 455 UNS C38500
12 Lifting spring	1.4571	A 313 Grade 316Ti
13 Lifting stem	CW614N	B 455 UNS C38500
14 Lever	1.4408	SA351 CF8M

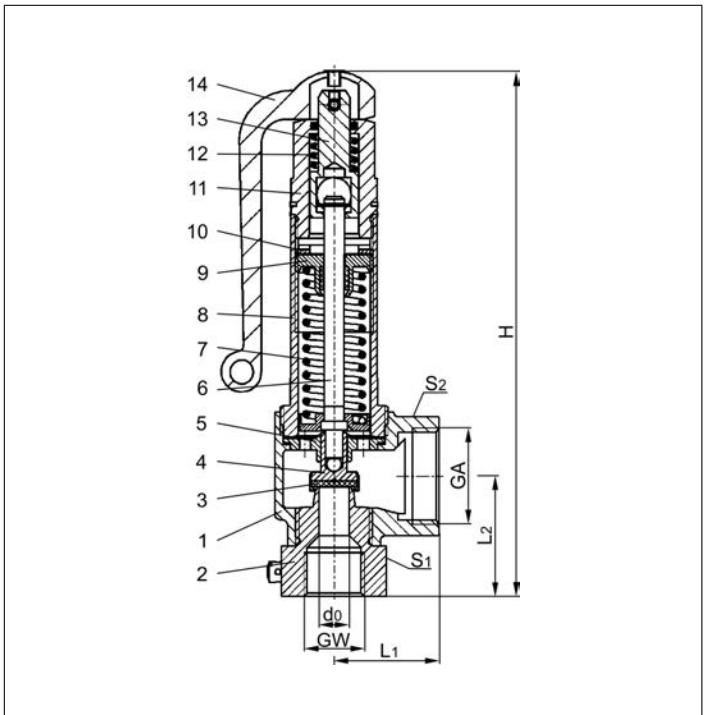

Essential: Valves are delivered at a set pressure, therefore when ordering please confirm set pressure, medium and temperature.

Standard marking acc. to Pressure Equipment Directive 97/23/EC (PED).



Type 06426	Technical Data						
	Nominal size	GW	1/2	1/2	3/4	1	1-1/4
Orifice	d_0	7.0	10.5	14.0	18.0	23.0	
Dimension code	.X.	0704	1004	1406	1810	2312	
Set pressure range	bar	0.4-50.0	0.4-50.0	0.4-40.0	0.4-40.0	0.4-10.0	
Outlet	GA	1	1	1-1/4	1-1/2	1-1/2	
Height	H	181	181	201	247	252	
Length	L_1	36	36	50	48	48	
Length	L_2	41.5	41.5	49	59.5	65	
Wrench size across flats	S_1	36	36	41	50	50	
Wrench size across flats	S_2	41	41	50	58	58	
Weight	ca. kg	1.02	1.01	1.50	2.45	2.40	
Coeff. of discharge from 3.0 bar	α_w	0.78	0.69	0.66	0.66	0.54	

Dimensions in mm.

Safety Valves

Type 06426



Discharge capacities

Calculation of flow rate acc. to AD2000-Merkblatt A2 / DIN EN ISO 4126-1

Medium:

Air in m³/h at 0°C and 1013.25 mbar

The capacity indicated below is for fully opened valve.

d₀ - orifice

A₀ - flow area

Set pressure in bar (g)	GW	1/2	1/2	3/4	1	1-1/4
	d ₀ (mm)	7.0	10.5	14.0	18.0	23.0
A ₀ (mm ²)	38.48	86.6	153.9	254.5	415.3	
Medium	Air					
0.4		24	43	77	122	157
0.5		27	49	87	141	178
1.0		40	77	130	216	287
1.5		54	101	178	290	375
2.0		65	126	219	362	472
3.0		88	175	299	494	660
4.0		110	220	375	620	829
5.0		133	266	452	748	999
6.0		156	311	529	874	1168
7.0		178	356	605	1001	1337
8.0		202	402	684	1130	1510
9.0		224	447	760	1257	1680
10.0		247	493	839	1387	1853
12.0		293	583	992	1641	-
14.0		338	674	1146	1895	-
16.0		384	764	1300	2149	-
18.0		429	855	1453	2403	-
20.0		479	954	1623	2682	-
22.0		525	1045	1778	2939	-
24.0		571	1136	1933	3195	-
25.0		594	1182	2010	3324	-
26.0		617	1228	2088	3452	-
28.0		662	1319	2243	3708	-
30.0		715	1423	2421	4002	-
32.0		761	1516	2577	4261	-
34.0		807	1608	2734	4520	-
36.0		854	1700	2891	4779	-
38.0		900	1792	3047	5038	-
40.0		954	1900	3231	5342	-
42.0		1001	1993	-	-	-
44.0		1048	2086	-	-	-
46.0		1094	2179	-	-	-
48.0		1141	2272	-	-	-
50.0		1198	2385	-	-	-

Safety Valves

Type 06440



Cryogenic Safety Valves, angle type, stainless steel, PN40

$d_0=7.0$ & 10.5 mm up to PN50

type tested TÜV-SV.1111. S/G

Standard safety valve,

with PCTFE valve seal, (D_07 = Metal to metal seated), closed bonnet

"cleaned and degreased for oxygen service"

Part No. 06440.X.0000

Inlet: male thread type G (BSPP) acc. to ISO 228/1, Outlet: female thread type G (BSPP) acc. to ISO 228/1

Part No. 06440.X.2000

Inlet: male thread type R (BSPT) acc. to ISO 7/1, Outlet: female thread type G (BSPP) acc. to ISO 228/1

Part No. 06440.X.5000

Inlet: male thread NPT acc. to ANSI B 1.20.1, Outlet: female thread type G (BSPP) acc. to ISO 228/1

Part No. 06440.X.6000

Inlet: male thread NPT acc. to ANSI B 1.20.1, Outlet: female thread NPT acc. to ANSI B 1.20.1



Applications:

Provided as safety device for protection against excessive pressure in stationary and moveable gas cylinders and pressure vessels. Approved for air gases, vapours and cryogenic liquefied gases incl. LNG.

Working temperature: -196°C / -321°F (77K) up to $+185^{\circ}\text{C}$ / $+365^{\circ}\text{F}$ (458K), with PCTFE-seal up to $+150^{\circ}\text{C}$ / 302°F (423K), suitable for horizontal installation

Materials	DIN EN	ASME/ASTM
1 Outlet body	1.4308	SA351 CF8
2 Inlet body	1.4301	SA479 Grade 304
3 Valve seal	PCTFE	
4 Disc (D_07 only)	1.4571	A479 Grade 316Ti
4 Disc	1.4541	A276 Grade 321
5 Guide plate	1.4301	SA479 Grade 304
6 Stem	1.4301	SA479 Grade 304
7 Spring	1.4571	A 313 Grade 316Ti
8 Bonnet	1.4301	A 276 Grade 304
9 Spring clamp	1.4301	SA479 Grade 304
10 Thread ring	1.4301	SA479 Grade 304
11 Cap	1.4301	SA479 Grade 304

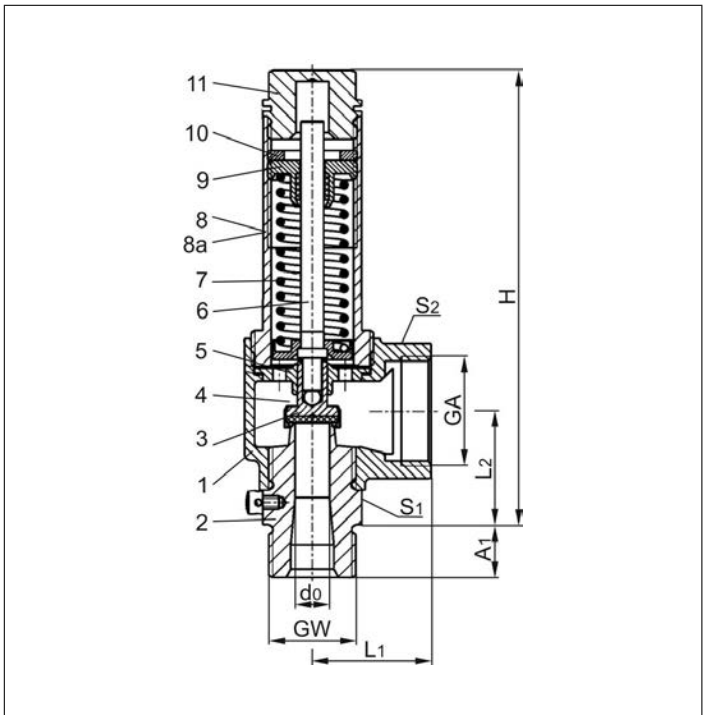

Essential: Valves are delivered at a set pressure, therefore when ordering please confirm set pressure, medium and temperature.

Standard marking acc. to Pressure Equipment Directive 97/23/EC (PED).



Type 06420	Technical data									
Nominal size	GW	1/2	3/4	1/2	3/4	3/4	1	1	1-1/4	1-1/4
Orifice	d_0	7.0	7.0	10.5	10.5	14.0	14.0	18.0	18.0	23.0
Dimension code	.X.	0704	0706	1004	1006	1406	1410	1810	1812	2312
Set pressure range	bar	0.4-50.0	0.4-50.0	0.4-50.0	0.4-50.0	0.4-40.0	0.4-40.0	0.4-40.0	0.4-40.0	0.4-10.0
Outlet	GA	1	1	1	1	1-1/4	1-1/4	1-1/2	1-1/2	1-1/2
Height	H	140	140	140	140	159	159	186	187	187
Length	A_1	14	16	14	16	16	18	18	20	20
Length	L_1	36	36	36	36	50	50	48	48	48
Length	L_2	36.5	36.5	36.5	34.5	44	44	50.5	51.5	52
Wrench size across flats	S_1	30	30	30	30	41	41	50	50	50
Wrench size across flats	S_2	41	41	41	41	50	50	58	58	58
Weight	ca. kg	0.78	0.80	0.76	0.79	1.25	1.31	1.87	1.99	1.90
Coeff. of disch. from 3.0 bar	α_w	0.78	0.78	0.69	0.69	0.66	0.66	0.66	0.66	0.54

Dimensions in mm.

Safety Valves

Type 06440



Discharge capacities

Calculation of flow rate acc. to AD2000-Merkblatt A2 / DIN EN ISO 4126-1

Medium:

Air in m³/h at 0°C and 1013.25 mbar

The capacity indicated below is for a fully opened valve.

d₀ - orifice

A₀ - flow area

Set pressure in bar (g)	GW	1/2 & 3/4	1/2 & 3/4	3/4 & 1	1 & 1-1/4	1-1/4
	d ₀ (mm)	7.0	10.5	14.0	18.0	23.0
	A ₀ (mm ²)	38.48	86.6	153.9	254.5	415.3
Medium						
Air						
0.4		24	43	77	122	157
0.5		27	49	87	141	178
1.0		40	77	130	216	287
1.5		54	101	178	290	375
2.0		65	126	219	362	472
3.0		88	175	299	494	660
4.0		110	220	375	620	829
5.0		133	266	452	748	999
6.0		156	311	529	874	1168
7.0		178	356	605	1001	1337
8.0		202	402	684	1130	1510
9.0		224	447	760	1257	1680
10.0		247	493	839	1387	1853
12.0		293	583	992	1641	-
14.0		338	674	1146	1895	-
16.0		384	764	1300	2149	-
18.0		429	855	1453	2403	-
20.0		479	954	1623	2682	-
22.0		525	1045	1778	2939	-
24.0		571	1136	1933	3195	-
26.0		617	1228	2088	3452	-
28.0		662	1319	2243	3708	-
30.0		715	1423	2421	4002	-
32.0		761	1516	2577	4261	-
34.0		807	1608	2734	4520	-
36.0		854	1700	2891	4779	-
38.0		900	1792	3047	5038	-
40.0		954	1900	3231	5342	-
42.0		1001	1993	-	-	-
44.0		1048	2086	-	-	-
46.0		1094	2179	-	-	-
48.0		1141	2272	-	-	-
50.0		1198	2385	-	-	-

Safety Valves

Type 06445



Cryogenic Safety Valves, angle type, stainless steel, PN40

$d_0=7.0$ & 10.5 mm up to PN50

type tested TÜV-SV.1111. S/G

Standard safety valve,

with PCTFE valve seal (D_07 = Metal to metal seated), closed bonnet, with lifting device

"cleaned and degreased for oxygen service"

Part No. 06445.X.0000

Inlet: male thread type G (BSPP) acc. to ISO 228/1, Outlet: female thread type G (BSPP) acc. to ISO 228/1

Part No. 06445.X.2000

Inlet: male thread type R (BSPT) acc. to 7/1, Outlet: female thread type G (BSPP) acc. to ISO 228/1

Part No. 06445.X.5000

Inlet: male thread NPT acc. to ANSI B 1.20.1, Outlet: female thread type G (BSPP) acc. to ISO 228/1

Part No. 06445.X.6000

Inlet: male thread NPT acc. to ANSI B 1.20.1, Outlet: female thread NPT acc. to ANSI B 1.20.1



Applications:

Provided as safety device for protection against excessive pressure in stationary and moveable gas cylinders and pressure vessels. Approved for air gases, vapours and cryogenic liquefied gases incl. LNG.

Working temperature: -196°C / -321°F (77K) up to $+185^{\circ}\text{C}$ / $+365^{\circ}\text{F}$ (458K), with PCTFE-seal up to $+150^{\circ}\text{C}$ / 302°F (423K), suitable for horizontal installation

Materials	DIN EN	ASME/ASTM
1 Outlet body	1.4308	SA351 CF8
2 Inlet body	1.4301	A 479 Grade 304
3 Valve seal	PCTFE	
4 Disc (D_07 only)	1.4571	A 479 Grade 316Ti
4 Disc	1.4541	A 276 Grade 321
5 Guide plate	1.4301	A 479 Grade 304
6 Stem	1.4301	A 479 Grade 304
7 Spring	1.4571	A 313 Grade 316Ti
8 Bonnet	1.4301	A 276 Grade 304
9 Spring clamp	1.4301	A 479 Grade 304
10 Thread ring	1.4301	A 479 Grade 304
11 Lifting cap	1.4301	A 479 Grade 304
12 Lifting spring	1.4571	A 313 Grade 316Ti
13 Lifting stem	1.4301	A 479 Grade 304
14 Lever	1.4408	SA351 CF8M

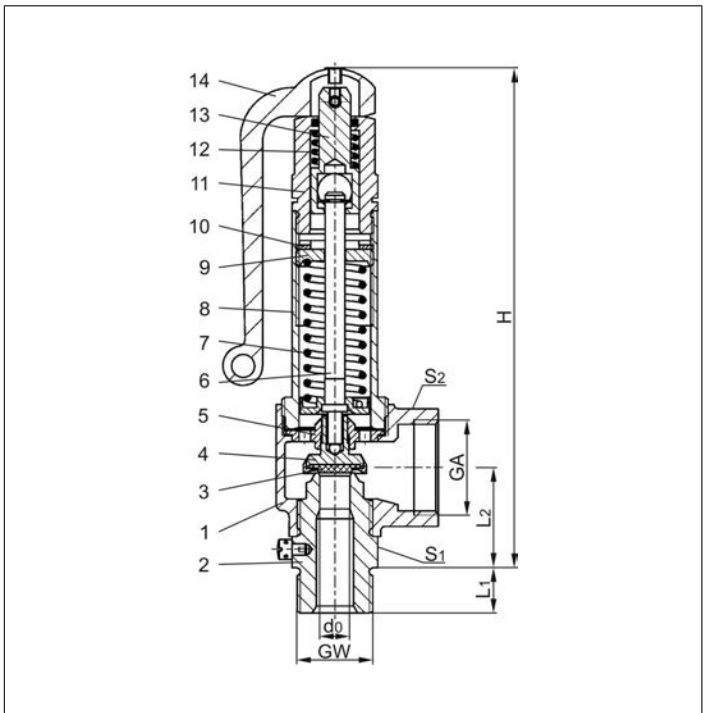

Essential: Valves are delivered at a set pressure, therefore when ordering please confirm set pressure, medium and temperature.

Standard marking acc. to Pressure Equipment Directive 97/23/EC (PED).



Type 06425	Technical data										
	Nominal size	GW	1/2	3/4	1/2	3/4	3/4	1	1	1-1/4	1-1/4
Orifice	d_0	7.0	7.0	10.5	10.5	14.0	14.0	18.0	18.0	23.0	
Dimension code	.X.	0704	0706	1004	1006	1406	1410	1810	1812	2312	
Set pressure range	bar	0.4-50.0	0.4-50.0	0.4-50.0	0.4-50.0	0.4-40.0	0.4-40.0	0.4-40.0	0.4-40.0	0.4-10.0	
Outlet	GA	1	1	1	1	1-1/4	1-1/4	1-1/2	1-1/2	1-1/2	
Height	H	176	176	176	176	196	196	239	240	239	
Length	A_1	14	16	14	16	16	18	18	20	20	
Length	L_1	36	36	36	36	50	50	48	48	48	
Length	L_2	36.5	36.5	36.5	34.5	44	44	50.5	51.5	52	
Wrench size across flats	S_1	30	30	30	30	41	41	50	50	50	
Wrench size across flats	S_2	41	41	41	41	50	50	58	58	58	
Weight	ca. kg	1.00	1.02	0.98	1.01	1.50	1.56	2.51	2.63	2.52	
Coeff. of disch. from 3.0 bar	α_w	0.78	0.78	0.69	0.69	0.66	0.66	0.66	0.66	0.54	

Dimensions in mm.

Safety Valves

Type 06445



Discharge capacities

Calculation of flow rate acc. to AD2000-Merkblatt A2 / DIN EN ISO 4126-1

Medium:

Air in m³/h at 0°C and 1013.25 mbar

The capacity indicated below is for a fully opened valve.

d₀ - orifice

A₀ - flow area

Set pressure in bar (g)	GW	1/2 & 3/4	1/2 & 3/4	3/4 & 1	1 & 1-1/4	1-1/4
	d ₀ (mm)	7.0	10.5	14.0	18.0	23.0
	A ₀ (mm ²)	38.48	86.6	153.9	254.5	415.3
Medium						
Air						
0.4		24	43	77	122	157
0.5		27	49	87	141	178
1.0		40	77	130	216	287
1.5		54	101	178	290	375
2.0		65	126	219	362	472
3.0		88	175	299	494	660
4.0		110	220	375	620	829
5.0		133	266	452	748	999
6.0		156	311	529	874	1168
7.0		178	356	605	1001	1337
8.0		202	402	679	1130	1510
9.0		224	447	684	1257	1680
10.0		247	493	760	1387	1853
12.0		293	583	992	1641	-
14.0		338	674	1146	1895	-
16.0		384	764	1300	2149	-
18.0		429	855	1453	2403	-
20.0		479	954	1623	2682	-
22.0		525	1045	1778	2939	-
24.0		571	1136	1933	3195	-
25.0		594	1182	2010	3324	-
26.0		617	1228	2088	3452	-
28.0		662	1319	2243	3708	-
30.0		715	1423	2421	4002	-
32.0		761	1516	2577	4261	-
34.0		807	1608	2734	4520	-
36.0		854	1700	2891	4779	-
38.0		900	1792	3047	5038	-
40.0		954	1900	3231	5342	-
42.0		1001	1993	-	-	-
44.0		1048	2086	-	-	-
46.0		1094	2179	-	-	-
48.0		1141	2272	-	-	-
50.0		1198	2385	-	-	-

Safety Valves

Type 06441



Cryogenic Safety Valves, angle type, stainless steel, PN40
 $d_0=7,0$ & $10,5$ mm up to PN50,
 type tested TÜV-SV.1111. S/G

Standard safety valve,
 with PCTFE valve seal (D_07 = Metal to metal seated), closed bonnet
 "cleaned and degreased for oxygen service"

Part No. 06441.X.0000

Inlet: female thread type G (BSPP) acc. to ISO 228/1
 Outlet: female thread type G (BSPP) acc. to ISO 228/1



Applications:

Provided as safety device for protection against excessive pressure in stationary and moveable gas cylinders and pressure vessels. Approved for air gases, vapours and cryogenic liquefied gases incl. LNG.
 Working temperature: -196°C / -321°F (77K) up to $+185^{\circ}\text{C}$ / $+365^{\circ}\text{F}$ (458K), with PCTFE-seal up to $+150^{\circ}\text{C}$ / 302°F (423K), suitable for horizontal installation

Materials	DIN EN	ASME/ASTM
1 Outlet body	1.4308	SA351 CF8
2 Inlet body	1.4301	A 479 Grade 304
3 Vasal seal	PCTFE	
4 Disc (D_07 only)	1.4571	A 479 Grade 316Ti
4 Disc	1.4541	A 276 Grade 321
5 Guide plate	1.4301	A 479 Grade 304
6 Stem	1.4301	A 479 Grade 304
7 Spring	1.4571	A 313 Grade 316Ti
8 Bonnet	1.4301	A 276 Grade 304
9 Spring clamp	1.4301	A 479 Grade 304
10 Thread ring	1.4301	A 479 Grade 304
11 Cap	1.4301	A 479 Grade 304

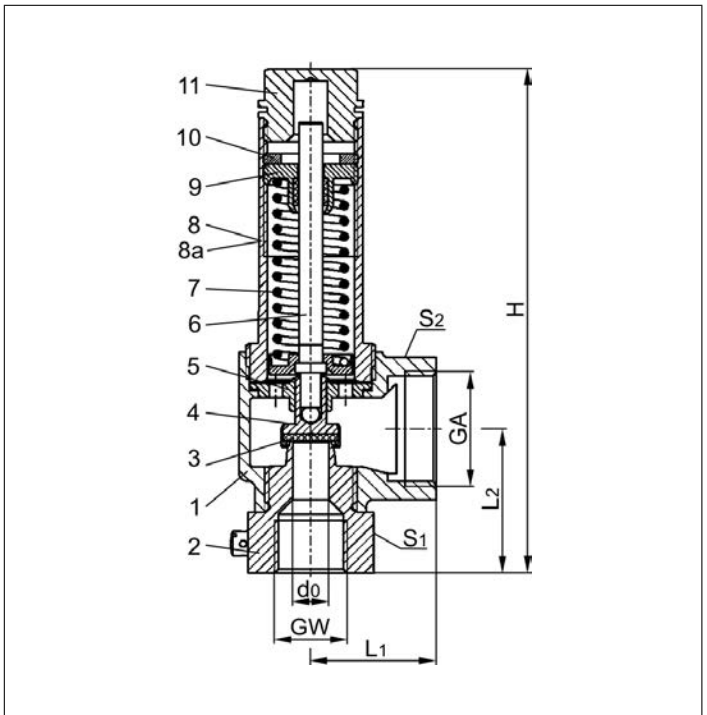

Essential: Valves are delivered at a set pressure, therefore when ordering please confirm set pressure, medium and temperature.

Standard marking acc. to Pressure Equipment Directive 97/23/EC (PED).



Type 06421	Technical data					
	GW	1/2	1/2	3/4	1	1-1/4
Nominal size	d_0	7.0	10.5	14.0	18.0	23.0
Dimension Code	.X.	0704	1004	1406	1810	2312
Set pressure range	bar	0.4-50.0	0.4-50.0	0.4-40.0	0.4-40.0	0.4-10.0
Outlet	GA	1	1	1-1/4	1-1/2	1-1/2
Height	H	145	145	164	195	200
Length	L_1	36	36	50	48	48
Length	L_2	41.5	41.5	49	59.5	65
Wrench size across flats	S_1	36	36	41	50	50
Wrench size across flats	S_2	41	41	50	58	58
Weight	ca. kg	0.80	0.795	1.25	1.87	1.79
Coeff. of discharge from 3.0 bar	α_w	0.78	0.69	0.66	0.66	0.54

Dimensions in mm.

Safety Valves

Type 06441



Discharge capacities

Calculation of flow rate acc. to AD2000-Merkblatt A2 / DIN EN ISO 4126-1

Medium:

Air in m³/h at 0°C and 1013.25 mbar

The capacity indicated below is for fully opened valve.

d₀ - orifice

A₀ - flow area

Set pressure in bar (g)	GW	1/2	1/2	3/4	1	1-1/4
	d ₀ (mm)	7.0	10.5	14.0	18.0	23.0
A ₀ (mm ²)	38.48	86.6	153.9	254.5	415.3	
Medium	Air					
0.4		24	43	77	122	157
0.5		27	49	87	141	178
1.0		40	77	130	216	287
1.5		54	101	178	290	375
2.0		65	126	219	362	472
3.0		88	175	299	494	660
4.0		110	220	375	620	829
5.0		133	266	452	748	999
6.0		156	311	529	874	1168
7.0		178	356	605	1001	1337
8.0		202	402	684	1130	1510
9.0		224	447	760	1257	1680
10.0		247	493	839	1387	1853
12.0		293	583	992	1641	-
14.0		338	674	1146	1895	-
16.0		384	764	1300	2149	-
18.0		429	855	1453	2403	-
20.0		479	954	1623	2682	-
22.0		525	1045	1778	2939	-
24.0		571	1136	1933	3195	-
25.0		594	1182	2010	3324	-
26.0		617	1228	2088	3452	-
28.0		662	1319	2243	3708	-
30.0		715	1423	2421	4002	-
32.0		761	1516	2577	4261	-
34.0		807	1608	2734	4520	-
36.0		854	1700	2891	4779	-
38.0		900	1792	3047	5038	-
40.0		954	1900	3231	5342	-
42.0		1001	1993	-	-	-
44.0		1048	2086	-	-	-
46.0		1094	2179	-	-	-
48.0		1141	2272	-	-	-
50.0		1198	2385	-	-	-

Safety Valves

Type 06446



Cryogenic Safety Valves, angle type, stainless steel, PN40
 $d_0=7,0$ & $10,5$ mm up to PN50,
 type tested TÜV-SV.1111. S/G

Standard safety valve,
 with PCTFE valve seal (D_07 = Metal to metal seated), closed bonnet, with lifting device
 "cleaned and degreased for oxygen service"

Part No. 06446.X.0000

Inlet: female thread type G (BSPP) acc. to ISO 228/1
 Outlet: female thread type G (BSPP) acc. to ISO 228/1



Applications:

Provided as safety device for protection against excessive pressure in stationary and moveable gas cylinders and pressure vessels. Approved for air gases, vapours and cryogenic liquefied gases incl. LNG.
 Working temperature: -196°C / -321°F (77K) up to $+185^{\circ}\text{C}$ / $+365^{\circ}\text{F}$ (458K), with PCTFE-seal up to $+150^{\circ}\text{C}$ / 302°F (423K), suitable for horizontal installation

Materials	DIN EN	ASME/ASTM
1 Outlet body	1.4308	SA351 CF8
2 Inlet body	1.4301	A 479 Grade 304
3 Valve seal	PCTFE	
4 Disc (D_07 only)	1.4571	A 479 Grade 316Ti
4 Disc	1.4541	A 276 Grade 321
5 Guide plate	1.4301	A 479 Grade 304
6 Stem	1.4301	A 479 Grade 304
7 Spring	1.4571	A 313 Grade 316Ti
8 Bonnet	1.4301	A 276 Grade 304
9 Spring clamp	1.4301	A 479 Grade 304
10 Thread ring	1.4301	A 479 Grade 304
11 Lifting cap	1.4301	A 479 Grade 304
12 Lifting spring	1.4571	A 313 Grade 316Ti
13 Lifting stem	1.4301	A 479 Grade 304
14 Lever	1.4408	SA351 CF8M

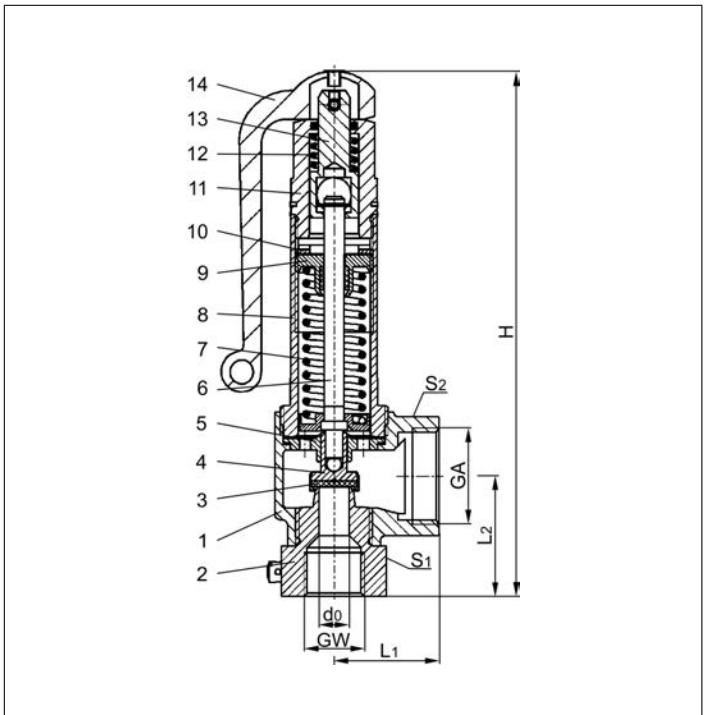

Essential: Valves are delivered at a set pressure, therefore when ordering please confirm set pressure, medium and temperature.

Standard marking acc. to Pressure Equipment Directive 97/23/EC (PED).



Type 06426	Technical Data					
Nominal size	GW	1/2	1/2	3/4	1	1-1/4
Orifice	d_0	7.0	10.5	14.0	18.0	23.0
Dimension code	.X.	0704	1004	1406	1810	2312
Set pressure range	bar	0.4-50.0	0.4-50.0	0.4-40.0	0.4-40.0	0.4-10.0
Outlet	GA	1	1	1-1/4	1-1/2	1-1/2
Height	H	181	181	201	247	252
Length	L_1	36	36	50	48	48
Length	L_2	41.5	41.5	49	59.5	65
Wrench size across flats	S_1	36	36	41	50	50
Wrench size across flats	S_2	41	41	50	58	58
Weight	ca. kg	1.02	1.01	1.50	2.45	2.40
Coeff. of discharge from 3.0 bar	α_w	0.78	0.69	0.66	0.66	0.54

Dimensions in mm.

Safety Valves

Type 06446



Discharge capacities

Calculation of flow rate acc. to AD2000-Merkblatt A2 / DIN EN ISO 4126-1

Medium:

Air in m³/h at 0°C and 1013.25 mbar

The capacity indicated below is for fully opened valve.

d₀ - orifice

A₀ - flow area

Set pressure in bar (g)	GW	1/2	1/2	3/4	1	1-1/4
	d ₀ (mm)	7.0	10.5	14.0	18.0	23.0
A ₀ (mm ²)	38.48	86.6	153.9	254.5	415.3	
Medium	Air					
0.4		24	43	77	122	157
0.5		27	49	87	141	178
1.0		40	77	130	216	287
1.5		54	101	178	290	375
2.0		65	126	219	362	472
3.0		88	175	299	494	660
4.0		110	220	375	620	829
5.0		133	266	452	748	999
6.0		156	311	529	874	1168
7.0		178	356	605	1001	1337
8.0		202	402	684	1130	1510
9.0		224	447	760	1257	1680
10.0		247	493	839	1387	1853
12.0		293	583	992	1641	-
14.0		338	674	1146	1895	-
16.0		384	764	1300	2149	-
18.0		429	855	1453	2403	-
20.0		479	954	1623	2682	-
22.0		525	1045	1778	2939	-
24.0		571	1136	1933	3195	-
25.0		594	1182	2010	3324	-
26.0		617	1228	2088	3452	-
28.0		662	1319	2243	3708	-
30.0		715	1423	2421	4002	-
32.0		761	1516	2577	4261	-
34.0		807	1608	2734	4520	-
36.0		854	1700	2891	4779	-
38.0		900	1792	3047	5038	-
40.0		954	1900	3231	5342	-
42.0		1001	1993	-	-	-
44.0		1048	2086	-	-	-
46.0		1094	2179	-	-	-
48.0		1141	2272	-	-	-
50.0		1198	2385	-	-	-

Safety Valves

Type 06801 with bellow seal



Stainless steel bellow sealed Safety Valves, angle type, PN40, type tested TÜV-SV.1105. S/G/L orifice $d_0 = 12.5$ mm TÜV-SV.1105. only S/G

Standard safety valve,
metal to metal seated, closed bonnet
"cleaned and degreased for oxygen service"

Part No. 06801.X.0000

Inlet: male thread type G (BSPP) acc. to ISO 228/1, Outlet: female thread type G (BSPP) acc. to ISO 228/1

Part No. 06801.X.2000

Inlet: male thread type R (BSPT) acc. to ISO 7/1, Outlet: female thread type G (BSPP) acc. to ISO 228/1

Part No. 06801.X.5000

Inlet: male thread NPT acc. to ANSI B 1.20.1, Outlet: female thread type G (BSPP) acc. to ISO 228/1

Part No. 06801.X.6000

Inlet: male thread NPT acc. to ANSI B 1.20.1, Outlet: female thread NPT acc. to ANSI B 1.20.1



Applications:

Provided as safety device for protection against excessive pressure in stationary and moveable gas cylinders and pressure vessels. Approved for non-inflammable and inflammable vapours, gases and fluids.

Working temperature: -270°C / -454°F (3K) up to $+225^{\circ}\text{C}$ / $+437^{\circ}\text{F}$ (498K)

Maximum allowed back pressure: 15% of set pressure, pressure-temperature must be observed

Materials	DIN EN	ASME/ASTM
1 Inlet body	1.4571	A 276 Grade 316Ti
2 Outlet body	1.4308	A 351 CF8
3 Disc	1.4541	A 276 Grade 321
4 Bellow	1.4571	A 276 Grade 316Ti
5 Bellow stem	1.4571	A 276 Grade 316Ti
6 Stem	CW453K	B 103 UNS C52100
7 Bonnet	1.4301	A 276 Grade 304
8 Spring	1.4571	A 276 Grade 316Ti
9 Cap	1.4301	A 276 Grade 304

Important:

For nominal size GW 3/4, $d_0 = 15.0$ mm the back pressure reduces the blow off performance of the safety valve (see diagram 06801-3/4).

Essential: Valves are delivered at a set pressure, therefore when ordering please confirm set pressure, medium and temperature.

Standard marking acc. to Pressure Equipment Directive 97/23/EC (PED).

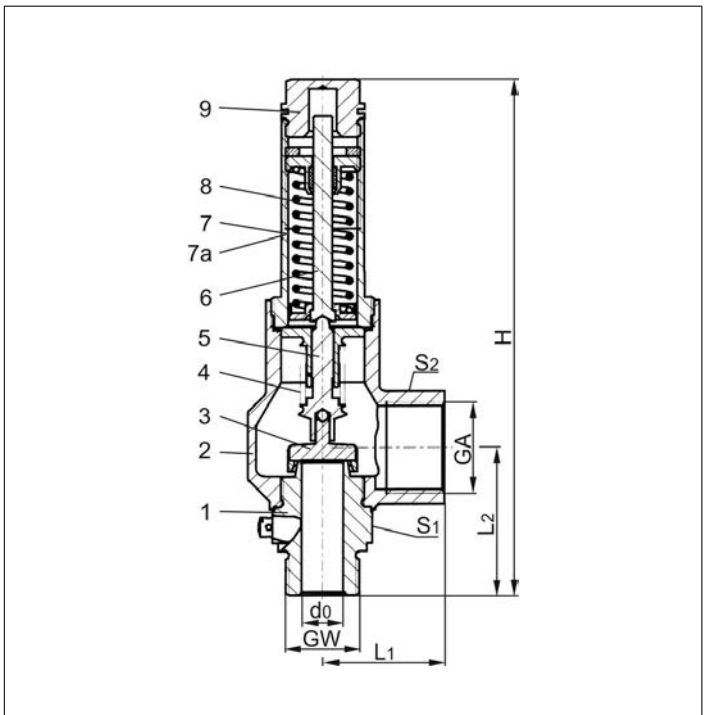

Type 06801	Technical data				
Nominal size	GW	1/2	3/4	1	1
Orifice	d_0	12.5	15	20	23
Dimension code	.X.	1204	1506	2010	2310
Set pressure range	bar	3.0-25.0	3.0-25.0	3.0-25.0	3.0-25.0
Outlet	GA	G 1	G 1	G 1-1/4	G 1-1/2
Height	H	186	190	205	255
Length	L_1	44	44	51	56
Length	L_2	52	54	63	65
Wrench size across flats	S_1	36	36	41	50
Wrench size across flats	S_2	41	41	50	55
Weight	ca. kg	1.03	1.05	1.70	2.45
Coeff. of discharge vapours, gases	α_w	0.60	0.50	0.60	0.66
Coeff. of discharge fluids	α_w	-	0.39	0.45	0.48

Dimensions in mm.

Safety Valves

Type 06801 with bellow seal



Discharge capacities

Calculation of flow rate acc. to AD2000-Merkblatt A2 / DIN EN ISO 4126-1

Medium:

Air in m³/h at 0°C and 1013.25 mbar

Water in kg/h

Saturated steam in kg/h

The capacity indicated below is for a fully opened valve.

Maximum allowed back pressure: 15% of set pressure.

For nominal size GW 3/4 the back pressure reduces the blow off performance of the safety valve (see diagram 06801-3/4).

d₀ - orifice

A₀ - flow area

Set pressure in bar (g)	GW	1/2	3/4	1	1	1/2	3/4	1	1	3/4	1	1
	d ₀ (mm)	12.5	15.0	20.0	23.0	12.5	15.0	20.0	23.0	15.0	20.0	23.0
	A ₀ (mm ²)	122.7	176.7	314.2	415.5	122.7	176.7	314.2	415.5	176.7	314.2	415.5
Medium	Air						Saturated steam				Water	
3.0		216	260	555	807	169	203	433	630	6374	13075	18445
4.0		272	326	696	1013	211	253	540	786	7360	15098	21298
5.0		328	393	839	1221	252	303	647	942	8229	16880	23812
6.0		383	460	981	1428	294	353	753	1096	9014	18491	26085
7.0		438	526	1123	1634	335	402	859	1249	9736	19973	28175
8.0		495	594	1269	1846	376	452	964	1403	10409	21352	30120
9.0		551	661	1411	2053	417	501	1069	1555	11040	22647	31947
10.0		608	729	1556	2265	458	550	1174	1708	11637	23872	33676
12.0		719	863	1842	2679	540	648	1384	2013	12748	26150	36890
14.0		830	997	2127	3094	622	746	1592	2317	13770	28246	39846
16.0		942	1130	2412	3509	703	844	1802	2621	14720	30196	42597
18.0		1053	1264	2697	3924	785	942	2010	2924	15613	32028	45181
20.0		1176	1411	3011	4380	866	1040	2219	3228	16458	33760	47625
22.0		1288	1546	3298	4799	948	1137	2427	3531	17261	35408	49949
25.0		1457	1748	3730	5427	1070	1284	2739	3985	18401	37745	53246

Diagram 06801-3/4

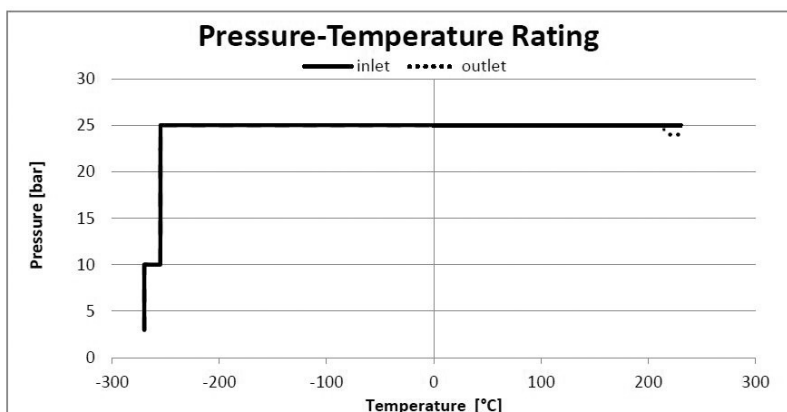
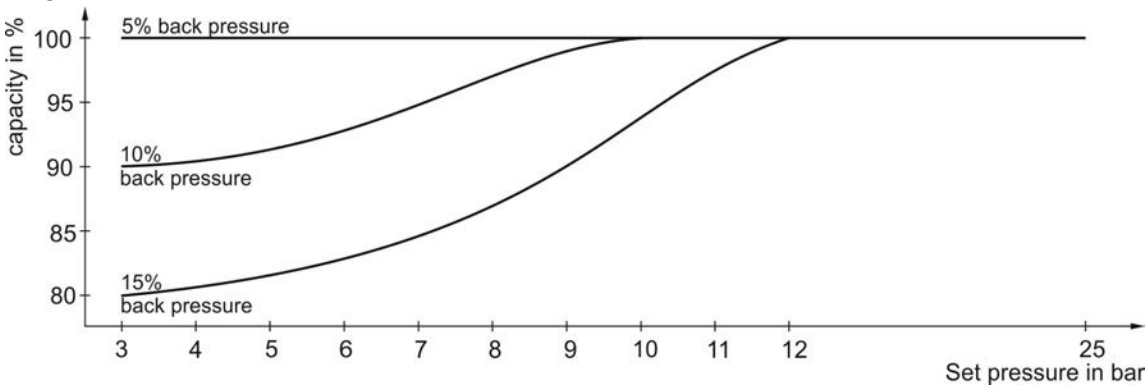

Safety Valves

Type 06806 with bellow seal



Stainless steel bellow sealed Safety Valves, angle type, PN40, type tested TÜV-SV.1105. S/G/L orifice $d_0 = 12.5$ mm TÜV-SV.1105. only S/G

Standard safety valve,
metal to metal seated, closed bonnet, with lifting device
"cleaned and degreased for oxygen service"

Part No. 06806.X.0000

Inlet: male thread type G (BSPP) acc. to ISO 228/1, Outlet: female thread type G (BSPP) acc. to ISO 228/1

Part No. 06806.X.2000

Inlet: male thread type R (BSPT) acc. to ISO 7/1, Outlet: female thread type G (BSPP) acc. to ISO 228/1

Part No. 06806.X.5000

Inlet: male thread NPT acc. to ANSI B 1.20.1, Outlet: female thread type G (BSPP) acc. to ISO 228/1

Part No. 06806.X.6000

Inlet: male thread NPT acc. to ANSI B 1.20.1, Outlet: female thread NPT acc. to ANSI B 1.20.1



Applications:

Provided as safety device for protection against excessive pressure in stationary and moveable gas cylinders and pressure vessels. Approved for non-inflammable and inflammable vapours, gases and fluids.

Working temperature: $-270^{\circ}\text{C} / -454^{\circ}\text{F}$ (3K) up to $+225^{\circ}\text{C} / +437^{\circ}\text{F}$ (498K)

Maximum allowed back pressure: 15% of set pressure, pressure-temperature must be observed

Materials	DIN EN	ASME/ASTM
1 Inlet body	1.4571	A 276 Grade 316Ti
2 Outlet body	1.4308	A 351 CF8
3 Disc	1.4541	A 276 Grade 321
4 Bellow	1.4571	A 276 Grade 316Ti
5 Bellow stem	1.4571	A 276 Grade 316Ti
6 Stem	CW453K	B 103 UNS C52100
7 Bonnet	1.4301	A 276 Grade 304
8 Spring	1.4571	A 276 Grade 316Ti
9 Lifting cap	1.4301	A 276 Grade 304
10 Lever	1.4408	A 351 CF8M

Important:

For nominal size GW 3/4, $d_0 = 15.0$ mm the back pressure reduces the blow off performance of the safety valve (see diagram 06806-3/4).

Essential: Valves are delivered at a set pressure, therefore when ordering please confirm set pressure, medium and temperature.

Standard marking acc. to Pressure Equipment Directive 97/23/EC (PED).

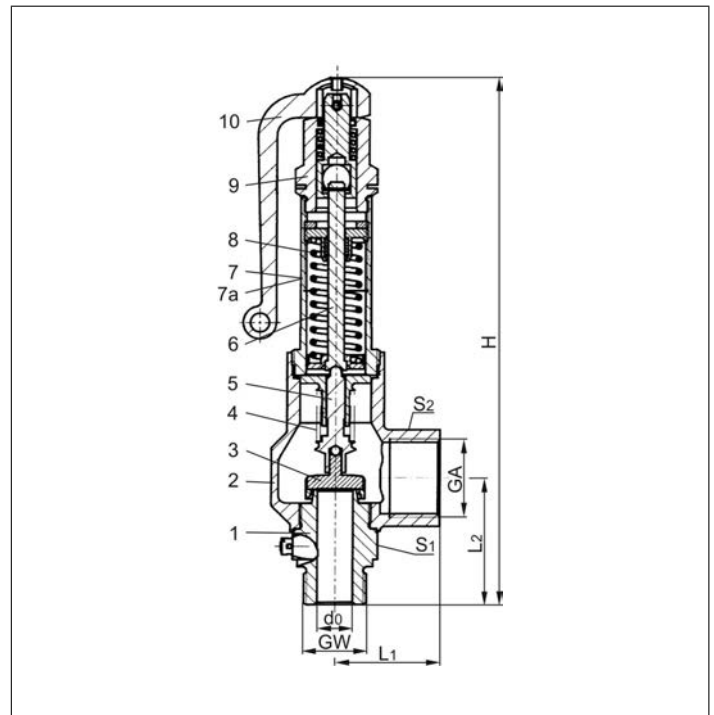

Type 06806	Technical data					
	Nominal size	GW	1/2	3/4	1	1
Orifice	d_0	12.5	15	20	23	23
Dimension code	.X.	1204	1506	2010	2310	2310
Set pressure range	bar	3.0-25.0	3.0-25.0	3.0-25.0	3.0-25.0	3.0-25.0
Outlet	GA	G 1	G 1	G 1-1/4	G 1-1/2	G 1-1/2
Height	H	221	225	250	305	305
Length	L_1	44	44	51	56	56
Length	L_2	52	54	63	65	65
Wrench size across flats	S_1	36	36	41	50	50
Wrench size across flats	S_2	41	41	50	55	55
Weight	ca. kg	1.23	1.25	1.95	3.10	3.10
Coeff. of discharge vapours, gases	α_w	0.60	0.50	0.60	0.66	0.66
Coeff. of discharge fluids	α_w	-	0.39	0.45	0.48	0.48

Dimensions in mm.

Safety Valves

Type 06806 with bellow seal



Discharge capacities

Calculation of flow rate acc. to AD2000-Merkblatt A2 / DIN EN ISO 4126-1

Medium:

Air in m³/h at 0°C and 1013.25 mbar

Water in kg/h

Saturated steam in kg/h

The capacity indicated below is for a fully opened valve.

Maximum allowed back pressure: 15% of set pressure.

For nominal size GW 3/4 the back pressure reduces the blow off performance of the safety valve (see diagram 06806-3/4).

d₀ - orifice

A₀ - flow area

Set pressure in bar (g)	GW	1/2	3/4	1	1	1/2	3/4	1	1	3/4	1	1	
	d ₀ (mm)	12.5	15.0	20.0	23.0	12.5	15.0	20.0	23.0	15.0	20.0	23.0	
A ₀ (mm ²)	122.7	176.7	314.2	415.5	122.7	176.7	314.2	415.5	122.7	176.7	314.2	415.5	
Medium		Air				Saturated steam				Water			
3.0		216	260	555	807	169	203	433	630	6374	13075	18445	
4.0		272	326	696	1013	211	253	540	786	7360	15098	21298	
5.0		328	393	839	1221	252	303	647	942	8229	16880	23812	
6.0		383	460	981	1428	294	353	753	1096	9014	18491	26085	
7.0		438	526	1123	1634	335	402	859	1249	9736	19973	28175	
8.0		495	594	1269	1846	376	452	964	1403	10409	21352	30120	
9.0		551	661	1411	2053	417	501	1069	1555	11040	22647	31947	
10.0		608	729	1556	2265	458	550	1174	1708	11637	23872	33676	
12.0		719	863	1842	2679	540	648	1384	2013	12748	26150	36890	
14.0		830	997	2127	3094	622	746	1592	2317	13770	28246	39846	
16.0		942	1130	2412	3509	703	844	1802	2621	14720	30196	42597	
18.0		1053	1264	2697	3924	785	942	2010	2924	15613	32028	45181	
20.0		1176	1411	3011	4380	866	1040	2219	3228	16458	33760	47625	
22.0		1288	1546	3298	4799	948	1137	2427	3531	17261	35408	49949	
25.0		1457	1748	3730	5427	1070	1284	2739	3985	18401	37745	53246	

Diagram 06806-3/4

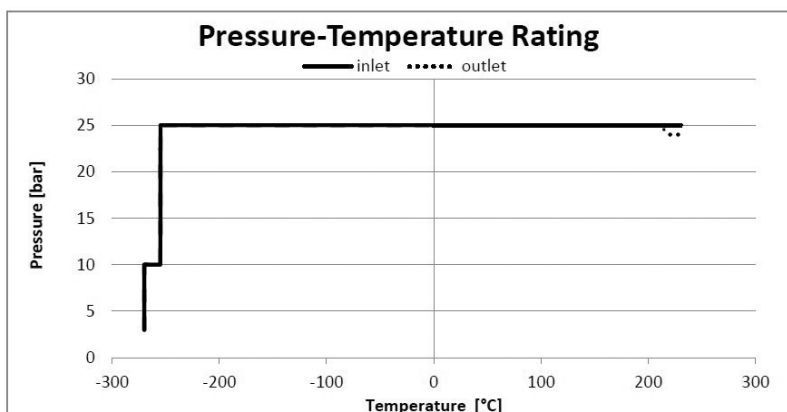
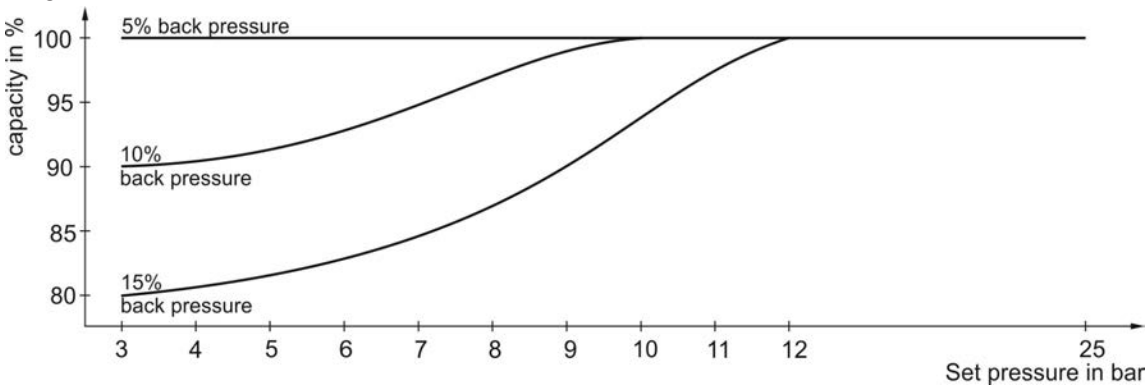

Safety Valves

Type 06800 with bellow seal



Stainless steel bellow sealed Safety Valves, angle type, PN40, type tested TÜV-SV.1105. S/G/L orifice $d_0 = 12.5$ mm TÜV-SV.1105. only S/G

Standard safety valve,
metal to metal seated, closed bonnet
"cleaned and degreased for oxygen service"

Part No. 06800.X.0000

Inlet: female thread type G (BSPP) acc. to ISO 228/1,
Outlet: female thread type G (BSPP) acc. to ISO 228/1

Part No. 06800.X.5000

Inlet: female NPT acc. to ANSI B 1.20.1,
Outlet: female thread type G (BSPP) acc. to ISO 228/1

Part No. 06800.X.6000

Inlet: female thread NPT acc. to ANSI B 1.20.1,
Outlet: female thread NPT acc. to ANSI B 1.20.1

Applications:

Provided as safety device for protection against excessive pressure in stationary and moveable gas cylinders and pressure vessels. Approved for non-inflammable and inflammable vapours, gases and fluids.
Working temperature: $-270^{\circ}\text{C} / -454^{\circ}\text{F}$ (3K) up to $+225^{\circ}\text{C} / +437^{\circ}\text{F}$ (498K)
Maximum allowed back pressure: 15% of set pressure, pressure-temperature must be observed



Materials	DIN EN	ASME/ASTM
1 Inlet body	1.4571	A 276 Grade 316Ti
2 Outlet body	1.4308	A 351 CF8
3 Disc	1.4541	A 276 Grade 321
4 Bellow	1.4571	A 276 Grade 316Ti
5 Bellow stem	1.4571	A 276 Grade 316Ti
6 Stem	CW453K	B 103 UNS C52100
7 Bonnet	1.4301	A 276 Grade 304
8 Spring	1.4571	A 276 Grade 316Ti
9 Cap	1.4301	A 276 Grade 304

Important:

For nominal size GW 1/2, $d_0 = 15.0$ mm the back pressure reduces the blow off performance of the safety valve (see diagram 06800-1/2, $d_0 = 15.0$).

Essential: Valves are delivered at a set pressure, therefore when ordering please confirm set pressure, medium and temperature.

Standard marking acc. to Pressure Equipment Directive 97/23/EC (PED).

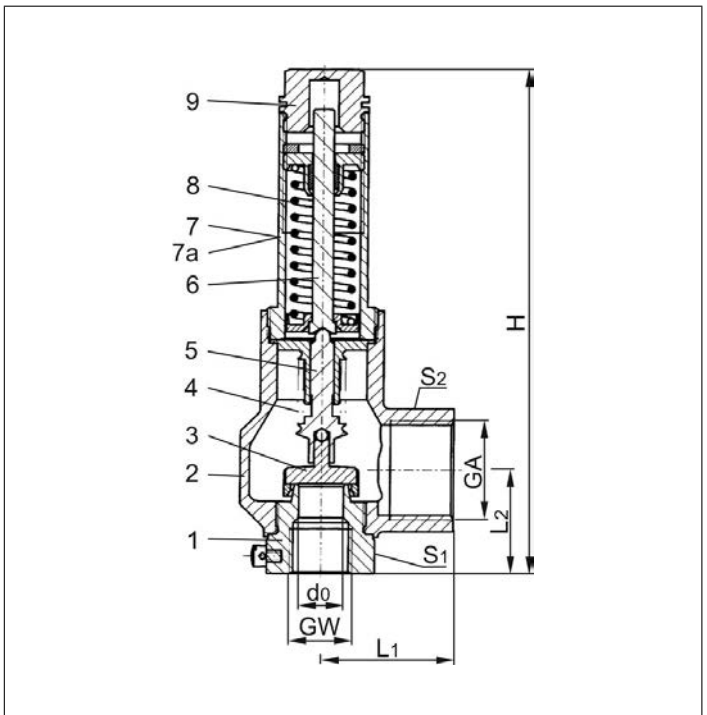

Type 06800	Technical data				
Nominal size	GW	1/2	1/2	3/4	1
Orifice	d_0	12.5	15	20	23
Dimension code	.X.	1204	1504	2006	2310
Set pressure range	bar	3.0-25.0	3.0-25.0	3.0-25.0	3.0-25.0
Outlet	GA	G 1	G 1	G 1-1/4	G 1-1/2
Height	H	170	170	198	245
Length	L_1	44	44	51	56
Length	L_2	35	35	48	58
Wrench size across flats	S_1	36	36	41	50
Wrench size across flats	S_2	41	41	50	55
Weight	ca. kg	1.0	0.97	1.65	2.50
Coeff. of discharge vapours, gases	α_w	0.60	0.50	0.60	0.66
Coeff. of discharge fluids	α_w	-	0.39	0.45	0.48

Dimensions in mm.

Safety Valves

Type 06800 with bellow seal



Discharge capacities

Calculation of flow rate acc. to AD2000-Merkblatt A2 / DIN EN ISO 4126-1

Medium:

Air in m³/h at 0°C and 1013.25 mbar

Water in kg/h

Saturated steam in kg/h

The capacity indicated below is for a fully opened valve.

Maximum allowed back pressure: 15% of set pressure.

For nominal size GW 1/2, d₀ = 15.0 mm the back pressure reduces the blow off performance of the safety valve (see diagram 06800-1/2, d₀ = 15.0)

d₀ - orifice

A₀ - flow area

Set pressure in bar (g)	GW	1/2	1/2	3/4	1	1/2	1/2	3/4	1	1/2	3/4	1
	d ₀ (mm)	12.5	15.0	20.0	23.0	12.5	15.0	20.0	23.0	15.0	20.0	23.0
	A ₀ (mm ²)	122.7	176.7	314.2	415.5	122.7	176.7	314.2	415.5	176.7	314.2	415.5
Medium	Air				Saturated steam				Water			
3.0		216	260	555	807	169	203	433	630	6374	13075	18445
4.0		272	326	696	1013	211	253	540	786	7360	15098	21298
5.0		328	393	839	1221	252	303	647	942	8229	16880	23812
6.0		383	460	981	1428	294	353	753	1096	9014	18491	26085
7.0		438	526	1123	1634	335	402	859	1249	9736	19973	28175
8.0		495	594	1269	1846	376	452	964	1403	10409	21352	30120
9.0		551	661	1411	2053	417	501	1069	1555	11040	22647	31947
10.0		608	729	1556	2265	458	550	1174	1708	11637	23872	33676
12.0		719	863	1842	2679	540	648	1384	2013	12748	26150	36890
14.0		830	997	2127	3094	622	746	1592	2317	13770	28246	39846
16.0		942	1130	2412	3509	703	844	1802	2621	14720	30196	42597
18.0		1053	1264	2697	3924	785	942	2010	2924	15613	32028	45181
20.0		1176	1411	3011	4380	866	1040	2219	3228	16458	33760	47625
22.0		1288	1546	3298	4799	948	1137	2427	3531	17261	35408	49949
25.0		1457	1748	3730	5427	1070	1284	2739	3985	18401	37745	53246

Diagram 06800-1/2, d₀=15,0

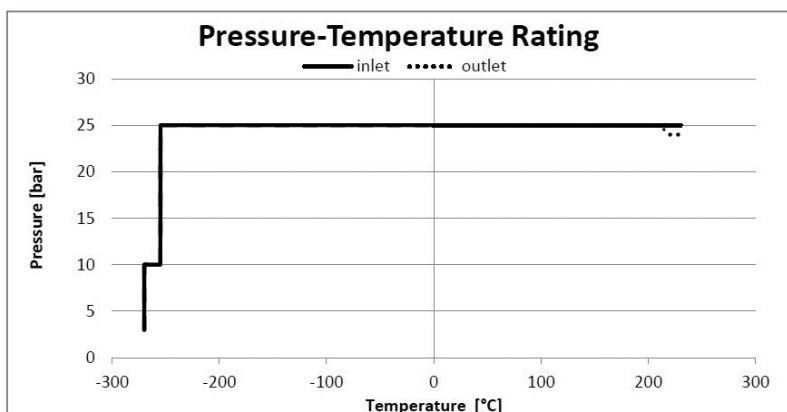
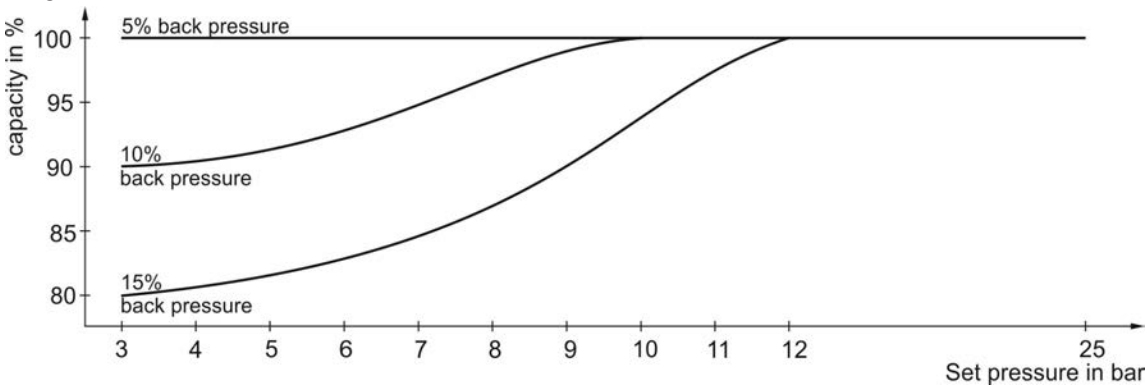

Safety Valves

Type 06805 with bellow seal



Stainless steel bellow sealed Safety Valves, angle type, PN40, type tested TÜV-SV.1105. S/G/L orifice $d_0 = 12.5$ mm TÜV-SV.1105. only S/G

Standard safety valve,
metal to metal seated, closed bonnet, with lifting device
"cleaned and degreased for oxygen service"

Part No. 06805.X.0000

Inlet: female thread type G (BSPP) acc. to ISO 228/1,
Outlet: female thread type G (BSPP) acc. to ISO 228/1

Part No. 06805.X.5000

Inlet: female thread NPT acc. to ANSI B 1.20.1,
Outlet: female thread type G (BSPP) acc. to ISO 228/1

Part No. 06805.X.6000

Inlet: female thread NPT acc. to ANSI B 1.20.1,
Outlet: female thread NPT acc. to ANSI B 1.20.1

Applications:

Provided as safety device for protection against excessive pressure in stationary and moveable gas cylinders and pressure vessels. Approved for non-inflammable and inflammable vapours, gases and fluids.

Working temperature: $-270^{\circ}\text{C} / -454^{\circ}\text{F}$ (3K) up to $+225^{\circ}\text{C} / +437^{\circ}\text{F}$ (498K)

Maximum allowed back pressure: 15% of set pressure, pressure-temperature must be observed



Materials	DIN EN	ASME/ASTM
1 Inlet body	1.4571	A 276 Grade 316Ti
2 Outlet body	1.4308	A 351 CF8
3 Disc	1.4541	A 276 Grade 321
4 Bellow	1.4571	A 276 Grade 316Ti
5 Bellow stem	1.4571	A 276 Grade 316Ti
6 Stem	CW453K	B 103 UNS C52100
7 Bonnet	1.4301	A 276 Grade 304
8 Spring	1.4571	A 276 Grade 316Ti
9 Lifting cap	1.4301	A 276 Grade 304
10 Lever	1.4408	A 351 CF8M

Important:

For nominal size GW 1/2, $d_0 = 15.0$ mm the back pressure reduces the blow off performance of the safety valve (see diagram 06805-1/2, $d_0 = 15.0$).

Essential: Valves are delivered at a set pressure, therefore when ordering please confirm set pressure, medium and temperature.

Standard marking acc. to Pressure Equipment Directive 97/23/EC (PED).

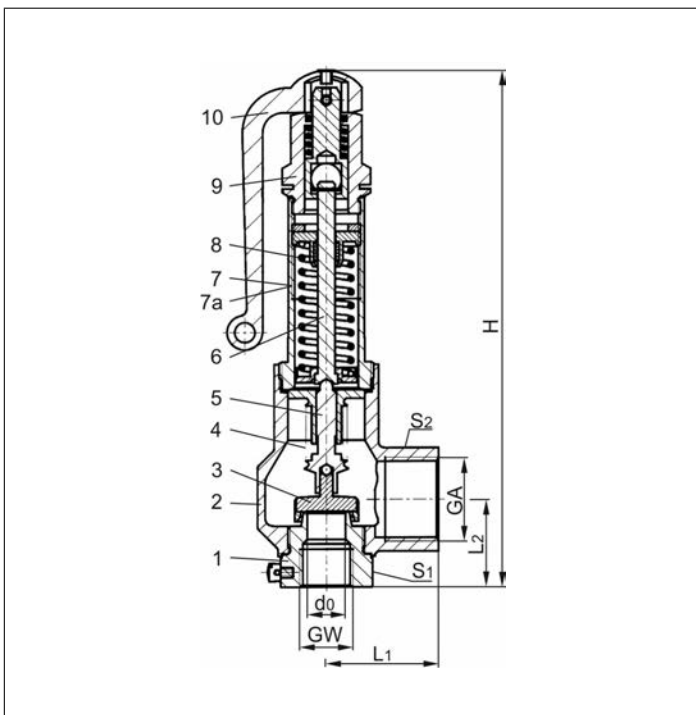

Type 6805	Technical data					
Nominal size	GW	1/2	1/2	3/4	3/4	1
Orifice	d_0	12.5	15	15	20	23
Dimension code	.X.	1204	1504	1506	2006	2310
Set pressure range	bar	3.0-25.0	3.0-25.0	3.0-25.0	3.0-25.0	3.0-25.0
Outlet	GA	G 1	G 1	G 1	G 1-1/4	G 1-1/2
Height	H	205	210	215	243	295
Length	L_1	44	44	44	51	56
Length	L_2	35	35	40	48	58
Wrench size across flats	S_1	36	36	41	41	50
Wrench size across flats	S_2	41	41	41	50	55
Weight	ca. kg	1.24	1.21	1.31	1.88	3.15
Coeff. of discharge vapours, gases	α_w	0.60	0.50	0.50	0.60	0.66
Coeff. of discharge fluids	α_w	-	0.39	0.39	0.45	0.48

Dimensions in mm.

Safety Valves

Type 06805 with bellow seal



Discharge capacities

Calculation of flow rate acc. to AD2000-Merkblatt A2 / DIN EN ISO 4126-1

Medium:

Air in m³/h at 0°C and 1013.25 mbar

Water in kg/h

Saturated steam in kg/h

The capacity indicated below is for a fully opened valve.

Maximum allowed back pressure: 15% of set pressure.

For nominal size GW 1/2, d₀ = 15.0 mm the back pressure reduces the blow off performance of the safety valve (see diagram 06805-1/2, d₀ = 15.0).

d₀ - orifice

A₀ - flow area

Set pressure in bar (g)	GW	1/2	1/2 & 3/4	3/4	1	1/2	1/2 & 3/4	3/4	1	1/2 & 3/4	3/4	1
	d ₀ (mm)	12.5	15.0	20.0	23.0	12.5	15.0	20.0	23.0	15.0	20.0	23.0
	A ₀ (mm ²)	122.7	176.7	314.2	415.5	122.7	176.7	314.2	415.5	176.7	314.2	415.5
Medium	Air				Saturated steam				Water			
3.0		216	260	555	807	169	203	433	630	6374	13075	18445
4.0		272	326	696	1013	211	253	540	786	7360	15098	21298
5.0		328	393	839	1221	252	303	647	942	8229	16880	23812
6.0		383	460	981	1428	294	353	753	1096	9014	18491	26085
7.0		438	526	1123	1634	335	402	859	1249	9736	19973	28175
8.0		495	594	1269	1846	376	452	964	1403	10409	21352	30120
9.0		551	661	1411	2053	417	501	1069	1555	11040	22647	31947
10.0		608	729	1556	2265	458	550	1174	1708	11637	23872	33676
12.0		719	863	1842	2679	540	648	1384	2013	12748	26150	36890
14.0		830	997	2127	3094	622	746	1592	2317	13770	28246	39846
16.0		942	1130	2412	3509	703	844	1802	2621	14720	30196	42597
18.0		1053	1264	2697	3924	785	942	2010	2924	15613	32028	45181
20.0		1176	1411	3011	4380	866	1040	2219	3228	16458	33760	47625
22.0		1288	1546	3298	4799	948	1137	2427	3531	17261	35408	49949
25.0		1457	1748	3730	5427	1070	1284	2739	3985	18401	37745	53246

Diagram 06805-1/2, d₀=15,0

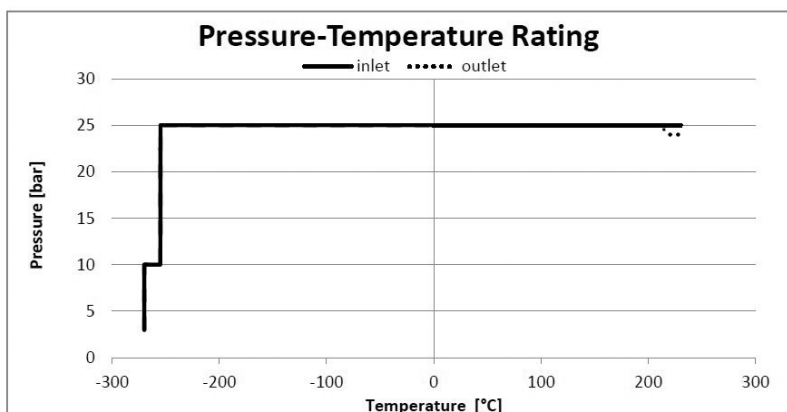
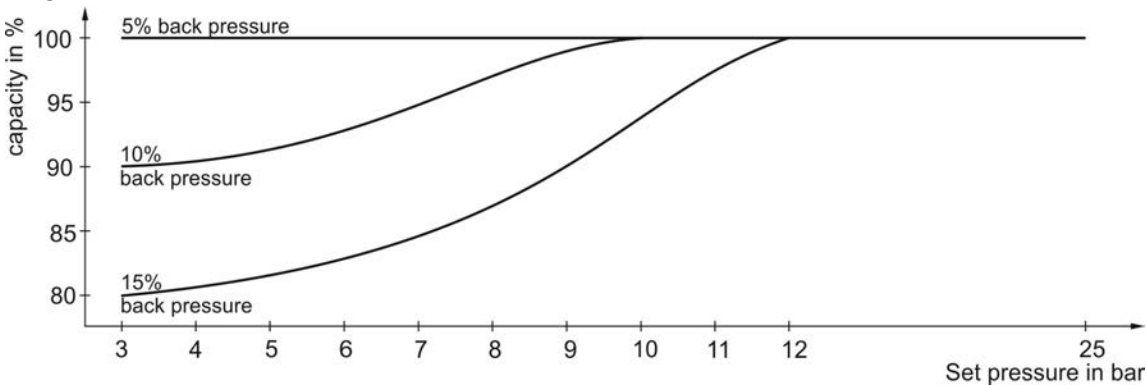

Safety Valves

Type 06810, Type 06815



Safety Valves, angle type, stainless steel, type tested, TÜV-SV.1130. D/G/F

Standard safety valve
 metal to metal seated, "cleaned and degreased for oxygen service"
 closed bonnet, gastight cap or lifting device
 Inlet: male thread type G (BSPP) acc. to ISO 228/1
 Outlet: female thread type G (BSPP) acc. to ISO 228/1

Part No. 06810.X.000000M (Pmax 16.0 bar)

Part No. 06810.X.000000H (Pmax 180.0 bar) stellited version
 with gastight cap

Part No. 06815.X.000000M (Pmax 16.0 bar)

Part No. 06815.X.000000H (Pmax 180.0 bar) stellited version
 with lifting device

Available options - on request only:

· Flange-, NPT- or Tri-Clamp connection for in- and outlet



Applications:

Provided as safety device for protection against excessive pressure in gas cylinders and pressure vessels. Approved for gases, vapours and liquids. Working temperature: -270°C / -454°F (3K) up to +400°C / +752°F (673K)

Pressure-temperature must be observed, suitable for horizontal installation from 20 bar

Materials	DIN EN	ASME/ASTM
1 Outlet body	1.4408	A 351 CF 8M
2 Inlet body	1.4571	A 276 Grade 316Ti
3 Disc	1.4571	A 276 Grade 316Ti
4 Stem	1.4404	A 276 Grade 316L
5 Bonnet	1.4408	A 351 CF8M
6 Spring	1.4571	A 313 Grade 316Ti
7 Cap	1.4408	A 351 CF8M
8 Lifting cap	1.4408	A 351 CF8M
9 Lever	1.4301	A 276 Grade 304

Essential: Valves are delivered at a set pressure, therefore when ordering please confirm set pressure, medium and temperature.

Standard marking acc. to Pressure Equipment Directive 97/23/EC (PED).

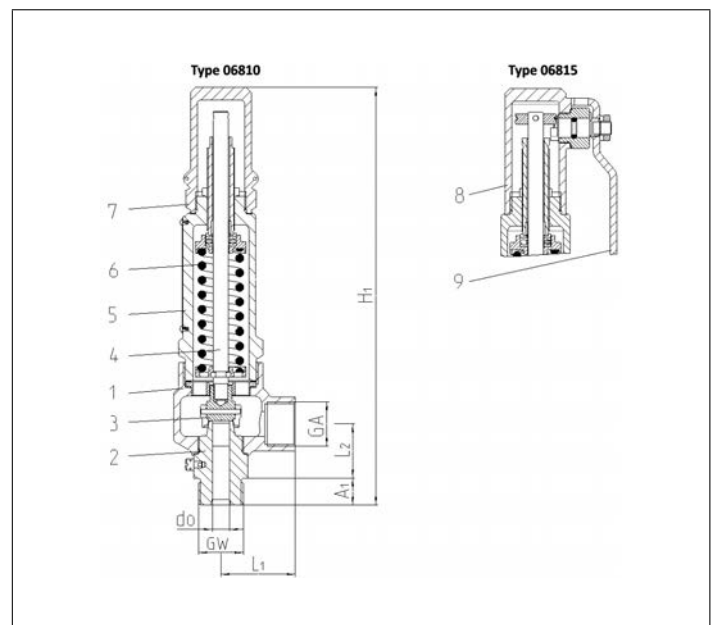

Type 06810, 06815	Technical data			
Nominal size	GW	1/2	1/2	3/4
Orifice	d ₀	10.0	10.0	10.0
Dimension code	.X.	1022	1023	1033
Set pressure range	bar	0.5-180	0.5-180	0.5-180
Outlet	GA	1/2	3/4	3/4
Height	H ₁	230	230	230
Length	L ₁	44	44	44
Length	L ₂	29	29	29
Length	A ₁	14	14	16
Weight 06810	ca. kg	1.8	1.8	1.8
Weight 06815	ca. kg	2.0	2.0	2.0
Coeff. of discharge gases, vapours	α _w	0.5	0.5	0.5
Coeff. of discharge fluids	α _w	0.5	0.5	0.5

Dimensions in mm.

Safety Valves

Type 06810, Type 06815



Discharge capacities

Calculation of flow rate acc. to AD2000-Merkblatt A2 / DIN EN ISO 4126-1

Medium:

A = Saturated steam in kg/h

B = Air in m³/h at 0°C and 1013,25 mbar

C = Water in kg/h at 20°C

The capacity indicated below is for a fully opened valve.

d_0 - orifice

A_0 - flow area

Set pressure in bar (g)	GW	1/2 & 3/4		
	d_0 (mm)	10.0		
	A_0 (mm ²)	78.5		
Medium	A	B	C	
0.5	32	39	1548	
1.0	44	55	2096	
2.0	67	85	2965	
3.0	90	115	3632	
4.0	112	145	4193	
5.0	134	174	4688	
6.0	156	204	5136	
7.0	178	234	5548	
8.0	200	264	5931	
9.0	222	294	6290	
10.0	244	324	6631	
12.0	288	383	7264	
14.0	331	443	7846	
16.0	375	502	8387	
18.0	418	561	8896	
20.0	462	627	9377	
25.0	570	777	10484	
30.0	680	935	11485	
35.0	788	1087	12405	
40.0	897	1249	13262	
45.0	1008	1401	14066	
50.0	1118	1567	14827	
60.0	1341	1889	16243	
70.0	1562	2216	17544	
80.0	1788	2545	18755	
90.0	2013	2878	19893	
100.0	2244	3212	20969	
120.0	2723	3876	22971	
130.0	2972	4197	23909	
140.0	-	4548	24811	
160.0	-	5213	26524	
180.0	-	5861	28133	

Pressure-Temperature Rating

Allowable operating pressure at the valve inlet and outlet
Safety valve type 06810.10 and 06815.10

--- allowable pressure / outlet PN 100 — allowable temperature / inlet PN 180

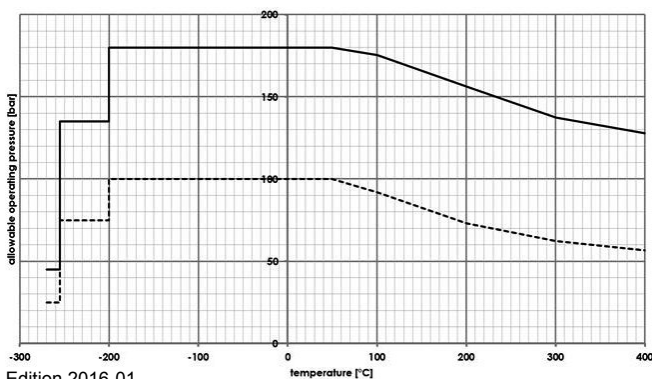

Edition 2016-01

Safety Valves

Type 06810, Type 06815



Safety Valves, angle type, stainless steel, type tested, TÜV-SV.1130. D/G/F

Standard safety valve
with soft valve seal, "cleaned and degreased for oxygen service"
closed bonnet, gastight cap or lifting device
Inlet: male thread type G (BSPP) acc. to ISO 228/1
Outlet: female thread type G (BSPP) acc. to ISO 228/1

Part No. 06810.X.000001L (Pmax 150.0 bar)
with gastight cap

Part No. 06815.X.000001L (Pmax 150.0 bar)
with lifting device

Available options - on request only:
· Flange-, NPT- or Tri-Clamp connection for in- and outlet



Applications:

Provided as safety device for protection against excessive pressure in gas cylinders and pressure vessels. Approved for gases, vapours and liquids. Working temperature: -270°C / -454°F (3K) up to +300°C / +572°F (573K)
Pressure-temperature must be observed, suitable for horizontal installation from 20 bar

Materials	DIN EN	ASME/ASTM
1 Outlet body	1.4408	A 351 CF8M
2 Inlet body	1.4571	A 276 Grade 316Ti
3 Disc	1.4571	A 276 Grade 316Ti
4 Seal	VESPEL	
5 Stem	1.4404	A 276 Grade 316L
6 Bonnet	1.4408	A 351 CF8M
7 Spring	1.4571	A 313 Grade 316Ti
8 Cap	1.4408	A 351 CF8M
9 Lifting cap	1.4408	A 351 CF8M
10 Lever	1.4301	A 276 Grade 304

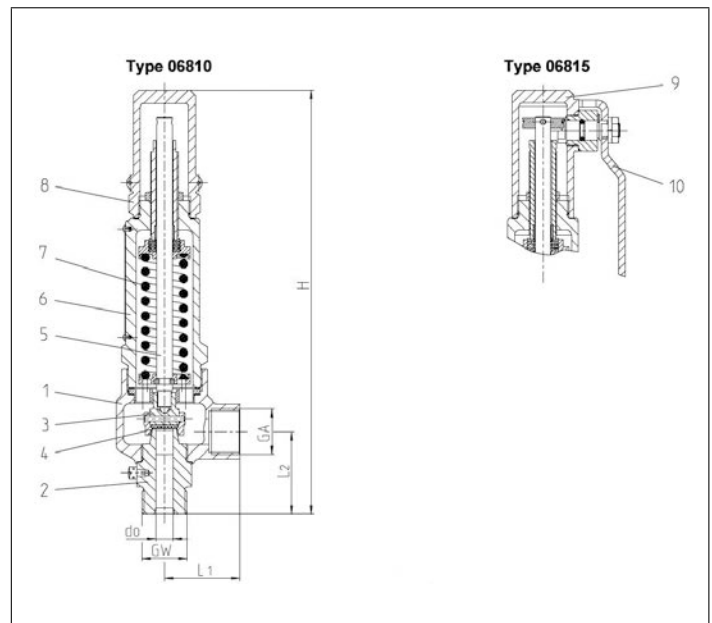

Standard marking acc. to Pressure Equipment Directive 97/23/EC (PED).



Type 06810, 06815	Technical Data			
D ₀	[mm]	10		
Inlet	GW	1/2	1/2	3/4
Outlet	GW	1/2	3/4	3/4
Dimension code	.X.	1022	1023	1033
Height	H1	244.0	244.0	246.0
Length	L1	44.0	44.0	44.0
Length	L2	43.0	43.0	45.0
Length	A1	14.0	14.0	16.0
Weight 06810	ca. kg	1.8	1.8	1.8
Weight 06815	ca. kg	2.0	2.0	2.0
Coeff. of discharge	$\alpha_w S/G/L$	0.50	0.50	0.50
Min. set pressure	bar-g	0.5	0.5	0.5
Max. set pressure	bar-g	150.0	150.0	150.0
Min. temperature	°C	-270	-270	-270
Max. temperature	°C	+300	+300	+300

Abmessungen in mm.

Safety Valves

Type 06810, Type 06815



Pressure-Temperature Rating

Maximum allowable set pressure safety valve Type 0681X

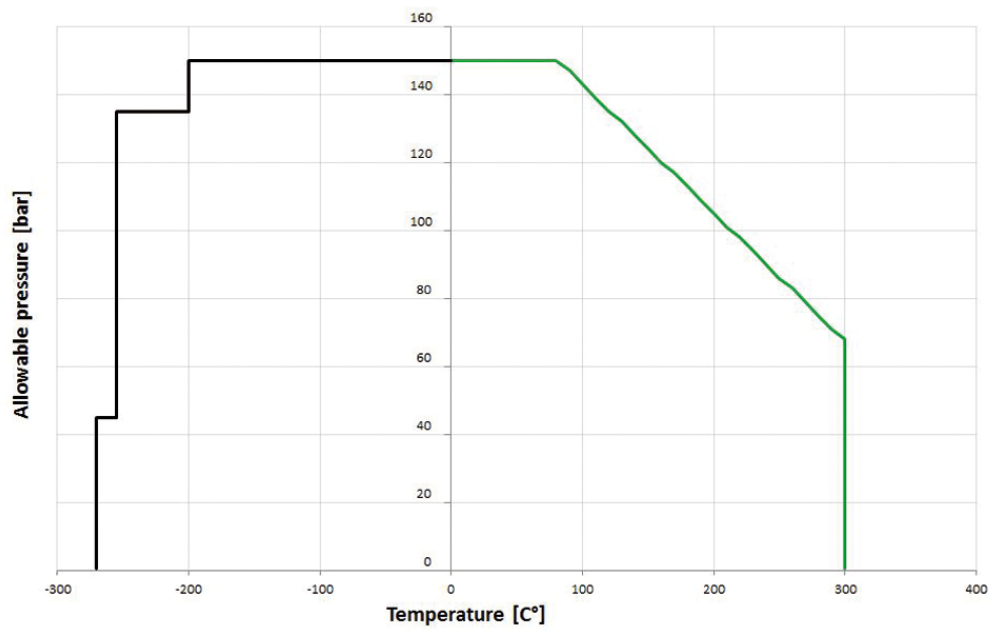

Safety Valves

Type 06810, Type 06815



Discharge capacities

Calculation of flow rate acc. to AD2000-Merkblatt A2 / DIN EN ISO 4126-1

Medium:

A = Saturated steam in kg/h

B = Air in m³/h at 0°C and 1013,25 mbar

C = Water in kg/h at 20°C

The capacity indicated below is for a fully opened valve.

d_0 - orifice

A_0 - flow area

Set pressure in bar (g)	GW		1/2, 3/4 & 1		
	d_0 (mm)		10.0		
	A_0 (mm ²)		78.5		
	Medium	A	B	C	
0.2		-	-	-	-
0.5		-	39	1548	
1.0		-	55	2096	
2.0		-	85	2965	
3.0		-	115	3632	
4.0		-	145	4193	
5.0		-	174	4688	
6.0		-	204	5136	
7.0		-	234	5548	
8.0		-	264	5931	
9.0		-	294	6290	
10.0		-	324	6631	
15.0		-	472	6947	
20.0		-	627	9377	
30.0		-	935	11485	
40.0		-	1249	13262	
50.0		-	1567	14827	
60.0		-	1889	16243	
65.0		-	2045	16906	
70.0		-	2216	-	
80.0		-	2545	-	
90.0		-	2878	-	
100.0		-	3212	-	
110.0		-	3544	-	
120.0		-	3876	-	
140.0		-	4548	-	
150.0		-	4871	-	

Safety Valves

Type 06850, Type 06855



Safety Valves, angle type, stainless steel, type tested, TÜV-SV.1130. S/G/L

Full lift / standard safety valve (D₀10 standard, D₀14 and D₀18 full lift)
 metal to metal seated, "cleaned and degreased for oxygen service"
 closed bonnet, gastight cap or lifting device
 Inlet: male thread type G (BSPP) acc. to ISO 228/1
 Outlet: female thread type G (BSPP) acc. to ISO 228/1

Part No. 06850.X.000000M (Pmax 20.0 bar)

Part No. 06850.X.000000H (Pmax 250.0 bar) stellited version
 with gastight cap

Part No. 06855.X.000000M (Pmax 20.0 bar)

Part No. 06855.X.000000H (Pmax 250.0 bar) stellited version
 with lifting device

Available options - on request only:

· Flange-, NPT- or Tri-Clamp connection for in- and outlet



Applications:

Provided as safety device for protection against excessive pressure in gas cylinders and pressure vessels. Approved for gases, vapours and liquids. Working temperature: -270°C / -454°F (3K) up to +400°C / +752°F (673K)

Pressure-temperature must be observed, suitable for horizontal installation from 20 bar

Materials	DIN EN	ASME/ASTM
1 Outlet body	1.4408	A 351 CF8M
2 Inlet body	1.4571	A 276 Grade 316Ti
3 Disc	1.4571	A 276 Grade 316Ti
4 Stem	1.4404	A 276 Grade 316L
5 Bonnet	1.4408	A 351 CF8M
6 Spring	1.4571	A 313 Grade 316Ti
7 Cap	1.4408	A 351 CF8M
8 Lifting cap	1.4408	A 351 CF8M
9 Lever	1.4301	A 276 Grade 304

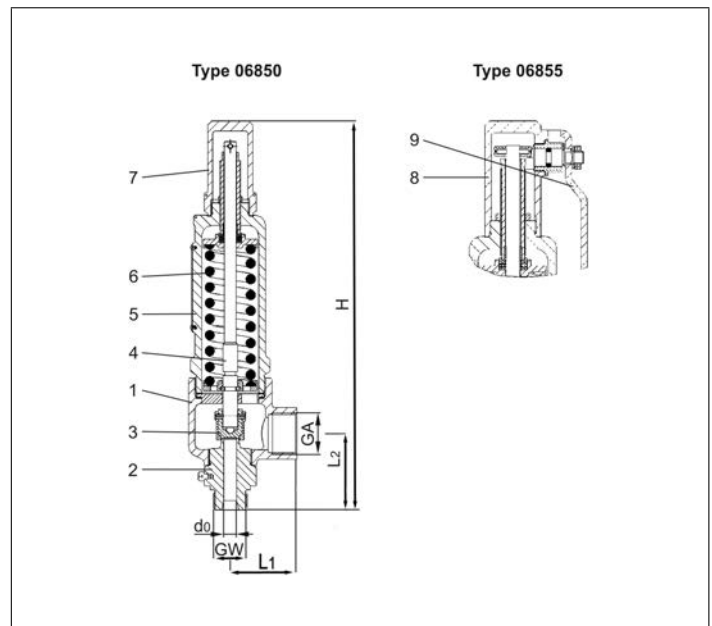

Standard marking acc. to Pressure Equipment Directive 97/23/EC (PED).



Type 06850, 06855	Technical data	Orifice											
		10			14								
Inlet	GW	1/2	3/4	1	1/2	1/2	1/2	3/4	3/4	3/4	1	1	1
Outlet	GW	1	1	1	1	1-1/4	1-1/2	1	1-1/4	1-1/2	1	1-1/4	1-1/2
Dimension code	.X.	1024	1034	1044	1424	1425	1426	1434	1435	1436	1444	1445	1446
Height	H1	305.0	307.0	309.0	308.5	308.5	308.5	310.5	310.5	310.5	312.5	312.5	312.5
Length	L1	53.0	53.0	53.0	55.0	55.0	55.0	55.0	55.0	55.0	55.0	55.0	55.0
Length	L2	44.5	44.5	44.5	48.2	48.2	48.2	48.2	48.2	48.2	48.2	48.2	48.2
Weight 06850	ca. kg	3.2	3.2	3.2	3.4	3.4	3.4	3.4	3.4	3.4	3.4	3.4	3.4
Weight 06855	ca. kg	3.4	3.4	3.4	3.6	3.6	3.6	3.6	3.6	3.6	3.6	3.6	3.6
coefficient of discharge	$\alpha_w D_{G/F}$	0.84 / 0.68	0.84 / 0.68	0.84 / 0.68	0.70 / *	0.70 / *	0.70 / *	0.70 / *	0.70 / *	0.70 / *	0.70 / *	0.70 / *	0.70 / *
Min. set pressure	bar-g	0.5	0.5	0.5	0.2	0.2	0.2	0.2	0.2	0.2	0.2	0.2	0.2
Max. set pressure	bar-g	250.0	250.0	250.0	50.0	50.0	50.0	200.0	200.0	200.0	200.0	200.0	200.0
Min. temperature	°C	-270	-270	-270	-270	-270	-270	-270	-270	-270	-270	-270	-270
Max. temperature	°C	+400	+400	+400	+400	+400	+400	+400	+400	+400	+400	+400	+400

Dimensions in mm. * 0.20-11.50 bar=0.50 / 11.51-74.99 bar=0.49 / 75.00-200.00 bar=0.46

Type 06850, 06855		Technical data					
Orifice	[mm]	18					
Inlet	GW	1	1	1-1/4	1-1/4	1-1/2	1-1/2
Outlet	GW	1-1/2	2	1-1/2	2	1-1/2	2
Dimension code	.X.	1846	1847	1856	1857	1866	1867
Height	H1	306.0	306.0	306.0	306.0	306.0	306.0
Length	L1	60.0	63.0	60.0	63.0	60.0	63.0
Length	L2	49.0	53.0	49.0	53.0	49.0	53.0
Weight 06850	ca. kg	3.9	4.1	3.9	4.1	4.0	4.2
Weight 06855	ca. kg	4.1	4.3	4.1	4.3	4.2	4.4
coefficient of discharge	$\alpha_w D, G / F$	0.76 / 0.50	0.76 / 0.50	0.76 / 0.50	0.76 / 0.50	0.76 / 0.50	0.76 / 0.50
Min. set pressure	bar-g	0.5	0.5	0.5	0.5	0.5	0.5
Max. set pressure	bar-g	110.0	110.0	110.0	110.0	110.0	110.0
Min. temperature	°C	-270	-270	-270	-270	-270	-270
Max. temperature	°C	+400	+400	+400	+400	+400	+400

Abmessungen in mm.

Pressure-Temperature Rating

Maximum allowable set pressure safety valve Type 0685X

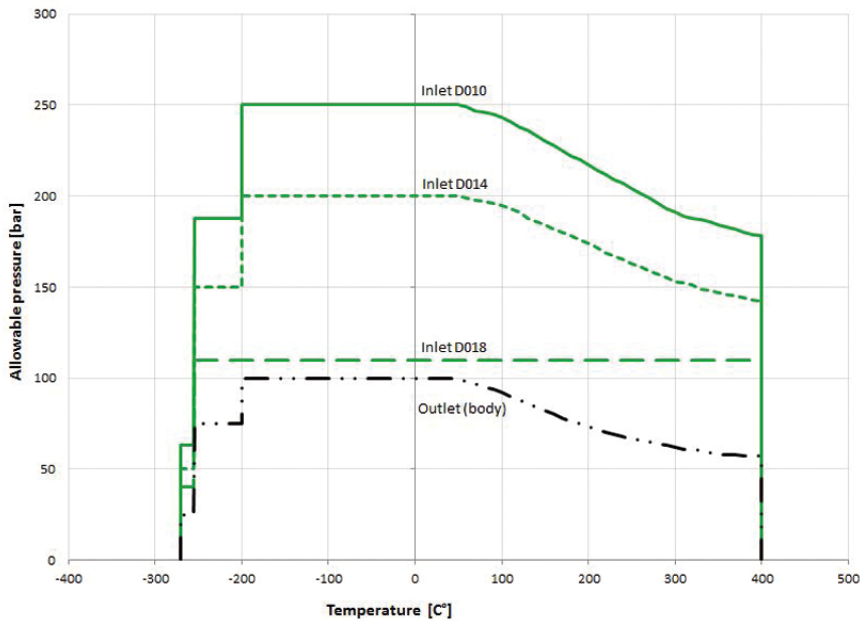

Safety Valves

Type 06850, Type 06855



Discharge capacities

Calculation of flow rate acc. to AD2000-Merkblatt A2 / DIN EN ISO 4126-1

Medium:

A = Saturated steam in kg/h

B = Air in m³/h at 0°C and 1013,25 mbar

C = Water in kg/h at 20°C

The capacity indicated below is for a fully opened valve.

d₀ - orifice

A₀ - flow area

Set pressure in bar (g)	GW	1/2, 3/4 & 1			1/2, 3/4 & 1			1, 1-1/4 & 1-1/2		
	d ₀ (mm)	10.0			14.0			18.0		
	A ₀ (mm ²)	78.5			153.9			254.0		
	Medium	A	B	C	A	B	C	A	B	C
0.2	-	-	-	53	56	2146	-	-	-	
0.5	46	56	2075	80	96	3035	127	152	5017	
1.0	69	88	2851	112	142	4110	186	236	6794	
2.0	112	142	4033	179	228	5812	309	393	9608	
3.0	151	194	4939	239	306	7118	428	549	11767	
4.0	189	243	5703	297	383	8220	534	688	13588	
5.0	226	293	6377	356	461	9190	639	828	15192	
6.0	264	343	6985	414	539	10067	743	967	16642	
7.0	300	393	7545	471	616	10874	846	1106	17975	
8.0	337	444	8066	529	696	11625	949	1249	19216	
9.0	374	494	8555	586	773	12330	1052	1388	20382	
10.0	411	544	9018	643	853	12997	1154	1530	21485	
15.0	592	794	11045	926	1242	15599	1663	2229	26313	
20.0	774	1053	12754	1209	1646	18013	2170	2955	30384	
30.0	1139	1572	15620	1779	2454	22061	3193	4405	37213	
40.0	1509	2098	18036	2356	3275	25474	4228	5878	42970	
50.0	1882	2633	20165	2937	4109	28481	5271	7375	48042	
60.0	2256	3175	22090	3519	4953	31199	6317	8891	52627	
70.0	2630	3723	23860	4103	5808	33699	7365	10424	56844	
80.0	3008	4276	25508	4693	6671	33820	8423	11973	60769	
90.0	3393	4835	27055	5293	7542	35872	9501	13536	64455	
100.0	3790	5396	28518	5912	8417	37812	10611	15107	67942	
110.0	4202	5931	29910	6554	9251	39658	11763	16603	71258	
120.0	4629	6512	31240	7220	10157	41421	-	-	-	
140.0	5519	7642	33744	8608	11918	44740	-	-	-	
160.0	6447	8758	36073	-	13658	47829	-	-	-	
180.0	7575	9846	38262	-	15356	50731	-	-	-	
200.0	-	10898	40331	-	16995	53475	-	-	-	
220.0	-	11930	42300	-	-	-	-	-	-	
240.0	-	12982	44181	-	-	-	-	-	-	
250.0	-	13521	45092	-	-	-	-	-	-	

Safety Valves

Type 06850, Type 06855



Safety Valves, angle type, stainless steel, type tested, TÜV-SV.1130. S/G/L

standard safety valve
with soft valve seal, "cleaned and degreased"
closed bonnet, gastight cap or lifting device
Inlet: male thread type G (BSPP) acc. to ISO 228/1
Outlet: female thread type G (BSPP) acc. to ISO 228/1

Part No. 06850.X.000001L (Pmax 150.0 bar)
with gastight cap

Part No. 06855.X.000001L (Pmax 150.0 bar)
with lifting device

Available options - on request only:
· Flange-, NPT- or Tri-Clamp connection for in- and outlet



Applications:

Provided as safety device for protection against excessive pressure in gas cylinders and pressure vessels. Approved for gases, vapours and liquids. Working temperature: -270°C / -454°F (3K) up to +300°C / +572°F (573K)
Pressure-temperature must be observed, suitable for horizontal installation from 20 bar

Materials	DIN EN	ASME/ASTM
1 Outlet body	1.4408	A 351 CF8M
2 Inlet body	1.4571	A 276 Grade 316Ti
3 Disc	1.4571	A 276 Grade 316Ti
4 Seal	VESPEL	
5 Stem	1.4404	A 276 Grade 316L
6 Bonnet	1.4408	A 351 CF8M
7 Spring	1.4571	A 313 Grade 316Ti
8 Cap	1.4408	A 351 CF8M
9 Lifting cap	1.4408	A 351 CF8M
10 Lever	1.4301	A 276 Grade 304

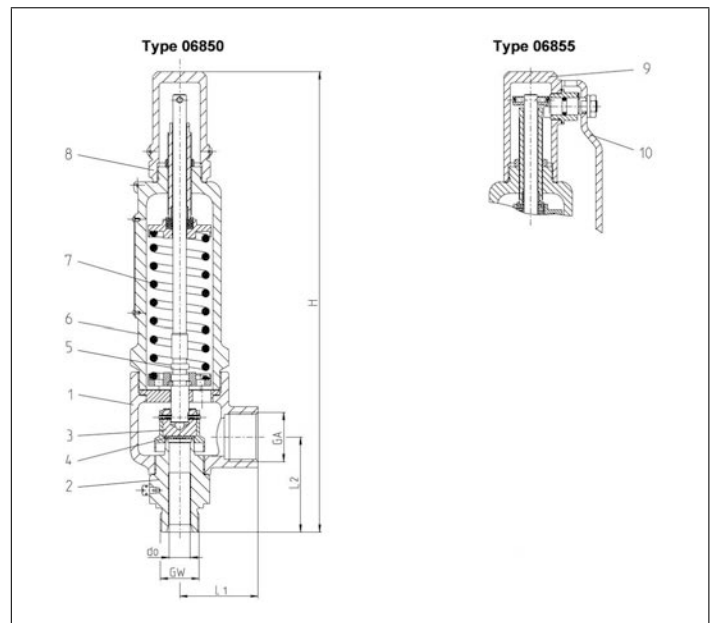

Standard marking acc. to Pressure Equipment Directive 97/23/EC (PED).



Typ 06850, 06855	Technical data													
	Orifice	[mm]	10			14								
Inlet	GW	1/2	3/4	1	1/2	1/2	1/2	3/4	3/4	3/4	1	1	1	
Outlet	GW	1	1	1	1	1-1/4	1-1/2	1	1-1/4	1-1/2	1	1-1/4	1-1/2	
Dimension code	.X.	1024	1034	1044	1424	1425	1426	1434	1435	1436	1444	1445	1446	
Height	H1	305.0	307.0	309.0	308.5	308.5	308.5	310.5	310.5	310.5	312.5	312.5	312.5	
Length	L1	53.0	53.0	53.0	55.0	55.0	55.0	55.0	55.0	55.0	55.0	55.0	55.0	
Length	L2	58.5	60.5	62.5	62.2	62.2	62.2	64.2	64.2	64.2	66.2	66.2	66.2	
Weight 06850	ca. kg	3.2	3.2	3.2	3.4	3.4	3.4	3.4	3.4	3.4	3.4	3.4	3.4	
Weight 06855	ca. kg	3.4	3.4	3.4	3.6	3.6	3.6	3.6	3.6	3.6	3.6	3.6	3.6	
Coefficient of discharge	$\alpha_w D, G / F$	0.84 / 0.68	0.84 / 0.68	0.84 / 0.68	0.70 / *	0.70 / *	0.70 / *	0.70 / *	0.70 / *	0.70 / *	0.70 / *	0.70 / *	0.70 / *	
Min. set pressure	bar-g	0.5	0.5	0.5	0.2	0.2	0.2	0.2	0.2	0.2	0.2	0.2	0.2	
Max. set pressure	bar-g	150.0	150.0	150.0	50.0	50.0	50.0	120.0	120.0	120.0	120.0	120.0	120.0	
Min. temperature	°C	-270	-270	-270	-270	-270	-270	-270	-270	-270	-270	-270	-270	
Max. temperature	°C	+300	+300	+300	+300	+300	+300	+300	+300	+300	+300	+300	+300	

Dimensions in mm. * 0.20-11.50 bar=0.50 / 11.51-74.99 bar=0.49 / 75.00-120.00 bar=0.46

Type 06850, 06855		Technical data					
Orifice	[mm]	18					
Inlet	GW	1	1	1-1/4	1-1/4	1-1/2	1-1/2
Outlet	GW	1-1/2	2	1-1/2	2	1-1/2	2
Dimension code	.X.	1846	1847	1856	1857	1866	1867
Height	H1	306.0	306.0	306.0	306.0	306.0	306.0
Length	L1	60.0	63.0	60.0	63.0	60.0	63.0
Length	L2	49.0	53.0	49.0	53.0	49.0	53.0
Weight 06850	ca. kg	3.9	4.1	3.9	4.1	4.0	4.2
Weight 06855	ca. kg	4.1	4.3	4.1	4.3	4.2	4.4
Coefficient of discharge	$\alpha_w D, G / F$	0.76 / 0.50	0.76 / 0.50	0.76 / 0.50	0.76 / 0.50	0.76 / 0.50	0.76 / 0.50
Min. set pressure	bar-g	0.5	0.5	0.5	0.5	0.5	0.5
Max. set pressure	bar-g	110.0	110.0	110.0	110.0	110.0	110.0
Min. temperature	°C	-270	-270	-270	-270	-270	-270
Max. temperature	°C	+300	+300	+300	+300	+300	+300

Abmessungen in mm.

Pressure-Temperature Rating

Maximum allowable set pressure safety valve Type 0685X

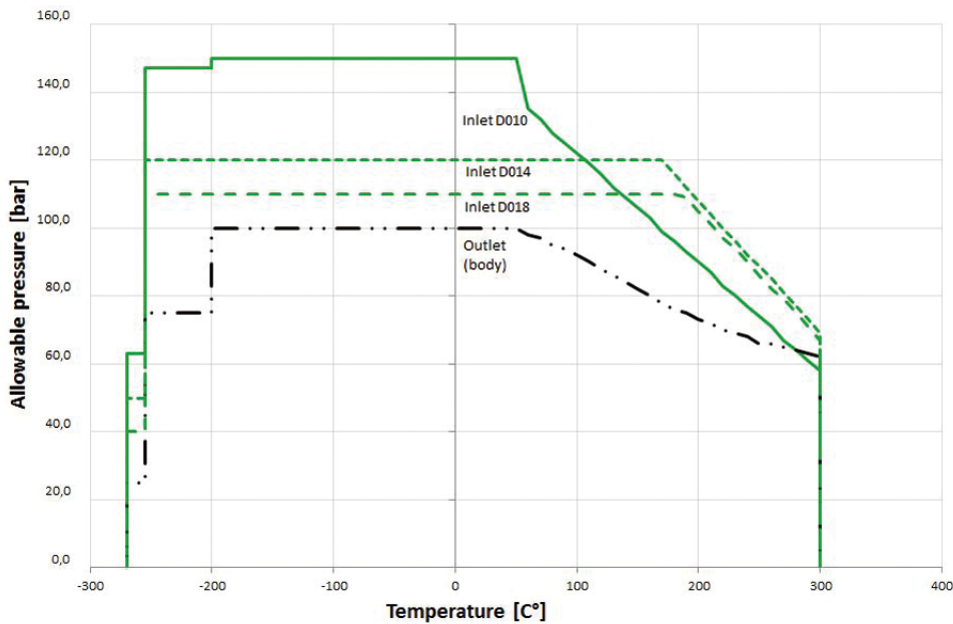

Safety Valves

Type 06850, Type 06855



Discharge capacities

Calculation of flow rate acc. to AD2000-Merkblatt A2 / DIN EN ISO 4126-1

Medium:

A = Saturated steam in kg/h

B = Air in m³/h at 0°C and 1013,25 mbar

C = Water in kg/h at 20°C

The capacity indicated below is for a fully opened valve.

d₀ - orifice

A₀ - flow area

Set pressure in bar (g)	GW	1/2, 3/4 & 1			1/2, 3/4 & 1			1, 1-1/4 & 1-1/2		
	d ₀ (mm)	10.0			14.0			18.0		
	A ₀ (mm ²)	78.5			153.94			254.0		
	Medium	A	B	C	A	B	C	A	B	C
0.2	-	-	-	-	-	56	2146	-	-	-
0.5	-	56	2075	-	-	96	3035	-	152	5017
1.0	-	88	2851	-	-	146	4110	-	241	6794
2.0	-	142	4033	-	-	235	5812	-	406	9608
3.0	-	194	4939	-	-	317	7118	-	569	11767
4.0	-	243	5703	-	-	398	8220	-	714	13588
5.0	-	293	6377	-	-	480	9190	-	861	15192
6.0	-	343	6985	-	-	561	10067	-	1007	16642
7.0	-	393	7545	-	-	642	10874	-	1152	17975
8.0	-	444	8066	-	-	725	11625	-	1302	19216
9.0	-	494	8555	-	-	806	12330	-	1448	20382
10.0	-	544	9018	-	-	890	12997	-	1597	21485
15.0	-	794	11045	-	-	1297	15590	-	2328	26298
20.0	-	1053	12754	-	-	1721	18013	-	3089	30384
30.0	-	1572	15620	-	-	2568	22061	-	4609	37213
40.0	-	2098	18036	-	-	3427	25747	-	6152	42970
45.0	-	2355	19131	-	-	3846	27019	-	6903	45577
50.0	-	2633	20165	-	-	4301	28481	-	7720	-
60.0	-	3175	22090	-	-	5186	-	-	9307	-
65.0	-	3435	22992	-	-	5611	-	-	10071	-
70.0	-	3723	-	-	-	6081	-	-	10913	-
80.0	-	4276	-	-	-	6985	-	-	12536	-
90.0	-	4835	-	-	-	7897	-	-	14174	-
100.0	-	5396	-	-	-	8814	-	-	15819	-
110.0	-	5931	-	-	-	9687	-	-	17387	-
120.0	-	6512	-	-	-	10637	-	-	-	-
140.0	-	7642	-	-	-	-	-	-	-	-
150.0	-	8184	-	-	-	-	-	-	-	-

*not suitable for water steam!

Safety Valves

Type 55335 - Insect protection screen



Insect protection screen for safety valves

to protect the outlet from insects etc.

wire gauge 0.56mm, mesh size 2.0mm,

"cleaned and degreased for oxygen service"

Part No. 55335.X.0765

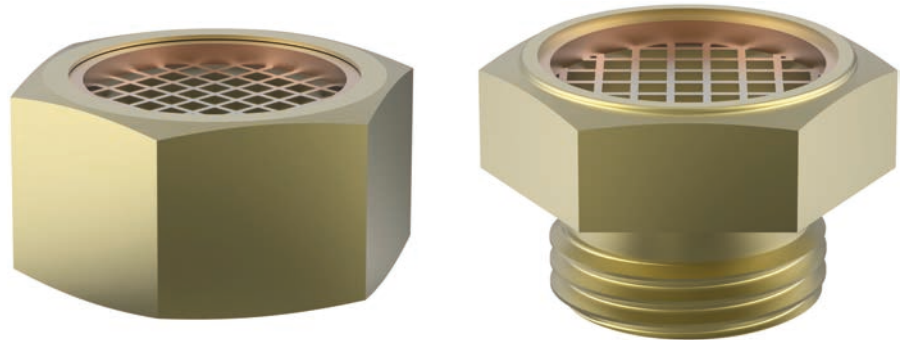

Applications:

Provided as safety device in the outlet of the safety valve against unauthorized ingress by insects, small animals or equivalent, which run a potential threat to the proper response characteristics of the valve.

Materials	DIN EN	ASME/ASTM
1 Copper ring	CW024A	C 106 C12200
2 Screen	1.4301	A 276 Grade 304
3 Union type	CW614N	B 283 UNS C38500

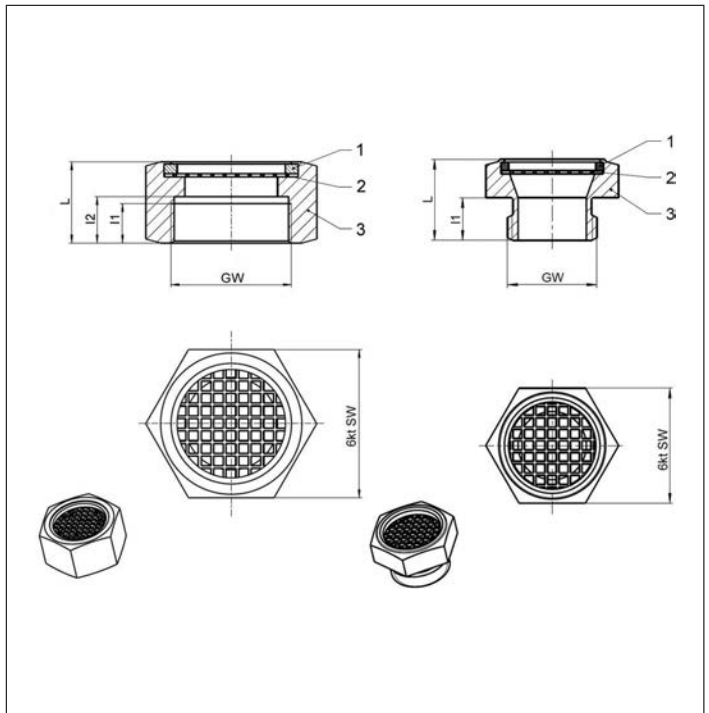

Type 55335	Technical Data							
Nominal size	GW	3/8	3/8	1/2	1/2	1/2	1	26x1.5
Thread type		BSPT (R)	NPT	BSPT (R)	NPT	BSPP (G)	BSPP (G)	M
Dimension code	.X.	0140	0149	0150	0147	0141	0102	0148
Height	L	19.0	27.0	27.0	27.0	19.0	21.5	17.5
Length	l ₁	10.0	17.0	17.0	17.0	10.0	12.0	8.5
Length	l ₂	-	-	-	-	-	-	10.0
Wrench size across flats	SW	27	27	27	27	27	41	32

Abmessungen in mm.

Edition 2016-01

Overflow Valves

Type 06386



Cryogenic Overflow Valves, angle type, bronze, PN40, not type tested

with adjusting device, metal to metal seated, closed bonnet

Inlet: male thread type G (BSPP) acc. to ISO 228/1

Outlet: female thread type G (BSPP) acc. to ISO 228/1

"cleaned and degreased for oxygen service"

Part No. 06386.X.9005 (0.5 up to 1.5 bar)

Part No. 06386.X.9003 (1.0 up to 4.0 bar)

Part No. 06386.X.9001 (3.0 up to 8.0 bar)

Part No. 06386.X.9002 (7.0 up to 17.0 bar)

Part No. 06386.X.9004 (16.0 up to 21.0 bar)

Part No. 06386.X.9007 (21.0 up to 28.0 bar)

Part No. 06386.X.9006 (28.0 up to 36.0 bar)

Available options - on request only:

- other spring ranges acc. to customer specification



Applications:

Provided as overflow valve for protection against excessive pressure in pipe systems and pressure vessels, which are not subject to approval.

Working temperature: -196°C / -321°F (77K) up to +185°C / +365°F (458K)

Materials	DIN EN	ASTM
1 Outlet body	CC491K	B 62 UNS C83600
2 Inlet body	1.4301	A 276 Grade 304
3 Disc	1.4541	A 276 Grade 321
4 Guide plate	CW453K	B 103 UNS C52100
5 Stem	CW453K	B 103 UNS C52100
6 Spring	1.4571	A 313 Grade 316Ti
7 Bonnet	1.4305	A 314 Grade 303
8 Spring clamp	CW614N	B 283 UNS C38500
9 Adjusting screw	CW614N	B 283 UNS C38500
10 Plug	CW614N	B 283 UNS C38500
11 Nut	CW614N	B 283 UNS C38500
12 Closing cap	CW614N	B 283 UNS C38500

Important: Adjusting ranges of springs are marked with a label on the bonnet.

Not to use as equipment with safety function acc. to Pressure Equipment Directive 97/23/EC (PED) (No CE marking).

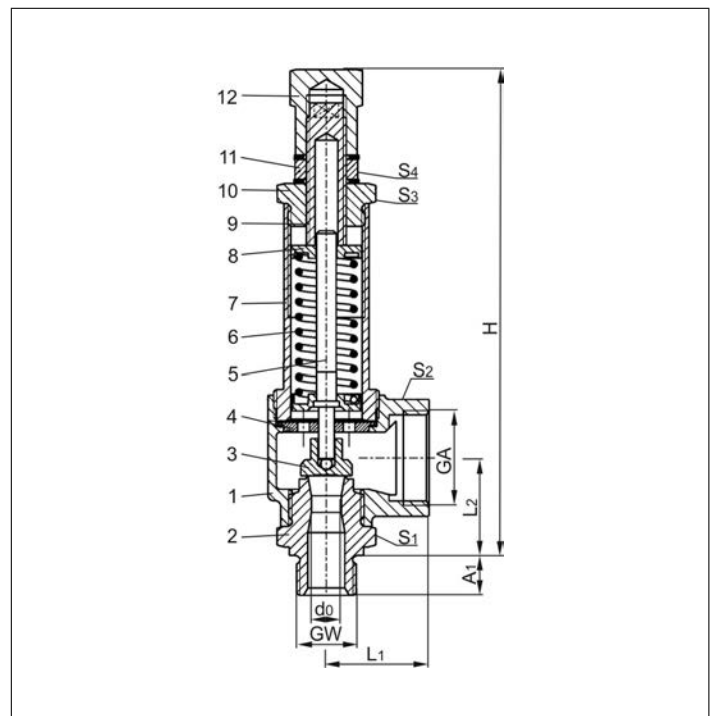

Type 06386	Technical data		
Nominal size	GW	1/2	3/4
Orifice	d ₀	10.5	10.5
Dimension code	.X.	1004	1006
Outlet	GA	1	1
Height	H	171	171
Length	L ₁	36	36
Length	L ₂	34	34
Length	A ₁	14	16
Wrench size across flats	S ₁	30	32
Wrench size across flats	S ₂	41	41
Wrench size across flats	S ₃	30	30
Wrench size across flats	S ₄	22	22
Weight	ca. kg	0.78	0.81

Dimensions in mm.

Overflow Valves

Type 06386



Discharge capacities

Calculation of flow rate acc. to AD2000-Merkblatt A2 / DIN EN ISO 4126-1

Medium:

Air in m³/h at 0°C and 1013.25 mbar

The capacity indicated below is for 10% pressure increase.

d₀ - orifice

A₀ - flow area

Set pressure in bar (g)	GW	1/2 & 3/4						
	d ₀ (mm) A ₀ (mm ²) Medium	Air						
Pressure range in bar		0.5 - 1.5	1.0 - 4.0	3.0 - 8.0	7.0 - 17.0	16.0 - 21.0	21.0 - 28.0	28.0 - 36.0
0.5	8	-	-	-	-	-	-	-
1.0	11	6	-	-	-	-	-	-
1.5	14	9	-	-	-	-	-	-
2.0	-	12	-	-	-	-	-	-
3.0	-	21	10	-	-	-	-	-
4.0	-	32	25	-	-	-	-	-
5.0	-	-	48	-	-	-	-	-
6.0	-	-	76	-	-	-	-	-
7.0	-	-	107	82	-	-	-	-
8.0	-	-	144	104	-	-	-	-
9.0	-	-	-	128	-	-	-	-
10.0	-	-	-	155	-	-	-	-
11.0	-	-	-	177	-	-	-	-
12.0	-	-	-	217	-	-	-	-
13.0	-	-	-	248	-	-	-	-
14.0	-	-	-	280	-	-	-	-
15.0	-	-	-	319	-	-	-	-
16.0	-	-	-	361	186	-	-	-
17.0	-	-	-	409	220	-	-	-
18.0	-	-	-	-	263	-	-	-
19.0	-	-	-	-	304	-	-	-
20.0	-	-	-	-	339	-	-	-
21.0	-	-	-	-	383	227	-	-
22.0	-	-	-	-	-	244	-	-
24.0	-	-	-	-	-	278	-	-
25.0	-	-	-	-	-	296	-	-
26.0	-	-	-	-	-	314	-	-
28.0	-	-	-	-	-	353	431	-
30.0	-	-	-	-	-	-	461	-
32.0	-	-	-	-	-	-	491	-
34.0	-	-	-	-	-	-	521	-
35.0	-	-	-	-	-	-	536	-
36.0	-	-	-	-	-	-	583	-

GW	1/2 & 3/4
Part No. spring	Pressure range of springs in bar
55345.0114.1767	0.5 - 1.5
55345.0263.0767	1.0 - 4.0
55345.0118.1767	3.0 - 8.0
55345.0119.1767	7.0 - 17.0
55345.0120.1767	16.0 - 21.0
55345.0233.0767	21.0 - 28.0
55345.0237.0767	28.0 - 36.0

Overflow Valves

Type 06381



Cryogenic Safety Valves, angle type, stainless steel, PN40, not type tested

metal to metal seated, closed bonnet,

Inlet: male thread type G (BSPP) acc. to ISO 228/1

Outlet: female thread type G (BSPP) acc. to ISO 228/1

"cleaned and degreased for oxygen service"

Part No. 06381.X.9005 (0.5 up to 1.5 bar)

Part No. 06381.X.9003 (1.0 up to 4.0 bar)

Part No. 06381.X.9001 (3.0 up to 8.0 bar)

Part No. 06381.X.9002 (7.0 up to 17.0 bar)

Part No. 06381.X.9004 (16.0 up to 21.0 bar)

Part No. 06381.X.9007 (21.0 up to 28.0 bar)

Part No. 06381.X.9006 (28.0 up to 36.0 bar)

Available options - on request only:

· other spring ranges acc. to customer specification



Applications:

Provided as overflow valve for protection against excessive pressure in pipe systems and pressure vessels, which are not subject to approval.

Working temperature: -196°C / -321°F (77K) up to +185°C / +365°F (458K)

Materials	DIN EN	ASTM
1 Outlet body	1.4308	A 351 CF8
2 Inlet body	1.4301	A 276 Grade 304
3 Disc	1.4541	A 276 Grade 321
4 Guide plate	1.4301	A 276 Grade 304
5 Stem	1.4571	A 276 Grade 316Ti
6 Spring	1.4571	A 313 Grade 316Ti
7 Bonnet	1.4308	A 351 CF 8
8 Spring Clamp	1.4301	A 276 Grade 304
9 Adjusting screw	1.4571	A 276 Grade 316Ti
10 Cap	1.4301	A 276 Grade 304

Important: Adjusting ranges of springs are marked with a label on the bonnet.

Not to use as equipment with safety function acc. to Pressure Equipment Directive 97/23/EC (PED) (No CE marking).

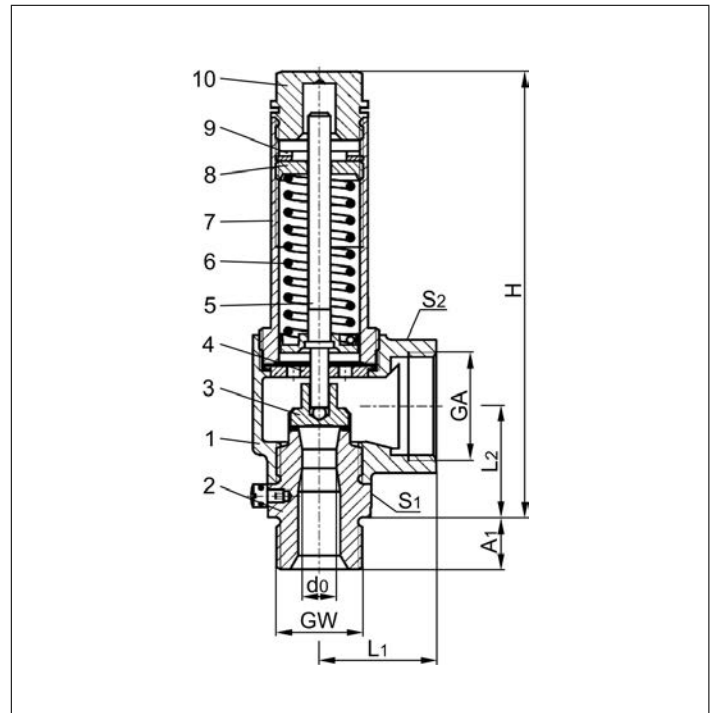

Type 06381	Technical data		
Nominal size	GW	1/2	3/4
Orifice	d ₀	10.5	10.5
Dimension code	.X.	1004	1006
Outlet	GA	1	1
Height	H	139	139
Length	L ₁	36	36
Length	L ₂	34	34
Length	A ₁	14	16
Wrench size across flats	S ₁	30	32
Wrench size across flats	S ₂	41	41
Weight	ca. kg	0.77	0.79

Overflow Valves

Type 06381



Discharge capacities

Calculation of flow rate acc. to AD2000-Merkblatt A2 / DIN EN ISO 4126-1

Medium:

Air in m³/h at 0°C and 1013.25 mbar

The capacity indicated below is for 10% pressure increase.

d₀ - orifice

A₀ - flow area

Set pressure in bar (g)	GW	1/2 & 3/4						
	d ₀ (mm)	10.5						
	A ₀ (mm ²)	86.6						
	Medium	Air						
Pressure range in bar	0.5 - 1.5	1.0 - 4.0	3.0 - 8.0	7.0 - 17.0	16.0 - 21.0	21.0 - 28.0	28.0 - 36.0	
0.5	8	-	-	-	-	-	-	
1.0	11	6	-	-	-	-	-	
1.5	14	9	-	-	-	-	-	
2.0	-	12	-	-	-	-	-	
3.0	-	21	10	-	-	-	-	
4.0	-	32	25	-	-	-	-	
5.0	-	-	48	-	-	-	-	
6.0	-	-	76	-	-	-	-	
7.0	-	-	107	82	-	-	-	
8.0	-	-	144	104	-	-	-	
9.0	-	-	-	128	-	-	-	
10.0	-	-	-	155	-	-	-	
11.0	-	-	-	177	-	-	-	
12.0	-	-	-	217	-	-	-	
13.0	-	-	-	248	-	-	-	
14.0	-	-	-	280	-	-	-	
15.0	-	-	-	319	-	-	-	
16.0	-	-	-	361	186	-	-	
17.0	-	-	-	409	220	-	-	
18.0	-	-	-	-	263	-	-	
19.0	-	-	-	-	304	-	-	
20.0	-	-	-	-	339	-	-	
21.0	-	-	-	-	383	227	-	
22.0	-	-	-	-	-	244	-	
24.0	-	-	-	-	-	278	-	
25.0	-	-	-	-	-	296	-	
26.0	-	-	-	-	-	314	-	
28.0	-	-	-	-	-	353	431	
30.0	-	-	-	-	-	-	461	
32.0	-	-	-	-	-	-	491	
34.0	-	-	-	-	-	-	521	
35.0	-	-	-	-	-	-	536	
36.0	-	-	-	-	-	-	583	

GW	1/2 & 3/4
Part No. spring	Pressure range of springs in bar
55345.0114.1767	0.5 - 1.5
55345.0263.0767	1.0 - 4.0
55345.0118.1767	3.0 - 8.0
55345.0119.1767	7.0 - 17.0
55345.0120.1767	16.0 - 21.0
55345.0233.0767	21.0 - 28.0
55345.0237.0767	28.0 - 36.0

Changeover Valves

Type 06510 - Divertor Valve



Cryogenic Divertor Valves, bronze, PN50
for the installation of two safety valves,
provided for bursting disc connections,
"cleaned and degreased for oxygen service"

Part No. 06510.X.0000

Female thread connection (G) acc. to ISO 228/1

Part No. 06510.X.6***

Female thread connection NPT acc. to ANSI B 1.20.1

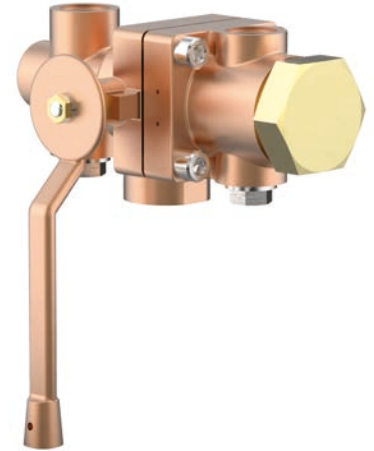

Available Options - on request only:

- Two extra test connections 1/4" edgeways
- Inlet: female thread (GW) 3/4"
- Outlet GA₁ with installed locking sleeve for easy positioning of safety valves
- Combination of different outlet threads GA₁ - GA₂
- **Safety lock (Part No. 55394.0043.0765)**

Applications:

Approved for air gases, vapours and cryogenic liquefied gases incl. LNG.
Working temperature: -196°C / -321°F (77K) up to +120°C / +248°F (393K)

Materials	DIN EN	ASTM
1 Body I	CC491K	B 62 UNS C83600
2 Body II	CC491K	B 62 UNS C83600
3 Ball	1.4571	A 276 Grade 316Ti
4 Seat rings	PCTFE	
5 Bush	CW614N	B 283 UNS C38500
6 Spring plates	1.4571	A 313 Grade 316Ti
7 Spring clamp	CW614N	B 283 UNS C38500
8 Thread ring	CW614N	B 283 UNS C38500
9 Plug	CW614N	B 283 UNS C38500
10 Stem	1.4301	A 276 Grade 304
11 Gland packing	Graphite / PTFE	
12 Lever	CC491K	B 62 UNS C83600

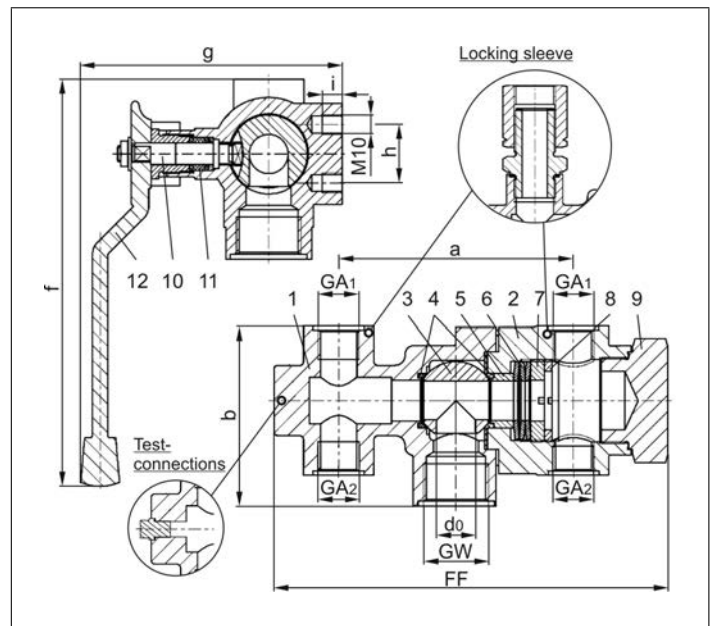

Type 06510 - Standard design	Technical Data		
Nominal Size	DN	20	20
Dimension code	.X.	2004	2006
Flow diameter	d ₀	20	20
Inlet	GW	1	1
Outlet	GA ₁	1/2	3/4
Outlet	GA ₂	1/2	1/2
Face-to-face dimension	FF	201	201
Length	a	120	120
Height	b	92	92
Length	f	208	208
Length	g	134	134
Length	h	30	30
Thread depth	i	10	10
Weight	ca. kg	4.8	4.7
Kvs - Value, one side open	m ³ /h	7.7	7.7
Cv - Value, one side open	gal /min	9.2	9.2

Dimensions in mm.

Important:

The valves must be fixed at the provided threads M10.

Changeover Valves

Type 06510 - Divertor Valve



Cryogenic Divertor Valves, bronze, PN50

for the installation of two safety valves,
provided for bursting disc connections,
"cleaned and degreased for oxygen service"

Artikel-Nr. 06510.X.0008

Inlet: union type braze fitting for pipe outside diameter 26.9mm

Outlet: female thread connection (G) acc. to ISO 228/1

Artikel-Nr. 06510.X.000*

Inlet: union type butt weld fitting, when order please indicate pipe diameter

Outlet: female thread connection (G) acc. to ISO 228/1

Artikel-Nr. 06510.X.6026

Inlet: union type butt weld fitting for pipe 33.4mm S10

Outlet: female thread connection NPT acc. to ANSI B 1.20.1

Available options - on request only:

- Two extra test connections 1/4" edgeways
- Inlet: union type braze or butt weld fitting for other pipe diameter
- Outlet GA₁ with installed locking sleeve for easy positioning of safety valves
- Combination of different outlet threads GA₁ - GA₂
- **Safety lock (Part No. 55394.0043.0765)**

Applications:

Approved for air gases, vapours and cryogenic liquefied gases incl. LNG.

Working temperature: -196°C / -321°F (77K) up to +120°C / +248°F (393K)

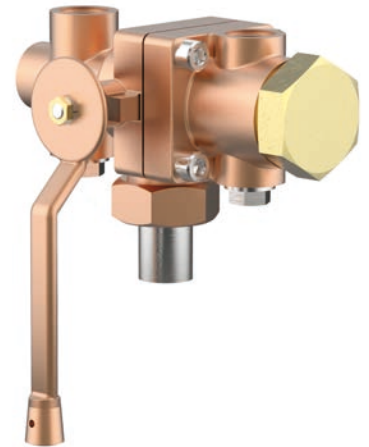

Materials	DIN EN	ASTM
1 Body I	CC491K	B 62 UNS C83600
2 Body II	CC491K	B 62 UNS C83600
3 Ball	1.4571	A 276 Grade 316Ti
4 Seat rings	PCTFE	
5 Bush	CW614N	B 283 UNS C38500
6 Spring plates	1.4571	A 313 Grade 316Ti
7 Spring clamp	CW614N	B 283 UNS C38500
8 Thread ring	CW614N	B 283 UNS C38500
9 Plug	CW614N	B 283 UNS C38500
10 Stem	1.4301	A 276 Grade 304
11 Gland packing	Graphit / PTFE	
12 Lever	CC491K	B 62 UNS C83600
13 Braze fitting	CC493K	B 505 UNS C93200
13a Weld fitting	1.4301	A 276 Grade 304
14 Union nut	CC493K	B 505 UNS C93200

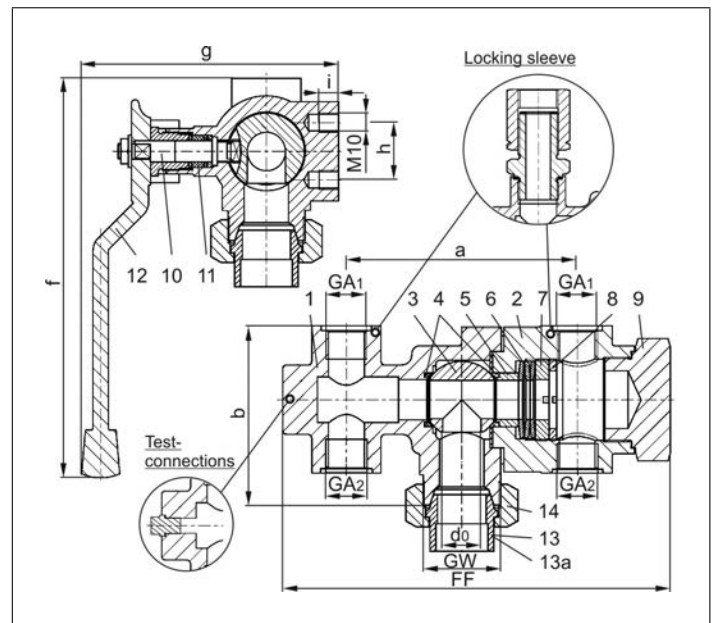

Type 06510 - Standard design	Technical data		
Nominal size	DN	20	20
Dimension code	.X.	2040	2060
Flow diameter	d ₀	20	20
Inlet	GW	M40x2	M40x2
Outlet	GA ₁	1/2	3/4
Outlet	GA ₂	1/2	1/2
Face-to-face dimension	FF	201	201
Length	a	120	120
Height	b	92	92
Length	f	208	208
Length	g	134	134
Length	h	30	30
Thread depth	i	10	10
Wrench size across flats	S ₁	50	50
Weight	ca. kg	5.1	5.0
Kvs - Value, one side open	m ³ /h	7.7	7.7
Cv - Value, one side open	gal /min	9.2	9.2

Dimensions in mm.

Edition 2016-01

Important:

The valves must be fixed at the provided threads M10.

Changeover Valves

Type 06510 - Divertor Valve



Cryogenic Divertor Valves, bronze, PN50
for the installation of two safety valves,
provided for bursting disc connections,
"cleaned and degreased for oxygen service"

Artikel-Nr. 06510.X.0120

Female thread connection (G) acc. to ISO 228/1

Artikel-Nr. 06510.X.6000

Female thread connection NPTF acc. to ANSI B 1.20.1

Available Options - on request only:

- Inlet with union type braze or butt weld fitting
- Two extra test connections 1/4" edgeways
- Outlet GA₁ with installed locking sleeve for easy positioning of safety valves
- Combination of different outlet threads GA₁ - GA₂
- **Safety lock (Part No. 55394.0049.0765)**

Applications:

Approved for air gases, vapours and cryogenic liquefied gases incl. LNG.
Working temperature: -196°C / -321°F (77K) up to +120°C / +248°F (393K)

Materials	DIN EN	ASTM
1 Body I	CC491K	B 62 UNS C83600
2 Body II	CC491K	B 62 UNS C83600
3 Ball	1.4571	A 276 Grade 316Ti
4 Seat rings	PCTFE	
5 Bush	CW614N	B 283 UNS C38500
6 Spring plates	1.4571	A 313 Grade 316Ti
7 Spring clamp	CW614N	B 283 UNS C38500
8 Thread ring	CW614N	B 283 UNS C38500
10 Stem	1.4301	A 276 Grade 304
11 Gland packing	Graphit / PTFE	
12 Lever	CC491K	B 62 UNS C83600

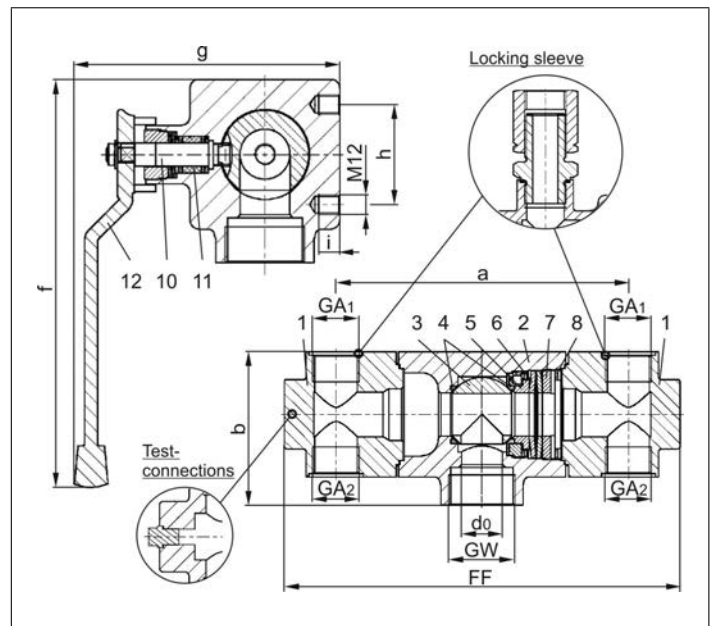
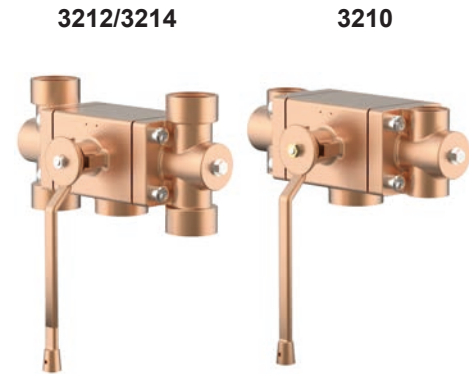

Standard marking acc. to Pressure Equipment Directive 97/23/EC (PED).



Type 06510 - Standard design	Technical data			
Nominal size	DN	32	32	32
Dimension code	.X.	3210	3212	3214
Flow diameter	d ₀	23	23	23
Inlet	GW	1-1/2	1-1/2	1-1/2
Outlet	GA ₁	1	1-1/4	1-1/2
Outlet	GA ₂	1	1-1/4	1-1/2
Face-to-face dimension	FF	300	284	284
Length	a	210	210	210
Height	b	110	145	145
Length	f	245	245	245
Length	g	160	160	160
Length	h	60	60	60
Thread depth	i	12.5	12.5	12.5
Weight	ca. kg	12.2	13.5	13.5
Kvs - Value, one side open	m ³ /h	16.7	16.7	16.7
Cv - Value, one side open	gal /min	19.4	19.4	19.4

Dimensions in mm.

Important:

The valves must be fixed at the provided threads M12.

Changeover Valves

Type 06512 - Divertor Valve



Cryogenic Divertor Valves, bronze, PN50
for the installation of four safety valves,
provided for bursting disc connections,
"cleaned and degreased for oxygen service"

Artikel-Nr. 06512.X.0000

Female thread connection (G) acc. to ISO 228/1

Artikel-Nr. 06512.X.6000

Female thread connection NPTF acc. to ANSI B 1.20.1

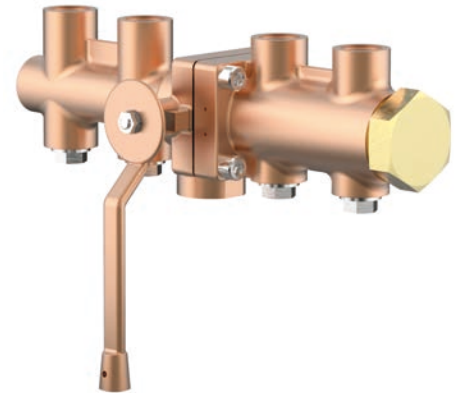

Available Options - on request only:

- Inlet with union type braze or butt weld fitting
- Two extra test connections 1/4" edgeways
- Inlet: female thread (GW) 1/2" or 3/4"
- Outlet GA₁ with installed locking sleeve for easy positioning of safety valves
- Combination of different outlet threads GA₁ - GA₂
- **Safety lock (Part No. 55394.0043.0765)**

Applications:

Approved for air gases, vapours and cryogenic liquefied gases incl. LNG.
Working temperature: -196°C / -321°F (77K) up to +120°C / +248°F (393K)

Materials	DIN EN	ASTM
1 Body I	CC491K	B 62 UNS C83600
2 Body II	CC491K	B 62 UNS C83600
3 Ball	1.4571	A 276 Grade 316Ti
4 Seat rings	PCTFE	
5 Bush	CW614N	B 283 UNS C38500
6 Spring plates	1.4571	A 313 Grade 316Ti
7 Spring clamp	CW614N	B 283 UNS C38500
8 Thread ring	CW614N	B 283 UNS C38500
9 Plug	CW614N	B 283 UNS C38500
10 Stem	1.4301	A 276 Grade 304
11 Gland packing	Graphit / PTFE	
12 Lever	CC491K	B 62 UNS C83600

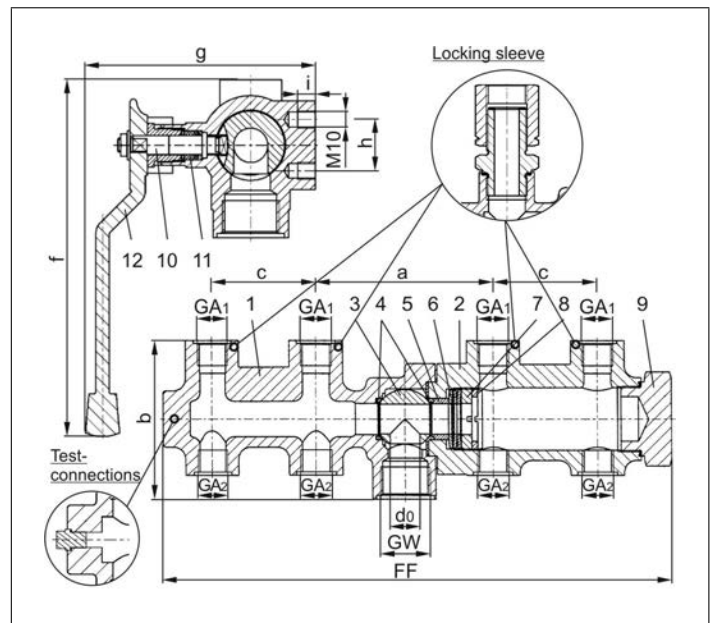

Type 06512 - Standard design	Technical data		
Nominal size	DN	20	20
Dimension code	.X.	2004	2006
Flow diameter	d ₀	20	20
Inlet	GW	1	1
Outlet	GA ₁	1/2	3/4
Outlet	GA ₂	1/2	1/2
Face-to-face dimension	FF	345	345
Length	a	120	120
Height	b	107	107
Length	c	70	70
Length	f	223	223
Length	g	134	134
Length	h	30	30
Thread depth	i	10	10
Weight	ca. kg	7.2	7.1
Kvs - Value, one side open	m ³ /h	7.7	7.7
Cv - Value, one side open	gal /min	9.2	9.2

Important:

The valves must be fixed at the provided threads M10.

Dimensions in mm.
Edition 2016-01



Changeover Valves

Type 06520 - Divertor Valve



Cryogenic Divertor Valves, stainless steel, inner parts made of brass, PN50
for the installation of two safety valves,
provided for bursting disc connections,
"cleaned and degreased for oxygen service"

Part No. 06520.X.0000

Female thread connection (G) acc. to ISO 228/1

Part No. 06520.X.6***

Female thread connection NPT acc. to ANSI B 1.20.1



Available Options - on request only:

- Two extra test connections 1/4" edgeways
- Inlet: female thread (GW) 3/4"
- Outlet GA₁ with installed locking sleeve for easy positioning of safety valves
- Combination of different outlet threads GA₁ - GA₂
- **Safety lock (Part No. 55394.0043.0765)**

Applications:

Approved for air gases, vapours and cryogenic liquefied gases incl. LNG.

Working temperature: -196°C / -321°F (77K) up to +120°C / +248°F (393K)

Materials	DIN EN	ASTM
1 Body I	1.4308	A 351 CF8
2 Body II	1.4308	A 351 CF8
3 Ball	1.4571	A 276 Grade 316Ti
4 Seat rings	PCTFE	
5 Bush	CW614N	B 283 UNS C38500
6 Spring plates	1.4571	A 313 Grade 316Ti
7 Spring clamp	CW614N	B 283 UNS C38500
8 Thread ring	CW614N	B 283 UNS C38500
9 Plug	1.4408	A 351 CF8M
10 Stem	1.4301	A 276 Grade 304
11 Gland packing	Graphite / PTFE	
12 Lever	1.4308	A 351 CF8

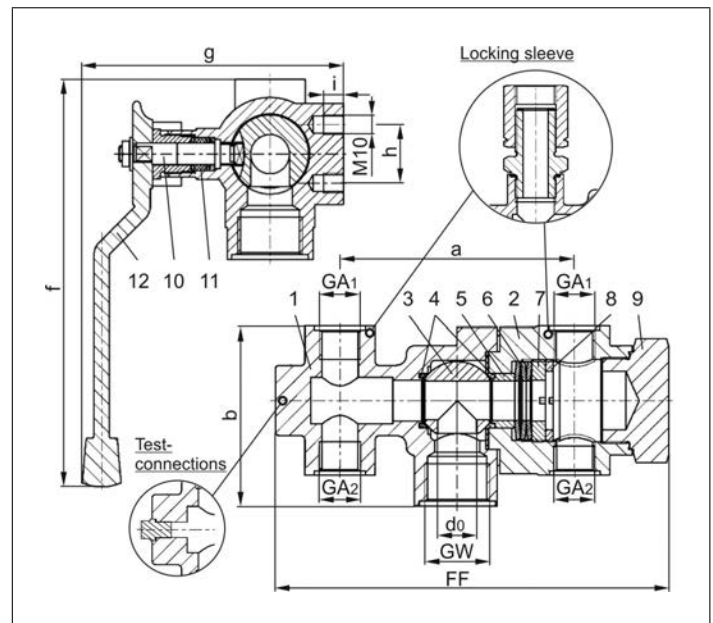

Type 06520 - Standard design	Technical Data		
Nominal Size	DN	20	20
Dimension code	.X.	2004	2006
Flow diameter	d ₀	20	20
Inlet	GW	1	1
Outlet	GA ₁	1/2	3/4
Outlet	GA ₂	1/2	1/2
Face-to-face dimension	FF	201	201
Length	a	120	120
Height	b	92	92
Length	f	208	208
Length	g	134	134
Length	h	30	30
Thread depth	i	10	10
Weight	ca. kg	4.8	4.7
Kvs - Value, one side open	m ³ /h	7.7	7.7
Cv - Value, one side open	gal /min	9.2	9.2

Dimensions in mm.

Important:

The valves must be fixed at the provided threads M10.

Changeover Valves

Type 06530 - Divertor Valve



Cryogenic Divertor Valves, stainless steel, PN50

for the installation of two safety valves,
provided for bursting disc connections,
"cleaned and degreased for oxygen service"

Part No. 06530.X.0000

Female thread connection (G) acc. to ISO 228/1

Part No. 06530.X.6***

Female thread connection NPT acc. to ANSI B 1.20.1



Available Options - on request only:

- Two extra test connections 1/4" edgeways
- Inlet: female thread (GW) 3/4"
- Outlet GA₁ with installed locking sleeve for easy positioning of safety valves
- Combination of different outlet threads GA₁ - GA₂
- **Safety lock (Part No. 55394.0043.0765)**

Applications:

Approved for air gases, vapours and cryogenic liquefied gases incl. LNG.

Working temperature: -196°C / -321°F (77K) up to +120°C / +248°F (393K)

Materials	DIN EN	ASTM
1 Body I	1.4308	A 351 CF8
2 Body II	1.4308	A 351 CF8
3 Ball	1.4571	A 276 Grade 316Ti
4 Seat rings	PCTFE	
5 Bush	1.4301	A 276 Grade 304
6 Spring plates	1.4571	A 313 Grade 316Ti
7 Spring clamp	1.4571	A 276 Grade 316Ti
8 Thread ring	1.4571	A 276 Grade 316Ti
9 Plug	1.4408	A 351 CF8M
10 Stem	1.4301	A 276 Grade 304
11 Gland packing	Graphite / PTFE	
12 Lever	1.4308	A 351 CF8

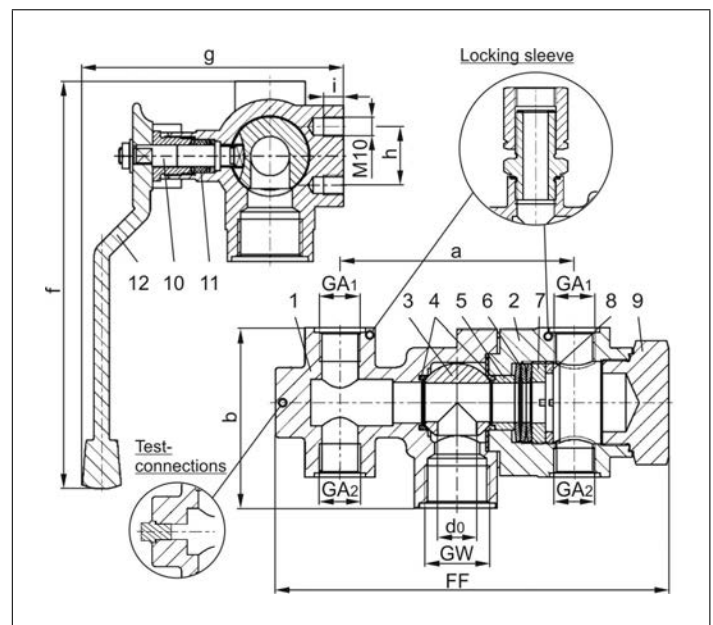

Type 06530 - Standard design	Technical Data		
Nominal Size	DN	20	20
Dimension code	.X.	2004	2006
Flow diameter	d ₀	20	20
Inlet	GW	1	1
Outlet	GA ₁	1/2	3/4
Outlet	GA ₂	1/2	1/2
Face-to-face dimension	FF	201	201
Length	a	120	120
Height	b	92	92
Length	f	208	208
Length	g	134	134
Length	h	30	30
Thread depth	i	10	10
Weight	ca. kg	4.8	4.7
Kvs - Value, one side open	m ³ /h	7.7	7.7
Cv - Value, one side open	gal /min	9.2	9.2

Dimensions in mm.

Edition 2016-01

Important:

The valves must be fixed at the provided threads M10.

Changeover Valves

Type 06405 - Changeover Valve



Cryogenic Changeover Valves, brass

for the installation of two safety valves,
with indicator and two test connections G 1/4,
"cleaned and degreased for oxygen service"

Part No. 06405.0150.0000, DN15, PN40, metal to metal seated
Female thread connection (G) acc. to ISO 228/1

Part No. 06405.0150.6000, DN15, PN40, metal to metal seated
Female thread connection NPTF acc. to ANSI B 1.20.1

Part No. 06405.0250.0000, DN25, PN45, PTFE valve seal
Female thread connection (G) acc. to ISO 228/1

Part No. 06405.0250.6000, DN25, PN45, PTFE valve seal
Female thread connection NPTF acc. to ANSI B 1.20.1

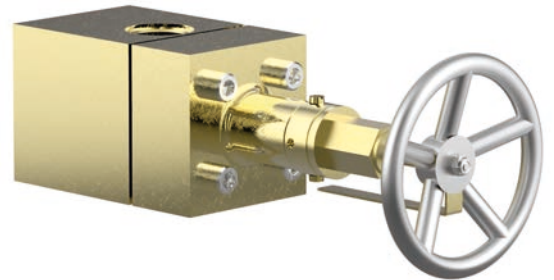

Available options - on request only:

- Valve with bursting disc connections
- Outlet: GA with installed locking sleeve for easy positioning of safety valves
- Outlet: GA with thread 3/4"

Applications:

Approved for air gases, vapours and cryogenic liquefied gases incl. LNG.
Working temperature: -196°C / -321°F (77K) up to +185°C / +365°F (458K)

Materials	DIN EN	ASTM
1 Body I	CW509L	B 111 UNS C28000
2 Body II	CW509L	B 111 UNS C28000
3 Disc	1.4301	A 276 Grade 304
4 Valve seal DN25	PTFE	
5 Stem	1.4301	A 276 Grade 304
6 Gland packing	Graphite / PTFE	
7 Top ring	CW614N	B 283 UNS C38500
8 Gland nut DN15	CW710R	no reference
8 Gland nut DN25	CW614N	B 283 UNS C38500
9 Handwheel	Aluminium alloy	

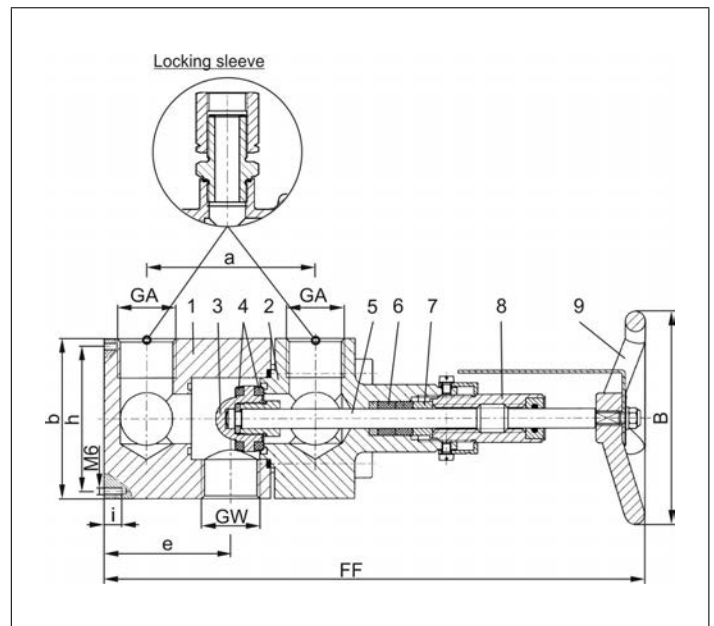

Type 06405 - Standard design	Technical data		
Nominal size	DN	15	25
Dimension code	.X.	0150	0250
Inlet	GW	3/4	1
Outlet	GA	1/2	1
Face-to-face dimension	FF	240	310
Length	a	80	96
Length	b	65	90
Length	e	50	72
Length	h	55	80
Thread depth	i	12	12
Handwheel-Ø	B	100	120
Weight	ca. kg	4.1	9.5
Kvs - Value, one side open	m ³ /h	6.0	14.0
Cv - Value, one side open	gal /min	6.9	16.1
Kvs - Value, central position	m ³ /h	13.0	25.0
Cv - Value, central position	gal /min	15.0	28.9

Dimensions in mm.

Important:

The valves must be fixed at the provided threads M6.

Changeover Valves

Type 06401 - Changeover Valve DN15



Cryogenic Changeover Valves, stainless steel, PN125

for the installation of two safety valves,
with two test connections G 1/4,
"cleaned and degreased for oxygen service"

Part No. 06401.0150.0000

In- and Outlet: locking sleeve G 3/4

Part No. 06401.0150.9***

*** Changeover valves with other threads for
vessel or safety valve connection on request

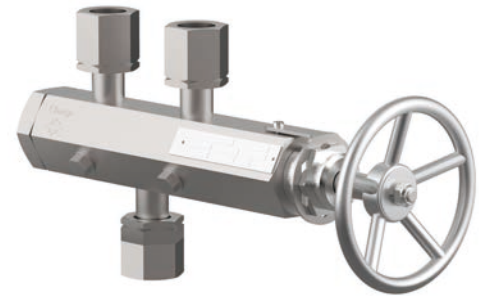

Available options - on request only:

- Changeover valves with pneumatic or electric actuator
- Inlet GW and/or outlet GA with female thread (G) acc. to ISO 228/1
- Inlet GW and/or outlet GA with female thread NPT acc. to ANSI B 1.20.1
- Combination of different thread connections GW - GA

Applications:

Approved for air gases, vapours and cryogenic liquefied gases incl. LNG.
Working temperature: -196°C / -321°F (77K) up to +185°C / +365°F (458K)

Materials	DIN EN	ASTM
1 Body	1.4571	A 276 Grade 316Ti
2 Plug	1.4571	A 276 Grade 316Ti
3 Disc stem	1.4571	A 276 Grade 316Ti
4 Valve seal	PTFE / Carbon filled (25%)	
5 Disc	1.4571	A 276 Grade 316Ti
6 Disc nut	1.4301/A2	A 194 B8
7 Gland packing	PTFE / Carbon filled (25%)	
8 Head piece	CW452K nickel plated	B 159 UNS C51900 nickel plated
9 Stem	1.4571	A 276 Grade 316Ti
10 Handwheel	Aluminium alloy	
11 Welding piece	1.4571	A 276 Grade 316Ti
12 Locking sleeve	1.4571	A 276 Grade 316Ti
13 Thread connection	1.4571	A 276 Grade 316Ti

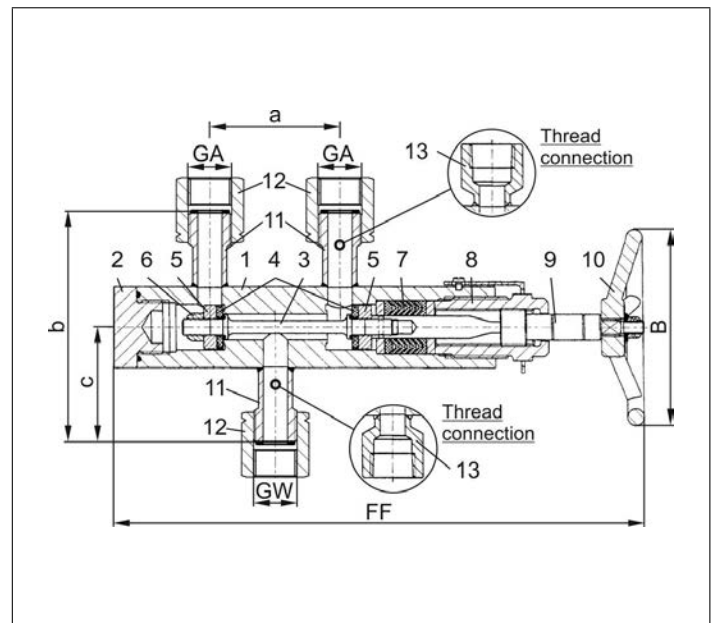

Typ 06401 - Standard design	Technical data	
Nominal size	DN	15
Inlet	GW	G 3/4 LH
Outlet	GA	G 3/4 LH
Face-to-face dimension	FF	325
Handwheel-Ø	B	120
Length	a	80
Height	b	140
Length	c	70
Weight	ca. kg	5.0
Kvs - Value, one side open	m ³ /h	4.0
Cv - Value, one side open	gal /min	4.6
Kvs - Value, central position	m ³ /h	5.8
Cv - Value, central position	gal /min	6.7

Dimensions in mm.



Changeover Valves

Type 06401 - Changeover Valve DN15



Cryogenic Changeover Valves, stainless steel, PN160

for the installation of two safety valves,
with two test connections G 1/4,
"cleaned and degreased for oxygen service"

Part No. 06401.0150.9029

Inlet: Flange, DN15, PN 160
Outlet: locking sleeve G 3/4

Part No. 06401.0150.9***

*** Changeover valves with other flanges for vessel connection
and threaded connection for safety valves on request

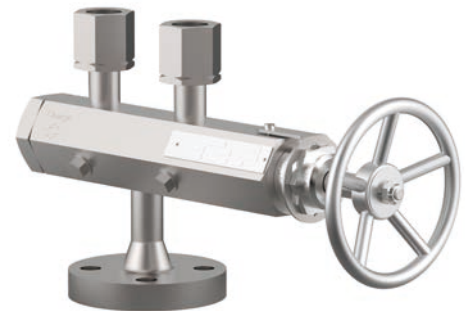

Available options - on request only:

- Changeover valves with pneumatic or electric actuator
- Outlet GA with female thread (G) acc. to ISO 228/1
- Outlet GA with female thread NPT acc. to ANSI B 1.20.1
- Outlet GA with flanged connections

Applications:

Approved for air gases, vapours and cryogenic liquefied gases incl. LNG.
Working temperature: -196°C / -321°F (77K) up to +185°C / +365°F (458K)

Materials	DIN EN	ASTM
1 Body	1.4571	A 276 Grade 316Ti
2 Plug	1.4571	A 276 Grade 316Ti
3 Disc stem	1.4571	A 276 Grade 316Ti
4 Valve seal	PTFE / Carbon filled (25%)	
5 Disc	1.4571	A 276 Grade 316Ti
6 Disc nut	1.4301/A2	A 194 B8
7 Gland packing	PTFE / Carbon filled (25%)	
8 Head piece	CW452K nickel plated	B 159 UNS C51900 nickel plated
9 Stem	1.4571	A 276 Grade 316Ti
10 Handwheel	Aluminium alloy	
11 Welding piece	1.4571	A 276 Grade 316Ti
12 Locking sleeve	1.4571	A 276 Grade 316Ti
13 Thread connection	1.4571	A 276 Grade 316Ti
14 Adapter	1.4571	A 276 Grade 316Ti
15 Flange	1.4571	A 276 Grade 316Ti

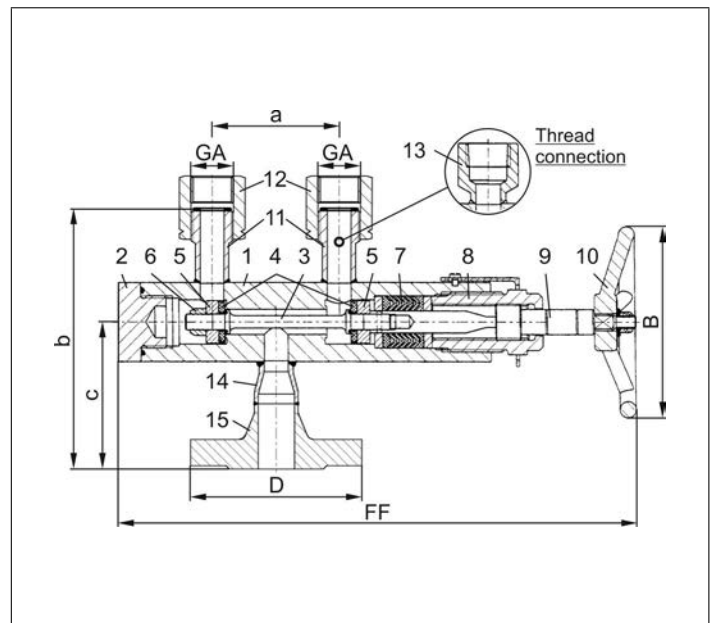

Type 06401 - Standard design	Technical data	
Nominal size	DN	15
Flange diameter	D	105
Outlet	GA	G 3/4 LH
Face-to-face dimension	FF	325
Handwheel-Ø	B	120
Length	a	80
Height	b	170
Length	c	100
Weight	ca. kg	6.0
Kvs - Value, one side open	m ³ /h	4.0
Cv - Value, one side open	gal /min	4.6
Kvs - Valve, central position	m ³ /h	5.8
Cv - Valve, central position	gal /min	6.7

Dimensions in mm.

Changeover Valves

Type 06401 - Changeover Valve DN25



Cryogenic Changeover Valves, stainless steel, PN125

for the installation of two safety valves,
with two test connections G 1/4,
"cleaned and degreased for oxygen service"

Part No. 06401.0250.9045

In- and Outlet: locking sleeve G 1

Part No. 06401.0250.9***

*** Changeover valves with other threads for
vessel or safety valve connection on request

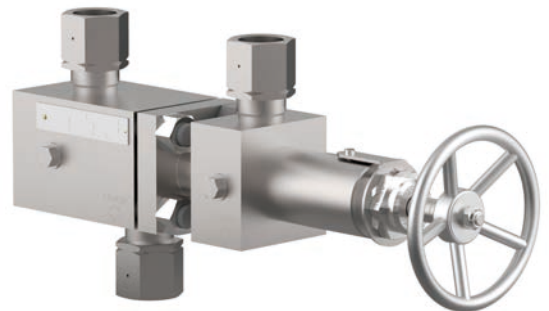

Available options - on request only:

- Changeover valves with pneumatic or electric actuator
- Inlet GW and/or outlet GA with female thread (G) acc. to ISO 228/1
- Inlet GW and/or outlet GA with female thread NPT acc. to ANSI B 1.20.1
- Combination of different thread connections GW - GA

Applications:

Approved for air gases, vapours and cryogenic liquefied gases incl. LNG.

Working temperature: -196°C / -321°F (77K) up to +185°C / +365°F (458K)

Materials	DIN EN	ASTM
1 Body	1.4571	A 276 Grade 316Ti
2 Plug	1.4571	A 276 Grade 316Ti
3 Disc stem	1.4571	A 276 Grade 316Ti
4 Valve seal	PCTFE	
5 Disc	1.4571	A 276 Grade 316Ti
6 Disc stem	1.4571	A 276 Grade 316Ti
7 Gland packing	PTFE / Carbon filled (25%)	
8 Head piece	CW452K nickel plated	B 159 UNS C51900 nickel plated
9 Stem	1.4571	A 276 Grade 316Ti
10 Handwheel	Aluminium alloy	
11 Welding piece	1.4571	A 276 Grade 316Ti
12 Locking sleeve	1.4571	A 276 Grade 316Ti
13 Thread connection	1.4571	A 276 Grade 316Ti

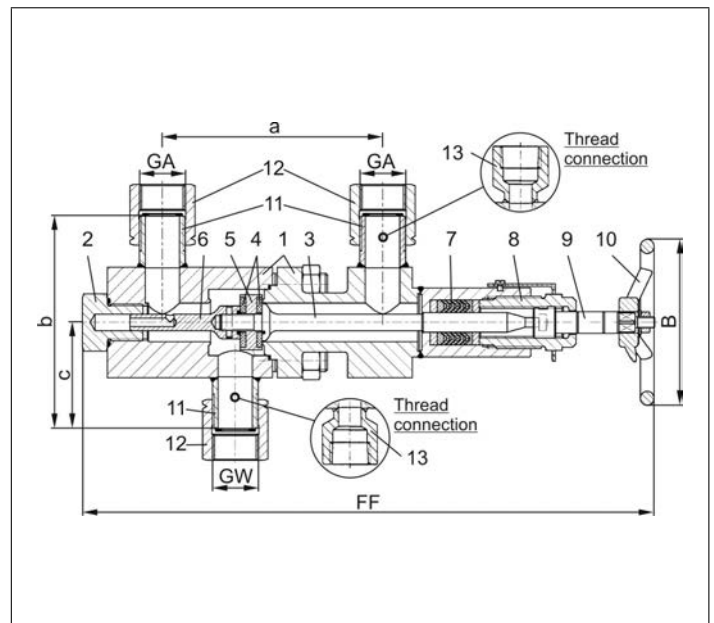

Typ 06401 - Standard design	Technical data	
Nominal size	DN	25
Inlet	GW	G 1 LH
Outlet	GA	G 1 LH
Face-to-face dimension	FF	415
Handwheel-Ø	B	120
Length	a	160
Height	b	160
Length	c	80
Weight	ca. kg	11.7
Kvs - Value, one side open	m ³ /h	13.0
Cv - Value, one side open	gal /min	15.0
Kvs - Value, central position	m ³ /h	15.5
Cv - Value, central position	gal /min	17.9

Dimensions in mm.



Changeover Valves

Type 06401 - Changeover Valve DN25



Cryogenic Changeover Valves, stainless steel, PN160

for the installation of two safety valves,
with two test connections G 1/4,
"cleaned and degreased for oxygen service"

Part No. 06401.0250.9018

Inlet Flange, DN 25, PN 160
Outlet: locking sleeve G1

Part No. 06401.0250.9***

*** Changeover valves with other flanges for vessel connection
and connection for safety valves on request

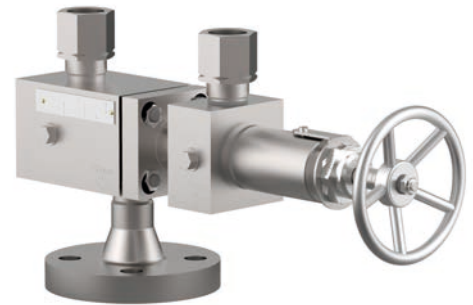

Available options - on request only:

- Changeover valves with pneumatic or electric actuator
- Outlet GA with female thread (G) acc. to ISO 228/1
- Outlet GA with female thread NPT acc. to ANSI B 1.20.1
- Outlet GA with flanged connections

Applications:

Approved for air gases, vapours and cryogenic liquefied gases incl. LNG.
Working temperature: -196°C / -321°F (77K) up to +185°C / +365°F (458K)

Materials	DIN EN	ASTM
1 Body	1.4571	A 276 Grade 316Ti
2 Plug	1.4571	A 276 Grade 316Ti
3 Disc stem	1.4571	A 276 Grade 316Ti
4 Valve seal	PCTFE	
5 Disc	1.4571	A 276 Grade 316Ti
6 Disc stem	1.4571	A 276 Grade 316Ti
7 Gland packing	PTFE / Carbon filled (25%)	
8 Head piece	CW452K nickel plated	B 159 UNS C51900 nickel plated
9 Stem	1.4571	A 276 Grade 316Ti
10 Handwheel	Aluminium alloy	
11 Welding piece	1.4571	A 276 Grade 316Ti
12 Locking sleeve	1.4571	A 276 Grade 316Ti
13 Thread connection	1.4571	A 276 Grade 316Ti
14 Adapter	1.4571	A 276 Grade 316Ti
15 Flange	1.4571	A 276 Grade 316Ti

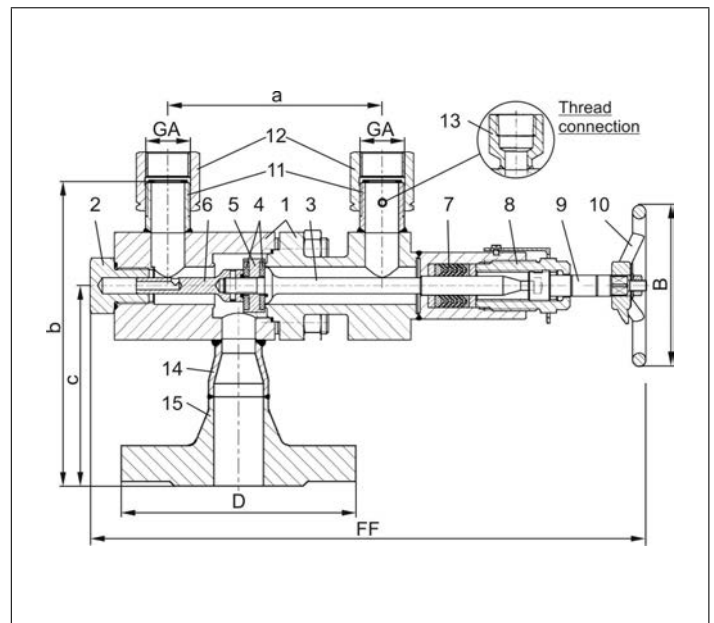

Type 06401 - Standard design	Technical data	
Nominal size	DN	25
Flange diameter	D	140
Outlet	GA	G 1 LH
Face-to-face dimension	FF	415
Handwheel-Ø	B	120
Length	a	160
Height	b	200
Length	c	125
Weight	ca. kg	14.1
Kvs - Value, one side open	m ³ /h	13.0
Cv - Value, one side open	gal /min	15.0
Kvs - Valve, central position	m ³ /h	15.5
Cv - Valve, central position	gal /min	17.9

Dimensions in mm.

Changeover Valves

Type 06401 - Bellow Sealed Changeover Valve



Cryogenic Bellow Sealed Changeover Valves, stainless steel, PN63

for the installation of two safety valves,
with indicator and two test connections G 1/4,
"cleaned and degreased for oxygen service"

Part No. 06401.0150.9***

*** In- and outlet connections with locking sleeve, female thread or flanges on request, working pressure up to PN100

Part No. 06401.0250.9***

*** In- and outlet connections with locking sleeve, female thread or flanges on request, working pressure up to PN63

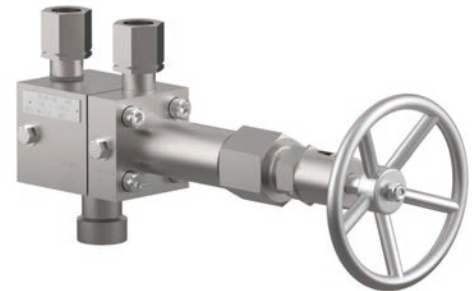

Available options - on request only:

- Changeover valves with pneumatic or electric actuator

Applications:

Approved for air gases, vapours and cryogenic liquefied gases incl. LNG.

Working temperature: -196°C / -321°F (77K) up to +185°C / +365°F (458K)

Materials	DIN EN	ASTM
1 Body I	1.4571	A 276 Grade 316Ti
2 Body II	1.4571	A 276 Grade 316Ti
3 Bellow stem	1.4571	A 276 Grade 316Ti
4 Valve seal	PCTEF	
5 Disc	1.4571	A 276 Grade 316Ti
6 Bellow	1.4571	A 276 Grade 316Ti
7 Upper part I	1.4571	A 276 Grade 316Ti
8 Upper part II	1.4571	A 276 Grade 316Ti
9 Stem	CW452K	B 159 UNS C51900
10 O-Rings	FPM (VITON)	
11 Top ring	1.4571	A 276 Grade 316Ti
12 Handwheel	Aluminium alloy	
13 Welding piece	1.4571	A 276 Grade 316Ti
14 Locking sleeve	1.4571	A 276 Grade 316Ti
15 Thread connection	1.4571	A 276 Grade 316Ti
16 Flange	1.4571	A 276 Grade 316Ti

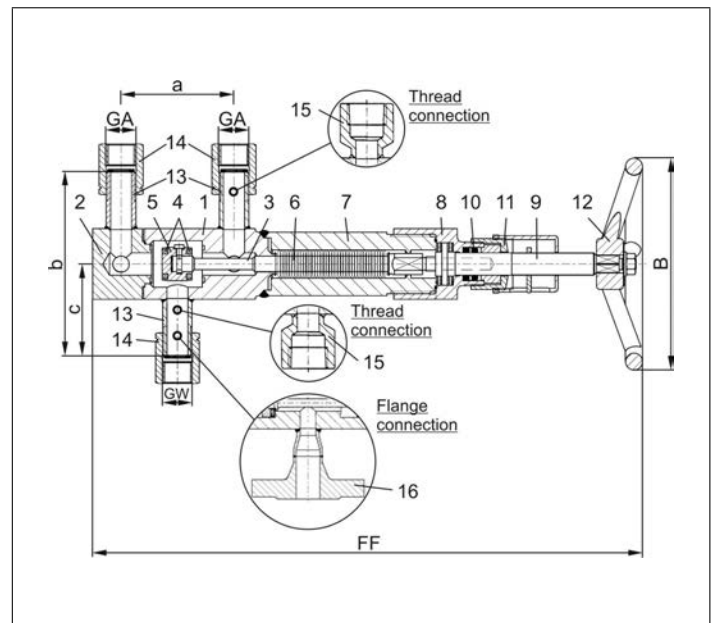

Typ 06401 - Standard design		Technical data	
Nominal size	DN	15	25
Dimension code	.X.	0150	0250
Inlet	GW	G 3/4 LH	G 1 LH
Outlet	GA	G 3/4 LH	G1 LH
Face-to-face dimension	FF	390	390
Handwheel-Ø	B	150	150
Length	a	80	80
Height	b	130	160
Length	c	65	80
Weight	ca. kg	8.0	9.9
Kvs - Value, one side open	m ³ /h	9.5	13.0
Cv - Value, one side open	gal /min	11.0	15.0
Kvs - Value, central position	m ³ /h	13.5	15.5
Cv - Value, central position	gal /min	15.6	17.9

Dimensions in mm.



Changeover Valves

Type 06900 - Bursting disc brass



for Cryogenic Divertor Valves

burst pressure range: 4,0 bar (58.0 psi) - 52,0 bar (754.0 psi)
 indicated burst pressure at burst temperature +20°C (68°F)
 burst pressure tolerance: ± 5 %
 "cleaned and degreased for oxygen service"

Part No. 06900.0400.00XX.XX

male thread G1/2 acc. to ISO 228/1

Part No. 06900.0400.50XX.XX

male thread 1/2" NPT acc. to ANSI B 1.20.1

XX.XX = Code for burst pressure

Example:

burst pressure **5,20** bar - 06900.0400.0005.20

burst pressure **24,00** bar - 06900.0400.0024.00

Calculation bar in psi: 1,0 bar = 14,503 psi (7,20 bar = 104,4 psi)

Available options - on request only:

- other thread sizes
- other burst pressures

Working temperature: -196°C (77K) up to +120°C (393K)



Materials	DIN EN	ASTM
1 Body	CW614N	B 283 UNS C38500
2 Burst disc	1.4401	AISI 316
3 Ring	CW614N	B 283 UNS C38500

Part No. (G-thread)	Standard-burst pressures
06900.0400.0005.20	5.2 bar / 75.4 psi
06900.0400.0007.20	7.2 bar / 104.4 psi
06900.0400.0014.00	14.0 bar / 203.0 psi
06900.0400.0016.50	16.5 bar / 239.3 psi
06900.0400.0020.20	20.2 bar / 292.9 psi
06900.0400.0024.00	24.0 bar / 348.0 psi
06900.0400.0025.08	25.08 bar / 363.7 psi
06900.0400.0027.00	27.0 bar / 391.5 psi
06900.0400.0046.00	46.0 bar / 667.0 psi

Part No. (NPT-thread)	Standard-burst pressures
06900.0400.5005.20	5.2 bar / 75.4 psi
06900.0400.5007.20	7.2 bar / 104.4 psi
06900.0400.5014.00	14.0 bar / 203.0 psi
06900.0400.5017.00	17.0 bar / 246.5 psi
06900.0400.5020.20	20.2 bar / 292.2 psi
06900.0400.5024.00	24.0 bar / 348.0 psi
06900.0400.5027.00	27.0 bar / 391.5 psi
06900.0400.5032.00	32.0 bar / 464.1 psi
06900.0400.5046.00	46.0 bar / 667.0 psi

Type 06900	Technical data	
Nominal size	GW	1/2
Height G-Thread	H	33,0
Height NPT-Thread	H	37,5
Length G-Thread	L	15,5
Length NPT-Thread	L	20,0
Orifice	d ₀	13,0
Wrench size across flats	S	30
Weight	ca. kg	0,1
Kvs-Value	m ³ /h	11,0
Cv-Value	gal/min	13,1

Dimensions in mm.

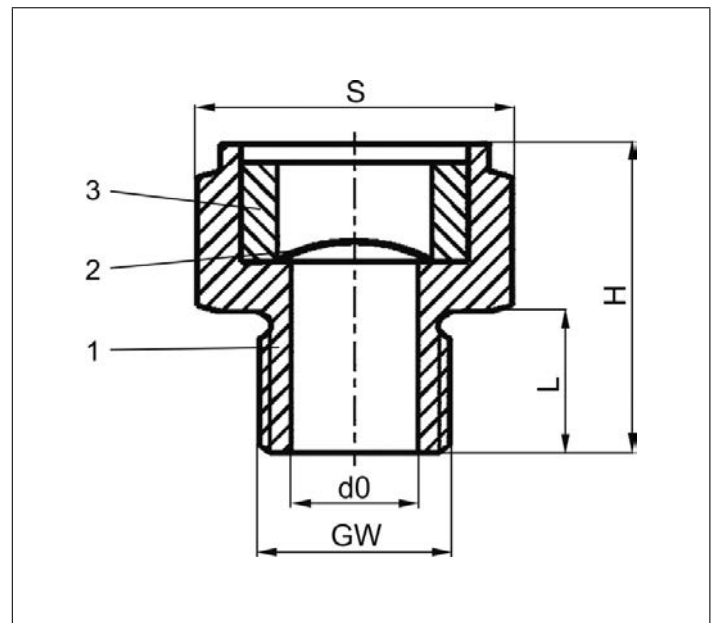

Changeover Valves

Type 06901 - Bursting disc stainless steel



for Cryogenic Divertor Valves

burst pressure range: 4,0 bar (58.0 psi) - 52,0 bar (754.0 psi)

indicated burst pressure at burst temperature +20°C (68°F)

burst pressure tolerance: ± 10 %

"cleaned and degreased for oxygen service"

Part No. 06901.0400.00XX.XX

male thread G1/2 acc. to ISO 228/1

Part No. 06901.0400.50XX.XX

male thread 1/2" NPT acc. to ANSI B 1.20.1

XX.XX = Code for burst pressure

Example:

burst pressure **5,20** bar - 06901.0400.000**5.20**

burst pressure **46,00** bar - 06901.0400.00**46.00**

Calculation bar in psi: 1,0 bar = 14,503 psi (40,00 bar = 580,1 psi)

Available options - on request only:

- other thread sizes
- other burst pressures

Working temperature: -196°C (77K) up to +120°C (393K)



Materials	DIN EN	ASTM
1 Body	1.4404	A 276 Grade 316L
2 Burst disc	Nickel	Nickel
3 Ring	1.4404	A 276 Grade 316L

Part No. (G-thread)	Standard-burst pressures
06901.0400.0005.20	5.2 bar / 75.4 psi
06901.0400.0007.00	7.0 bar / 101.5 psi
06901.0400.0008.10	8.1 bar / 117.4 psi
06901.0400.0010.00	10.0 bar / 145.0 psi
06901.0400.0015.00	15.0 bar / 217.5 psi
06901.0400.0018.00	18.0 bar / 261.0 psi
06901.0400.0020.20	20.2 bar / 292.9 psi
06901.0400.0020.57	20.57 bar / 298.34 psi
06901.0400.0022.00	22.0 bar / 319.0 psi
06901.0400.0024.00	24.0 bar / 348.0 psi
06901.0400.0027.00	27.0 bar / 391.5 psi
06901.0400.0043.56	43.56 bar / 631.78 psi

Part No. (NPT-thread)	Standard-burst pressures
06901.0400.5027.00	27.0 bar / 391.5 psi

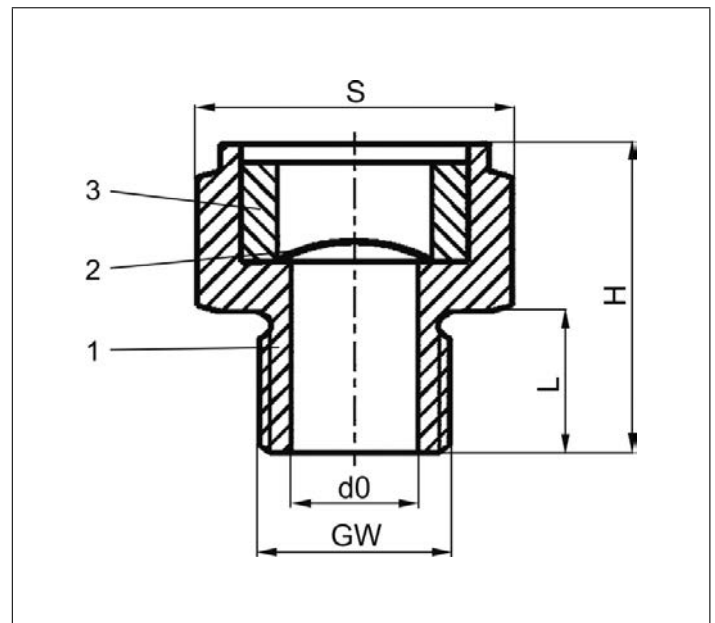

Type 06901	Technical data	
Nominal size	GW	1/2
Height G-Thread	H	34,0
Height NPT-Thread	H	38,5
Length G-Thread	L	15,5
Length NPT-Thread	L	20,0
Orifice	d ₀	13,0
Wrench size a/f up to 8,0 bar	S	46
Wrench size a/f from 8,01 bar	S	30
Weight	ca. kg	0,1
Kvs-Value	m ³ /h	11,0
Cv-Value	gal/min	13,1

Dimensions in mm.

Firesafe and Offshore Applications



Offshore and LNG: The MS Stavangerfjord of the shipping company Fjord Line ferry runs between Norway and Denmark fuelled 100% with the environmentally friendly LNG. Equipped with HEROSE valves specifically for LNG use.

Fire Safe Valves

Type 01651 - Globe Valve



Cryogenic-Globe and Globe/Check Valves, PN50 (DN100=PN40)

“Fire safe” type test approval acc. to EN ISO 10497

Stainless steel body and topwork, “live loaded” gland packing
“cleaned and degreased for oxygen service”

Part No. 01651.X.000*

Part No. 01651.X.500* Globe/Check Valve

* Butt weld connection for stainless steel pipes acc. to ISO 1127 or ASTM A312

Part No. 01651.X.0004

Part No. 01651.X.5004 Globe/Check Valve

Socket weld connection for stainless steel pipes acc. to ISO 1127 or ASTM A312

Available options - on request only:

- Welded stainless steel stubs acc. to ISO 1127 or ASTM A312 - length FF + 200mm
- Valve with control disc (tapered design)



Applications:

Approved for air gases, vapours and cryogenic liquefied gases incl. LNG.

Working temperature: -196°C / -321°F (77K) up to +120°C / +248°F (393K)

Recommended working temperature: -60°C / -76°F (213K) up to +120°C / +248°F (393K)

Materials	DIN EN	ASTM
1 Body	1.4308	A 351 CF8
2 Valve seal	PTFE / Carbon filled (25%)	
3 Disc	1.4301	A 276 Grade 304
4 Bonnet gasket	Graphite	
5 Headpiece	1.4301 / 1.4308	A 276 Grade 304 / A 351 CF8
6 Bolts	1.4301/A2	A 194 B8
8 Stem	1.4301	A 276 Grade 304
9 Gland packing	Graphite / PTFE / MICA	
10 Gland nut	1.4305	A 276 Grade 303
11 Handwheel	1.4409	SA 351 CF3M
12 Spring	1.4310	A 313 Grade 301
13 Bush	CW452K	B 159 UNS C51900

Standard marking acc. to Pressure Equipment Directive 97/23/EC (PED).

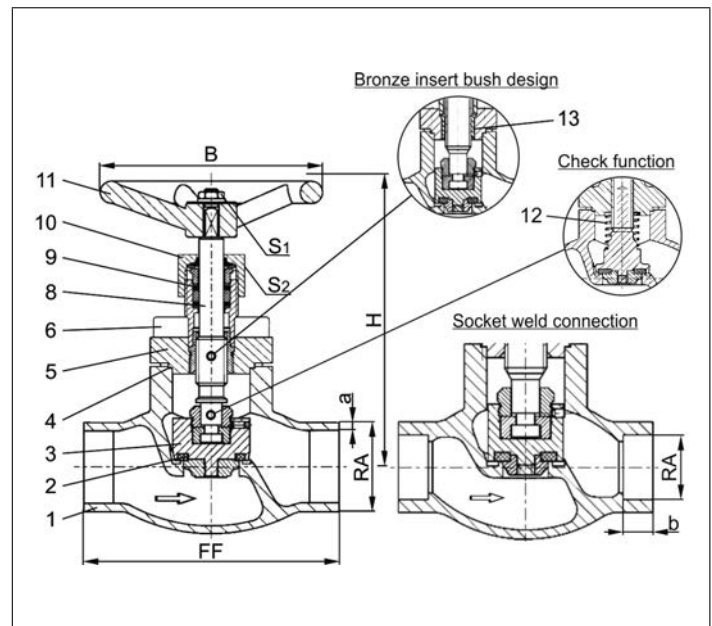

Type 01651 - Standard design	Technical data													
	DN	10	15	15	20	25	32	40	40	50	65	80	100	
Nominal size	DN	10	15	15	20	25	32	40	40	50	65	80	100	
Dimension code	.X.	1012	1517	1521	2026	2533	3238	4042	4048	5060	657x	8088	0114	
Face-to-face dimension	FF	70	85	85	100	115	115	130	130	155	205	245	280	
Height	H	140	140	140	140	140	170	175	175	200	260	310	350	
Outside pipe-Ø ISO 1127	RA	12.0	17.2	21.3	26.9	33.7	38.0	42.4	48.3	60.3	76.1	88.9	114.3	
Wall thickness pipe ISO 1127	a	1.0	1.6	2.0	2.0	2.0	2.0	2.0	2.0	2.0	2.6	3.2	6.0	
Outside pipe-Ø ASTM A312	RA	13.72	17.15	21.34	26.67	33.40	-	42.16	48.26	60.33	73.03	88.90	114.3	
Wall thickness pipe ASTM A312	a	dimensions acc. to S10 or S40												
Socket depth	b	6	10	10	13	13	-	13	13	16	16	16	20	
Handwheel-Ø	B	100	100	100	100	100	125	125	125	125	200	250	315	
Wrench size across flats	S ₁	10	10	10	10	10	13	13	13	13	13	13	13	
Wrench size across flats	S ₂	30	30	30	30	30	36	36	36	36	36	36	41	
Weight	ca. kg	1.0	1.25	1.3	1.7	2.0	2.8	4.2	4.2	6.7	10.7	16.0	23.0	
Kvs-Value	m ³ /h	1.6	3.8	4.3	6.7	11.5	14.0	20.6	22.6	37.1	71.1	104.0	170.0	
Cv-Value	gal/min	1.9	4.4	5.0	7.8	13.4	16.2	23.9	26.3	43.2	82.7	120.9	195.2	

Dimensions in mm.

Fire Safe Valves

Type 01655 - Globe Valve



Cryogenic-Globe and Globe/Check Valves, PN50
"Fire safe" type test approval acc. to EN ISO 10497

Stainless steel body and topwork,
 "live loaded" gland packing
 "cleaned and degreased for oxygen service"

Part No. 01655.X.0001

Part No. 01655.X.5001 Globe/Check Valve

Female thread connection (G) acc. to ISO 228/1

Part No. 01655.X.0006

Part No. 01655.X.5006 Globe/Check Valve

Female thread connection NPT acc. to ANSI B 1.20.1

Available options - on request only:

- Female thread connection (R) acc. to ISO 7-Rc
- Valve with control disc (tapered design)



Applications:

Approved for air gases, vapours and cryogenic liquefied gases incl. LNG.

Working temperature: -196°C / -321°F (77K) up to +120°C / +248°F (393K)

Recommended working temperature: -60°C / -76°F (213K) up to +120°C / +248°F (393K)

Materials	DIN EN	ASTM
1 Body	1.4308	A 351 CF8
2 Valve seal	PTFE / Carbon filled (25%)	
3 Disc	1.4301	A 276 Grade 304
4 Bonnet gasket	Graphite	
5 Headpiece	1.4301 / 1.4308	A 276 Grade 304 / A 351 CF8
6 Bolts	1.4301/A2	A 194 B8
8 Stem	1.4301	A 276 Grade 304
9 Gland packing	Graphite / PTFE / MICA	
10 Gland nut	1.4305	A 276 Grade 303
11 Handwheel	1.4409	SA 351 CF3M
12 Spring	1.4310	A 313 Grade 301
13 Bush	CW452K	B 159 UNS C51900

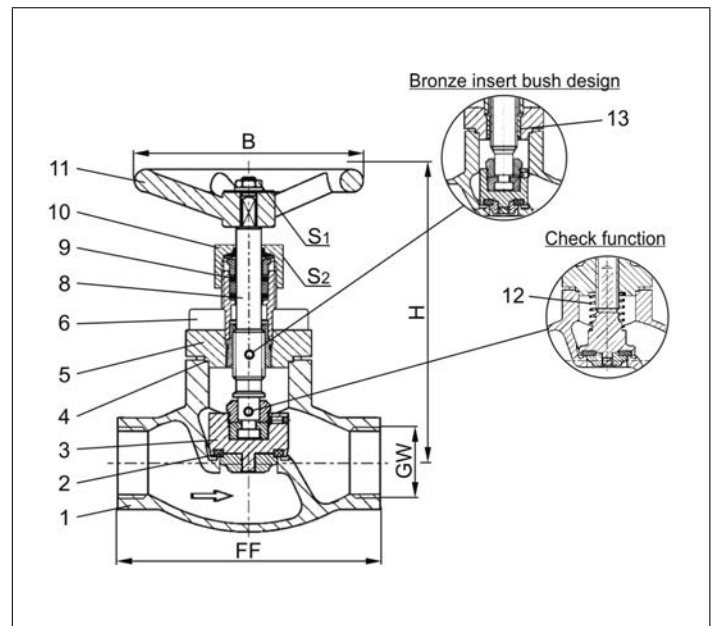

Standard marking acc. to Pressure Equipment Directive 97/23/EC (PED).



Type 01655 - Standard design	Technical data								
Nominal size	DN	10	10	15	20	25	40	40	50
Thread size	GW	1/4	3/8	1/2	3/4	1	1-1/4	1-1/2	2
Dimension code	.X.	0200	0300	0400	0600	1000	1200	1400	2000
Face-to-face dimension	FF	70	70	85	100	115	130	130	155
Height	H	140	140	140	140	140	175	175	200
Handwheel-Ø	B	100	100	100	100	100	125	125	125
Wrench size across flats	S ₁	10	10	10	10	10	13	13	13
Wrench size across flats	S ₂	30	30	30	30	30	36	36	36
Weight	ca. kg	1.0	1.0	1.3	1.7	2.0	4.2	4.2	6.7
Kvs-Value	m ³ /h	1.6	2.2	4.3	6.7	11.5	20.6	22.6	37.1
Cv-Value	gal/min	1.9	2.6	5.0	7.8	13.4	23.9	26.3	43.2

Dimensions in mm.



Fire Safe Valves

Type 03651 - Globe Valve



Cryogenic-Globe and Globe/Check Valves, PN40
"Fire safe" type test approval acc. to EN ISO 10497

Stainless steel body and topwork,
 "live loaded" gland packing
 "cleaned and degreased for oxygen service"

Part No. 03651.X.0002

Part No. 03651.X.5002 Globe/Check Valve

Flanged connection acc. to DIN EN 1092-1 PN40

Available options - on request only:

- Valve with control disc (tapered design)
- Nominal sizes DN15, DN20 and DN150 with welded flange



Applications:

Approved for air gases, vapours and cryogenic liquefied gases incl. LNG.

Working temperature: -196°C / -321°F (77K) up to +120°C / +248°F (393K)

Recommended working temperature: -60°C / -76°F (213K) up to +120°C / +248°F (393K)

Materials	DIN EN	ASTM
1 Body	1.4308	A 351 CF8
2 Valve seal	PTFE / Carbon filled (25%)	
3 Disc	1.4301	A 276 Grade 304
4 Bonnet gasket	Graphite	
5 Headpiece	1.4301 / 1.4308	A 276 Grade 304 / A 351 CF8
6 Bolts	1.4301/A2	A 194 B8
8 Stem	1.4301	A 276 Grade 304
9 Gland packing	Graphite / PTFE / MICA	
10 Gland nut	1.4305	A 276 Grade 303
11 Handwheel	1.4409	SA 351 CF3M
12 Spring	1.4310	A 313 Grade 301
13 Bush	CW452K	B 159 UNS C51900

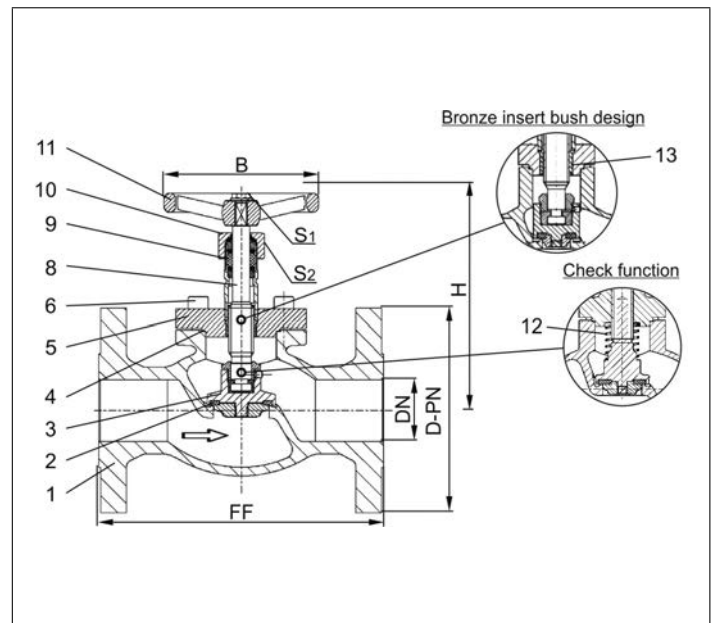

Standard marking acc. to Pressure Equipment Directive 97/23/EC (PED).



Type 03651 - Standard design	Technical data						
Nominal size	DN	25	40	50	65	80	100
Dimension code - Flange EN 1092-1 PN40	.X.	0250	0400	0500	0650	0800	1000
Flange-Ø	D-PN	115	150	165	185	200	235
Face-to-face dimension	FF	160	200	230	290	310	350
Height	H	140	170	200	260	310	350
Handwheel-Ø	B	100	125	125	200	250	315
Wrench size across flats	S ₁	10	13	13	13	13	13
Wrench size across flats	S ₂	30	36	36	36	36	41
Weight	ca. kg	4.5	9.1	12.9	20.6	27.6	42.0
Kvs-Value	m ³ /h	11.5	22.6	37.1	71.1	104.0	170.0
Cv-Value	gal/min	13.4	26.3	43.2	82.7	120.9	195.2

Dimensions in mm.

Fire Safe Valves

Type 03651 - Globe Valve



Cryogenic-Globe and Globe/Check Valves, class 300
"Fire safe" type test approval acc. to EN ISO 10497

Stainless steel body and topwork,
 "live loaded" gland packing
 "cleaned and degreased for oxygen service"

Part No. 03651.X.0003

Part No. 03651.X.5003 Globe/Check Valve

Flanged connection acc. to ANSI B16.5 class 300

Available options - on request only:

- Valve with control disc (tapered design)
- Nominal sizes DN15, DN20 and DN150 with welded flange



Applications:

Approved for air gases, vapours and cryogenic liquefied gases incl. LNG.

Working temperature: -196°C / -321°F (77K) up to +120°C / +248°F (393K)

Recommended working temperature: -60°C / -76°F (213K) up to +120°C / +248°F (393K)

Materials	DIN EN	ASTM
1 Body	1.4308	A 351 CF8
2 Valve seal	PTFE / Carbon filled (25%)	
3 Disc	1.4301	A 276 Grade 304
4 Bonnet gasket	Graphite	
5 Headpiece	1.4301 / 1.4308	A 276 Grade 304 / A 351 CF8
6 Bolts	1.4301/A2	A 194 B8
8 Stem	1.4301	A 276 Grade 304
9 Gland packing	Graphite / PTFE / MICA	
10 Gland nut	1.4305	A 276 Grade 303
11 Handwheel	1.4409	SA 351 CF3M
12 Spring	1.4310	A 313 Grade 301
13 Bush	CW452K	B 159 UNS C51900

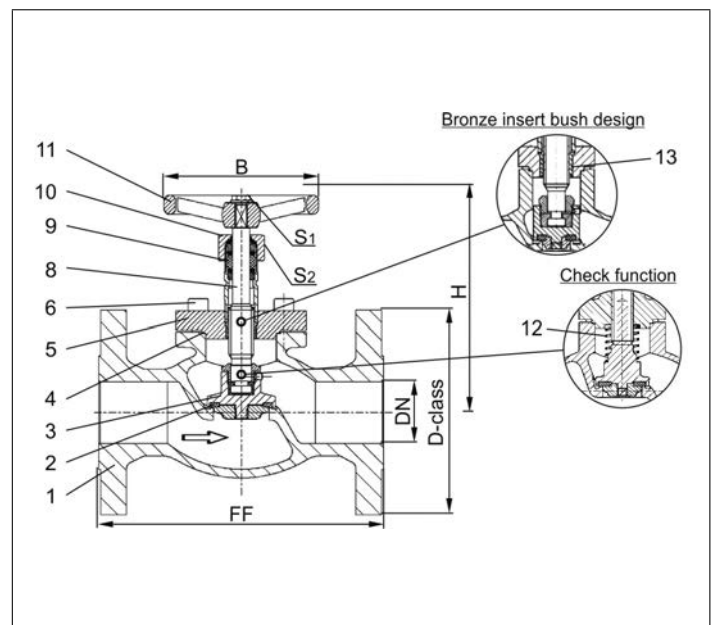

Standard marking acc. to Pressure Equipment Directive 97/23/EC (PED).



Type 03651 - Standard design	Technical data						
	DN	25	40	50	65	80	100
Nominal size	.X.	1000	1400	2000	2400	3000	4000
Dimension code - Flange ANSI B16.5 class 300	D-class	123.9	155.4	165	190.5	209.5	254
Flange-Ø	FF	160	200	230	290	310	350
Face-to-face dimension	H	140	170	200	260	310	350
Height	B	100	125	125	200	250	315
Handwheel-Ø	S ₁	10	13	13	13	13	13
Wrench size across flats	S ₂	30	36	36	36	36	41
Wrench size across flats	ca. kg	4.5	9.1	12.9	20.6	27.6	42.0
Weight	m ³ /h	11.5	22.6	37.1	71.1	104.0	170.0
Kvs-Value	gal/min	13.4	26.3	43.2	82.7	120.9	195.2
Cv-Value							

Dimensions in mm.



Fire Safe Valves

Type 01641 - Globe Valve



Cryogenic-Globe and Globe/Check Valves, PN50 (DN100/150=PN40)

“Fire safe” type test approval acc. to EN ISO 10497

Stainless steel body and topwork, “live loaded” gland packing
“cleaned and degreased for oxygen service”

Part No. 01641.X.001* (H = 270mm)

Part No. 01641.X.002* (H = 370mm)

Part No. 01641.X.501* (H = 270mm) Globe/Check Valve

Part No. 01641.X.502* (H = 370mm) Globe/Check Valve

* Butt weld connection for stainless steel pipes acc. to ISO 1127 or ASTM A312

Part No. 01641.X.0014 (H = 270mm)

Part No. 01641.X.0024 (H = 370mm)

Part No. 01641.X.5014 (H = 270mm) Globe/Check Valve

Part No. 01641.X.5024 (H = 370mm) Globe/Check Valve

Socket weld connection for stainless steel pipes acc. to ISO 1127 or ASTM A312

Available options - on request only:

- Welded stainless steel stubs acc. to ISO 1127 or ASTM A312 - length FF + 200mm
- Extension H up to 900mm
- Valve with control disc (tapered design)

Applications:

Approved for air gases, vapours and cryogenic liquefied gases incl. LNG.

Working temperature: -196°C / -321°F (77K) up to +120°C / +248°F (393K)



Materials	DIN EN	ASTM
1 Body	1.4308	A 351 CF8
2 Valve seal	PTFE / Carbon filled (25%)	
3 Disc	1.4301	A 276 Grade 304
4 Bonnet gasket	Graphite	
5 Headpiece	1.4301 / 1.4308	A 276 Grade 304 / A 351 CF8
6 Bolts	1.4301/A2	A 194 B8
7 Elongation tube	1.4541	A 213 TP 321
8 Stem	1.4301	A 276 Grade 304
9 Gland packing	Graphite / PTFE / MICA	
10 Gland nut	1.4305	A 276 Grade 303
11 Handwheel	1.4409	SA 351 CF3M
12 Spring	1.4310	A 313 Grade 301
13 Bush	CW452K	B 159 UNS C51900

Standard marking acc. to Pressure Equipment Directive 97/23/EC (PED).

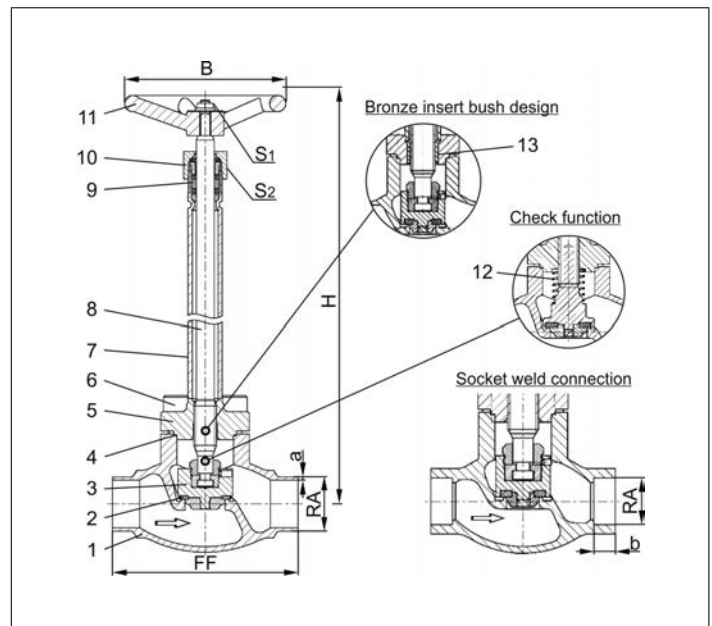

Type 01641	Technical data														
		DN	10	15	15	20	25	32	40	40	50	65	80	100	150
Nominal size	DN	10	15	15	20	25	32	40	40	50	65	80	100	150	
Dimension code	.X.	1012	1517	1521	2026	2533	3238	4042	4048	5060	657x	8088	0114	0168	
Face-to-face dimension	FF	70	85	85	100	115	115	130	130	155	205	245	280	400	
Height	H	270 mm or 370 mm												400	460
Outside pipe-Ø ISO 1127	RA	12.0	17.2	21.3	26.9	33.7	-	42.4	48.3	60.3	76.1	88.9	114.3	168.3	
Wall thickness pipe ISO 1127	a	1.0	1.6	2.0	2.0	2.0	-	2.0	2.0	2.0	2.6	3.2	6.0	7.11	
Outside pipe-Ø ASTM A312	RA	13.72	17.15	21.34	26.67	33.40	-	42.16	48.26	60.33	73.03	88.90	114.3	168.3	
Wall thickness pipe ASTM A312	a	dimensions acc. to S10 or S40													
Socket depth	b	6	10	10	13	13	-	13	13	16	16	16	20	20	
Handwheel-Ø	B	100	100	100	100	100	-	125	125	125	200	250	315	360	
Wrench size across flats	S ₁	10	10	10	10	10	-	13	13	13	13	13	13	19	
Wrench size across flats	S ₂	30	30	30	30	30	-	36	36	36	36	36	41	41	
Weight	ca. kg	1.4	1.65	1.7	2.1	2.4	-	4.7	4.7	7.2	12.7	17.0	24.5	54.0	
Kvs-Value	m ³ /h	1.6	3.8	4.3	6.7	11.5	14.0	20.6	22.6	37.1	71.1	104.0	170.0	350.0	
Cv-Value	gal/min	1.9	4.4	5.0	7.8	13.4	16.2	23.9	26.3	43.2	82.7	120.9	195.2	401.8	

Dimensions in mm. Compliance of tightness requirements acc. to EN 1626 for DN150 up to 20 bar differential pressure. In the range of >20-40 bar, 350-700ml (1 bar, 20°C [68°F]) are reached.

Fire Safe Valves

Type 01641 - Globe Valve



Cryogenic Globe Valves, DN200, PN25

"Fire safe" type test approval acc. to EN ISO 10497

Stainless steel body and topwork
"live loaded" gland packing

Part No. 01641.0219.001* (H=560)

Part No. 01641.0219.006* (H=1000)

*Butt weld connection for stainless steel pipes acc. to ISO 1127 or ASTM A312

Artikel-Nr. 01641.0219.00*4

Socket weld connection for stainless steel pipes acc. to ISO 1127 or ASTM A312

In flow direction, the valve with the nominal size DN200 is conform to tightness class L1 up to 9 bar maximum differential pressure acc. to DIN 12567 for LNG use. This standard can also be used for the tightness class of other cryogenic gases.

Available options - on request only

Applications:

Approved for air gases, vapours and cryogenic liquefied gases incl. LNG.

Working temperature: -196°C / -321°F (77K) up to +120°C / +248°F (393K)



Materials	DIN EN	ASTM
1 Body	1.4308	A 351 CF8
2 Valve seal	PTFE / Carbon filled (25%)	
3 Disc	1.4301	A 276 Grade 304
4 Bonnet gasket	Graphite	
5 Headpiece	1.4301	A 276 Grade 304
6 Bolts	1.4301/A2	A 194 B8
7 Elongation tube	1.4541	A 213 TP 321
8 Stem	1.4301	A 276 Grade 304
9 Gland packing	Graphite / PTFE / MICA	
10 Gland nut	1.4305	A 276 Grade 303
11 Handwheel	1.4571	A 313 Grade 316Ti
13 Bush	CW452K	B 159 UNS C51900

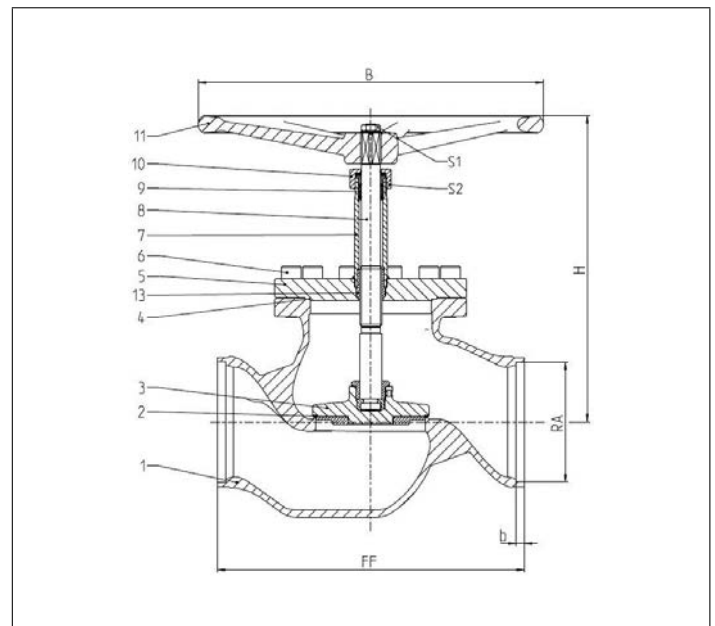

Standard marking acc. to Pressure Equipment Directive 97/23/EC (PED).



Type 01641 - Standard	Technical data	
Nominal size	DN	200
Dimension code	.X.	0219
Face-to-face dimension	FF	560
Height	H	1000
Outside pipe-Ø ISO 1127	RA	219.1
Wall thickness pipe ISO 1127	a	6.3
Outside pipe-Ø ASTM A312	RA	219.1
Wall thickness pipe ASTM A312	a	dimensions acc. to S10 or S40
Socket depth	b	15
Handwheel-Ø	B	630
Wrench size across flats	S ₁	30
Wrench size across flats	S ₂	65
Weight	ca. kg	135
Kvs-Value	m ³ /h	680
Cv-Value	gal/min	786

Dimensions in mm.



Fire Safe Valves

Type 01645 - Globe Valve



Cryogenic-Globe and Globe/Check Valves, PN50
 "Fire safe" type test approval acc. to EN ISO 10497

Stainless steel body and topwork, "live loaded" gland packing
 "cleaned and degreased for oxygen service"

Part No. 01645.X.0011 (H = 270mm)
Part No. 01645.X.0021 (H = 370mm)
Part No. 01645.X.5011 (H = 270mm) Globe/Check Valve
Part No. 01645.X.5021 (H = 370mm) Globe/Check Valve
 Female thread connection (G) acc. to ISO 228/1

Part No. 01645.X.0016 (H = 270mm)
Part No. 01645.X.0026 (H = 370mm)
Part No. 01645.X.5016 (H = 270mm) Globe/Check Valve
Part No. 01645.X.5026 (H = 370mm) Globe/Check Valve
 Female thread connection NPT acc. to ANSI B 1.20.1

Available options - on request only:

- Female thread connection (R) acc. to ISO 7-Rc
- Extension H up to 900mm
- Valve with control disc (tapered design)

Applications:

Approved for air gases, vapours and cryogenic liquefied gases incl. LNG.
 Working temperature: -196°C / -321°F (77K) up to +120°C / +248°F (393K)



Materials	DIN EN	ASTM
1 Body	1.4308	A 351 CF8
2 Valve seal	PTFE / Carbon filled (25%)	
3 Disc	1.4301	A 276 Grade 304
4 Bonnet gasket	Graphite	
5 Headpiece	1.4301 / 1.4308	A 276 Grade 304 / A 351 CF8
6 Bolts	1.4301/A2	A 194 B8
7 Elongation tube	1.4541	A 213 TP 321
8 Stem	1.4301	A 276 Grade 304
9 Gland packing	Graphite / PTFE / MICA	
10 Gland nut	1.4305	A 276 Grade 303
11 Handwheel	1.4409	SA 351 CF3M
12 Spring	1.4310	A 313 Grade 301
13 Bush	CW452K	B 159 UNS C51900

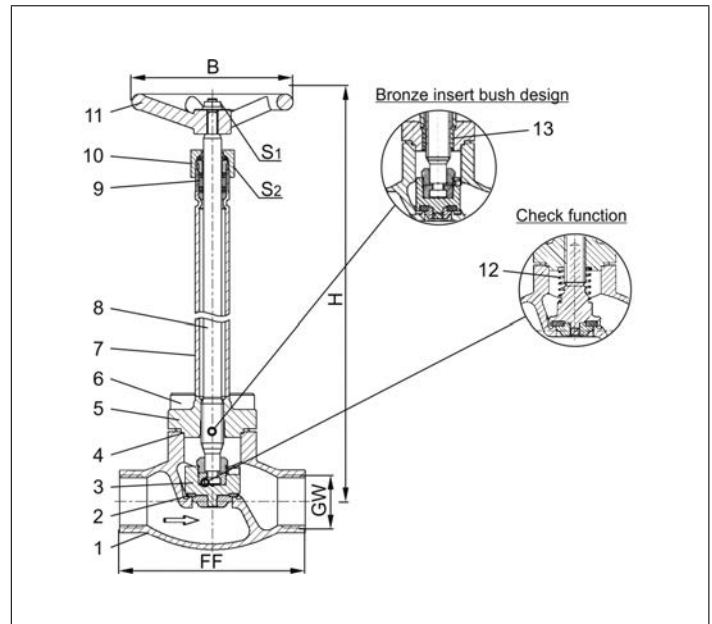

Standard marking acc. to Pressure Equipment Directive 97/23/EC (PED).



Type 01645	Technical data								
	DN	10	10	15	20	25	40	40	50
Nominal size	DN	10	10	15	20	25	40	40	50
Thread size	GW	1/4	3/8	1/2	3/4	1	1-1/4	1-1/2	2
Dimension code	.X.	0200	0300	0400	0600	1000	1200	1400	2000
Face-to-face dimension	FF	70	70	85	100	115	130	130	155
Height	H	270 mm or 370 mm							
Handwheel-Ø	B	100	100	100	100	100	125	125	125
Wrench size across flats	S ₁	10	10	10	10	10	13	13	13
Wrench size across flats	S ₂	30	30	30	30	30	36	36	36
Weight	ca. kg	1.4	1.4	1.7	2.1	2.4	4.7	4.7	7.2
Kvs-Value	m ³ /h	1.6	2.2	4.3	6.7	11.5	20.6	22.6	37.1
Cv-Value	gal/min	1.9	2.6	5.0	7.8	13.4	23.9	26.3	43.2

Dimensions in mm.

Fire Safe Valves

Type 03641 - Globe Valve



Cryogenic-Globe and Globe/Check Valves, PN40
"Fire safe" type test approval acc. to EN ISO 10497

Stainless steel body and topwork,
 "live loaded" gland packing
 "cleaned and degreased for oxygen service"

Part No. 03641.X.0012 (H = 270mm)
Part No. 03641.X.0022 (H = 370mm)
Part No. 03641.X.5012 (H = 270mm) Globe/Check Valve
Part No. 03641.X.5022 (H = 370mm) Globe/Check Valve
 Flanged connection acc. to DIN EN 1092-1 PN40

Available options - on request only:

- Extension H up to 900mm
- Valve with control disc (tapered design)
- Nominal sizes DN15, DN20 and DN150 with welded flange



Applications:

Approved for air gases, vapours and cryogenic liquefied gases incl. LNG.
 Working temperature: -196°C / -321°F (77K) up to +120°C / +248°F (393K)

Materials	DIN EN	ASTM
1 Body	1.4308	A 351 CF8
2 Valve seal	PTFE / Carbon filled (25%)	
3 Disc	1.4301	A 276 Grade 304
4 Bonnet gasket	Graphite	
5 Headpiece	1.4301 / 1.4308	A 276 Grade 304 / A 351 CF8
6 Bolts	1.4301/A2	A 194 B8
7 Elongation tube	1.4541	A 213 TP 321
8 Stem	1.4301	A 276 Grade 304
9 Gland packing	Graphite / PTFE / MICA	
10 Gland nut	1.4305	A 276 Grade 303
11 Handwheel	1.4409	SA 351 CF3M
12 Spring	1.4310	A 313 Grade 301
13 Bush	CW452K	B 159 UNS C51900

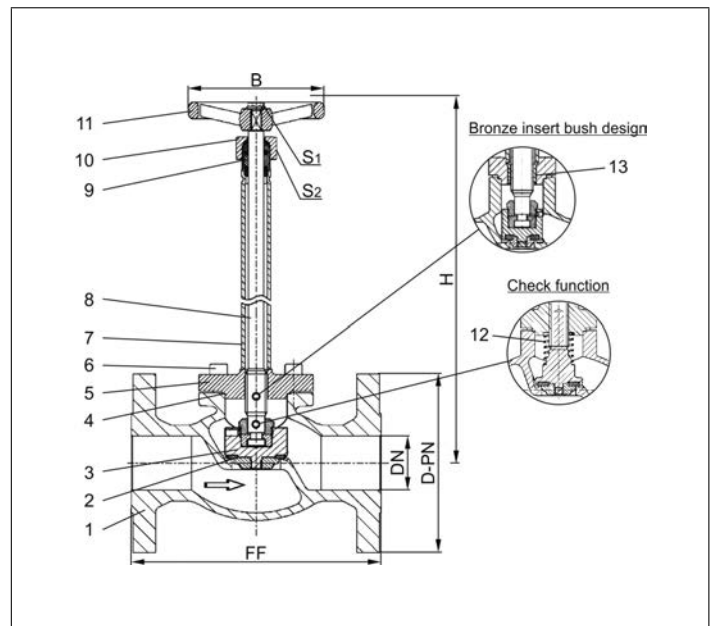

Standard marking acc. to Pressure Equipment Directive 97/23/EC (PED).



Type 03641	Technical data						
	DN	25	40	50	65	80	100
Nominal size	.X.	0250	0400	0500	0650	0800	1000
Dimension code - Flange EN 1092-1 PN40	D-PN	115	150	165	185	200	235
Flange-Ø	FF	160	200	230	290	310	350
Face-to-face dimension	H	270 mm or 370 mm					400
Height	B	100	125	125	200	250	315
Handwheel-Ø	S ₁	10	13	13	13	13	13
Wrench size across flats	S ₂	30	36	36	36	36	41
Weight	ca. kg	4.9	9.7	13.3	21.1	28.0	43.2
Kvs-Value	m ³ /h	11.5	22.6	37.1	71.1	104.0	170.0
Cv-Value	gal/min	13.4	26.3	43.2	82.7	120.9	195.2

Dimensions in mm.



Fire Safe Valves

Type 03641 - Globe Valve



Cryogenic-Globe and Globe/Check Valves, class 300
"Fire safe" type test approval acc. to EN ISO 10497

Stainless steel body and topwork,
 "live loaded" gland packing
 "cleaned and degreased for oxygen service"

Part No. 03641.X.0013 (H = 270mm)
Part No. 03641.X.0023 (H = 370mm)
Part No. 03641.X.5013 (H = 270mm) Globe/Check Valve
Part No. 03641.X.5023 (H = 370mm) Globe/Check Valve
 Flanged connection acc. to ANSI B16.5 class 300

Available options - on request only:

- Extension H up to 900mm
- Valve with control disc (tapered design)
- Nominal sizes DN15, DN20 and DN150 with welded flange



Applications:

Approved for air gases, vapours and cryogenic liquefied gases incl. LNG.
 Working temperature: -196°C / -321°F (77K) up to +120°C / +248°F (393K)

Materials	DIN EN	ASTM
1 Body	1.4308	A 351 CF8
2 Valve seal	PTFE / Carbon filled (25%)	
3 Disc	1.4301	A 276 Grade 304
4 Bonnet gasket	Graphite	
5 Headpiece	1.4301 / 1.4308	A 276 Grade 304 / A 351 CF8
6 Bolts	1.4301/A2	A 194 B8
7 Elongation tube	1.4541	A 213 TP 321
8 Stem	1.4301	A 276 Grade 304
9 Gland packing	Graphite / PTFE / MICA	
10 Gland nut	1.4305	A 276 Grade 303
11 Handwheel	1.4409	SA 351 CF3M
12 Spring	1.4310	A 313 Grade 301
13 Bush	CW452K	B 159 UNS C51900

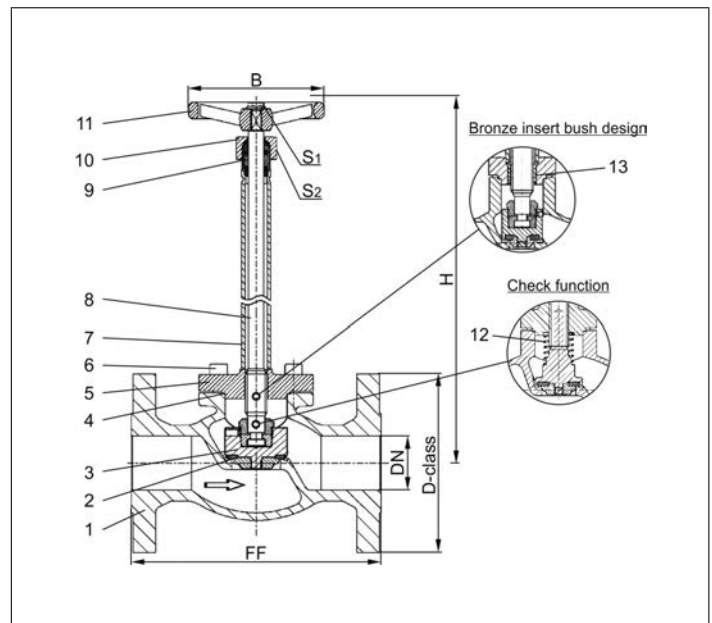

Standard marking acc. to Pressure Equipment Directive 97/23/EC (PED).



Type 03641	Technical data							
	Nominal size	DN	25	40	50	65	80	100
Dimension code - Flange ANSI B16.5 class 300	.X.	1000	1400	2000	2400	3000	4000	
Flange-Ø	D-class	123.9	155.4	165	190.5	209.5	254	
Face-to-face dimension	FF	160	200	230	290	310	350	
Height	H	270 mm or 370 mm						400
Handwheel-Ø	B	100	125	125	200	250	315	
Wrench size across flats	S ₁	10	13	13	13	13	13	
Wrench size across flats	S ₂	30	36	36	36	36	41	
Weight	ca. kg	4.9	9.7	13.3	21.1	28.0	43.2	
Kvs-Value	m ³ /h	11.5	22.6	37.1	71.1	104.0	170.0	
Cv-Value	gal/min	13.4	26.3	43.2	82.7	120.9	195.2	

Dimensions in mm.

Fire Safe Valves

Type 01262 - Bellow Sealed Globe Valve



"Fire-safe"-design without fire type-testing according to EN ISO 10497

Cryogenic-Bellow Sealed Globe Valve, PN50

- Stainless steel body and topwork,
- "live loaded" gland packing
- "cleaned and degreased for oxygen service"

Part No. 01262.X.002*

* Butt weld connection for stainless steel pipes acc. to ISO 1127 or ASTM A312

Part No. 01262.X.0024

Socket weld connection for stainless steel pipes acc. to ISO 1127 or ASTM A312

Available options - on request only:

- Welded stainless steel stubs acc. to ISO 1127 or ASTM A312 - length FF + 200mm
- Extension H up to 900mm



Applications:

Approved for air gases, vapours and cryogenic liquefied gases incl. LNG.
Working temperature: -196°C / -321°F (77K) up to +120°C / +248°F (393K)
Leak rate: 10⁻⁶ mbar ltr / sec outside, 10⁻⁴ mbar ltr / sec seat

Materials	DIN EN	ASTM
1 Body	1.4308	A 351 CF8
2 Valve seal	PTFE / Carbon filled (25%)	
3 Disc	1.4301	A 276 Grade 304
4 Bonnet gasket	Graphite	
5 Headpiece	1.4301	A 276 Grade 304
6 Bellow stem	1.4571	A 313 Grade 316Ti
7 Bolts	1.4301/A2	A 194 B8
8 Bellow	1.4571	A 313 Grade 316Ti
9 Elongation tube	1.4541	A 213 TP 321
10 Headpiece	1.4301	A 276 Grade 304
11 Bush	CW452K	B 159 UNS C51900
12 Stem	1.4301	A 276 Grade 304
13 Gland packing	Graphite / PTFE	
14 Gland nut	1.4305	A 276 Grade 303
15 Handwheel	Aluminium alloy	

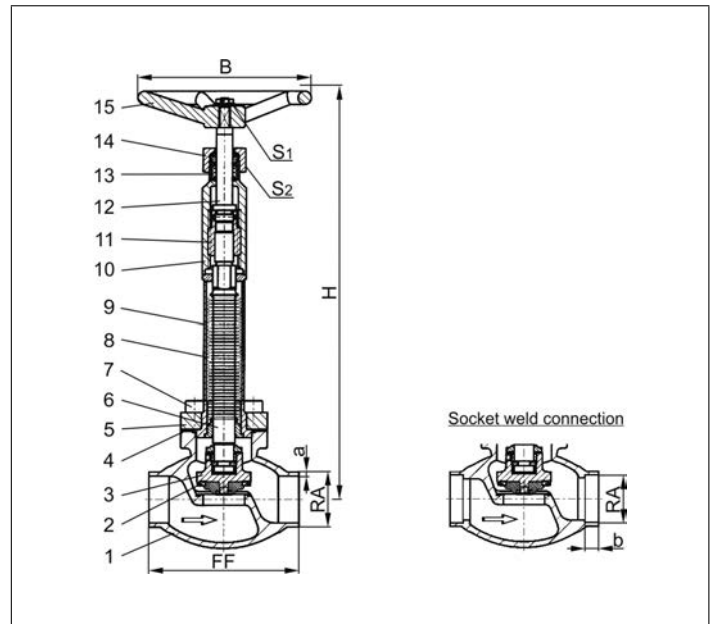

Standard marking acc. to Pressure Equipment Directive 97/23/EC (PED).



Type 01262 - Standard design	Technical data										
Nominal size	DN	10	15	15	20	25	32	40	40	50	
Dimension code	.X.	1012	1517	1521	2026	2533	3238	4042	4048	5060	
Face-to-face dimension	FF	70	85	85	100	115	115	130	130	155	
Height	H	380	380	380	380	380	380	380	380	380	
Outside pipe-Ø ISO 1127	RA	12.0	17.2	21.3	26.9	33.7	38.0	42.4	48.3	60.3	
Wall thickness pipe ISO 1127	a	1.0	1.6	2.0	2.0	2.0	2.0	2.0	2.0	2.0	
Outside pipe-Ø ASTM A312	RA	13.72	17.15	21.34	26.67	33.40	-	42.16	48.26	60.33	
Wall thickness pipe ASTM A312	a	dimensions acc. to S10 or S40									
Socket depth	b	6	10	10	13	13	-	13	13	16	
Handwheel-Ø	B	150	150	150	150	150	150	150	150	150	
Wrench size across flats	S ₁	10	10	10	10	10	13	13	13	13	
Wrench size across flats	S ₂	30	30	30	30	30	36	36	36	36	
Weight	ca. kg	1.6	1.85	1.9	2.3	2.7	3.6	5.1	5.1	7.7	
Kvs-Value	m ³ /h	1.6	2.8	4.3	6.7	11.5	14.0	20.6	22.6	37.1	
Cv-Value	gal/min	1.9	3.3	5.0	7.8	13.4	16.2	26.3	26.3	43.2	

Dimensions in mm.



Fire Safe Valves

Type 01642 - Globe Valve Angle Type



Cryogenic-Globe and Globe/Check Valves, PN50
“Fire safe” type test approval acc. to EN ISO 10497

Stainless steel body and topwork,
 “live loaded” gland packing
 “cleaned and degreased for oxygen service”

Part No. 01642.X.001* (H = 270mm)

Part No. 01642.X.002* (H = 370mm)

* Butt weld connection for stainless steel pipes acc. to ISO 1127 or ASTM A312

Part No. 01642.X.0014 (H = 270mm)

Part No. 01642.X.0024 (H = 370mm)

Socket weld connection for stainless steel pipes acc. to ISO 1127 or ASTM A312

Available options - on request only:

- Extension H up to 900mm



Applications:

Approved for air gases, vapours and cryogenic liquefied gases incl. LNG.

Working temperature: -196°C / -321°F (77K) up to +120°C / +248°F (393K)

Materials	DIN EN	ASTM
1 Body	1.4308	A 351 CF8
2 Valve seal	PTFE / Carbon filled (25%)	
3 Disc	1.4301	A 276 Grade 304
4 Bonnet gasket	Graphite	
5 Headpiece	1.4301 / 14308	A 276 Grade 304 / A 351 CF8
6 Bolts	1.4301/A2	A 194 B8
7 Elongation tube	1.4541	A 213 TP 321
8 Stem	1.4301	A 276 Grade 304
9 Gland packing	Graphite / PTFE / MICA	
10 Gland nut	1.4305	A 276 Grade 303
11 Handwheel	1.4409	SA 351 CF3M
13 Spring	CW452K	B 159 UNS C51900

Standard marking acc. to Pressure Equipment Directive 97/23/EC (PED).

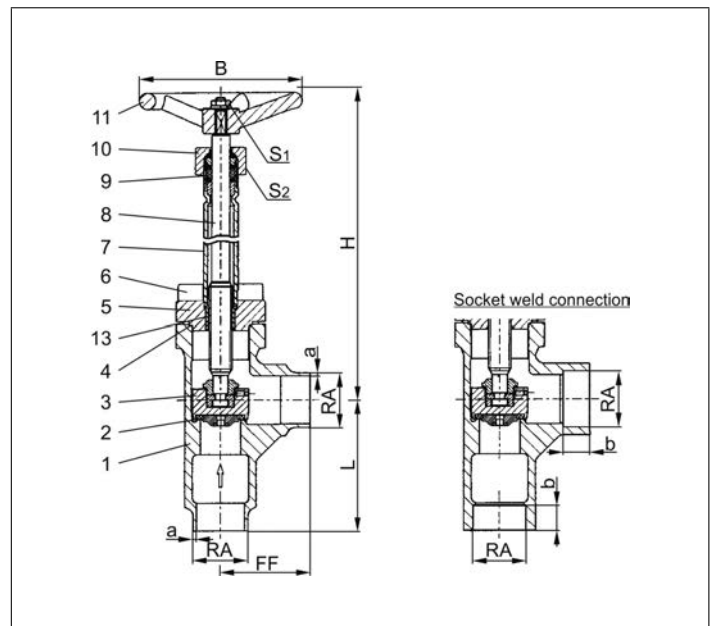

Type 01642 - Standard design	Technical data							
	Nominal size	DN	15	20	25	32	40	50
Dimension code	.X.	1521	2026	2533	3242	4048	5060	
Face-to-face dimension	FF	40	50	55	60	58	85	
Height	H	270 mm or 370 mm						
Outside pipe-Ø ISO 1127	RA	21.3	26.9	33.7	42.0	48.3	60.3	
Wall thickness pipe ISO 1127	a	2.0	2.0	2.0	2.0	2.0	2.0	
Outside pipe-Ø ASTM A312	RA	21.34	26.67	33.40	-	48.26	60.33	
Wall thickness pipe ASTM A312	a	dimensions acc. to S10 or S40						
Socket depth	b	10	13	13	13	13	16	
Handwheel-Ø	B	100	100	100	125	125	125	
Length	L	50	65	80	80	90	90	
Wrench size across flats	S ₁	10	10	10	13	13	13	
Wrench size across flats	S ₂	30	30	30	36	36	36	
Weight	ca. kg	1.4	1.6	2.2	4.0	4.3	6.5	
Kvs-Value	m ³ /h	6.0	10.5	17.2	32.0	35.0	57.0	
Cv-Value	gal/min	7.0	12.2	20.0	37.2	40.7	66.3	

Dimensions in mm.

Fire Safe Valves

Type 15090, Type 15091 - Ball Valve full bore



Cryogenic-3-Piece-Ball Valve

"Fire safe" type test approval acc. to EN ISO 10497

Stainless steel body and topwork,

"live loaded" gland packing

"cleaned and degreased for oxygen service"

with upstream pressure relief hole

Marking acc. to EN 1626, EN 12567, ISO 10497 and ATEX Ex II 2GD

Part No. 15090.X.002*

Socket weld connection for stainless steel pipes acc. to ISO 1127

Part No. 15091.X.002*

Butt weld connection for stainless steel pipes acc. to ISO 1127

Available options - on request only:

- End connection for pipes acc. to ASTM A312 S10/S40
- Stainless steel lockable handle
- With pneumatic actuator



Applications:

Approved for air gases, vapours and cryogenic liquefied gases.

Working temperature: -200°C / -328°F (73K) up to +200°C / +392°F (473K)

Materials	DIN EN	ASTM
1 Body	1.4409	A 351 CF3M
2 Ball seat	PTFE / Carbon filled (25%)	
3 Ball	1.4409	A 351 CF3M
4 Fitting	1.4404	A 276 Grade 316L
5 Flange	1.4306	A 276 Grade 304L
6 Stem	1.4404	A 276 Grade 316L
7 Elongation tube up to DN50	1.4307	304L
7a Elongation tube from 1.4404 DN65	A 276 Grade 316L	
8 Gland packing	Graphite	
9 Lever	1.1181	1035
10 Seal	Graphite	

Standard marking acc. to Pressure Equipment Directive 97/23/EC (PED).

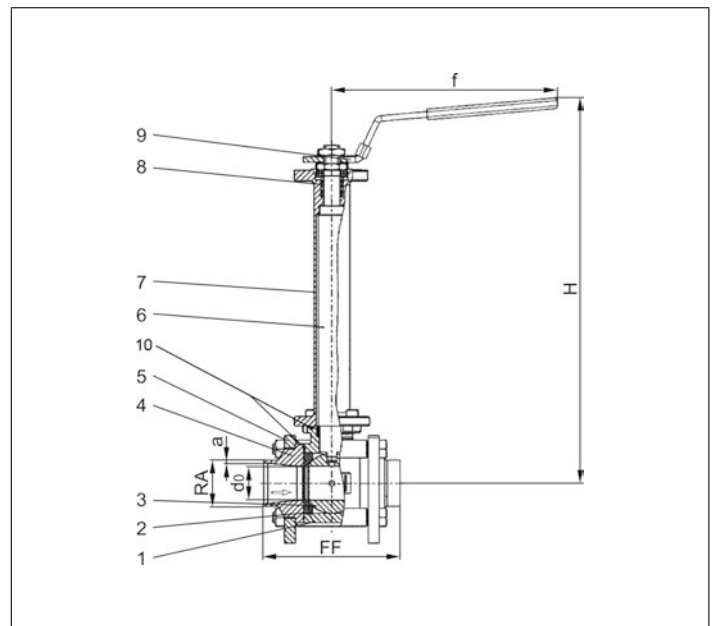

Type 15090, 15091	Technical data											
	DN	8	12	15	20	25	32	40	50	65	80	100
Nominal size	DN	8	12	15	20	25	32	40	50	65	80	100
Dimension code	.X.	0813	1217	1521	2026	2533	3242	4048	5060	6576	8088	0114
Nominal pressure	PN	100	100	100	100	70	70	50	50	40	40	25
Face-to-face dimension	FF	65	65	70	85	100	110	125	150	180	210	230
Height	H	225	225	230	276	280	321	326	346	426	438	471
Outside pipe-Ø ISO 1127	RA	13.5	17.2	21.3	26.9	33.7	42.4	48.3	60.3	76.1	88.9	114.3
Wall thickness pipe ISO 1127	a	2.0	2.0	2.0	2.0	2.0	2.6	2.6	2.9	2.9	2.9	3.2
Orifice	d ₀	11.1	11.1	14.0	19.0	25.0	32.0	38.0	50.0	64.0	76.0	100.0
Length	f	118	118	118	158	158	188	188	225	370	440	505
Weight	ca. kg	1.05	1.05	1.45	2.35	3.05	4.55	6.30	11.10	20.15	32.22	45.00
Kvs-Value	m ³ /h	6.0	8.0	13.0	26.0	46.0	82.0	120.0	223.0	423.0	617.0	1154.0
Cv-Value	gal/min	6.9	9.2	15.0	30.0	53.2	94.8	138.7	257.8	489.0	713.3	1334.0

Dimensions in mm.



Fire Safe Valves

Type 15092, Type 15093 - Ball Valve full bore



Cryogenic-3-Piece-Ball Valve

“Fire safe” type test approval acc. to EN ISO 10497

Stainless steel body and topwork,

"live loaded" gland packing

"cleaned and degreased for oxygen service"

with upstream pressure relief hole

Marking acc. to EN 1626, EN 12567, ISO 10497 and ATEX Ex II 2GD

Part No. 15092.X.0020

Female thread NPT acc. to ANSI B 1.20.1

Part No. 15093.X.0020

Female thread G (BSPP) acc. to ISO 228/1

Available options - on request only:

- Stainless steel lockable handle
- With pneumatic actuator



Applications:

Approved for air gases, vapours and cryogenic liquefied gases.

Working temperature: -200°C / -328°F (73K) up to +200°C / +392°F (473K)

Materials	DIN EN	ASTM
1 Body	1.4409	A 351 CF3M
2 Ball seat	PTFE / Carbon filled (25%)	
3 Ball	1.4409	A 351 CF3M
4 Fitting	1.4404	A 276 Grade 316L
5 Flange	1.4306	A 276 Grade 304L
6 Stem	1.4404	A 276 Grade 316L
7 Elongation tube up to DN50	1.4307	304L
7a Elongation tube from DN65	1.4404	A 276 Grade 316L
8 Gland packing	Graphite	
9 Lever	1.1181	1035
10 Seal	Graphite	

Standard marking acc. to Pressure Equipment Directive 97/23/EC (PED).

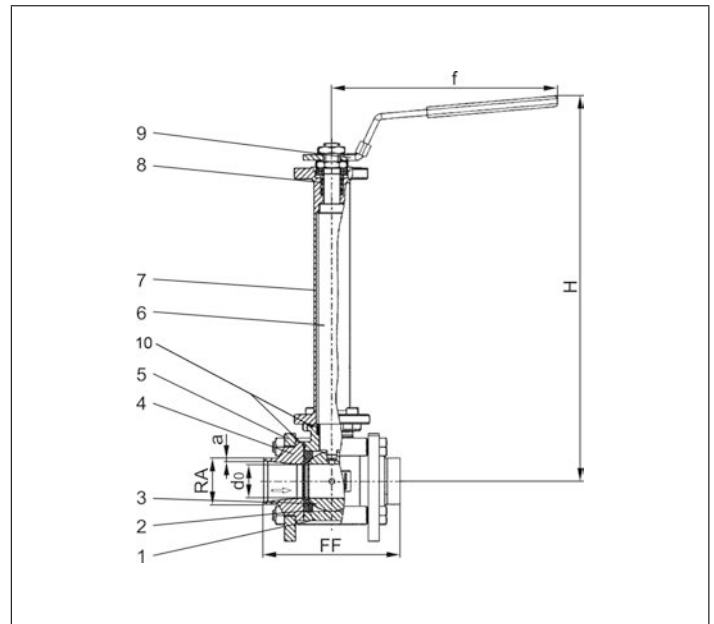

Type 15092, 15093	Technical data											
Nominal size	DN	8	12	15	20	25	32	40	50	65	80	100
Dimension code	.X.	0200	0300	0400	0600	1000	1200	1400	2000	2400	3000	4000
BSPP / NPT	thread	1/4"	3/8"	1/2"	3/4"	1"	1-1/4"	1-1/2"	2"	2-1/2"	3"	4"
Nominal pressure	PN	100	100	100	100	70	70	50	50	40	40	25
Face-to-face dimension	FF	65	65	70	85	100	110	125	150	180	210	230
Height	H	225	225	230	276	280	321	326	346	426	438	471
Orifice	d ₀	11.1	11.1	14.0	19.0	25.0	32.0	38.0	50.0	64.0	76.0	100.0
Length	f	118	118	118	158	158	188	188	225	370	440	505
Weight	ca. kg	1.05	1.05	1.45	2.35	3.05	4.55	6.30	11.10	20.15	32.22	45.00
Kvs-Value	m ³ /h	6.0	8.0	13.0	26.0	46.0	82.0	120.0	223.0	423.0	617.0	1154.0
Cv-Value	gal/min	6.9	9.2	15.0	30.0	53.2	94.8	138.7	257.8	489.0	713.3	1334.0

Dimensions in mm.

Fire Safe Valves

Type 01643 - Actuated Globe Valve



Cryogenic-Globe Valves with Pneumatic Actuator, PN50 (DN100/150=PN40)
“Fire safe” type test approval acc. to EN ISO 10497 (only actuator spring closes)

Stainless steel body and topwork
 Actuator - air opens, spring closes
 “live loaded” gland packing
 “cleaned and degreased for oxygen service” - the actuator is not cleaned and degreased for oxygen

Part No. 01643.X.101*

* Butt weld connection for stainless steel pipes acc. to ISO 1127 or ASTM A312

Part No. 01643.X.1014

Socket weld connection for stainless steel pipes acc. to ISO 1127 or ASTM A312

Available accessories:

- Solenoid valve · Limit switch
- Electropneumatic positioner etc.

Available options - on request only:

- Welded stainless steel stubs acc. to ISO 1127 or ASTM A312 - length FF + 200mm
- Actuator “cleaned and degreased for oxygen service”

Applications:

Approved for air gases, vapours and cryogenic liquefied gases incl. LNG.
 Working temperature: -196°C / -321°F (77K) up to +120°C / +248°F (393K)



Materials	DIN EN	ASTM
1 Body	1.4308	A 351 CF8
2 Valve seal	PTFE / Carbon filled (25%)	
3 Disc	1.4301	A 276 Grade 304
4 Bonnet gasket	Graphite	
5 Headpiece	1.4301	A 276 Grade 304
6 Bolts	1.4301/A2	A 194 B8
7 Elongation tube	1.4541	A 213 TP 321
8 Stem	1.4301	A 276 Grade 304
9 Gland packing	Graphite / PTFE / MICA	
10 Gland nut	1.4305	A 276 Grade 303
11 Pillars	1.4404	A 276 Grade 316L
12 Bush	CW452K	B 159 UNS C51900

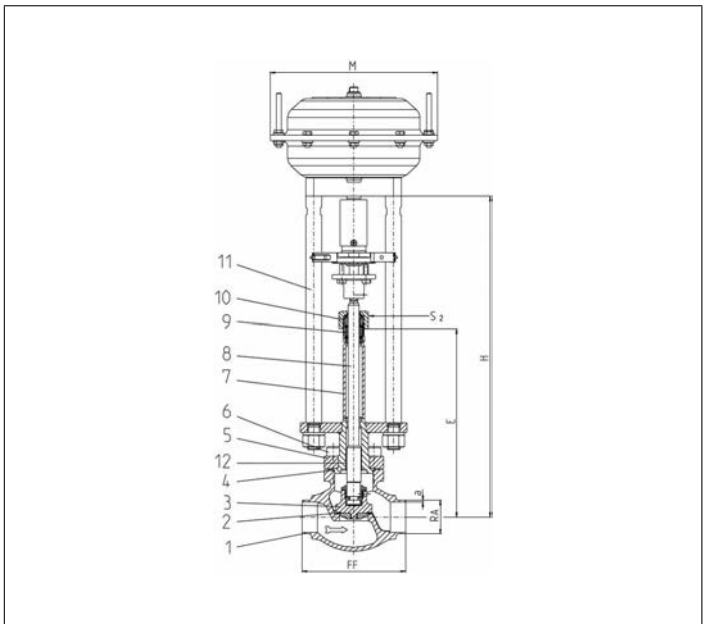

Standard marking acc. to Pressure Equipment Directive 97/23/EC (PED).



Type 01643 - Standard	Technical data													
	DN	10	15	15	20	25	32	40	40	50	65	80	100	150
Nominal size	.X.	1012	1517	1521	2026	2533	3238	4042	4048	5060	657x	8088	0114	0168
Face-to-face dimension	FF	70	85	85	100	115	115	130	130	155	205	245	280	400
Height	H	370	370	370	370	375	405	420	420	425	510	575	635	685
Length	E	195	195	195	200	200	230	230	230	235	300	300	300	300
Outside pipe-Ø ISO 1127	RA	12.0	17.2	21.3	26.9	33.7	38.0	42.4	48.3	60.3	76.1	88.9	114.3	168.3
Wall thickness pipe ISO 1127	a	1.0	1.6	2.0	2.0	2.0	2.0	2.0	2.0	2.0	2.6	3.2	6.0	7.1
Outside pipe-Ø ASTM A312	RA	13.72	17.15	21.34	26.67	33.40	-	42.16	48.26	60.33	73.03	88.90	114.3	168.3
Wall thickness pipe ASTM A312	a	dimensions acc. to S10 or S40												
Socket depth	b	6	10	10	13	13	-	13	13	16	16	16	20	20
Actuator-Ø	M	dependent on actuator												
Wrench size across flats	S ₂	30	30	30	30	30	36	36	36	36	36	36	41	41
Weight w/o actuator	ca. kg	1.9	2.15	2.2	2.4	3.1	3.8	6.5	6.5	9.0	15.2	20.0	28.0	60.9
Kvs-Value	m ³ /h	1.6	3.8	4.3	6.7	11.5	14.0	20.6	22.6	37.1	71.1	104.0	170.0	350.0
Cv-Value	gal/min	1.9	4.4	5.0	7.8	13.4	16.2	23.9	26.3	43.2	82.7	120.9	195.2	401.8
Stroke	mm	10	10	10	7	9	9	11	11	15	23	23	30	40

Dimensions in mm. Compliance of tightness requirements acc. to EN 1626 for DN150 up to 20 bar differential pressure. In the range of >20-40 bar, 350-700ml (1 bar, 20°C [68°F]) are reached.



Fire Safe Valves

Type 01653 - Actuated Trailervalue



Cryogenic-Globe Valves with Pneumatic Actuator, PN50
"Fire safe" type test approval acc. to EN ISO 10497

air pressure for operation 4.0 bar g (maximum 10.0 bar g)

Stainless steel body and topwork,

Actuator - air opens, spring closes

"live loaded" gland packing

"cleaned and degreased for oxygen service" - the actuator is not cleaned and degreased for oxygen

maximum working pressure of the valve depending on nominal size

Part No. 01653.X.T0**

* Butt weld connection for stainless steel pipes acc. to ISO 1127 or ASTM A312

Part No. 01653.X.T0*4

Socket weld connection for stainless steel pipes acc. to ISO 1127 or ASTM A312

Available options - on request only:

· Welded stainless steel stubs acc. to ISO 1127 or ASTM A312 - length FF + 200mm

Applications:

Approved for air gases, vapours and cryogenic liquefied gases incl. LNG.

Working temperature: -196°C / -321°F (77K) up to +120°C / +248°F (393K)



Materials	DIN EN	ASTM
1 Body	1.4308	A 351 CF8
2 Valve seal	PTFE / Carbon filled (25%)	
3 Disc	1.4301	A 276 Grade 304
4 Bonnet gasket	Graphite	
5 Headpiece	1.4301	A 276 Grade 304
6 Bolts	1.4301/A2	A 194 B8
7 Elongation tube	1.4306	A 213 TP 304L
8 Stem	1.4301	A 276 Grade 304
9 Spring	1.4571	A 313 Grade 316Ti
10 Flansch	1.4301	A 276 Grade 304
11 Headpiece	1.4301	A 276 Grade 304
12 Gland packing	Graphite / PTFE / MICA	
13 Gland nut	1.4571	A 313 Grade 316Ti
14 Pillars	1.4301	A 276 Grade 304
15 Bush	CW452K	B 159 UNS C51900
16 Actuator	Rubber	

Standard marking acc. to Pressure Equipment Directive 97/23/EC (PED).

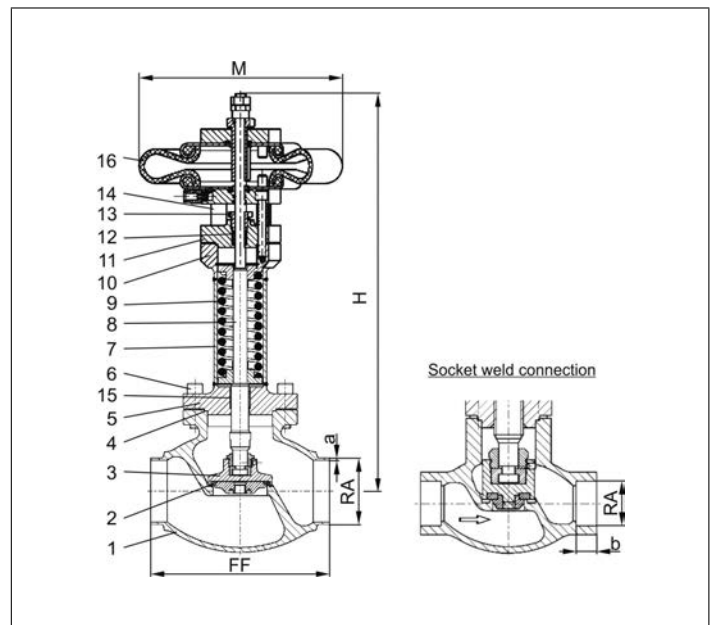

Type 01653	Technical data							
Nominal size	DN	15	25	40	40	50	65	80
Dimension code	.X.	1521	2533	4042	4048	5060	657x	8088
Face-to-face dimension	FF	85	115	130	130	155	205	245
Height	H	395	444	400	400	440	470	500
Outside pipe-Ø ISO 1127	RA	21.3	33.7	42.4	48.3	60.3	76.1	88.9
Wall thickness pipe ISO 1127	a	2.0	2.0	2.0	2.0	2.0	2.6	3.2
Outside pipe-Ø ASTM A312	RA	21.34	33.40	42.16	48.26	60.33	73.03	88.90
Wall thickness pipe ASTM A312	a	dimensions acc. to S10 or S40						
Socket depth	b	10	13	13	13	16	16	16
Actuator-Ø	M	229	229	229	229	229	229	229
Weight	ca. kg	7.2	9.1	10.5	10.5	14.5	17.4	22.5
Kvs-Value	m ³ /h	4.3	11.5	22.6	22.6	37.1	71.1	104.0
Cv-Value	gal/min	5.0	13.4	23.9	26.3	43.2	82.7	120.9
Stroke	mm	10	9	11	11	15	23	23

Dimensions in mm.

Fire Safe Valves

Type 05614 - Check Valve



"Fire-safe"-design without fire type-testing according to EN ISO 10497

Cryogenic-Check Valves, PN50 (DN100/150=PN40)

Stainless steel body and cap
with spring, opening pressure ca. 0.1 bar
"cleaned and degreased for oxygen service"

Part No. 05614.X.0004*

Butt or Socket weld connection for stainless steel pipes acc. to ISO 1127 or ASTM A312
Disc seal: PTFE / Carbon filled (25%)

Part No. 05614.X.005*

Butt or Socket weld connection for stainless steel pipes acc. to ISO 1127 or ASTM A312
Disc seal: PTFE

Available options - on request only:

- Welded stainless steel stubs acc. to ISO 1127 or ASTM A312 - length FF + 200mm



Applications:

Approved for air gases, vapours and cryogenic liquefied gases incl. LNG.
Working temperature: -196°C / -321°F (77K) up to +120°C / +248°F (393K)

Materials	DIN EN	ASTM
1 Body	1.4308	A 351 CF8
2 Valve seal	PTFE / Carbon filled (25%)	
3 Disc	1.4301	A 276 Grade 304
4 Spring	1.4571	A 313 Grade 316Ti
5 Bonnet gasket	Graphite	
6 Bolts	1.4301/A2	A 194 B8
7 Cap	1.4301	A 276 Grade 304

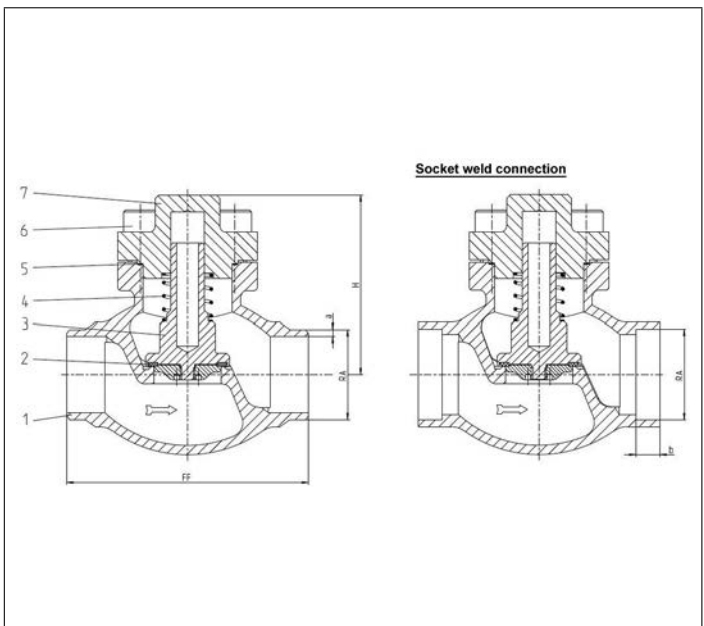

Standard marking acc. to Pressure Equipment Directive 97/23/EC (PED).



Type 05614 - Standard	Technical data														
	Nominal size	DN	10	15	15	20	25	32	40	40	50	65	80	100	150
Dimension code	.X.	1012	1517	1521	2026	2533	3238	4042	4048	5060	657x	8088	0114	0168	
Face-to-face dimension	FF	70	85	85	100	115	115	130	130	155	205	245	280	400	
Height	H	71	71	71	72	75	87	95	95	95	125	150	185	214	
Outside pipe-Ø ISO 1127	RA	12.0	17.2	21.3	26.9	33.7	38.0	42.4	48.3	60.3	76.1	88.9	114.3	168.3	
Wall thickness pipe ISO 1127	a	1.0	1.6	2.0	2.0	2.0	2.0	2.0	2.0	2.0	2.6	3.2	6.0	7.1	
Outside pipe-Ø ASTM A312	RA	13.72	17.15	21.34	26.67	33.40	-	42.16	48.26	60.33	73.03	88.90	114.30	168.30	
Wall thickness pipe ASTM A312	a	dimensions acc. to S10 or S40													
Socket depth	b	6	10	10	13	13	-	13	13	16	16	16	20	20	
Weight	ca. kg	0.7	0.95	1.0	1.3	1.6	2.4	3.9	3.9	5.7	9.6	14.6	20.0	50.0	
Kvs-Value	m ³ /h	1.6	3.8	4.3	6.7	11.5	14.0	20.6	22.6	37.1	71.1	104.0	170.0	350.0	
Cv-Value	gal/mir	1.9	4.4	5.0	7.8	13.4	16.2	23.9	26.3	43.2	82.7	120.9	195.2	401.8	

Dimensions in mm. Compliance of tightness requirements acc. to EN 1626 for DN150 up to 20 bar differential pressure. In the range of >20-40 bar, 350-700ml (1 bar, 20°C [68°F]) are reached.

Offshore Valves

Type 01751 - Globe Valve



Cryogenic-Globe and Globe/Check Valves, PN50 (DN100=PN40)

Stainless steel body and topwork,
 "live loaded" gland packing
 "cleaned and degreased for oxygen service"

Part No. 01751.X.000*

Part No. 01751.X.500* Globe/Check Valve

* Butt weld connection for stainless steel pipes acc. to ISO 1127 or ASTM A312

Part No. 01751.X.0004

Part No. 01751.X.5004 Globe/Check Valve

Socket weld connection for stainless steel pipes acc. to ISO 1127 or ASTM A312

Available options - on request only:

- Welded stainless steel stubs acc. to ISO 1127 or ASTM A312 - length FF + 200mm
- Valve with control disc (tapered design)



Applications:

Suitable for hydrogen, approved for air gases, vapours and cryogenic liquefied gases incl. LNG.

Working temperature: -255°C / -427°F (18K) up to +120°C / +248°F (393K)

Recommended working temperature: -60°C / -76°F (213K) up to +120°C / +248°F (393K)

Materials	DIN EN	ASTM
1 Body	1.4409	A 351 CF3M
2 Valve seal	PCTFE (Kel-F)	
3 Disc	1.4404	A 276 Grade 316L
4 Bonnet gasket	Graphite	
5 Headpiece	1.4404	A 276 Grade 316L
6 Bolts	1.4571/A4	similar A 194 B8T
8 Stem	1.4404	A 276 Grade 316L
9 Gland packing	Graphite / PTFE / MICA	
10 Gland nut	1.4305	A 276 Grade 303
11 Handwheel	1.4409	SA 351 CF3M
12 Spring	1.4571	A 313 Grade 316Ti
13 Bush	CW452K	B 159 UNS C51900

Standard marking acc. to Pressure Equipment Directive 97/23/EC (PED).

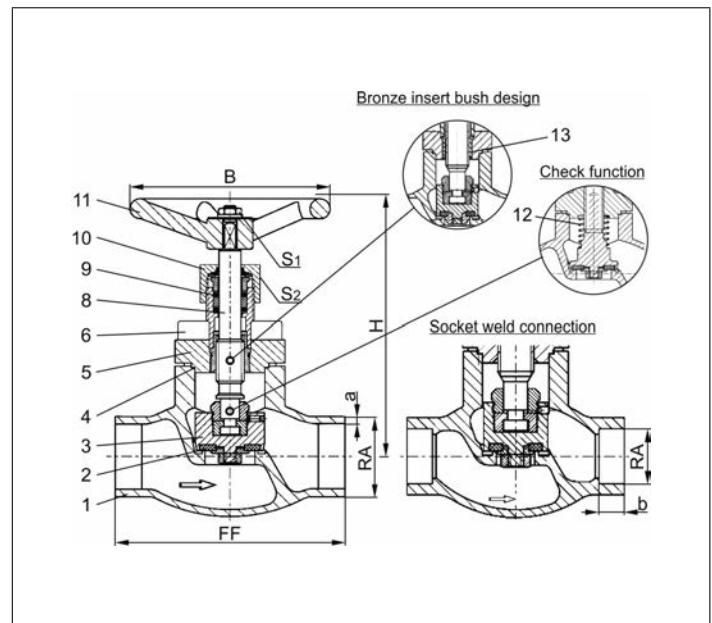

Type 01751 - Standard design	Technical data												
	DN	10	15	15	20	25	32	40	40	50	65	80	100
Nominal size	.X.	1012	1517	1521	2026	2533	3238	4042	4048	5060	657x	8088	0114
Dimension code	.X.	1012	1517	1521	2026	2533	3238	4042	4048	5060	657x	8088	0114
Face-to-face dimension	FF	70	85	85	100	115	115	130	130	155	205	245	280
Height	H	140	140	140	140	140	170	175	175	200	260	310	350
Outside pipe-Ø ISO 1127	RA	12.0	17.2	21.3	26.9	33.7	38.0	42.4	48.3	60.3	76.1	88.9	114.3
Wall thickness pipe ISO 1127	a	1.0	1.6	2.0	2.0	2.0	2.0	2.0	2.0	2.0	2.6	3.2	6.0
Outside pipe-Ø ASTM A312	RA	13.72	17.15	21.34	26.67	33.40	-	42.16	48.26	60.33	73.03	88.90	114.3
Wall thickness pipe ASTM A312	a	dimensions acc. to S10 or S40											
Socket depth	b	6	10	10	13	13	-	13	13	16	16	16	20
Handwheel-Ø	B	100	100	100	100	100	125	125	125	125	200	250	315
Wrench size across flats	S ₁	10	10	10	10	10	13	13	13	13	13	13	13
Wrench size across flats	S ₂	30	30	30	30	30	36	36	36	36	36	36	41
Weight	ca. kg	1.0	1.25	1.3	1.7	2.0	2.8	4.2	4.2	6.7	10.7	16.0	23.0
Kvs-Value	m ³ /h	1.6	3.8	4.3	6.7	11.5	14.0	20.6	22.6	37.1	71.1	104.0	170.0
Cv-Value	gal/min	1.9	4.4	5.0	7.8	13.4	16.2	23.9	26.3	43.2	82.7	120.9	195.2

Dimensions in mm.

Offshore Valves

Type 01755 - Globe Valve



Cryogenic-Globe and Globe/Check Valves, PN50

Stainless steel body and topwork,
 "live loaded" gland packing
 "cleaned and degreased for oxygen service"

Part No. 01755.X.0001

Part No. 01755.X.5001 Globe/Check Valve

Female thread connection (G) acc. to ISO 228/1

Part No. 01755.X.0006

Part No. 01755.X.5006 Globe/Check Valve

Female thread connection NPT acc. to ANSI B 1.20.1

Available options - on request only:

- Female thread connection (R) acc. to ISO 7-Rc
- Valve with control disc (tapered design)



Applications:

Suitable for hydrogen, approved for air gases, vapours and cryogenic liquefied gases incl. LNG.

Working temperature: -255°C / -427°F (18K) up to +120°C / +248°F (393K)

Recommended working temperature: -60°C / -76°F (213K) up to +120°C / +248°F (393K)

Materials	DIN EN	ASTM
1 Body	1.4409	A 351 CF3M
2 Valve seal	PCTFE (Kel-F)	
3 Disc	1.4404	A 276 Grade 316L
4 Bonnet gasket	Graphite	
5 Headpiece	1.4404	A 276 Grade 316L
6 Bolts	1.4571/A4	similar A 194 B8T
8 Stem	1.4404	A 276 Grade 316L
9 Gland packing	Graphite / PTFE / MICA	
10 Gland nut	1.4305	A 276 Grade 303
11 Handwheel	1.4409	SA 351 CF3M
12 Spring	1.4571	A 313 Grade 316Ti
13 Bush	CW452K	B 159 UNS C51900

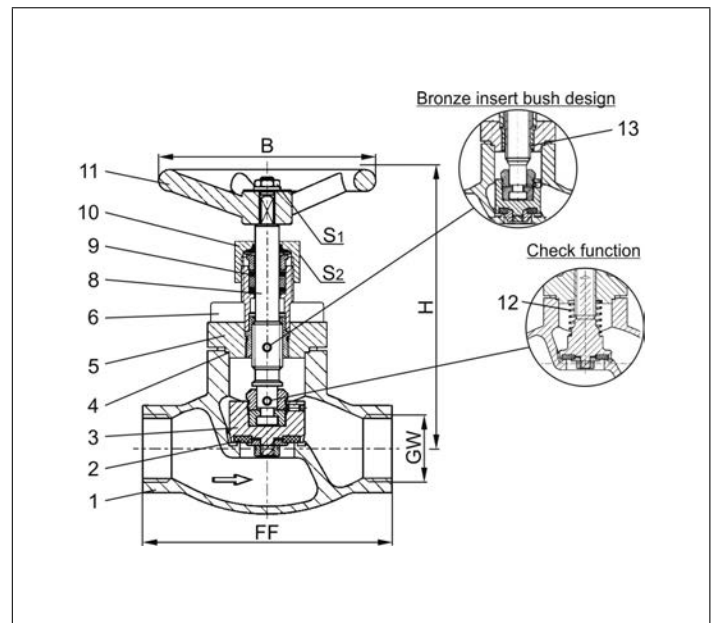

Standard marking acc. to Pressure Equipment Directive 97/23/EC (PED).



Type 01755 - Standard design	Technical data								
Nominal size	DN	10	10	15	20	25	40	40	50
Thread size	GW	1/4	3/8	1/2	3/4	1	1-1/4	1-1/2	2
Dimension code	.X.	0200	0300	0400	0600	1000	1200	1400	2000
Face-to-face dimension	FF	70	70	85	100	115	130	130	155
Height	H	140	140	140	140	140	175	175	200
Handwheel-Ø	B	100	100	100	100	100	125	125	125
Wrench size across flats	S ₁	10	10	10	10	10	13	13	13
Wrench size across flats	S ₂	30	30	30	30	30	36	36	36
Weight	ca. kg	1.0	1.0	1.3	1.7	2.0	4.2	4.2	6.7
Kvs-Value	m ³ /h	1.6	2.2	4.3	6.7	11.5	20.6	22.6	37.1
Cv-Value	gal/min	1.9	2.6	5.0	7.8	13.4	23.9	26.3	43.2

Dimensions in mm.

Offshore Valves

Type 01741 - Globe Valve



Cryogenic-Globe and Globe/Check Valves, PN50 (DN100/150=PN40)

Stainless steel body and topwork,
 "live loaded" gland packing
 "cleaned and degreased for oxygen service"

- Part No. 01741.X.001* (H = 270mm)
- Part No. 01741.X.002* (H = 370mm)
- Part No. 01741.X.501* (H = 270mm) Globe/Check Valve
- Part No. 01741.X.502* (H = 370mm) Globe/Check Valve

* Butt weld connection for stainless steel pipes acc. to ISO 1127 or ASTM A312

- Part No. 01741.X.0014 (H = 270mm)
- Part No. 01741.X.0024 (H = 370mm)
- Part No. 01741.X.5014 (H = 270mm) Globe/Check Valve
- Part No. 01741.X.5024 (H = 370mm) Globe/Check Valve

Socket weld connection for stainless steel pipes acc. to ISO 1127 or ASTM A312

Available options - on request only:

- Extension H up to 900mm
- Valve with control disc (tapered design)

Applications:

Suitable for hydrogen, approved for air gases, vapours and cryogenic liquefied gases incl. LNG.

Working temperature: -255°C / -427°F (18K) up to +120°C / +248°F (393K)



Materials	DIN EN	ASTM
1 Body	1.4409	A 351 CF3M
2 Valve seal	PCTFE (Kel-F)	
3 Disc	1.4404	A 276 Grade 316L
4 Bonnet gasket	Graphite	
5 Headpiece	1.4404	A 276 Grade 316L
6 Bolts	1.4571/A4	similar A 194 B8T
7 Elongation tube	1.4571	A 213 TP 316Ti
8 Stem	1.4404	A 276 Grade 316L
9 Gland packing	Graphite / PTFE / MICA	
10 Gland nut	1.4305	A 276 Grade 303
11 Handwheel	1.4409	SA 351 CF3M
12 Spring	1.4571	A 313 Grade 316Ti
13 Bush	CW452K	B 159 UNS C51900

Standard marking acc. to Pressure Equipment Directive 97/23/EC (PED).

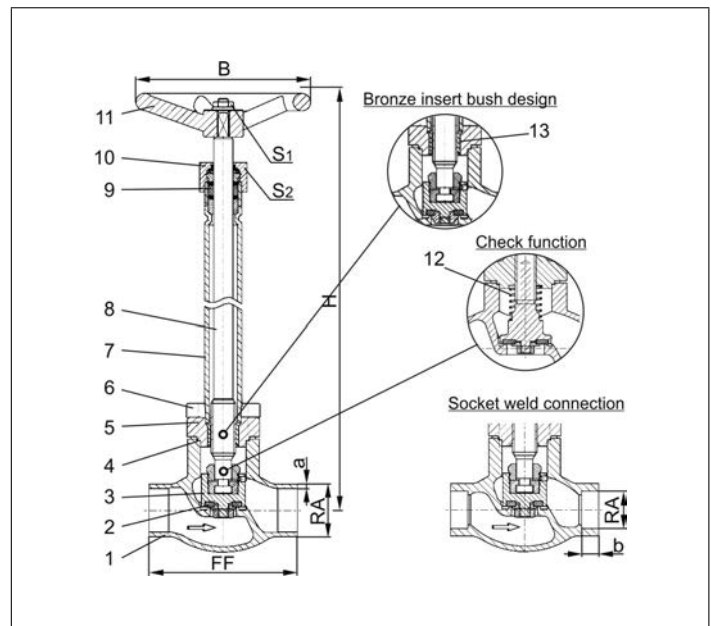

Type 01741 - Standard	Technical data													
	DN	10	15	15	20	25	32	40	40	50	65	80	100	150
Nominal size	.X.	1012	1517	1521	2026	2533	3238	4042	4048	5060	657x	8088	0114	0168
Dimension code	.X.	1012	1517	1521	2026	2533	3238	4042	4048	5060	657x	8088	0114	0168
Face-to-face dimension	FF	70	85	85	100	115	115	130	130	155	205	245	280	400
Height	H	270 mm or 370 mm												
Outside pipe-Ø ISO 1127	RA	12.0	17.2	21.3	26.9	33.7	38.0	42.4	48.3	60.3	76.1	88.9	114.3	168.3
Wall thickness pipe ISO 1127	a	1.0	1.6	2.0	2.0	2.0	2.0	2.0	2.0	2.0	2.6	3.2	6.0	7.1
Outside pipe-Ø ASTM A312	RA	13.72	17.15	21.34	26.67	33.40	-	42.16	48.26	60.33	73.03	88.90	114.3	168.3
Wall thickness pipe ASTM A312	a	dimensions acc. to S10 or S40												
Socket depth	b	6	10	10	13	13	-	13	13	16	16	16	20	20
Handwheel-Ø	B	100	100	100	100	100	125	125	125	125	200	250	315	360
Wrench size across flats	S ₁	10	10	10	10	10	13	13	13	13	13	13	13	19
Wrench size across flats	S ₂	30	30	30	30	30	36	36	36	36	36	36	41	41
Weight	ca. kg	1.4	1.65	1.7	2.1	2.4	3.3	4.7	4.7	7.2	12.7	17.0	24.5	54.0
Kvs-Value	m ³ /h	1.6	3.8	4.3	6.7	11.5	14.0	20.6	22.6	37.1	71.1	104.0	170.0	350.0
Cv-Value	gal/min	1.9	4.4	5.0	7.8	13.4	16.2	23.9	26.3	43.2	82.7	120.9	195.2	401.8

Dimensions in mm.

Offshore Valves

Type 01741 - Globe Valve



Cryogenic Globe Valves, DN200, PN25

Stainless steel body and topwork
"live loaded" gland packing

Part No. 01741.0219.001* (H=560)

Part No. 01741.0219.006* (H=1000)

*Butt weld connection for stainless steel pipes acc. to ISO 1127 or ASTM A312

Artikel-Nr. 01741.0219.00*4

Socket weld connection for stainless steel pipes acc. to ISO 1127 or ASTM A312

In flow direction, the valve with the nominal size DN200 is conform to tightness class L1 up to 9 bar maximum differential pressure acc. to DIN 12567 for LNG use. This standard can also be used for the tightness class of other cryogenic gases.

Available options - on request only

Applications:

Approved for air gases, vapours and cryogenic liquefied gases incl. LNG.

Working temperature: -196°C / -321°F (77K) up to +120°C / +248°F (393K)



Materials	DIN EN	ASTM
1 Body	1.4409	A 351 CF3M
2 Valve seal	PCTFE (Kel-F)	
3 Disc	1.4404	A 276 Grade 316L
4 Bonnet gasket	Graphite	
5 Headpiece	1.4404	A 276 Grade 316L
6 Bolts	1.4571/A4	similar A 194 B8T
7 Elongation tube	1.4571	A 213 TP 316Ti
8 Stem	1.4404	A 276 Grade 316L
9 Gland packing	Graphite / PTFE / MICA	
10 Gland nut	1.4305	A 276 Grade 303
11 Handwheel	1.4409	A 351 CF3M
13 Bush	CW452K	B 159 UNS C51900

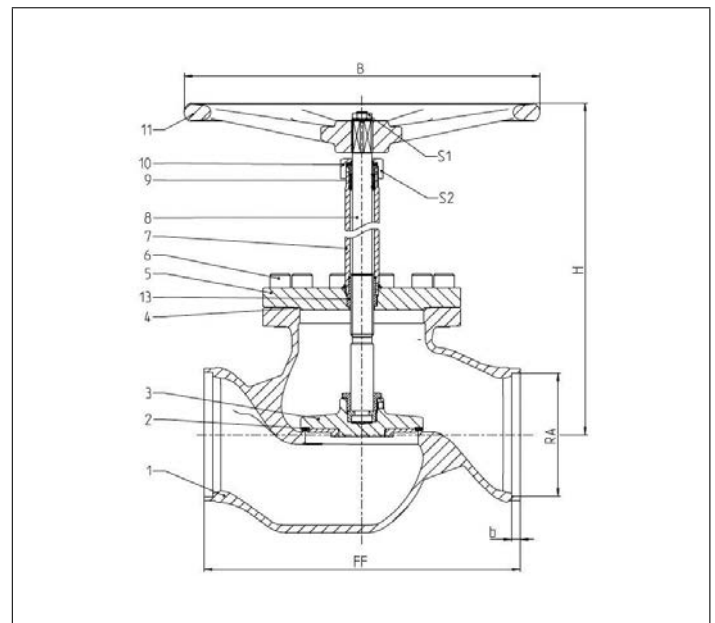

Standard marking acc. to Pressure Equipment Directive 97/23/EC (PED).



Type 01741 - Standard	Technical data	
Nominal size	DN	200
Dimension code	.X.	0219
Face-to-face dimension	FF	560
Height	H	1000
Outside pipe-Ø ISO 1127	RA	219.1
Wall thickness pipe ISO 1127	a	6.3
Outside pipe-Ø ASTM A312	RA	219.1
Wall thickness pipe ASTM A312	a	dimensions acc. to S10 or S40
Socket depth	b	15
Handwheel-Ø	B	630
Wrench size across flats	S ₁	30
Wrench size across flats	S ₂	65
Weight	ca. kg	135
Kvs-Value	m ³ /h	680
Cv-Value	gal/min	786

Dimensions in mm.



Offshore Valves

Type 01745 - Globe Valve



Cryogenic-Globe and Globe/Check Valves, PN50

Stainless steel body and topwork,
 "live loaded" gland packing
 "cleaned and degreased for oxygen service"

Part No. 01745.X.0011 (H = 270mm)
Part No. 01745.X.0021 (H = 370mm)
Part No. 01745.X.5011 (H = 270mm) Globe/Check Valve
Part No. 01745.X.5021 (H = 370mm) Globe/Check Valve
 Female thread connection (G) acc. to ISO 228/1

Part No. 01745.X.0016 (H = 270mm)
Part No. 01745.X.0026 (H = 370mm)
Part No. 01745.X.5016 (H = 270mm) Globe/Check Valve
Part No. 01745.X.5026 (H = 370mm) Globe/Check Valve
 Female thread connection NPT acc. to ANSI B 1.20.1

Available options - on request only:
 · Female thread connection (R) acc. to ISO 7-Rc
 · Extension H up to 900mm
 · Valve with control disc (tapered design)

Applications:

Suitable for hydrogen, approved for air gases, vapours and cryogenic liquefied gases incl. LNG.
 Working temperature: -255°C / -427°F (18K) up to +120°C / +248°F (393K)



Materials	DIN EN	ASTM
1 Body	1.4409	A 351 CF3M
2 Valve seal	PCTFE (Kel-F)	
3 Disc	1.4404	A 276 Grade 316L
4 Bonnet gasket	Graphite	
5 Headpiece	1.4404	A 276 Grade
6 Bolts	1.4571/A4	similar A 194
7 Elongation tube	1.4571	A 213 TP 316Ti
8 Stem	1.4404	A 276 Grade 316L
9 Gland packing	Graphite / PTFE / MICA	
10 Gland nut	1.4305	A 276 Grade 303
11 Handwheel	1.4409	SA 351 CF3M
12 Spring	1.4571	A 313 Grade 316Ti
13 Bush	CW452K	B 159 UNS C51900

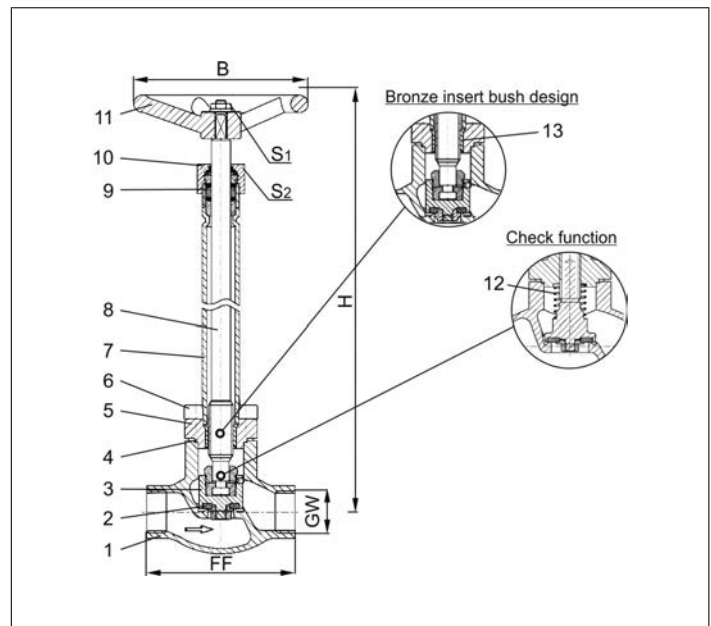

Standard marking acc. to Pressure Equipment Directive 97/23/EC (PED).



Type 01745	Technical data									
Nominal size	DN	10	10	15	20	25	40	40	50	
Thread size	GW	1/4	3/8	1/2	3/4	1	1-1/4	1-1/2	2	
Dimension code	.X.	0200	0300	0400	0600	1000	1200	1400	2000	
Face-to-face dimension	FF	70	70	85	100	115	130	130	155	
Height	H	270 mm or 370 mm								
Handwheel-Ø	B	100	100	100	100	100	125	125	125	
Wrench size across flats	S ₁	10	10	10	10	10	13	13	13	
Wrench size across flats	S ₂	30	30	30	30	30	36	36	36	
Weight	ca. kg	1.4	1.4	1.7	2.1	2.4	4.7	4.7	7.2	
Kvs-Value	m ³ /h	1.6	2.2	4.3	6.7	11.5	20.6	22.6	37.1	
Cv-Value	gal/min	1.9	2.6	5.0	7.8	13.4	23.9	26.3	43.2	

Dimensions in mm.

Cryogenic-Bellow Sealed Globe Valve, PN50

Stainless steel body and topwork,
 "live loaded" gland packing
 "cleaned and degreased for oxygen service"

Part No. 01272.X.002*

* Butt weld connection for stainless steel pipes acc. to ISO 1127 or ASTM A312

Part No. 01272.X.0024

Socket weld connection for stainless steel pipes acc. to ISO 1127 or ASTM A312

Available options - on request only:

- Welded stainless steel stubs acc. to ISO 1127 or ASTM A312 - length FF + 200mm
- Extension H up to 900mm
- Valve with control disc (tapered design)



Applications:

Suitable for hydrogen, approved for air gases, vapours and cryogenic liquefied gases incl. LNG.

Working temperature: -255°C / -427°F (18K) up to +120°C / +248°F (393K)

Leak rate: 10^{-6} mbar ltr / sec outside, 10^{-4} mbar ltr / sec seat

Materials	DIN EN	ASTM
1 Body	1.4409	A 351 CF3M
2 Valve seal	PCTFE (Kel-F)	
3 Disc	1.4404	A 276 Grade 316L
4 Bonnet gasket	Graphite	
5 Headpiece	1.4404	A 276 Grade 316L
6 Bellow stem	1.4571	A 313 Grade 316Ti
7 Bolts	1.4571/A4	similar A 194 B8T
8 Bellow	1.4571	A 313 Grade 316Ti
9 Elongation tube	1.4571	A 313 Grade 316Ti
10 Headpiece	1.4404	A 276 Grade 316L
11 Bush	CW452K	B 159 UNS C51900
12 Stem	1.4404	A 276 Grade 316L
13 Gland packing	Graphite / PTFE / MICA	
14 Gland nut	1.4404	A 276 Grade 316L
15 Handwheel	Aluminium alloy	

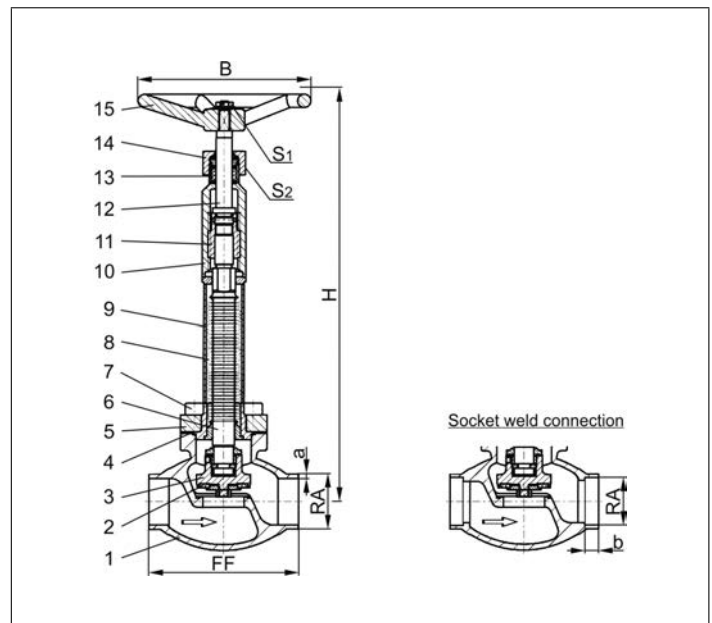

Standard marking acc. to Pressure Equipment Directive 97/23/EC (PED).



Type 01272 - Standard design	Technical data									
Nominal size	DN	10	15	15	20	25	32	40	40	50
Dimension code	.X.	1012	1517	1521	2026	2533	3238	4042	4048	5060
Face-to-face dimension	FF	70	85	85	100	115	115	130	130	155
Height	H	380	380	380	380	380	380	380	380	380
Outside pipe-Ø ISO 1127	RA	12.0	17.2	21.3	26.9	33.7	38.0	42.4	48.3	60.3
Wall thickness pipe ISO 1127	a	1.0	1.6	2.0	2.0	2.0	2.0	2.0	2.0	2.0
Outside pipe-Ø ASTM A312	RA	13.72	17.15	21.34	26.67	33.40	-	42.16	48.26	60.33
Wall thickness pipe ASTM A312	a	dimensions acc. to S10 or S40								
Socket depth	b	6	10	10	13	13	-	13	13	16
Handwheel-Ø	B	150	150	150	150	150	150	150	150	150
Wrench size across flats	S ₁	10	10	10	10	10	13	13	13	13
Wrench size across flats	S ₂	30	30	30	30	30	36	36	36	36
Weight	ca. kg	1.6	1.85	1.9	2.3	2.7	3.6	5.1	5.1	7.7
Kvs-Value	m ³ /h	1.6	2.8	4.3	6.7	11.5	14.0	20.6	22.6	37.1
Cv-Value	gal/min	1.9	3.3	5.0	7.8	13.4	16.2	26.3	26.3	43.2

Dimensions in mm.

Offshore Valves

Type 01743 - Actuated Globe Valve



Cryogenic-Globe Valves with Pneumatic Actuator, PN50 (DN100/150=PN40)

Stainless steel body and topwork

Actuator - air opens, spring closes or contrary

"live loaded" gland packing

"cleaned and degreased for oxygen service" - the actuator is not cleaned and degreased for oxygen

Part No. 01743.X.301*

Butt weld connection for stainless steel pipes acc. to ISO 1127 or ASTM A312

Part No. 01743.X.3014

Socket weld connection for stainless steel pipes acc. to ISO 1127 or ASTM A312

Available accessories:

- Solenoid valve · Limit switch
- Electropneumatic positioner etc.

Available options - on request only:

- Welded stainless steel stubs acc. to ISO 1127 or ASTM A312 - length FF + 200mm
- Actuator "cleaned and degreased for oxygen service"
- Electric actuator · Valve with check disc, valve with control disc (tapered design)



Applications:

Approved for air gases, vapours and cryogenic liquefied gases incl. LNG.

Working temperature: -255°C / -427°F (18K) up to +120°C / +248°F (393K)

Materials	DIN EN	ASTM
1 Body	1.4409	A 351 CF3M
2 Valve seal	PCTFE (Kel-F)	
3 Disc	1.4404	A 276 Grade 316L
4 Bonnet gasket	Graphite	
5 Headpiece	1.4404	A 276 Grade 316L
6 Bolts	1.4571/A4	similar A 194 B8T
7 Elongation tube	1.4571	A 213 TP 316Ti
8 Stem	1.4404	A 276 Grade 316L
9 Gland packing	Graphite / PTFE / MICA	
10 Gland nut	1.4404	A 276 Grade 316L
11 Pillars	1.4404	A 276 Grade 316L
12 Bush	CW452K	B 159 UNS C51900

Standard marking acc. to Pressure Equipment Directive 97/23/EC (PED).

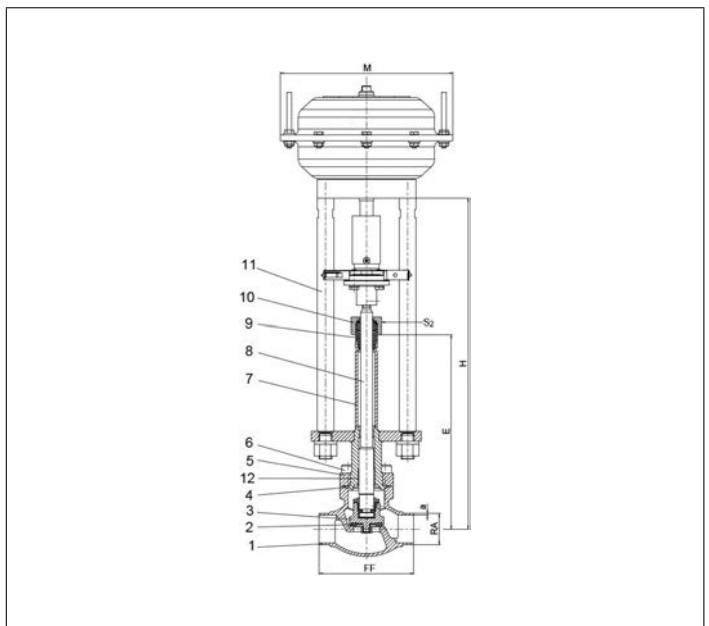

Type 01743 - Standard	Technical data														
	DN	10	15	15	20	25	32	40	40	50	65	80	100	150	
Nominal size	DN	10	15	15	20	25	32	40	40	50	65	80	100	150	
Dimension code	.X.	1012	1517	1521	2026	2533	3238	4042	4048	5060	657x	8088	0114	0168	
Face-to-face dimension	FF	70	85	85	100	115	115	130	130	155	205	245	280	400	
Height	H	370	370	370	370	375	405	420	420	425	510	575	635	685	
Length	E	195	195	195	200	200	230	230	230	235	300	300	300	300	
Outside pipe-Ø ISO 1127	RA	12.0	17.2	21.3	26.9	33.7	38.0	42.4	48.3	60.3	76.1	88.9	114.3	168.3	
Wall thickness pipe ISO 1127	a	1.0	1.6	2.0	2.0	2.0	2.0	2.0	2.0	2.0	2.6	3.2	6.0	7.1	
Outside pipe-Ø ASTM A312	RA	13.72	17.15	21.34	26.67	33.40	-	42.16	48.26	60.33	73.03	88.90	114.3	168.3	
Wall thickness pipe ASTM A312	a	dimensions acc. to S10 or S40													
Socket depth	b	6	10	10	13	13	-	13	13	16	16	16	20	20	
Actuator-Ø	M	dependent on actuator													
Wrench size across flats	S ₂	30	30	30	30	30	36	36	36	36	36	36	41	41	
Weight w/o actuator	ca. kg	1.9	2.15	2.2	2.4	3.1	3.8	6.5	6.5	9.0	15.2	20.0	28.0	60.9	
Kvs-Value	m ³ /h	1.6	3.8	4.3	6.7	11.5	14.0	20.6	22.6	37.1	71.1	104.0	170.0	350.0	
Cv-Value	gal/min	1.9	4.4	5.0	7.8	13.4	16.2	23.9	26.3	43.2	82.7	120.9	195.2	401.8	
Stroke	mm	10	10	10	7	9	9	11	11	15	23	23	30	40	

Dimensions in mm. Compliance of tightness requirements acc. to EN 1626 for DN150 up to 20 bar differential pressure. In the range of >20-40 bar, 350-700ml (1 bar, 20°C [68°F]) are reached.

Offshore Valves

Type 01753 - Actuated Trailervalue



Cryogenic-Globe Valves with Pneumatic Actuator, PN50

air pressure for operation 4.0 bar g (maximum 10.0 bar g)

Stainless steel body and topwork,

Actuator - air opens, spring closes

"live loaded" gland packing

"cleaned and degreased for oxygen service" - the actuator is not cleaned and degreased for oxygen

maximum working pressure of the valve depending on nominal size

Part No. 01753.X.T0**

* Butt weld connection for stainless steel pipes acc. to ISO 1127 or ASTM A312

Part No. 01753.X.T0*4

Socket weld connection for stainless steel pipes acc. to ISO 1127 or ASTM A312

Available options - on request only:

· Welded stainless steel stubs acc. to ISO 1127 or ASTM A312 - length FF + 200mm



Applications:

Approved for air gases, vapours and cryogenic liquefied gases incl. LNG.

Working temperature: -255°C / -427°F (18K) up to +120°C / +248°F (393K)

Materials	DIN EN	ASTM
1 Body	1.4409	A 351 CF3M
2 Valve seal	PCTFE (Kel-F)	
3 Disc	1.4404	A 276 Grade 316L
4 Bonnet gasket	Graphite	
5 Headpiece	1.4404	A 276 Grade 316L
6 Bolts	1.4571/A4	similar A 194
7 Elongation tube	1.4571	A 213 TP 316Ti
8 Stem	1.4404	A 276 Grade 316L
9 Spring	1.4571	A 313 Grade 316Ti
10 Flange	1.4404	A 276 Grade 316L
11 Headpiece	1.4404	A 276 Grade 316L
12 Gland packing	Graphite / PTFE / MICA	
13 Gland nut	1.4571	A 313 Grade 316Ti
14 Pillars	1.4404	A 276 Grade 316L
15 Bush	CW452K	B 159 UNS C51900
16 Actuator	Rubber	

Standard marking acc. to Pressure Equipment Directive 97/23/EC (PED).

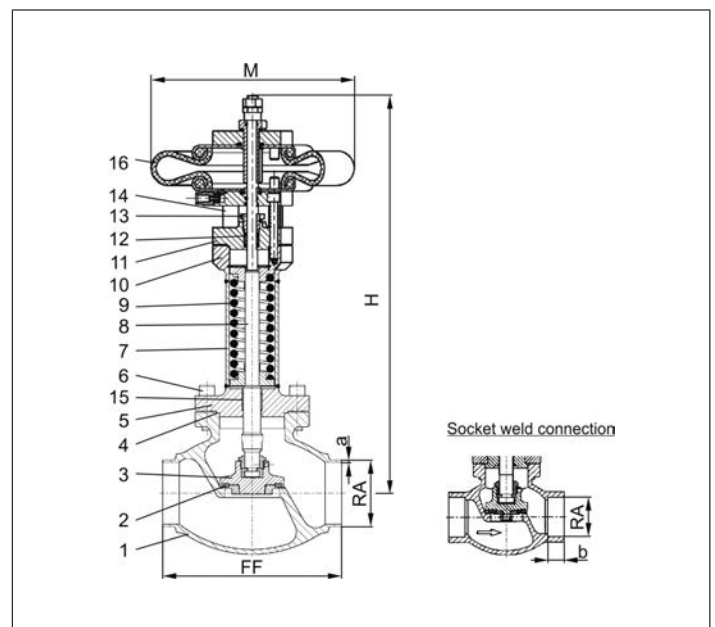

Type 01753	Technical data							
Nominal size	DN	15	25	40	40	50	65	80
Dimension code	.X.	1521	2533	4042	4048	5060	657x	8088
Face-to-face dimension	FF	85	115	130	130	155	205	245
Height	H	395	444	400	400	440	470	500
Outside pipe-Ø ISO 1127	RA	21.3	33.7	42.4	48.3	60.3	76.1	88.9
Wall thickness pipe ISO 1127	a	2.0	2.0	2.0	2.0	2.0	2.6	3.2
Outside pipe-Ø ASTM A312	RA	21.34	33.40	42.16	48.26	60.33	73.03	88.90
Wall thickness pipe ASTM A312	a	dimensions acc. to S10 or S40						
Socket depth	b	10	13	13	13	16	16	16
Actuator-Ø	M	229	229	229	229	229	229	229
Weight	ca. kg	7.2	9.1	10.5	10.5	14.5	17.4	22.5
Kvs-Value	m ³ /h	4.3	11.5	22.6	22.6	37.1	71.1	104.0
Cv-Value	gal/min	5.0	13.4	23.9	26.3	43.2	82.7	120.9
Stroke	mm	10	9	11	11	15	23	23

Dimensions in mm.

Offshore Valves

Type 27521 - Pneumatic Actuator - Globe Valve (on/off)



Pneumatic Actuators for Globe Valves (on/off)

Actuator - air to open, **spring to close**

maximum air pressure for operation 6.0 bar g

"cleaned and degreased for oxygen service"

Available options - on request only:

· Pneumatic actuator with override handwheel

Ambient temperature limit: -40°C / -40°F (233K) up to +80°C / 176°F (353K)



Overview - required actuator sizes for differential pressures

Valve size	Differential pressure in bar												
	0	3.1	4.1	7.1	10.1	11.1	15.1	18.1	20.1	22.1	30.1	33.1	35.1
	3.0	4.0	7.0	10.0	11.0	15.0	18.0	20.0	22.0	30.0	33.0	35.0	50.0
DN 10	B	B	B	B	B	B	B	B	B	B	B	B	B
DN 15	B	B	B	B	B	B	B	B	B	B	B	B	B
DN 20	B	B	B	B	B	B	B	B	B	B	B	B	B
DN 25	B	B	B	B	B	B	B	B	B	B	B	B	B
DN 32	B	B	B	B	B	B	B	B	B	B	B	B	C
DN 40	B	B	B	B	B	B	B	B	B	C	C	C	C
DN 50	B	B	B	B	B	B	C	C	C	C	C	C	-
DN 65	B	B	B	C	C	C	C	-	-	-	-	-	-
DN 80	B	B	C	C	-	-	-	-	-	-	-	-	-
DN 100	B	-	-	-	-	-	-	-	-	-	-	-	-
DN 150	-	-	-	-	-	-	-	-	-	-	-	-	-

Code in Table	Part No.	Actuator
B	27521.35B6.6GPO	
C	27521.60A6.6GPO	

Materials	DIN EN	ASTM
1 Body	1.4571	A 240 Grade 316Ti
2 Body	1.4571	A 240 Grade 316Ti
3 Diaphragm	EPDM	
4 Springs	1.7102	AISI 9254
5 Actuator stem	1.4404	A 276 Grade 316L
6 Coupling	1.4571	A 240 Grade 316Ti

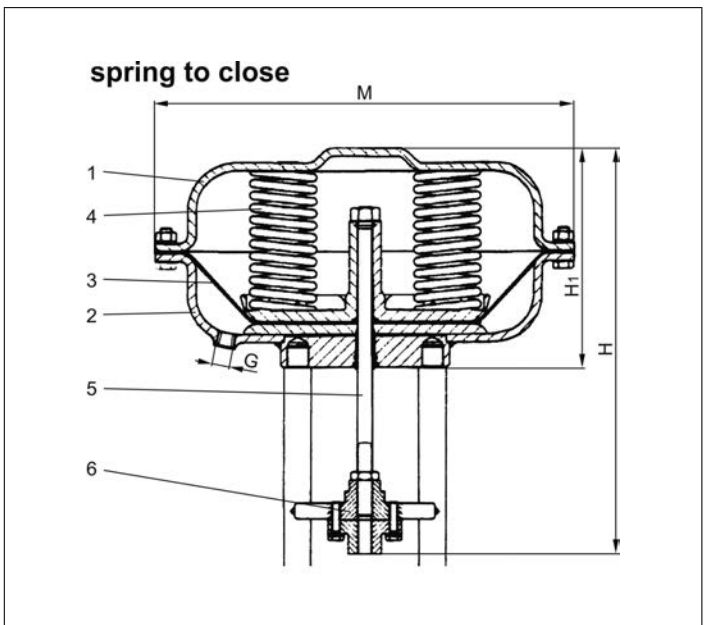

Type 27521	Technical data		
Part No. Actuator	27521		
	.35B6.6GPO	.60A6.6GPO	
Diameter Actuator	M	210	310
Height	H	276	309
Height	H1	136	166
Thread	G	1/4" NPT	1/4" NPT
Diaphragm area	cm ²	280	530
Spring rage	bar	0.8 - 3.0	0.8 - 2.8
Regulating lift	mm	35	40
Weight	ca. kg	5.0	12.5

Dimensions in mm.

Offshore Valves

Type 27521 - Pneumatic Actuator - Control Valve



Pneumatic Actuators for Control Valves

Actuator - air to open, **spring to close**

maximum air pressure for operation 6.0 bar g

"cleaned and degreased for oxygen service"

Available options - on request only:

· Pneumatic actuator with override handwheel

Ambient temperature limit: -40°C / -40°F (233K) up to +80°C / 176°F (353K)

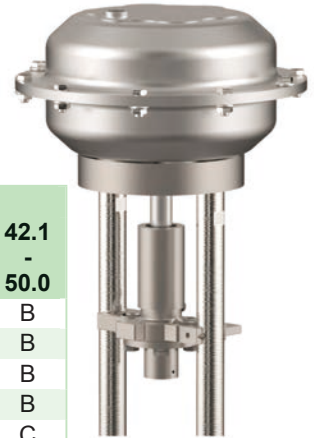

Overview - required actuator sizes for differential pressures

Valve size	Differential pressure in bar															
	0	2.1	4.1	6.1	8.1	10.1	12.1	15.1	17.1	19.1	22.1	25.1	29.1	35.1	39.1	42.1
	2.0	4.0	6.0	8.0	10.0	12.0	15.0	17.0	19.0	22.0	25.0	29.0	35.0	39.0	42.0	50.0
DN 10	B	B	B	B	B	B	B	B	B	B	B	B	B	B	B	B
DN 15	B	B	B	B	B	B	B	B	B	B	B	B	B	B	B	B
DN 20	B	B	B	B	B	B	B	B	B	B	B	B	B	B	B	B
DN 25	B	B	B	B	B	B	B	B	B	B	B	B	B	B	B	B
DN 32	B	B	B	B	B	B	B	B	B	B	C	C	C	C	C	C
DN 40	B	B	B	B	B	B	B	C	C	C	C	C	C	C	D	-
DN 50	B	B	B	B	B	C	C	C	C	C	C	D	D	-	-	-
DN 65	C	C	C	C	C	C	-	-	-	-	-	-	-	-	-	-
DN 80	C	C	C	-	-	-	-	-	-	-	-	-	-	-	-	-
DN 100	C	C	-	-	-	-	-	-	-	-	-	-	-	-	-	-
DN 150	-	-	-	-	-	-	-	-	-	-	-	-	-	-	-	-

Code in Table	Part No.	Actuator
B	27521.35B6.6GPO	
C	27521.60A6.6GPO	

Materials	DIN EN	ASTM
1 Body	1.4571	A 240 Grade 316Ti
2 Body	1.4571	A 240 Grade 316Ti
3 Diaphragm	EPDM	
4 Springs	1.7102	AISI 9254
5 Actuator stem	1.4404	A 276 Grade 316L
6 Coupling	1.4571	A 240 Grade 316Ti

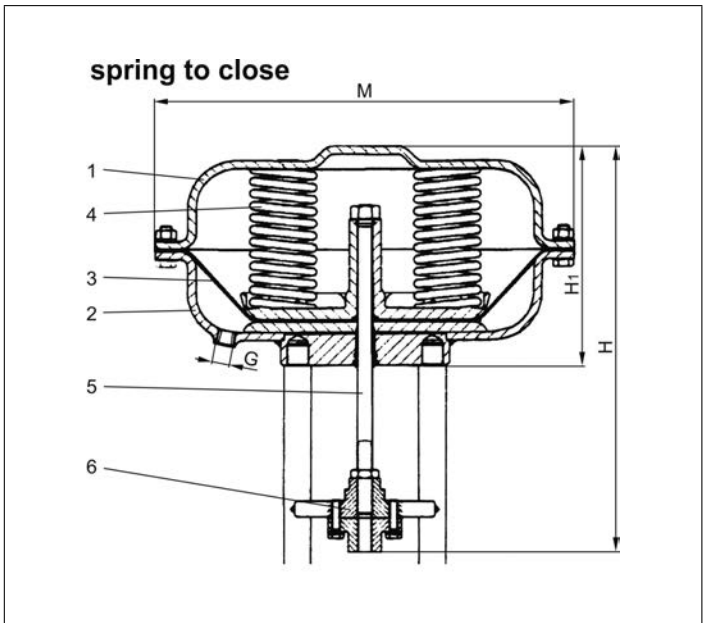

Type 27521	Technical data		
Part No. Actuator	27521		
	.35B6.6GPO	.60A6.6GPO	
Diameter Actuator	M	210	310
Height	H	276	309
Height	H1	136	166
Thread	G	1/4" NPT	1/4" NPT
Diaphragm area	cm ²	280	530
Spring rage	bar	0.8 - 3.0	0.8 - 2.8
Regulating lift	mm	35	40
Weight	ca. kg	5.0	12.5

Dimensions in mm.



Offshore Valves

Type 27522 - Pneumatic Actuator - Globe Valve (on/off)



Pneumatic Actuators for Globe Valves (on/off)

Actuator - **spring to open**, air to close

maximum air pressure for operation 6.0 bar g

"cleaned and degreased for oxygen service"

Available options - on request only:

· Pneumatic actuator with override handwheel

Ambient temperature limit: -40°C / -40°F (233K) up to +80°C / 176°F (353K)

Overview - required actuator sizes for differential pressures

Valve size	Differential pressure in bar											
	0	5.1	7.1	14.1	17.1	19.1	22.1	26.1	29.1	35.1	37.1	45.1
	5.0	7.0	14.0	17.0	19.0	22.0	26.0	29.0	35.0	37.0	45.0	50.0
DN 10	B	B	B	B	B	B	B	B	B	B	B	B
DN 15	B	B	B	B	B	B	B	B	B	B	B	B
DN 20	B	B	B	B	B	B	B	B	B	B	B	B
DN 25	B	B	B	B	B	B	B	B	B	B	B	B
DN 32	B	B	B	B	B	B	B	B	B	B	C	C
DN 40	B	B	B	B	B	B	B	B	C	C	C	C
DN 50	B	B	B	B	B	C	C	C	C	C	C	C
DN 65	B	B	B	C	C	C	C	C	C	C	-	-
DN 80	B	B	C	C	C	C	-	-	-	-	-	-
DN 100	B	C	C	-	-	-	-	-	-	-	-	-
DN 150	-	-	-	-	-	-	-	-	-	-	-	-



Code in Table	Part No.	Actuator
B	27522.35B6.6GPS	
C	27522.60A6.6GPS	

Materials	DIN EN	ASTM
1 Body	1.4571	A 240 Grade 316Ti
2 Body	1.4571	A 240 Grade 316Ti
3 Diaphragm	EPDM	
4 Springs	1.7102	AISI 9254
5 Actuator stem	1.4404	A 276 Grade 316L
6 Coupling	1.4571	A 240 Grade 316Ti

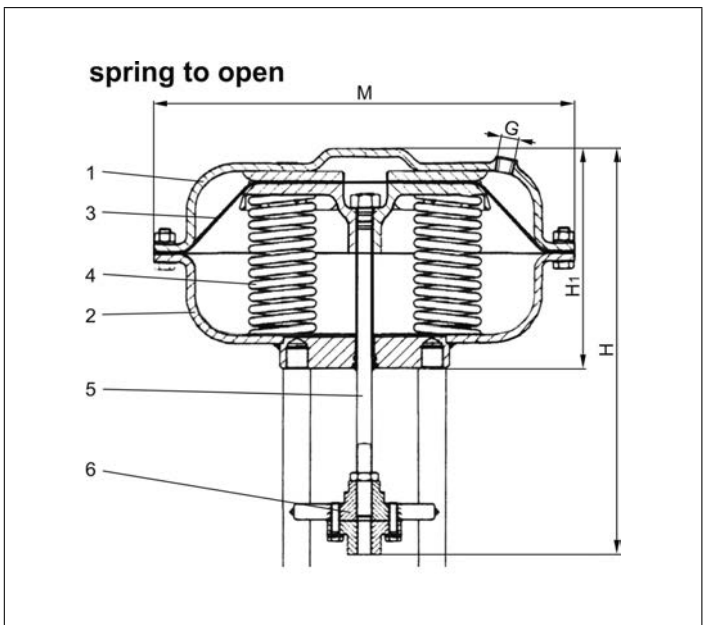

Type 27522	Technical data		
Part No. Actuator	27522		
	.35B6.6GPS	.60A6.6GPS	
Diameter Actuator	M	210	310
Height	H	276	309
Height	H1	136	166
Thread	G	1/4" NPT	1/4" NPT
Diaphragm area	cm ²	280	530
Spring rage	bar	0.8 - 3.0	0.8 - 2.8
Regulating lift	mm	35	40
Weight	ca. kg	5.0	12.5

Dimensions in mm.

Pneumatic Actuators for Control Valves

Actuator - **spring to open**, air to close

maximum air pressure for operation 6.0 bar g

"cleaned and degreased for oxygen service"

Available options - on request only:

- Pneumatic actuator with override handwheel

Ambient temperature limit: -40°C / -40°F (233K) up to +80°C / 176°F (353K)



Overview - required actuator sizes for differential pressures

Valve size	Differential pressure in bar									
	0	5.1	13.1	15.1	21.1	23.1	29.1	34.1	37.1	
	5.0	13.0	15.0	21.0	23.0	29.0	34.0	37.0	50.0	
DN 10	B	B	B	B	B	B	B	B	B	B
DN 15	B	B	B	B	B	B	B	B	B	B
DN 20	B	B	B	B	B	B	B	B	B	B
DN 25	B	B	B	B	B	B	B	B	B	B
DN 32	B	B	B	B	B	B	B	B	B	C
DN 40	B	B	B	B	B	B	B	C	C	C
DN 50	C	C	C	C	C	C	C	C	C	C
DN 65	C	C	C	C	C	C	-	-	-	-
DN 80	C	C	C	C	-	-	-	-	-	-
DN 100	C	C	-	-	-	-	-	-	-	-
DN 150	-	-	-	-	-	-	-	-	-	-

Code in Table	Part No.	Actuator
B	27522.35B6.6GPS	
C	27522.60A6.6GPS	

Materials	DIN EN	ASTM
1 Body	1.4571	A 240 Grade 316Ti
2 Body	1.4571	A 240 Grade 316Ti
3 Diaphragm	EPDM	
4 Springs	1.7102	AISI 9254
5 Actuator stem	1.4404	A 276 Grade 316L
6 Coupling	1.4571	A 240 Grade 316Ti

Type 27522	Technical data		
Part No. Actuator	27522		
	.35B6.6GPS	.60A6.6GPS	
Diameter Actuator	M	210	310
Height	H	276	309
Height	H1	136	166
Thread	G	1/4" NPT	1/4" NPT
Diaphragm area	cm ²	280	530
Spring rage	bar	0.8 - 3.0	0.8 - 2.8
Regulating lift	mm	35	40
Weight	ca. kg	5.0	12.5

Dimensions in mm.

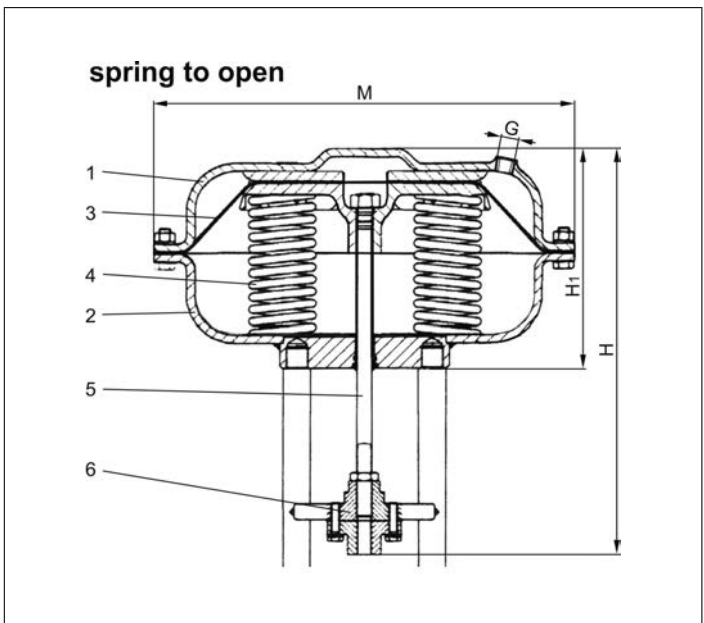

Offshore Valves

Type 05714 - Check Valve



Cryogenic-Check Valves, PN50 (DN100=PN40)

Stainless steel body and cap
with spring, opening pressure ca. 0.1 bar
"cleaned and degreased for oxygen service"

Part No. 05714.X.004*

Butt or Socket weld connection for stainless steel pipes acc. to ISO 1127 or ASTM A312
Disc seal: PTFE / Carbon filled (25%)

Part No. 05714.X.005*

Butt or Socket weld connection for stainless steel pipes acc. to ISO 1127 or ASTM A312
Disc seal: PTFE

Available options - on request only:

- Welded stainless steel stubs acc. to ISO 1127 or ASTM A312 - length FF + 200mm



Applications:

Suitable for hydrogen, approved for air gases, vapours and cryogenic liquefied gases incl. LNG.
Working temperature: -255°C / -427°F (18K) up to +120°C / +248°F (393K)

Materials	DIN EN	ASTM
1 Body	1.4409	A 351 CF3M
2 Valve seal up to DN50	PTFE / Carbon filled (25%)	
2 Valve seal from DN65	PTFE	
3 Disc	1.4404	A 276 Grade 316L
4 Spring	1.4571	A 313 Grade 316Ti
5 Bonnet gasket	Graphite	
6 Bolts	1.4571/A4 similar A 194 B8T	
7 Cap	1.4404	A 276 Grade 316L

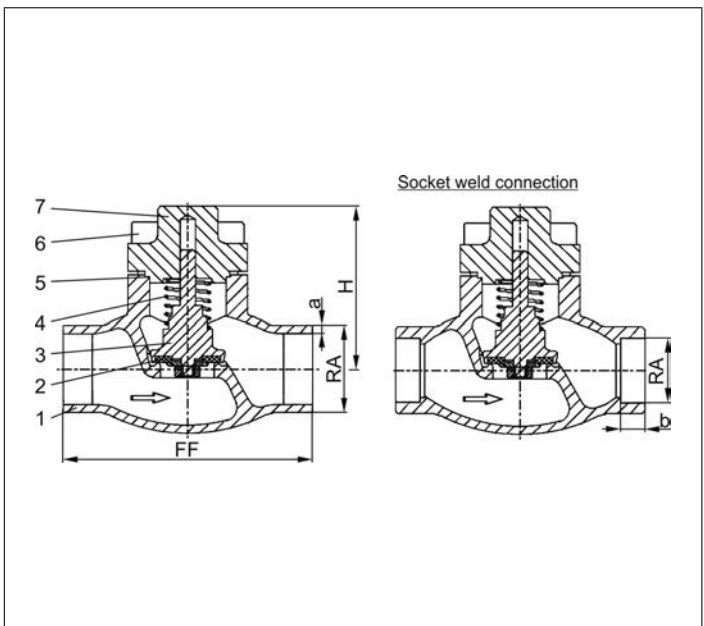

Standard marking acc. to Pressure Equipment Directive 97/23/EC (PED).



Type 05714 - Standard	Technical data														
	DN	10	15	15	20	25	32	40	40	50	65	80	100	150	
Nominal size	.X.	1012	1517	1521	2026	2533	3238	4042	4048	5060	657x	8088	0114	0168	
Dimension code	.X.	1012	1517	1521	2026	2533	3238	4042	4048	5060	657x	8088	0114	0168	
Face-to-face dimension	FF	70	85	85	100	115	115	130	130	155	205	245	280	400	
Height	H	71	71	71	72	75	87	95	95	95	125	150	185	214	
Outside pipe-Ø ISO 1127	RA	12.0	17.2	21.3	26.9	33.7	38.0	42.4	48.3	60.3	76.1	88.9	114.3	168.3	
Wall thickness pipe ISO 1127	a	1.0	1.6	2.0	2.0	2.0	2.0	2.0	2.0	2.0	2.6	3.2	6.0	7.1	
Outside pipe-Ø ASTM A312	RA	13.72	17.15	21.34	26.67	33.40	-	42.16	48.26	60.33	73.03	88.90	114.30	168.30	
Wall thickness pipe ASTM A312	a	dimensions acc. to S10 or S40													
Socket depth	b	6	10	10	13	13	-	13	13	16	16	16	20	20	
Weight	ca. kg	0.7	0.95	1.0	1.3	1.6	2.4	3.9	3.9	5.7	9.6	14.6	20.0	50.0	
Kvs-Value	m ³ /h	1.6	3.8	4.3	6.7	11.5	14.0	20.6	22.6	37.1	71.1	104.0	170.0	350.0	
Cv-Value	gal/mir	1.9	4.4	5.0	7.8	13.4	16.2	23.9	26.3	43.2	82.7	120.9	195.2	401.8	

Dimensions in mm. Compliance of tightness requirements acc. to EN 1626 for DN150 up to 20 bar differential pressure. In the range of >20-40 bar, 350-700ml (1 bar, 20°C [68°F]) are reached.

Offshore Valves

Type 05717 - Check Valve



Cryogenic-Check Valves, PN50

Stainless steel body and cap
with spring, opening pressure ca. 0.1 bar
"cleaned and degreased for oxygen service"

Part No. 05717.X.0001

Female thread connection (G) acc. to ISO 228/1

Part No. 05717.X.0006

Female thread connection NPT acc. to ANSI B 1.20.1

Available options - on request only:

- Female thread connection (R) acc. to ISO 7-Rc



Applications:

Suitable for hydrogen, approved for air gases, vapours and cryogenic liquefied gases incl. LNG.

Working temperature: -255°C / -427°F (18K) up to +120°C / +248°F (393K)

Materials	DIN EN	ASTM
1 Body	1.4409	A 351 CF3M
2 Valve seal up to DN50	PTFE / Carbon filled (25%)	
2 Valve seal from DN65	PTFE	
3 Disc	1.4404	A 276 Grade 316L
4 Spring	1.4571	A 313 Grade 316Ti
5 Bonnet gasket	Graphite	
6 Bolts	1.4571/A4	similar A 194 B8T
7 Cap	1.4404	A 276 Grade 316L

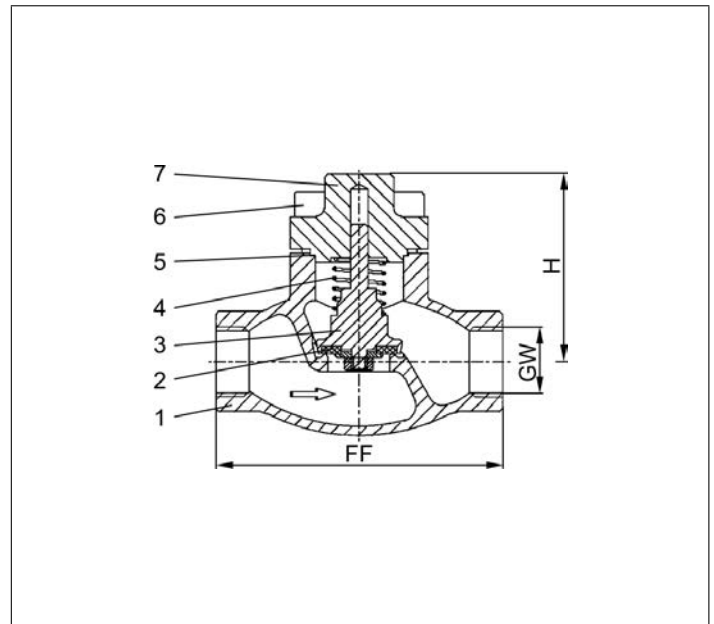

Standard marking acc. to Pressure Equipment Directive 97/23/EC (PED).



Type 05717 - Standard design	Technical data								
Nominal size	DN	10	10	15	20	25	40	40	50
Thread size	GW	1/4	3/8	1/2	3/4	1	1-1/4	1-1/2	2
Dimension code	.X.	0200	0300	0400	0600	1000	1200	1400	2000
Face-to-face dimension	FF	70	70	85	100	115	130	130	155
Height	H	71	71	71	72	75	95	95	95
Weight	ca. kg	0.7	0.7	1.0	1.3	1.6	3.9	3.9	5.7
Kvs-Value	m ³ /h	1.6	2.2	4.3	6.7	11.5	20.6	22.6	37.1
Cv-Value	gal/min	1.9	2.6	5.0	7.8	13.4	23.9	26.3	43.2

Dimensions in mm.

Offshore Valves

Type 05719 - Check Valve, DIN EN Flanges



Cryogenic-Check Valves, PN40

Stainless steel body and cap
with spring, opening pressure ca. 0.1 bar
"cleaned and degreased for oxygen service"

Part No. 05719.X.0002

Flanged connection acc. to DIN EN 1092-1 PN40

Available options - on request only:

- Nominal sizes DN15, DN20 and DN150 with welded flange



Applications:

Approved for air gases, vapours and cryogenic liquefied gases incl. LNG.

Working temperature: -255°C / -427°F (18K) up to +120°C / +248°F (393K)

Materials	DIN EN	ASTM
1 Body	1.4409	A 351 CF3M
2 Valve seal up to DN50	PTFE / Carbon filled (25%)	
2a Valve seal from DN65	PTFE	
3 Disc	1.4404	A 276 Grade 316L
4 Spring	1.4571	A 313 Grade 316Ti
5 Bonnet gasket	Graphite	
6 Bolts	1.4571/A4	ähnlich A 194 B8T
7 Cap	1.4404	A 276 Grade 316L

Standard marking acc. to Pressure Equipment Directive 97/23/EC (PED).

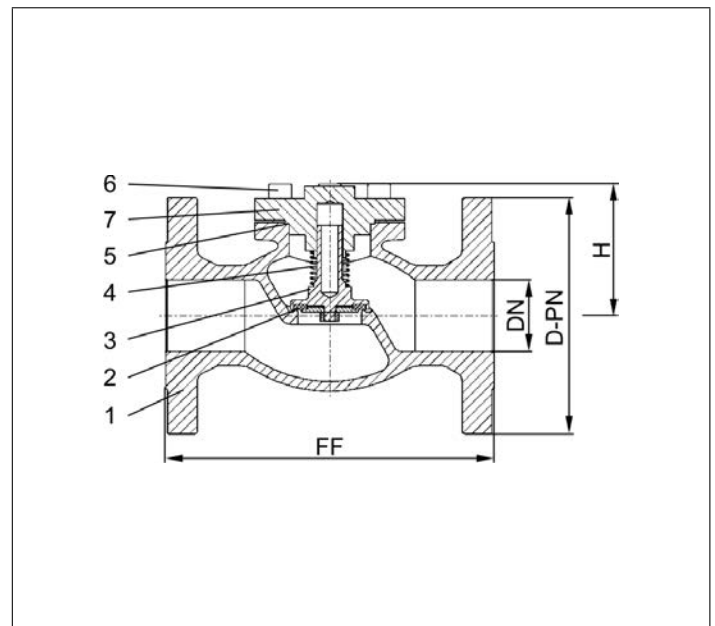

Type 05719 - Standard design	Technical data						
Nominal size	DN	25	40	50	65	80	100
Dimension code - Flange EN 1092-1 PN40	.X.	0250	0400	0500	0650	0800	1000
Flange-Ø	D-PN	115	150	165	185	200	235
Face-to-face dimension	FF	160	200	230	290	310	350
Height	H	75	95	90	125	150	165
Weight	ca. kg	4.4	6.4	11.6	19.2	25.2	39.8
Kvs-Value	m ³ /h	11.5	22.6	37.1	71.1	104.0	170.0
Cv-Value	gal/min	13.4	26.3	43.2	82.7	120.9	195.2

Dimensions in mm.

Offshore Valves

Type 05719 - Check Valve, ANSI Flanges



Cryogenic-Check Valves, class 300

Stainless steel body and cap
with spring, opening pressure ca. 0.1 bar
"cleaned and degreased for oxygen service"

Part No. 05719.X.0003

Flanged connection acc. to ANSI B16.5 class 300

Available options - on request only:

- Nominal sizes DN15, DN20 and DN150 with welded flange



Applications:

Approved for air gases, vapours and cryogenic liquefied gases incl. LNG.

Working temperature: -255°C / -427°F (18K) up to +120°C / +248°F (393K)

Materials	DIN EN	ASTM
1 Body	1.4409	A 351 CF3M
2 Valve seal up to DN50	PTFE / Carbon filled (25%)	
2a Valve seal from DN65	PTFE	
3 Disc	1.4404	A 276 Grade 316L
4 Spring	1.4571	A 313 Grade 316Ti
5 Bonnet gasket	Graphite	
6 Bolts	1.4571/A4	ähnlich A 194 B8T
7 Cap	1.4404	A 276 Grade 316L

Standard marking acc. to Pressure Equipment Directive 97/23/EC (PED).

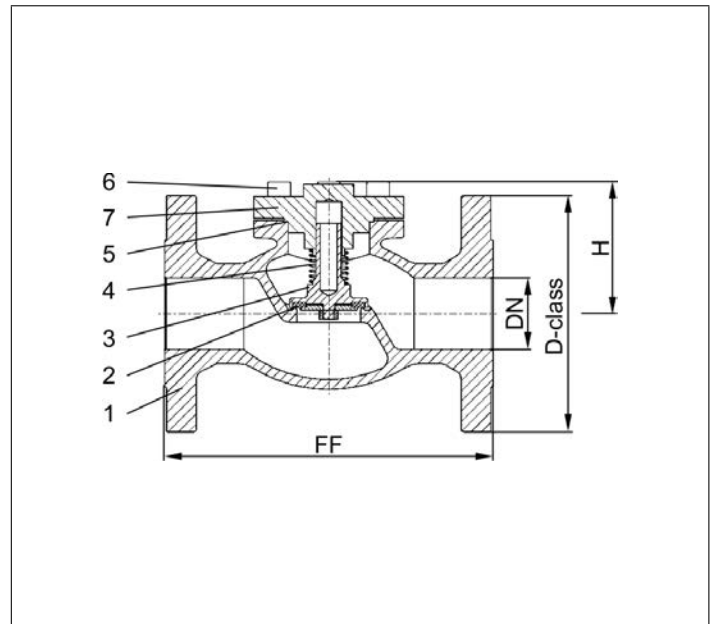

Type 05719 - Standard design	Technical data						
Nominal size	DN	25	40	50	65	80	100
Dimension code - Flange ANSI B16.5 class 300	.X.	1000	1400	2000	2400	3000	4000
Flange-Ø	D-class	123.9	155.4	165	190.5	209.5	254
Face-to-face dimension	FF	160	200	230	290	310	350
Height	H	75	95	90	125	150	165
Weight	ca. kg	4.4	6.4	11.6	19.2	25.2	39.8
Kvs-Value	m ³ /h	11.5	22.6	37.1	71.1	104.0	170.0
Cv-Value	gal/min	13.4	26.3	43.2	82.7	120.9	195.2

Dimensions in mm.

Offshore Valves

Type 08717 - Strainer



Cryogenic-Strainer, PN50 (DN100=PN40)

Stainless steel body and cap
with strainer screen mesh size 0.25 mm
"cleaned and degreased for oxygen service"

Part No. 08717.X.000*

* Butt weld connection for stainless steel pipes acc. to ISO 1127 or ASTM A312

Part No. 08717.X.0004

Socket weld connection for stainless steel pipes acc. to ISO 1127 or ASTM A312

Available options - on request only:

- Welded stainless steel stubs acc. to ISO 1127 or ASTM A312 - length FF + 200mm
- other mesh sizes for strainer screen (changed flow coefficient)
- strainer screen in bronze or monel
- sintered filter in bronze or stainless steel in various porosities



Applications:

Suitable for hydrogen, approved for air gases, vapours and cryogenic liquefied gases incl. LNG.

Working temperature: -255°C / -427°F (18K) up to +120°C / +248°F (393K)

Materials	DIN EN	ASTM
1 Body	1.4409	A 351 CF3M
2 Strainer screen	1.4404	A 276 Grade 316L
3 Bonnet gasket	Graphite	
4 Bolts	1.4571/A4 similar A 194 B8T	
5 Cap	1.4404	A 276 Grade 316L

Standard marking acc. to Pressure Equipment Directive 97/23/EC (PED).

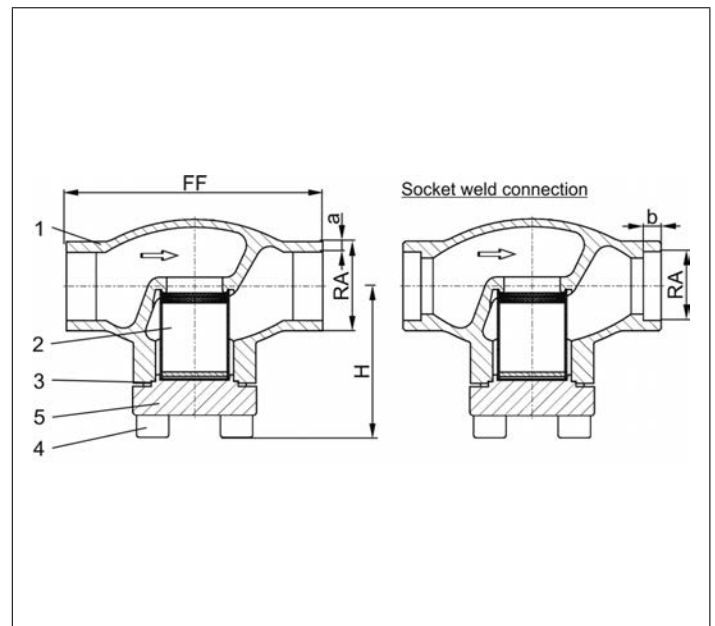

Type 08717 - Standard	Technical data												
	DN	10	15	15	20	25	32	40	40	50	65	80	100
Nominal size	.X.	1012	1517	1521	2026	2533	3238	4042	4048	5060	657x	8088	0114
Dimension code	FF	70	85	85	100	115	115	130	130	155	205	245	280
Face-to-face dimension	H	62	62	62	65	69	76	89	89	89	125	150	166
Height	RA	12.0	17.2	21.3	26.9	33.7	38.0	42.4	48.3	60.3	76.1	88.9	114.3
Outside pipe-Ø ISO 1127	a	1.0	1.6	2.0	2.0	2.0	2.0	2.0	2.0	2.0	2.6	3.2	6.0
Wall thickness pipe ISO 1127	RA	13.72	17.15	21.34	26.67	33.40	-	42.16	48.26	60.33	73.03	88.90	114.3
Outside pipe-Ø ASTM A312	a	dimensions acc. to S10 or S40											
Wall thickness pipe ASTM A312	b	6	10	10	13	13	-	13	13	16	16	16	20
Socket depth	ca. kg	0.6	0.75	0.8	0.9	1.2	1.8	3.1	3.1	4.7	8.9	13.6	18.0
Weight	m ³ /h	1.5	3.4	3.4	6.5	9.5	14.0	19.0	21.0	28.0	62.0	90.0	118.0
Kvs-Value	gal/mir	1.7	3.9	3.9	7.5	11.0	16.2	22.0	24.3	32.4	71.7	104.0	136.4
Cv-Value													

Dimensions in mm.

Offshore Valves

Type 08716 - Strainer



Cryogenic-Strainer, PN50

Stainless steel body and cap
with strainer screen mesh size 0.25 mm
"cleaned and degreased for oxygen service"

Part No. 08716.X.0001

Female thread connection (G) acc. to ISO 228/1

Part No. 08716.X.0006

Female thread connection NPT acc. to ANSI B 1.20.1

Available options - on request only:

- Female thread connection (R) acc. to ISO 7-Rc
- other mesh sizes for strainer screen (changed flow coefficient)
- strainer screen in bronze or monel
- sintered filter in bronze or stainless steel in various porosities



Applications:

Suitable for hydrogen, approved for air gases, vapours and cryogenic liquefied gases incl. LNG.

Working temperature: -255°C / -427°F (18K) up to +120°C / +248°F (393K)

Materials	DIN EN	ASTM
1 Body	1.4409	A 351 CF3M
2 Strainer screen	1.4404	A 276 Grade 316L
3 Bonnet gasket	Graphite	
4 Bolts	1.4571/A4 similar A 194 B8T	
5 Cap	1.4404	A 276 Grade 316L

Standard marking acc. to Pressure Equipment Directive 97/23/EC (PED).

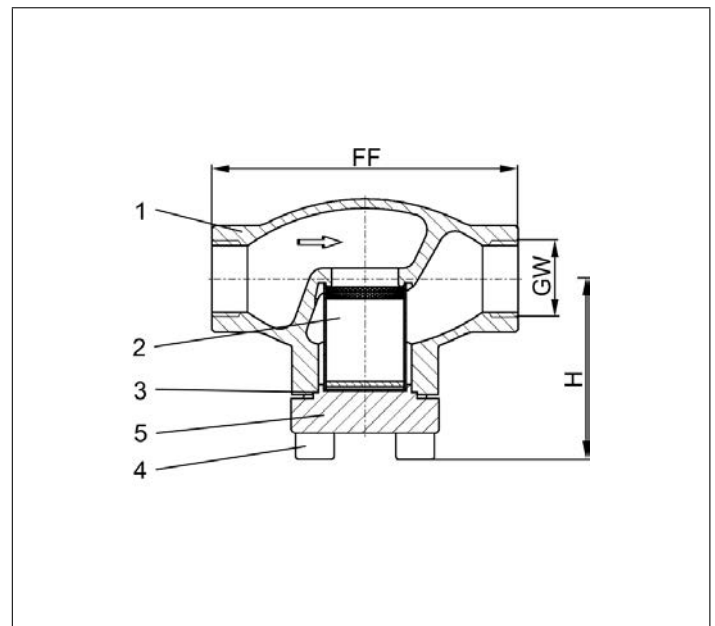

Type 08716 - Standard design	Technical data								
Nominal size	DN	10	10	15	20	25	40	40	50
Thread size	GW	1/4	3/8	1/2	3/4	1	1-1/4	1-1/2	2
Dimension code	.X.	0200	0300	0400	0600	1000	1200	1400	2000
Face-to-face dimension	FF	70	70	85	100	115	130	130	155
Height	H	62	62	62	65	69	89	89	89
Weight	ca. kg	0.6	0.6	0.8	0.9	1.2	3.1	3.1	4.7
Kvs-Value	m ³ /h	1.5	1.5	3.4	6.5	9.5	19.0	21.0	28.0
Cv-Value	gal/min	1.7	1.7	3.9	7.5	11.0	22.0	24.3	32.4

Dimensions in mm.

Fire Safe and Offshore Valves

Type 01851 - Globe Valve



Cryogenic-Globe and Globe/Check Valves, PN50 (DN100=PN40)
"Fire safe" type test approval acc. to EN ISO 10497

Stainless steel body and topwork,
 "live loaded" gland packing
 "cleaned and degreased for oxygen service"

Part No. 01851.X.000*

Part No. 01851.X.500* Globe/Check Valve

* Butt weld connection for stainless steel pipes acc. to ISO 1127 or ASTM A312

Part No. 01851.X.0004

Part No. 01851.X.5004 Globe/Check Valve

Socket weld connection for stainless steel pipes acc. to ISO 1127 or ASTM A312

Available options - on request only:

- Welded stainless steel stubs acc. to ISO 1127 or ASTM A312 - length FF + 200mm
- Valve with control disc (tapered design)



Applications:

Suitable for hydrogen, approved for air gases, vapours and cryogenic liquefied gases incl. LNG.

Working temperature: -255°C / -427°F (18K) up to +120°C / +248°F (393K)

Recommended working temperature: -60°C / -76°F (213K) up to +120°C / +248°F (393K)

Materials	DIN EN	ASTM
1 Body	1.4409	A 351 CF3M
2 Valve seal	PTFE / Carbon filled (25%)	
3 Disc	1.4404	A 276 Grade 316L
4 Bonnet gasket	Graphite	
5 Headpiece	1.4404	A 276 Grade 316L
6 Bolts	1.4571/A4	similar A 194 B8T
8 Stem	1.4404	A 276 Grade 316L
9 Gland packing	Graphite / PTFE / MICA	
10 Gland nut	1.4305	A 276 Grade 303
11 Handwheel	1.4409	SA 351 CF3M
12 Spring	1.4571	A 313 Grade 316Ti
13 Bush	CW452K	B 159 UNS C51900

Standard marking acc. to Pressure Equipment Directive 97/23/EC (PED).

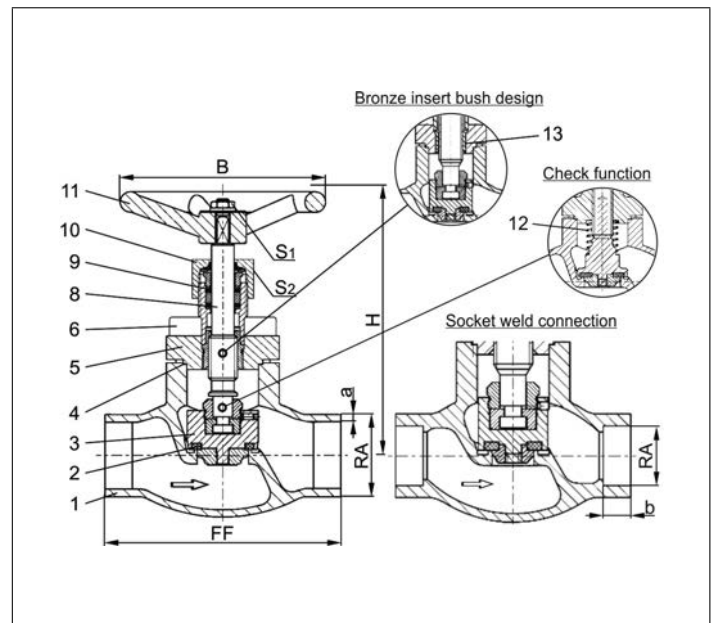

Type 01851 - Standard design	Technical data												
	DN	10	15	15	20	25	32	40	40	50	65	80	100
Nominal size	.X.	1012	1517	1521	2026	2533	3238	4042	4048	5060	657x	8088	0114
Dimension code	.X.	1012	1517	1521	2026	2533	3238	4042	4048	5060	657x	8088	0114
Face-to-face dimension	FF	70	85	85	100	115	115	130	130	155	205	245	280
Height	H	140	140	140	140	140	170	175	175	200	260	310	350
Outside pipe-Ø ISO 1127	RA	12.0	17.2	21.3	26.9	33.7	38.0	42.4	48.3	60.3	76.1	88.9	114.3
Wall thickness pipe ISO 1127	a	1.0	1.6	2.0	2.0	2.0	2.0	2.0	2.0	2.0	2.6	3.2	6.0
Outside pipe-Ø ASTM A312	RA	13.72	17.15	21.34	26.67	33.40	-	42.16	48.26	60.33	73.03	88.90	114.3
Wall thickness pipe ASTM A312	a	dimensions acc. to S10 or S40											
Socket depth	b	6	10	10	13	13	-	13	13	16	16	16	20
Handwheel-Ø	B	100	100	100	100	100	125	125	125	125	200	250	315
Wrench size across flats	S ₁	10	10	10	10	10	13	13	13	13	13	13	13
Wrench size across flats	S ₂	30	30	30	30	30	36	36	36	36	36	36	41
Weight	ca. kg	1.0	1.25	1.3	1.7	2.0	2.8	4.2	4.2	6.7	10.7	16.0	23.0
Kvs-Value	m ³ /h	1.6	3.8	4.3	6.7	11.5	14.0	20.6	22.6	37.1	71.1	104.0	170.0
Cv-Value	gal/min	1.9	4.4	5.0	7.8	13.4	16.2	23.9	26.3	43.2	82.7	120.9	195.2

Dimensions in mm.

Fire Safe and Offshore Valves

Type 01855 - Globe Valve



Cryogenic-Globe and Globe/Check Valves, PN50
"Fire safe" type test approval acc. to EN ISO 10497

Stainless steel body and topwork,
 "live loaded" gland packing
 "cleaned and degreased for oxygen service"

Part No. 01855.X.0001

Part No. 01855.X.5001 Globe/Check Valve

Female thread connection (G) acc. to ISO 228/1

Part No. 01855.X.0006

Part No. 01855.X.5006 Globe/Check Valve

Female thread connection NPT acc. to ANSI B 1.20.1

Available options - on request only:

- Female thread connection (R) acc. to ISO 7-Rc
- Valve with control disc (tapered design)



Applications:

Suitable for hydrogen, approved for air gases, vapours and cryogenic liquefied gases incl. LNG.

Working temperature: -255°C / -427°F (18K) up to +120°C / +248°F (393K)

Recommended working temperature: -60°C / -76°F (213K) up to +120°C / +248°F (393K)

Materials	DIN EN	ASTM
1 Body	1.4409	A 351 CF3M
2 Valve seal	PTFE / Carbon filled (25%)	
3 Disc	1.4404	A 276 Grade 316L
4 Bonnet gasket	Graphite	
5 Headpiece	1.4404	A 276 Grade 316L
6 Bolts	1.4571/A4	similar A 194 B8T
8 Stem	1.4404	A 276 Grade 316L
9 Gland packing	Graphite / PTFE / MICA	
10 Gland nut	1.4305	A 276 Grade 303
11 Handwheel	1.4409	SA 351 CF3M
12 Spring	1.4571	A 313 Grade 316Ti
13 Bush	CW452K	B 159 UNS C51900

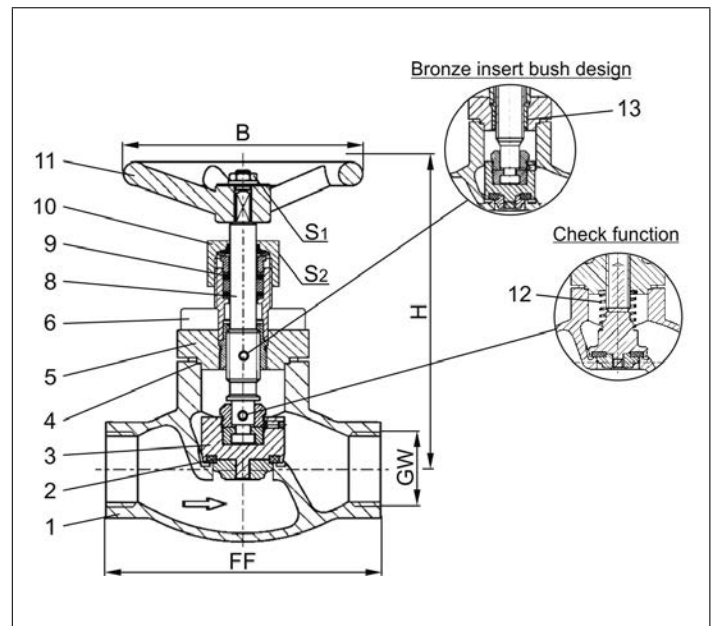

Standard marking acc. to Pressure Equipment Directive 97/23/EC (PED).



Type 01855 - Standard design	Technical data								
Nominal size	DN	10	10	15	20	25	40	40	50
Thread size	GW	1/4	3/8	1/2	3/4	1	1-1/4	1-1/2	2
Dimension code	.X.	0200	0300	0400	0600	1000	1200	1400	2000
Face-to-face dimension	FF	70	70	85	100	115	130	130	155
Height	H	140	140	140	140	140	175	175	200
Handwheel-Ø	B	100	100	100	100	100	125	125	125
Wrench size across flats	S ₁	10	10	10	10	10	13	13	13
Wrench size across flats	S ₂	30	30	30	30	30	36	36	36
Weight	ca. kg	1.0	1.0	1.3	1.7	2.0	4.2	4.2	6.7
Kvs-Value	m ³ /h	1.6	2.2	4.3	6.7	11.5	20.6	22.6	37.1
Cv-Value	gal/min	1.9	2.6	5.0	7.8	13.4	23.9	26.3	43.2

Dimensions in mm.

Fire Safe and Offshore Valves

Type 03851 - Globe valve



Cryogenic-Globe and Globe/Check Valves, PN40
"Fire safe" type test approval acc. to EN ISO 10497

Stainless steel body and topwork,
 "live loaded" gland packing
 "cleaned and degreased for oxygen service"

Part No. 03851.X.0002

Part No. 03851.X.5002 Globe/Check Valve

Flanged connection acc. to DIN EN 1092-1 PN40

Available options - on request only:

- Valve with control disc (tapered design)
- Nominal sizes DN15, DN20 and DN150 with welded flange



Applications:

Suitable for hydrogen, approved for air gases, vapours and cryogenic liquefied gases incl. LNG.

Working temperature: -255°C / -427°F (18K) up to +120°C / +248°F (393K)

Recommended working temperature: -60°C / -76°F (213K) up to +120°C / +248°F (393K)

Materials	DIN EN	ASTM
1 Body	1.4409	A 351 CF3M
2 Valve seal	PTFE / Carbon filled (25%)	
3 Disc	1.4404	A 276 Grade 316L
4 Bonnet gasket	Graphite	
5 Headpiece	1.4404	A 276 Grade 316L
6 Bolts	1.4571/A4	ähnlich A 194 B8T
8 Stem	1.4404	A 276 Grade 316L
9 Gland packing	Graphite / PTFE / MICA	
10 Gland nut	1.4404	A 276 Grade 316L
11 Handwheel	1.4409	SA 351 CF3M
12 Spring	1.4571	A 313 Grade 316Ti
13 Bush	CW452K	B 159 UNS C51900

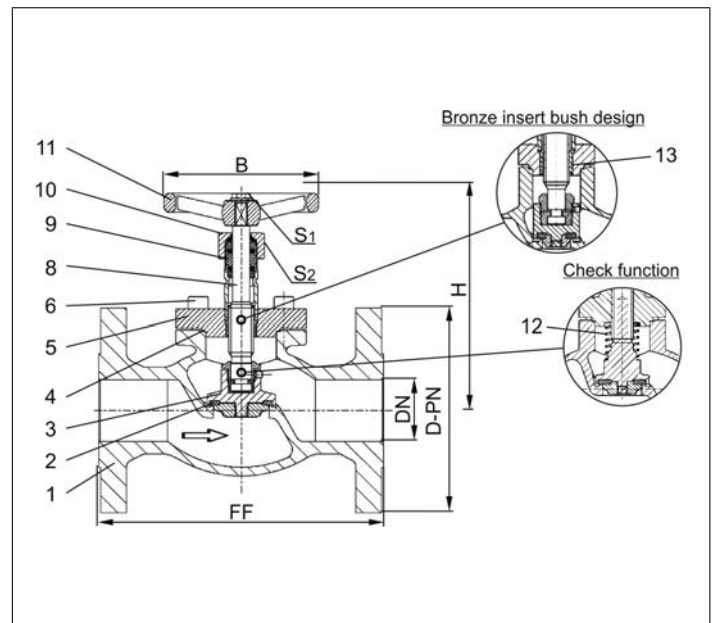

Standard marking acc. to Pressure Equipment Directive 97/23/EC (PED).



Typ 03851 - Standard design	Technical data						
Nominal size	DN	25	40	50	65	80	100
Dimension code - Flange EN 1092-1 PN40	.X.	0250	0400	0500	0650	0800	1000
Flange-Ø	D-PN	115	150	165	185	200	235
Face-to-face dimension	FF	160	200	230	290	310	350
Height	H	140	170	200	260	310	350
Handwheel-Ø	B	100	125	125	200	250	315
Wrench size across flats	S ₁	10	13	13	13	13	13
Wrench size across flats	S ₂	30	36	36	36	36	41
Weight	ca. kg	4.5	9.1	12.9	20.6	27.6	42.0
Kvs-Value	m ³ /h	11.5	22.6	37.1	71.1	104.0	170.0
Cv-Value	gal/min	13.4	26.3	43.2	82.7	120.9	195.2

Abmessungen in mm.

Fire Safe and Offshore Valves

Type 03851 - Globe valve



Cryogenic-Globe and Globe/Check Valves, class 300
"Fire safe" type test approval acc. to EN ISO 10497

Stainless steel body and topwork,
 "live loaded" gland packing
 "cleaned and degreased for oxygen service"

Part No. 03851.X.0003

Part No. 03851.X.5003 Globe/Check Valve

Flanged connection acc. to DIN EN 1092-1 PN40

Available options - on request only:

- Valve with control disc (tapered design)
- Nominal sizes DN15, DN20 and DN150 with welded flange



Applications:

Suitable for hydrogen, approved for air gases, vapours and cryogenic liquefied gases incl. LNG.

Working temperature: -255°C / -427°F (18K) up to +120°C / +248°F (393K)

Recommended working temperature: -60°C / -76°F (213K) up to +120°C / +248°F (393K)

Materials	DIN EN	ASTM
1 Body	1.4409	A 351 CF3M
2 Valve seal	PTFE / Carbon filled (25%)	
3 Disc	1.4404	A 276 Grade 316L
4 Bonnet gasket	Graphite	
5 Headpiece	1.4404	A 276 Grade 316L
6 Bolts	1.4571/A4	ähnlich A 194 B8T
8 Stem	1.4404	A 276 Grade 316L
9 Gland packing	Graphite / PTFE / MICA	
10 Gland nut	1.4404	A 276 Grade 316L
11 Handwheel	1.4409	SA 351 CF3M
12 Spring	1.4571	A 313 Grade 316Ti
13 Bush	CW452K	B 159 UNS C51900

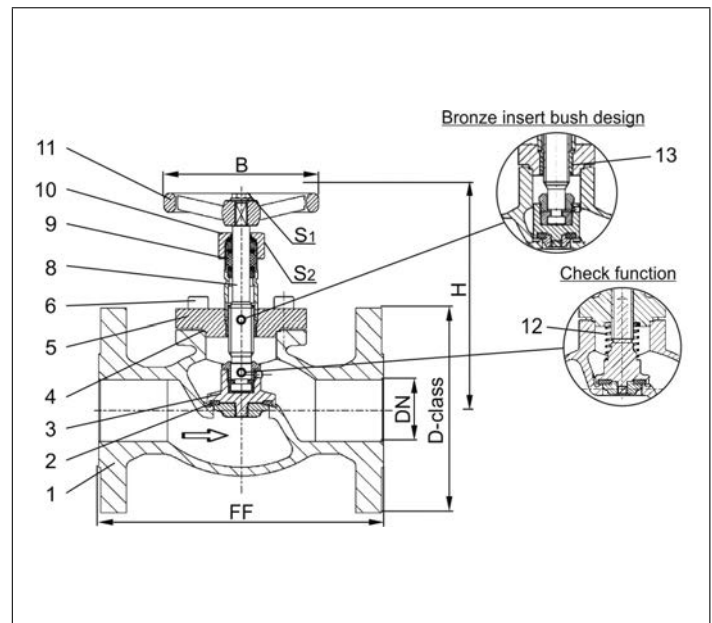

Standard marking acc. to Pressure Equipment Directive 97/23/EC (PED).



Type 03851 - Standard design	Technical data						
	DN	25	40	50	65	80	100
Nominal size	.X.	1000	1400	2000	2400	3000	4000
Dimension code - Flange ANSI B16.5 class 300	D-class	123.9	155.4	165	190.5	209.5	254
Flange-Ø	FF	160	200	230	290	310	350
Face-to-face dimension	H	140	170	200	260	310	350
Height	B	100	125	125	200	250	315
Handwheel-Ø	S ₁	10	13	13	13	13	13
Wrench size across flats	S ₂	30	36	36	36	36	41
Weight	ca. kg	4.5	9.1	12.9	20.6	27.6	42.0
Kvs-Value	m ³ /h	11.5	22.6	37.1	71.1	104.0	170.0
Cv-Value	gal/min	13.4	26.3	43.2	82.7	120.9	195.2

Dimensions in mm.

Fire Safe and Offshore Valves

Type 01841 - Globe Valve



Cryogenic-Globe and Globe/Check Valves, PN50 (DN100/150=PN40)
“Fire safe” type test approval acc. to EN ISO 10497

Stainless steel body and topwork,
 “live loaded” gland packing
 “cleaned and degreased for oxygen service”

- Part No. 01841.X.001* (H = 270mm)**
- Part No. 01841.X.002* (H = 370mm)**
- Part No. 01841.X.501* (H = 270mm) Globe/Check Valve**
- Part No. 01841.X.502* (H = 370mm) Globe/Check Valve**

* Butt weld connection for stainless steel pipes acc. to ISO 1127 or ASTM A312

- Part No. 01841.X.0014 (H = 270mm)**
- Part No. 01841.X.0024 (H = 370mm)**
- Part No. 01841.X.5014 (H = 270mm) Globe/Check Valve**
- Part No. 01841.X.5024 (H = 370mm) Globe/Check Valve**

Socket weld connection for stainless steel pipes acc. to ISO 1127 or ASTM A312

Available options - on request only:

- Extension H up to 900mm
- Valve with control disc (tapered design)

Applications:

Suitable for hydrogen, approved for air gases, vapours and cryogenic liquefied gases incl. LNG.

Working temperature: -255°C / -427°F (18K) up to +120°C / +248°F (393K)



Materials	DIN EN	ASTM
1 Body	1.4409	A 351 CF3M
2 Valve seal	PTFE / Carbon filled (25%)	
3 Disc	1.4404	A 276 Grade 316L
4 Bonnet gasket	Graphite	
5 Headpiece	1.4404	A 276 Grade 316L
6 Bolts	1.4571/A4	similar A 194 B8T
7 Elongation tube	1.4571	A 213 TP 316Ti
8 Stem	1.4404	A 276 Grade 316L
9 Gland packing	Graphite / PTFE / MICA	
10 Gland nut	1.4305	A 276 Grade 303
11 Handwheel	1.4409	A 351 CF3M
12 Spring	1.4571	A 313 Grade 316Ti
13 Bush	CW452K	B 159 UNS C51900

Standard marking acc. to Pressure Equipment Directive 97/23/EC (PED).

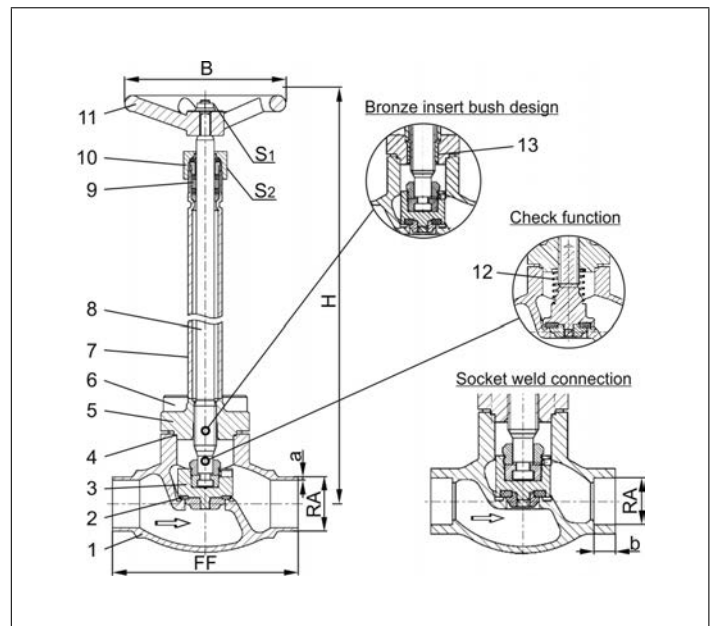

Type 01841 - Standard	Technical data													
	DN	10	15	15	20	25	32	40	40	50	65	80	100	150
Nominal size	.X.	1012	1517	1521	2026	2533	3238	4042	4048	5060	657x	8088	0114	0168
Dimension code	.X.	1012	1517	1521	2026	2533	3238	4042	4048	5060	657x	8088	0114	0168
Face-to-face dimension	FF	70	85	85	100	115	115	130	130	155	205	245	280	400
Height	H	270 mm or 370 mm												
Outside pipe-Ø ISO 1127	RA	12.0	17.2	21.3	26.9	33.7	38.0	42.4	48.3	60.3	76.1	88.9	114.3	168.3
Wall thickness pipe ISO 1127	a	1.0	1.6	2.0	2.0	2.0	2.0	2.0	2.0	2.0	2.6	3.2	6.0	7.1
Outside pipe-Ø ASTM A312	RA	13.72	17.15	21.34	26.67	33.40	-	42.16	48.26	60.33	73.03	88.90	114.3	168.3
Wall thickness pipe ASTM A312	a	dimensions acc. to S10 or S40												
Socket depth	b	6	10	10	13	13	-	13	13	16	16	16	20	20
Handwheel-Ø	B	100	100	100	100	100	125	125	125	125	200	250	315	360
Wrench size across flats	S ₁	10	10	10	10	10	13	13	13	13	13	13	13	19
Wrench size across flats	S ₂	30	30	30	30	30	36	36	36	36	36	36	41	41
Weight	ca. kg	1.4	1.65	1.7	2.1	2.4	3.3	4.7	4.7	7.2	12.7	17.0	24.5	54.0
Kvs-Value	m ³ /h	1.6	3.8	4.3	6.7	11.5	14.0	20.6	22.6	37.1	71.1	104.0	170.0	350.0
Cv-Value	gal/min	1.9	4.4	5.0	7.8	13.4	16.2	23.9	26.3	43.2	82.7	120.9	195.2	401.8

Dimensions in mm.

Fire Safe and Offshore Valves

Type 01841 - Globe Valve



Cryogenic Globe Valves, DN200, PN25

"Fire safe" type test approval acc. to EN ISO 10497

Stainless steel body and topwork
"live loaded" gland packing

Part No. 01841.0219.001* (H=560)

Part No. 01841.0219.006* (H=1000)

*Butt weld connection for stainless steel pipes acc. to ISO 1127 or ASTM A312

Artikel-Nr. 01841.0219.00*4

Socket weld connection for stainless steel pipes acc. to ISO 1127 or ASTM A312

In flow direction, the valve with the nominal size DN200 is conform to tightness class L1 up to 9 bar maximum differential pressure acc. to DIN 12567 for LNG use. This standard can also be used for the tightness class of other cryogenic gases.

Available options - on request only

Applications:

Approved for air gases, vapours and cryogenic liquefied gases incl. LNG.

Working temperature: -196°C / -321°F (77K) up to +120°C / +248°F (393K)



Materials	DIN EN	ASTM
1 Body	1.4409	A 351 CF3M
2 Valve seal	PTFE / Carbon filled (25%)	
3 Disc	1.4404	A 276 Grade 316L
4 Bonnet gasket	Graphite	
5 Headpiece	1.4404	A 276 Grade 316L
6 Bolts	1.4571/A4	similar A 194 B8T
7 Elongation tube	1.4571	A 213 TP 316Ti
8 Stem	1.4404	A 276 Grade 316L
9 Gland packing	Graphite / PTFE / MICA	
10 Gland nut	1.4305	A 276 Grade 303
11 Handwheel	1.4409	A 351 CF3M
13 Bush	CW452K	B 159 UNS C51900

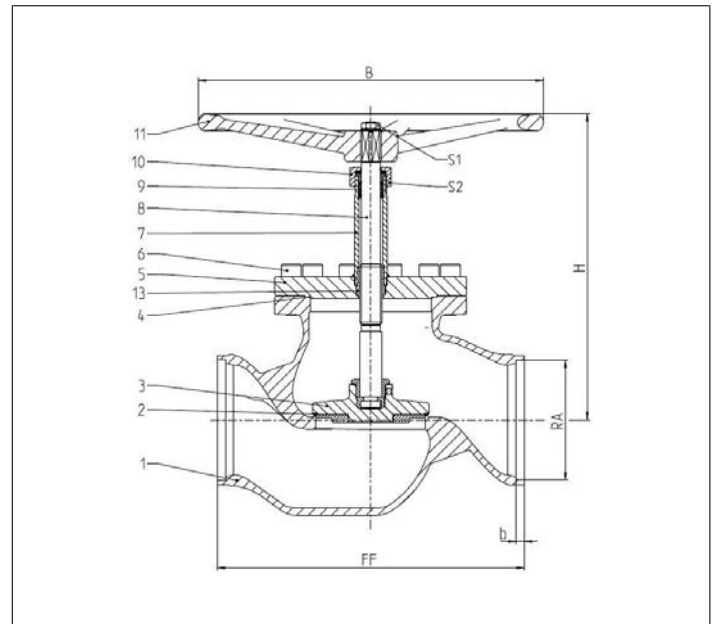

Standard marking acc. to Pressure Equipment Directive 97/23/EC (PED).



Type 01841 - Standard	Technical data	
Nominal size	DN	200
Dimension code	.X.	0219
Face-to-face dimension	FF	560
Height	H	1000
Outside pipe-Ø ISO 1127	RA	219.1
Wall thickness pipe ISO 1127	a	6.3
Outside pipe-Ø ASTM A312	RA	219.1
Wall thickness pipe ASTM A312	a	dimensions acc. to S10 or S40
Socket depth	b	15
Handwheel-Ø	B	630
Wrench size across flats	S ₁	30
Wrench size across flats	S ₂	65
Weight	ca. kg	135
Kvs-Value	m ³ /h	680
Cv-Value	gal/min	786

Dimensions in mm.



Fire Safe and Offshore Valves

Type 01841 - Globe Valve



Cryogenic-Globe and Globe/Check Valves, PN63
“Fire safe” type test approval acc. to EN ISO 10497

Stainless steel body and topwork,
 “live loaded” gland packing
 “cleaned and degreased”

Part No. 01841.X.001*P63 (H = 270mm)
Part No. 01841.X.002*P63 (H = 370mm)
Part No. 01841.X.501*P63 (H = 270mm) Globe/Check Valve
Part No. 01841.X.502*P63 (H = 370mm) Globe/Check Valve
 * Butt weld connection for stainless steel pipes acc. to ISO 1127 or ASTM A312

Part No. 01841.X.0014P63 (H = 270mm)
Part No. 01841.X.0024P63 (H = 370mm)
Part No. 01841.X.5014P63 (H = 270mm) Globe/Check Valve
Part No. 01841.X.5024P63 (H = 370mm) Globe/Check Valve
 Socket weld connection for stainless steel pipes acc. to ISO 1127 or ASTM A312

Available options - on request only:
 · Extension H up to 900mm
 · Valve with control disc (tapered design)

Applications:

Suitable for hydrogen, approved for air gases, vapours and cryogenic liquefied gases incl. LNG.
 Working temperature: -255°C / -427°F (18K) up to +120°C / +248°F (393K)



Materials	DIN EN	ASTM
1 Body	1.4409	A 351 CF3M
2 Valve seal	PTFE / Carbon filled (25%)	
3 Disc	1.4404	A 276 Grade 316L
4 Bonnet gasket	Graphite	
5 Headpiece	1.4404	A 276 Grade 316L
6 Bolts	1.4571/A4	similar A 194 B8T
7 Elongation tube	1.4571	A 213 TP 316Ti
8 Stem	1.4404	A 276 Grade 316L
9 Gland packing	Graphite / PTFE / MICA	
10 Gland nut	1.4305	A 276 Grade 303
11 Handwheel	1.4409	A 351 CF3M
12 Spring	1.4571	A 313 Grade 316Ti
13 Bush	CW452K	B 159 UNS C51900

Standard marking acc. to Pressure Equipment Directive 97/23/EC (PED).

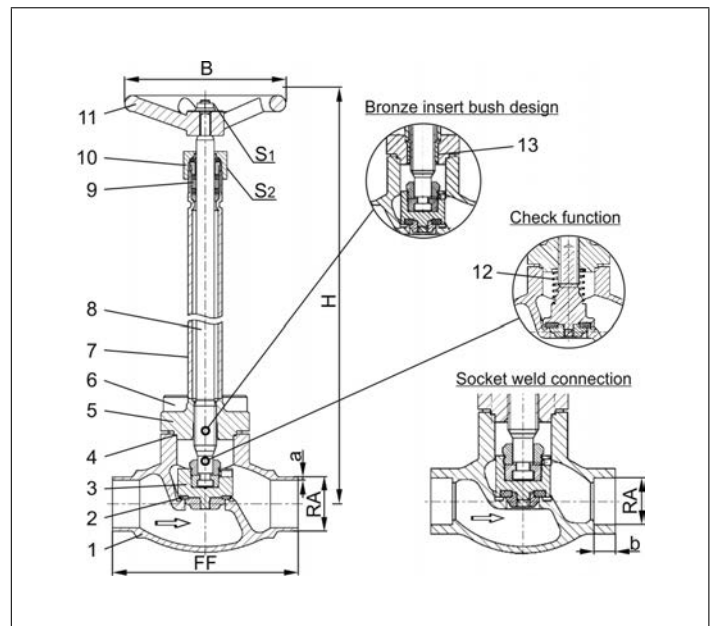

Type 01841 - Standard	Technical data												
	DN	10	15	15	20	25	32	40	40	50	65	80	100
Nominal size	.X.	1012	1517	1521	2026	2533	3238	4042	4048	5060	657x	8088	0114
Dimension code													
Face-to-face dimension	FF	70	85	85	100	115	115	130	130	155	205	245	280
Height	H	270 mm or 370 mm											
Outside pipe-Ø ISO 1127	RA	13.5	17.2	21.3	26.9	33.7	38.0	42.4	48.3	60.3	76.1	88.9	114.3
Wall thickness pipe ISO 1127	a	1.6	1.6	2.0	2.0	2.0	2.0	2.0	3.6	3.6	3.6	4.0	6.3
Outside pipe-Ø ASTM A312	RA	13.72	17.15	21.34	26.67	33.40	-	42.16	48.26	60.33	73.03	88.90	114.3
Wall thickness pipe ASTM A312	a	dimensions acc. to S40											
Socket depth	b	6	10	10	13	13	-	13	13	16	16	16	20
Handwheel-Ø	B	100	100	100	100	100	125	125	125	125	200	250	315
Wrench size across flats	S ₁	10	10	10	10	10	13	13	13	13	13	13	13
Wrench size across flats	S ₂	30	30	30	30	30	36	36	36	36	36	36	41
Weight	ca. kg	1.4	1.65	1.7	2.1	2.4	3.3	4.7	4.7	7.2	12.7	17.0	24.5
Kvs-Value	m ³ /h	1.6	3.8	4.3	6.7	11.5	14.0	20.6	22.6	37.1	71.1	104.0	170.0
Cv-Value	gal/min	1.9	4.4	5.0	7.8	13.4	16.2	23.9	26.3	43.2	82.7	120.9	195.2

Dimensions in mm.

Fire Safe and Offshore Valves

Type 01845 - Globe Valve



Cryogenic-Globe and Globe/Check Valves, PN50
"Fire safe" type test approval acc. to EN ISO 10497

Stainless steel body and topwork,
 "live loaded" gland packing
 "cleaned and degreased for oxygen service"

Part No. 01845.X.0011 (H = 270mm)
Part No. 01845.X.0021 (H = 370mm)
Part No. 01845.X.5011 (H = 270mm) Globe/Check Valve
Part No. 01845.X.5021 (H = 370mm) Globe/Check Valve
 Female thread connection (G) acc. to ISO 228/1

Part No. 01845.X.0016 (H = 270mm)
Part No. 01845.X.0026 (H = 370mm)
Part No. 01845.X.5016 (H = 270mm) Globe/Check Valve
Part No. 01845.X.5026 (H = 370mm) Globe/Check Valve
 Female thread connection NPT acc. to ANSI B 1.20.1

Available options - on request only:
 · Female thread connection (R) acc. to ISO 7-Rc
 · Extension H up to 900mm · Valve with control disc (tapered design)

Applications:

Suitable for hydrogen, approved for air gases, vapours and cryogenic liquefied gases incl. LNG.
 Working temperature: -255°C / -427°F (18K) up to +120°C / +248°F (393K)



Materials	DIN EN	ASTM
1 Body	1.4409	A 351 CF3M
2 Valve seal	PTFE / Carbon filled (25%)	
3 Disc	1.4404	A 276 Grade 316L
4 Bonnet gasket	Graphite	
5 Headpiece	1.4404	A 276 Grade 316L
6 Bolts	1.4571/A4	similar A 194
7 Elongation tube	1.4571	A 213 TP 316 Ti
8 Stem	1.4404	A 276 Grade 316L
9 Gland packing	Graphite / PTFE / MICA	
10 Gland nut	1.4305	A 276 Grade 303
11 Handwheel	1.4409	SA 351 CF3M
12 Spring	1.4571	A 313 Grade 316Ti
13 Bush	CW452K	B 159 UNS C51900

Standard marking acc. to Pressure Equipment Directive 97/23/EC (PED). **CE**

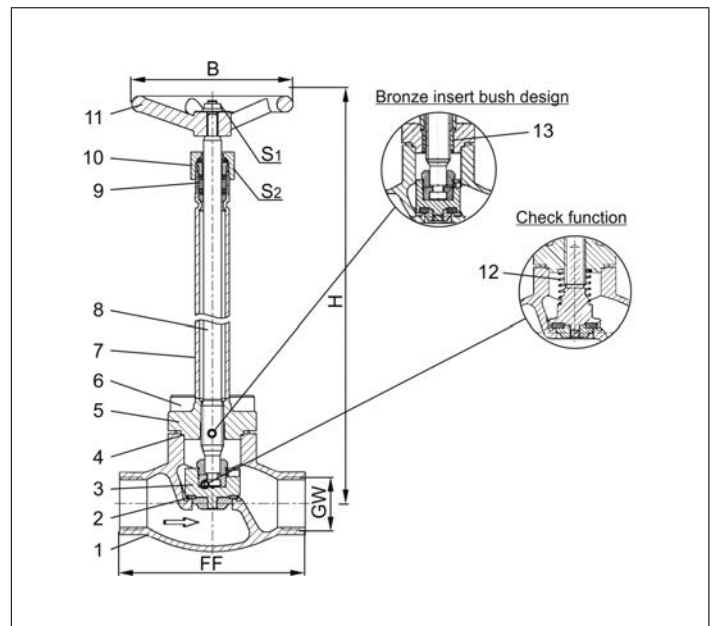

Type 01845	Technical data								
	DN	10	10	15	20	25	40	40	50
Nominal size	DN	10	10	15	20	25	40	40	50
Thread size	GW	1/4	3/8	1/2	3/4	1	1-1/4	1-1/2	2
Dimension code	.X.	0200	0300	0400	0600	1000	1200	1400	2000
Face-to-face dimension	FF	70	70	85	100	115	130	130	155
Height	H	270 mm or 370 mm							
Handwheel-Ø	B	100	100	100	100	100	125	125	125
Wrench size across flats	S ₁	10	10	10	10	10	13	13	13
Wrench size across flats	S ₂	30	30	30	30	30	36	36	36
Weight	ca. kg	1.4	1.4	1.7	2.1	2.4	4.7	4.7	7.2
Kvs-Value	m ³ /h	1.6	2.2	4.3	6.7	11.5	20.6	22.6	37.1
Cv-Value	gal/min	1.9	2.6	5.0	7.8	13.4	23.9	26.3	43.2

Dimensions in mm.



Fire Safe and Offshore Valves

Type 03841 - Globe Valve



Cryogenic-Globe and Globe/Check Valves, PN40
"Fire safe" type test approval acc. to EN ISO 10497

Stainless steel body and topwork,
 "live loaded" gland packing
 "cleaned and degreased for oxygen service"

Part No. 03841.X.0012 (H = 270mm)
Part No. 03841.X.0022 (H = 370mm)
Part No. 03841.X.5012 (H = 270mm) Globe/Check Valve
Part No. 03841.X.5022 (H = 370mm) Globe/Check Valve
 Flanged connection acc. to DIN EN 1092-1 PN40

Available options - on request only:
 · Nominal sizes DN15, DN20 and DN150 with welded flange



Applications:

Suitable for hydrogen, approved for air gases, vapours and cryogenic liquefied gases incl. LNG.
 Working temperature: -255°C / -427°F (18K) up to +120°C / +248°F (393K)

Materials	DIN EN	ASTM
1 Body	1.4409	A 351 CF3M
2 Valve seal	PTFE / Carbon filled (25%)	
3 Disc	1.4404	A 276 Grade 316L
4 Bonnet gasket	Graphite	
5 Headpiece	1.4404	A 276 Grade 316L
6 Bolts	1.4571/A4	similar A 194 B8T
7 Elongation tube	1.4571	A 213 TP 316Ti
8 Stem	1.4404	A 276 Grade 316L
9 Gland packing	Graphite / PTFE / MICA	
10 Gland nut	1.4404	A 276 Grade 316L
11 Handwheel	1.4409	SA 351 CF3M
12 Spring	1.4571	A 313 Grade 316Ti
13 Bush	CW452K	B 159 UNS C51900

Standard marking acc. to Pressure Equipment Directive 97/23/EC (PED).

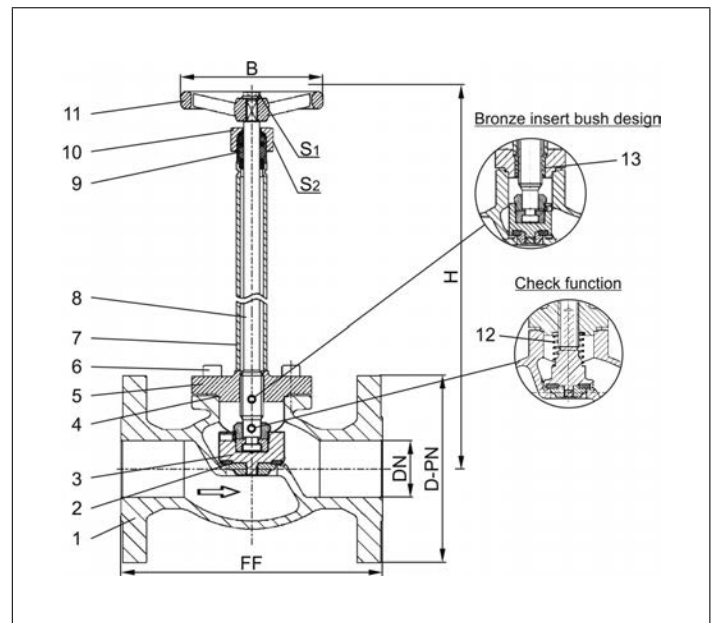

Type 03841	Technical data							
	Nominal size	DN	25	40	50	65	80	100
Dimension code - Flange EN 1092-1 PN40	.X.	0250	0400	0500	0650	0800	1000	
Flange-Ø	D-PN	115	150	165	185	200	235	
Face-to-face dimension	FF	160	200	230	290	310	350	
Height	H	270 mm or 370 mm						400
Handwheel-Ø	B	100	125	125	200	250	315	
Wrench size across flats	S ₁	10	13	13	13	13	13	
Wrench size across flats	S ₂	30	36	36	36	36	41	
Weight	ca. kg	4.9	9.7	13.3	21.1	28.0	43.2	
Kvs-Value	m ³ /h	11.5	22.6	37.1	71.1	104.0	170.0	
Cv-Value	gal/min	13.4	26.3	43.2	82.7	120.9	195.2	

Dimensions in mm.

Fire Safe and Offshore Valves

Type 03841 - Globe Valve



Cryogenic-Globe and Globe/Check Valves, class 300
"Fire safe" type test approval acc. to EN ISO 10497

Stainless steel body and topwork,
 "live loaded" gland packing
 "cleaned and degreased for oxygen service"

Part No. 03841.X.0013 (H = 270mm)
Part No. 03841.X.0023 (H = 370mm)
Part No. 03841.X.5013 (H = 270mm) Globe/Check Valve
Part No. 03841.X.5023 (H = 370mm) Globe/Check Valve
 Flanged connection acc. to ANSI B16.5 class 300

Available options - on request only:
 · Nominal sizes DN15, DN20 and DN150 with welded flange



Applications:

Suitable for hydrogen, approved for air gases, vapours and cryogenic liquefied gases incl. LNG.
 Working temperature: -255°C / -427°F (18K) up to +120°C / +248°F (393K)

Materials	DIN EN	ASTM
1 Body	1.4409	A 351 CF3M
2 Valve seal	PTFE / Carbon filled (25%)	
3 Disc	1.4404	A 276 Grade 316L
4 Bonnet gasket	Graphite	
5 Headpiece	1.4404	A 276 Grade 316L
6 Bolts	1.4571/A4	similar A 194 B8T
7 Elongation tube	1.4571	A 213 TP 316Ti
8 Stem	1.4404	A 276 Grade 316L
9 Gland packing	Graphite / PTFE / MICA	
10 Gland nut	1.4404	A 276 Grade 316L
11 Handwheel	1.4409	SA 351 CF3M
12 Spring	1.4571	A 313 Grade 316Ti
13 Bush	CW452K	B 159 UNS C51900

Standard marking acc. to Pressure Equipment Directive 97/23/EC (PED).

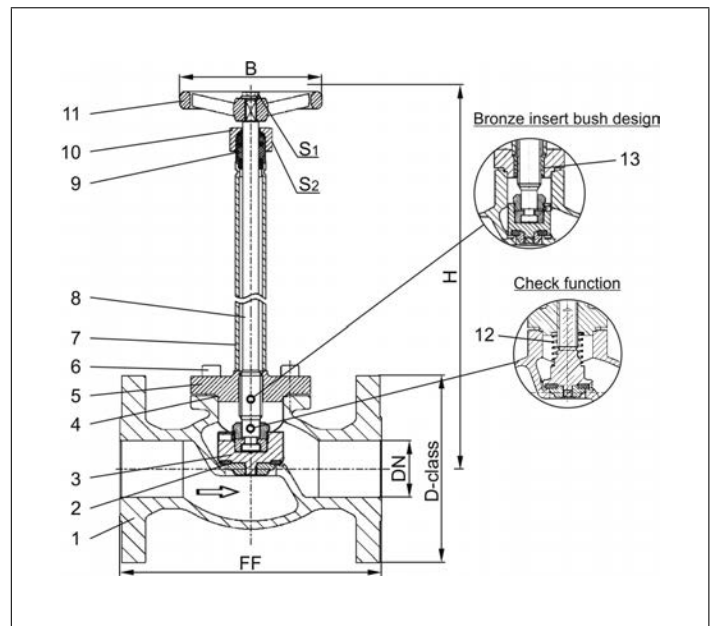

Type 03841	Technical data							
	Nominal size	DN	25	40	50	65	80	100
Dimension code - Flange ANSI B16.5 class 300	.X.	1000	1400	2000	2400	3000	4000	
Flange-Ø	D-class	123.9	155.4	165	190.5	209.5	254	
Face-to-face dimension	FF	160	200	230	290	310	350	
Height	H	270 mm or 370 mm						400
Handwheel-Ø	B	100	125	125	200	250	315	
Wrench size across flats	S ₁	10	13	13	13	13	13	
Wrench size across flats	S ₂	30	36	36	36	36	41	
Weight	ca. kg	4.9	9.7	13.3	21.1	28.0	43.2	
Kvs-Value	m ³ /h	11.5	22.6	37.1	71.1	104.0	170.0	
Cv-Value	gal/min	13.4	26.3	43.2	82.7	120.9	195.2	

Dimensions in mm.

Fire Safe and Offshore Valves

Type 01282 - Bellow Sealed Globe Valve



"Fire-safe"-design without fire type-testing according to EN ISO 10497

Cryogenic-Bellow Sealed Globe Valve, PN50

Stainless steel body and topwork,
 "live loaded" gland packing
 "cleaned and degreased for oxygen service"

Part No. 01282.X.002*

* Butt weld connection for stainless steel pipes acc. to ISO 1127 or ASTM A312

Part No. 01282.X.0024

Socket weld connection for stainless steel pipes acc. to ISO 1127 or ASTM A312

Available options - on request only:

- Welded stainless steel stubs acc. to ISO 1127 or ASTM A312 - length FF + 200mm
- Extension H up to 900mm



Applications:

Suitable for hydrogen, approved for air gases, vapours and cryogenic liquefied gases incl. LNG.

Working temperature: -255°C / -427°F (18K) up to +120°C / +248°F (393K)

Leak rate: 10^{-6} mbar ltr / sec outside, 10^{-4} mbar ltr / sec seat

Materials	DIN EN	ASTM
1 Body	1.4409	A 351 CF3M
2 Valve seal	PTFE / carbon filled (25%)	
3 Disc	1.4404	A 276 Grade 316L
4 Bonnet gasket	Graphite	
5 Headpiece	1.4404	A 276 Grade 316L
6 Bellow stem	1.4571	A 313 Grade 316Ti
7 Bolts	1.4571/A4	similar A 194 B8T
8 Bellow	1.4571	A 313 Grade 316Ti
9 Elongation tube	1.4571	A 313 Grade 316Ti
10 Headpiece	1.4404	A 276 Grade 316L
11 Bush	CW452K	B 159 UNS C51900
12 Stem	1.4404	A 276 Grade 316L
13 Gland packing	Graphite / PTFE / MICA	
14 Gland nut	1.4404	A 276 Grade 316L
15 Handwheel	Aluminium alloy	

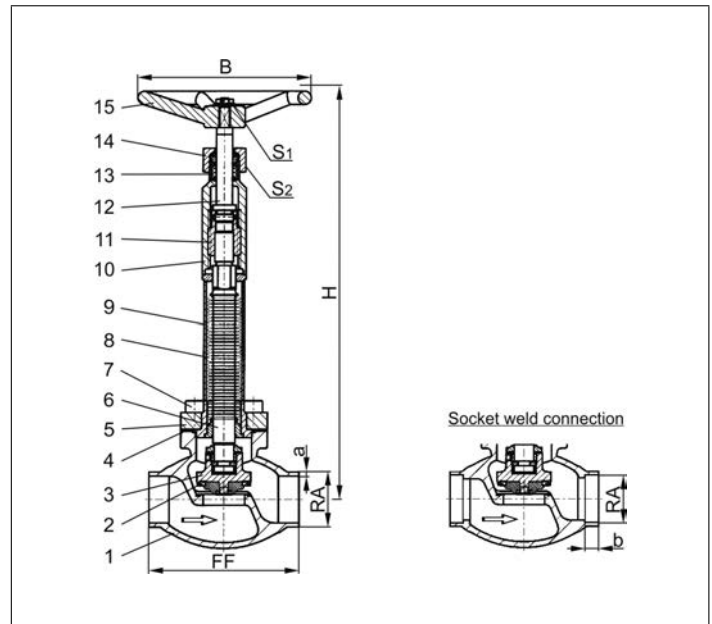

Standard marking acc. to Pressure Equipment Directive 97/23/EC (PED).



Type 01282 - Standard design	Technical data										
Nominal size	DN	10	15	15	20	25	32	40	40	50	
Dimension code	.X.	1012	1517	1521	2026	2533	3238	4042	4048	5060	
Face-to-face dimension	FF	70	85	85	100	115	115	130	130	155	
Height	H	380	380	380	380	380	380	380	380	380	
Outside pipe-Ø ISO 1127	RA	12.0	17.2	21.3	26.9	33.7	38.0	42.4	48.3	60.3	
Wall thickness pipe ISO 1127	a	1.0	1.6	2.0	2.0	2.0	2.0	2.0	2.0	2.0	
Outside pipe-Ø ASTM A312	RA	13.72	17.15	21.34	26.67	33.40	-	42.16	48.26	60.33	
Wall thickness pipe ASTM A312	a	dimensions acc. to S10 or S40									
Socket depth	b	6	10	10	13	13	-	13	13	16	
Handwheel-Ø	B	150	150	150	150	150	150	150	150	150	
Wrench size across flats	S ₁	10	10	10	10	10	13	13	13	13	
Wrench size across flats	S ₂	30	30	30	30	30	36	36	36	36	
Weight	ca. kg	1.6	1.85	1.9	2.3	2.7	3.6	5.1	5.1	7.7	
Kvs-Value	m ³ /h	1.6	2.8	4.3	6.7	11.5	14.0	20.6	22.6	37.1	
Cv-Value	gal/min	1.9	3.3	5.0	7.8	13.4	16.2	26.3	26.3	43.2	

Dimensions in mm.

Fire Safe and Offshore Valves

Type 01843 - Actuated Globe Valve



Cryogenic-Globe Valves with Pneumatic Actuator, PN50 (DN100/150=PN40)
“Fire safe” type test approval acc. to EN ISO 10497 (only actuator spring closes)

Stainless steel body and topwork
 Actuator - air opens, spring closes
 “live loaded” gland packing
 “cleaned and degreased for oxygen service” - the actuator is not cleaned and degreased for oxygen

Part No. 01843.X.301*

Butt weld connection for stainless steel pipes acc. to ISO 1127 or ASTM A312

Part No. 01843.X.3014

Socket weld connection for stainless steel pipes acc. to ISO 1127 or ASTM A312

Available accessories:

- Solenoid valve · Limit switch
- Electropneumatic positioner etc.

Available options - on request only:

- Welded stainless steel stubs acc. to ISO 1127 or ASTM A312 - length FF + 200mm
- Actuator “cleaned and degreased for oxygen service”



Applications:

Approved for air gases, vapours and cryogenic liquefied gases incl. LNG.
 Working temperature: -255°C / -427°F (18K) up to +120°C / +248°F (393K)

Materials	DIN EN	ASTM
1 Body	1.4409	A 351 CF3M
2 Valve seal	PTFE / Carbon filled (25%)	
3 Disc	1.4404	A 276 Grade 316L
4 Bonnet gasket	Graphite	
5 Headpiece	1.4404	A 276 Grade 316L
6 Bolts	1.4571/A4	similar A 194 B8T
7 Elongation tube	1.4571	A 213 TP 316Ti
8 Stem	1.4404	A 276 Grade 316L
9 Gland packing	Graphite / PTFE / MICA	
10 Gland nut	1.4404	A 276 Grade 316L
11 Pillars	1.4404	A 276 Grade 316L
12 Bush	CW452K	B 159 UNS C51900

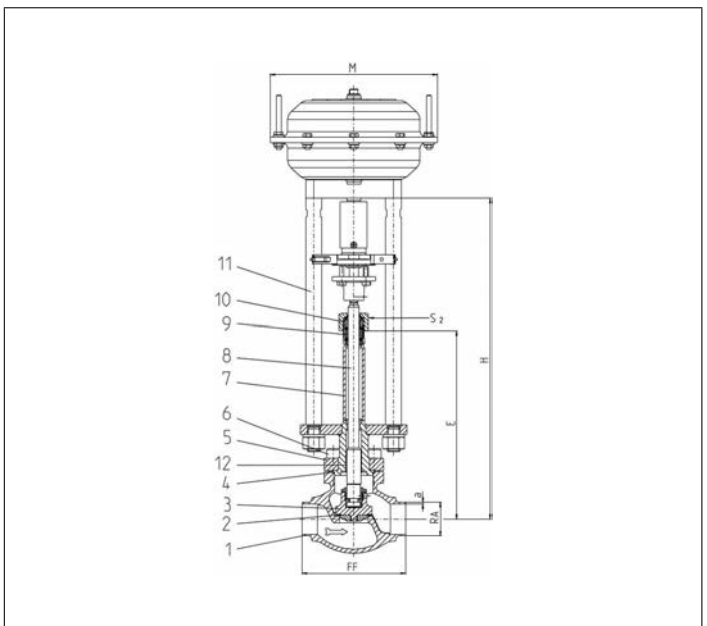

Standard marking acc. to Pressure Equipment Directive 97/23/EC (PED).



Type 01843 - Standard	Technical data														
	DN	10	15	15	20	25	32	40	40	50	65	80	100	150	
Nominal size	DN	10	15	15	20	25	32	40	40	50	65	80	100	150	
Dimension code	.X.	1012	1517	1521	2026	2533	3238	4042	4048	5060	657x	8088	0114	0168	
Face-to-face dimension	FF	70	85	85	100	115	115	130	130	155	205	245	280	400	
Height	H	370	370	370	370	375	405	420	420	425	510	575	635	685	
Length	E	195	195	195	200	200	230	230	230	235	300	300	300	300	
Outside pipe-Ø ISO 1127	RA	12.0	17.2	21.3	26.9	33.7	38.0	42.4	48.3	60.3	76.1	88.9	114.3	168.3	
Wall thickness pipe ISO 1127	a	1.0	1.6	2.0	2.0	2.0	2.0	2.0	2.0	2.0	2.6	3.2	6.0	7.1	
Outside pipe-Ø ASTM A312	RA	13.72	17.15	21.34	26.67	33.40	-	42.16	48.26	60.33	73.03	88.90	114.3	168.3	
Wall thickness pipe ASTM A312	a	dimensions acc. to S10 or S40													
Socket depth	b	6	10	10	13	13	-	13	13	16	16	16	20	20	
Actuator-Ø	M	dependent on actuator													
Wrench size across flats	S ₂	30	30	30	30	30	36	36	36	36	36	36	41	41	
Weight w/o actuator	ca. kg	1.9	2.15	2.2	2.4	3.1	3.8	6.5	6.5	9.0	15.2	20.0	28.0	60.9	
Kvs-Value	m ³ /h	1.6	3.8	4.3	6.7	11.5	14.0	20.6	22.6	37.1	71.1	104.0	170.0	350.0	
Cv-Value	gal/min	1.9	4.4	5.0	7.8	13.4	16.2	23.9	26.3	43.2	82.7	120.9	195.2	401.8	
Stroke	mm	10	10	10	7	9	9	11	11	15	23	23	30	40	

Dimensions in mm. Compliance of tightness requirements acc. to EN 1626 for DN150 up to 20 bar differential pressure. In the range of >20-40 bar, 350-700ml (1 bar, 20°C [68°F]) are reached.



Fire Safe and Offshore Valves

Type 01853 - Actuated Trailervalue



Cryogenic-Globe Valves with Pneumatic Actuator, PN50
"Fire safe" type test approval acc. to EN ISO 10497

air pressure for operation 4.0 bar g (maximum 10.0 bar g)
 Stainless steel body and topwork,
 Actuator - air opens, spring closes
 "live loaded" gland packing
 "cleaned and degreased for oxygen service" - the actuator is not cleaned and degreased for oxygen
 maximum working pressure of the valve depending on nominal size

Part No. 01853.X.T0**

* Butt weld connection for stainless steel pipes acc. to ISO 1127 or ASTM A312

Part No. 01853.X.T0*4

Socket weld connection for stainless steel pipes acc. to ISO 1127 or ASTM A312

Available options - on request only:

· Welded stainless steel stubs acc. to ISO 1127 or ASTM A312 - length FF + 200mm

Applications:

Approved for air gases, vapours and cryogenic liquefied gases incl. LNG.

Working temperature: -255°C / -427°F (18K) up to +120°C / +248°F (393K)



Materials	DIN EN	ASTM
1 Body	1.4409	A 351 CF3M
2 Valve seal	PTFE / Carbon filled (25%)	
3 Disc	1.4404	A 276 Grade 316L
4 Bonnet gasket	Graphite	
5 Headpiece	1.4404	A 276 Grade 316L
6 Bolts	1.4571/A4	similar A 194
7 Elongation tube	1.4571	A 213 TP 316Ti
8 Stem	1.4404	A 276 Grade 316L
9 Spring	1.4571	A 313 Grade 316Ti
10 Flange	1.4404	A 276 Grade 316L
11 Headpiece	1.4404	A 276 Grade 316L
12 Gland packing	Graphite / PTFE / MICA	
13 Gland nut	1.4571	A 313 Grade 316Ti
14 Pillars	1.4404	A 276 Grade 316L
15 Bush	CW452K	B 159 UNS C51900
16 Actuator	Rubber	

Standard marking acc. to Pressure Equipment Directive 97/23/EC (PED).

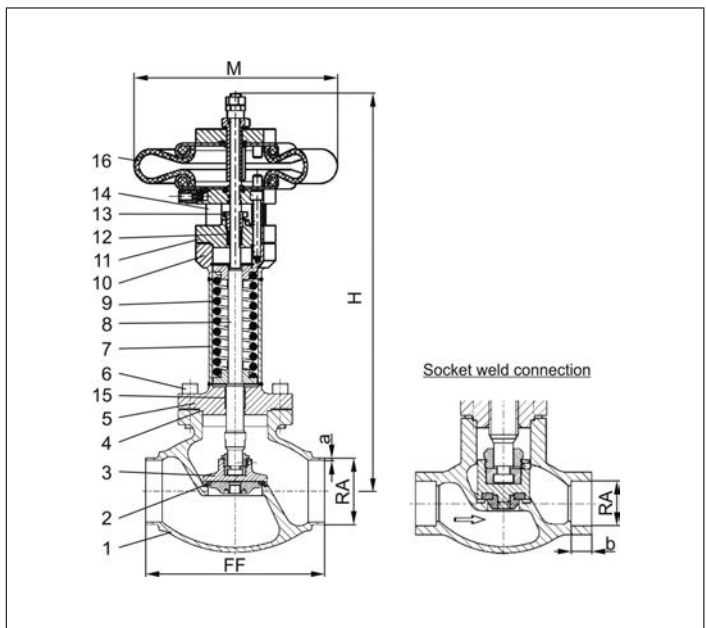

Type 01853	Technical data							
	DN	15	25	40	40	50	65	80
Nominal size	.X.	1521	2533	4042	4048	5060	657x	8088
Dimension code	.X.	1521	2533	4042	4048	5060	657x	8088
Face-to-face dimension	FF	85	115	130	130	155	205	245
Height	H	395	444	400	400	440	470	500
Outside pipe-Ø ISO 1127	RA	21.3	33.7	42.4	48.3	60.3	76.1	88.9
Wall thickness pipe ISO 1127	a	2.0	2.0	2.0	2.0	2.0	2.6	3.2
Outside pipe-Ø ASTM A312	RA	21.34	33.40	42.16	48.26	60.33	73.03	88.90
Wall thickness pipe ASTM A312	a	dimensions acc. to S10 or S40						
Socket depth	b	10	13	13	13	16	16	16
Actuator-Ø	M	229	229	229	229	229	229	229
Weight	ca. kg	7.2	9.1	10.5	10.5	14.5	17.4	22.5
Kvs-Value	m ³ /h	4.3	11.5	22.6	22.6	37.1	71.1	104.0
Cv-Value	gal/min	5.0	13.4	23.9	26.3	43.2	82.7	120.9
Stroke	mm	10	9	11	11	15	23	23

Dimensions in mm.

Spare Parts Firesafe and Offshore Applications

Type 28651 - Topwork



for Cryogenic-Globe and Globe/Check Valves
 "Fire safe" type test approval acc. to EN ISO 10497

Stainless steel topwork,
 "live loaded" gland packing
 "cleaned and degreased for oxygen service"

Part No. 28651.X.0000

Part No. 28651.X.5000 with check function

suitable for:

Type	Nominal size
01651	DN10 - DN100
01655	DN10 - DN50
03651	DN25 - DN150



Materials	DIN EN	ASTM
1 Valve seal	PTFE / Carbon filled (25%)	
2 Disc	1.4301	A 276 Grade 304
3 Bonnet gasket	Graphite	
4 Headpiece	1.4301 / 1.4308	A 276 Grade 304 / A 351 CF8
5 Bolts	1.4301/A2	A 194 B8
6 Stem	1.4301	A 276 Grade 304
7 Gland packing	Graphite / PTFE / MICA	
8 Gland nut	1.4305	A 276 Grade 303
9 Handwheel	1.4409	SA 351 CF3M
10 Spring	1.4310	A 313 Grade 301
11 Bush	CW452K	B 159 UNS C51900

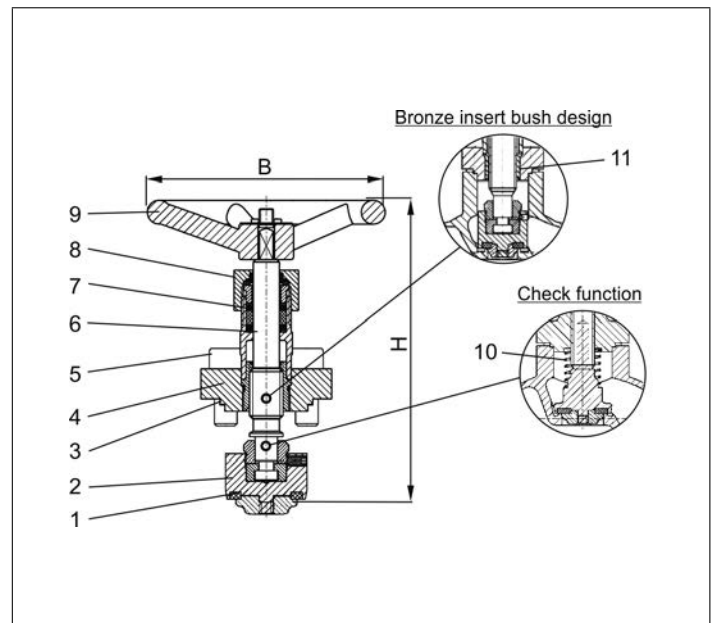

Type 28651	Technical data											
	DN	10	15	20	25	32	40	50	65	80	100	150
Nominal size	DN	10	15	20	25	32	40	50	65	80	100	150
Dimension code	.X.	0100	0150	0200	0250	0320	0400	0500	0650	0800	1000	1500
Height	H	130	130	130	130	155	160	185	240	285	320	380
Nimber of bolts		4	4	4	4	4	4	6	6	6	6	12
Handwheel-Ø	B	100	100	100	100	125	125	125	200	250	315	360
Weight	ca. kg	0.6	0.7	0.95	1.0	1.5	1.9	2.7	4.8	5.9	8.4	18.0

Dimensions in mm.

Edition 2016-01



Spare Parts Firesafe and Offshore Applications

Type 28641 - Topwork



for Cryogenic-Globe and Globe/Check Valves
 "Fire safe" type test approval acc. to EN ISO 10497

Stainless steel topwork,
 "live loaded" gland packing
 "cleaned and degreased for oxygen service"

Part No. 28641.X.0010 (H=270mm)

Part No. 28641.X.0020 (H=370mm)

Part No. 28641.X.5010 (H=270mm) with check function

Part No. 28641.X.5020 (H=370mm) with check function

suitable for:

Type	Nominal size
01641	DN10 - DN150
01645	DN10 - DN50
03641	DN25 - DN150



Materials	DIN EN	ASTM
1 Valve seal	PTFE / Carbon filled (25%)	
2 Disc	1.4301	A 276 Grade 304
3 Bonnet gasket	Graphite	
4 Headpiece	1.4301 / 1.4308	A 276 Grade 304 / A 351 CF8
5 Bolts	1.4301/A2	A 194 B8
6 Elongation tube	1.4541	A 213 TP 321
7 Stem	1.4301	A 276 Grade 304
8 Gland packing	Graphite / PTFE / MICA	
9 Gland nut	1.4305	A 276 Grade 303
10 Handwheel	1.4409	SA 351 CF3M
11 Spring	1.4310	A 313 Grade 301
12 Bush	CW452K	B 159 UNS C51900

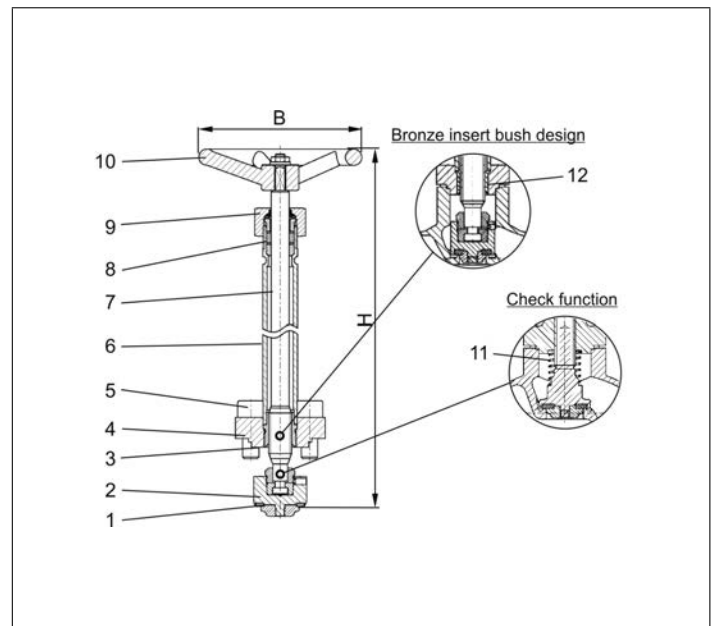

Type 28641	Technical data											
Nominal size	DN	10	15	20	25	32	40	50	65	80	100	150
Dimension code	.X.	0100	0150	0200	0250	0320	0400	0500	0650	0800	1000	1500
Height	H	270 mm or 370mm							400	400	400	420
Number of bolts		4	4	4	4	4	4	6	6	6	6	6
Handwheel-Ø	B	100	100	100	100	125	125	125	200	250	315	350
Weight	ca. kg	1.0	1.1	1.4	1.4	2.0	2.4	3.0	5.5	6.8	9.5	18.4

Dimensions in mm.

Spare Parts Firesafe and Offshore Applications

Type 28751 - Topwork



for Cryogenic-Globe and Globe/Check Valves

Stainless steel topwork,
 "live loaded" gland packing
 "cleaned and degreased for oxygen service"

Part No. 28751.X.0000

Part No. 28751.X.5000 with check function

suitable for:

Type	Nominal size
01751	DN10 - DN100
01755	DN10 - DN50
03751	DN25 - DN150



Materials	DIN EN	ASTM
1 Valve seal	PCTFE (Kel-F)	
2 Disc	1.4401	A 276 Grade 316
3 Bonnet gasket	Graphite	
4 Headpiece	1.4404	A 276 Grade 316L
5 Bolts	1.4571/A4	similar A 194 B8T
6 Stem	1.4401	A 276 Grade 316
7 Gland packing	Graphite / PTFE / MICA	
8 Gland nut	1.4305	A 276 Grade 303
9 Handwheel	1.4409	SA 351 CF3M
10 Spring	1.4571	A 313 Grade 316Ti
11 Bush	CW452K	B 159 UNS C51900

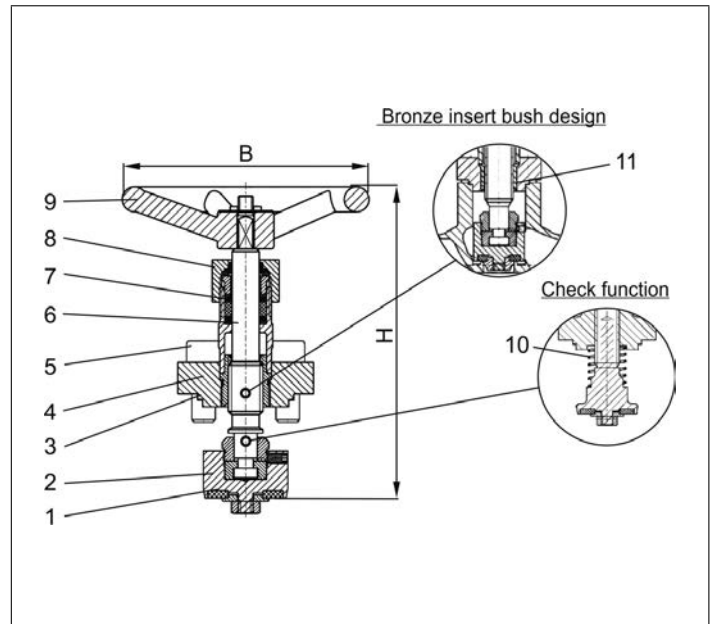

Type 28751	Technical data											
Nominal size	DN	10	15	20	25	32	40	50	65	80	100	150
Dimension code	.X.	0100	0150	0200	0250	0320	0400	0500	0650	0800	1000	1500
Height	H	130	130	130	130	155	160	185	240	285	320	380
Number of bolts		4	4	4	4	4	4	6	6	6	6	12
Handwheel-Ø	B	100	100	100	100	125	125	125	200	250	315	360
Weight	ca. kg	0.6	0.7	0.95	1.0	1.5	1.9	2.7	4.8	5.9	8.4	18.0

Dimensions in mm.

Edition 2016-01



Spare Parts Firesafe and Offshore Applications

Type 28741 - Topwork



for Cryogenic-Globe and Globe/Check Valves

Stainless steel topwork,
 "live loaded" gland packing
 "cleaned and degreased for oxygen service"

Part No. 28741.X.0010 (H=270mm)

Part No. 28741.X.0020 (H=370mm)

Part No. 28741.X.5010 (H=270mm) with check function

Part No. 28741.X.5020 (H=370mm) with check function

suitable for:

Type	Nominal size
01741	DN10 - DN150
01745	DN10 - DN50
03741	DN25 - DN150



Materials	DIN EN	ASTM
1 Valve seal	PCTFE (Kel-F)	
2 Disc	1.4401	A 276 Grade 316
3 Bonnet gasket	Graphite	
4 Headpiece	1.4404	A 276 Grade 316L
5 Bolts	1.4571/A4	similar A 194 B8T
6 Elongation tube	1.4571	A 213 TP 316Ti
7 Stem	1.4401	A 276 Grade 316
8 Gland packing	Graphite / PTFE / MICA	
9 Gland nut	1.4305	A 276 Grade 303
10 Handwheel	1.4409	SA 351 CF3M
11 Spring	1.4571	A 313 Grade 316Ti
12 Bush	CW452K	B 159 UNS C51900

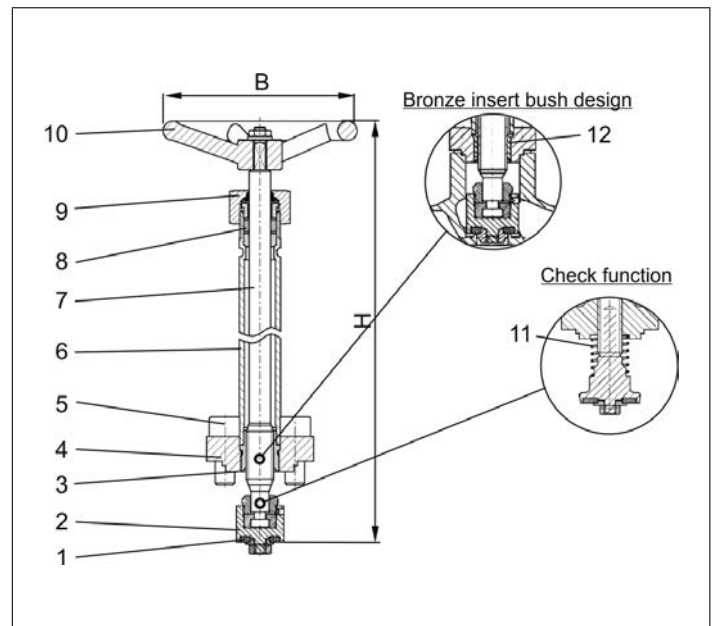

Type 28741	Technical data											
Nominal size	DN	10	15	20	25	32	40	50	65	80	100	150
Dimension code	.X.	0100	0150	0200	0250	0320	0400	0500	0650	0800	1000	1500
Height	H	270mm or 370mm							400	400	400	420
Number of bolts		4	4	4	4	4	4	6	6	6	6	12
Handwheel-Ø	B	100	100	100	100	125	125	125	200	250	315	360
Weight	ca. kg	1.0	1.1	1.4	1.4	2.0	2.4	3.0	5.5	6.8	9.5	19.0

Dimensions in mm.

Spare Parts Firesafe and Offshore Applications

Type 28851 - Topwork



for Cryogenic-Globe and Globe/Check Valves

“Fire safe” type test approval acc. to EN ISO 10497

Stainless steel topwork,

“live loaded” gland packing

“cleaned and degreased for oxygen service”

Part No. 28851.X.0000

Part No. 28851.X.5000 with check function

suitable for:

Type	Nominal size
01851	DN10 - DN100
01855	DN10 - DN50
03851	DN25 - DN150



Materials	DIN EN	ASTM
1 Valve seal	PTFE / Carbon filled (25%)	
2 Disc	1.4401	A 276 Grade 316
3 Bonnet gasket	Graphite	
4 Headpiece	1.4404	A 276 Grade 316L
5 Bolts	1.4571/A4	similar A 194 B8T
6 Stem	1.4401	A 276 Grade 316
7 Gland packing	Graphite / PTFE / MICA	
8 Gland nut	1.4305	A 276 Grade 303
9 Handwheel	1.4409	SA 351 CF3M
10 Spring	1.4571	A 313 Grade 316Ti
11 Bush	CW452K	B 159 UNS C51900

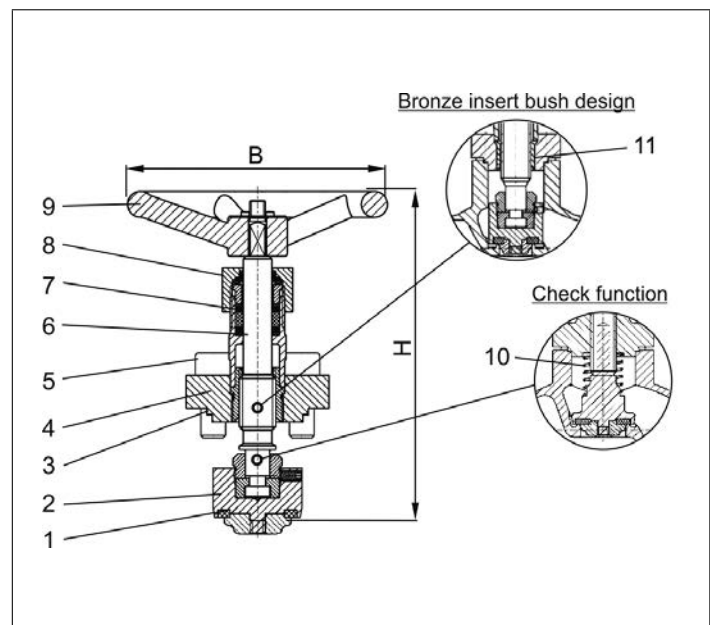

Type 28851	Technical data											
Nominal size	DN	10	15	20	25	32	40	50	65	80	100	150
Dimension code	.X.	0100	0150	0200	0250	0320	0400	0500	0650	0800	1000	1500
Height	H	130	130	130	130	155	160	185	240	285	320	380
Number of bolts		4	4	4	4	4	4	6	6	6	6	12
Handwheel-Ø	B	100	100	100	100	125	125	125	200	250	315	360
Weight	ca. kg	0.6	0.7	0.95	1.0	1.5	1.9	2.7	4.8	5.9	8.4	18.0

Dimensions in mm.

Edition 2016-01

Spare Parts Firesafe and Offshore Applications

Type 28841 - Topwork

for Cryogenic-Globe and Globe/Check Valves

“Fire safe” type test approval acc. to EN ISO 10497

Stainless steel topwork,
“live loaded” gland packing
“cleaned and degreased for oxygen service”

Part No. 28841.X.0010 (H=270mm)

Part No. 28841.X.0020 (H=370mm)

Part No. 28841.X.5010 (H=270mm) with check function

Part No. 28841.X.5020 (H=370mm) with check function

suitable for:

Type	Nominal size
01841	DN10 - DN100
01845	DN10 - DN50
03841	DN25 - DN150



Materials	DIN EN	ASTM
1 Valve seal	PTFE / Carbon filled (25%)	
2 Disc	1.4401	A 276 Grade 316
3 Bonnet gasket	Graphite	
4 Headpiece	1.4404	A 276 Grade 316L
5 Bolts	1.4571/A4	similar A 194 B8T
6 Elongation tube	1.4571	A 213 TP 316Ti
7 Stem	1.4401	A 276 Grade 316
8 Gland packing	Graphite / PTFE / MICA	
9 Gland nut	1.4305	A 276 Grade 303
10 Handwheel	1.4409	SA 351 CF3M
11 Spring	1.4571	A 313 Grade 316Ti
12 Bush	CW452K	B 159 UNS C51900

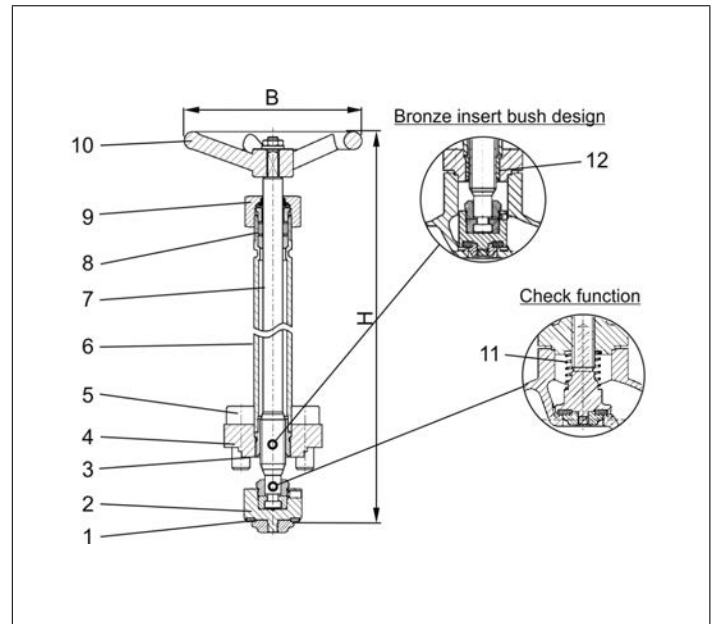

Type 28841	Technical data											
Nominal size	DN	10	15	20	25	32	40	50	65	80	100	150
Dimension code	.X.	0100	0150	0200	0250	0320	0400	0500	0650	0800	1000	1500
Height	H	270mm or 370mm							400	400	400	420
Number of bolts		4	4	4	4	4	4	6	6	6	6	12
Handwheel-Ø	B	100	100	100	100	125	125	125	200	250	315	360
Weight	ca. kg	1.0	1.1	1.4	1.4	2.0	2.4	3.0	5.5	6.8	9.5	19.0

Dimensions in mm.

Spare Parts Firesafe and Offshore Applications

Type 28203, Type 29203 - Disc complete



for Cryogenic-Globe Valves

stainless steel disc 1.4404

"cleaned and degreased for oxygen service"

Part No. 28203.X.0783

suitable for:

Type	Nominal size
01751, 01741	DN10 - DN150
01755, 01745	DN10 - DN50

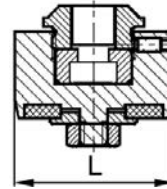

Type 28203.X.0000	Technical data											
Nominal size	DN	10	15	20	25	32	40	50	65	80	100	150
Dimension code	.X.	0100	0150	0200	0250	0320	0400	0500	0650	0800	1000	1500
Disc Ø	L	23	25	30	34.5	42	47	55	73	86	104	155
Weight	ca. kg	0.05	0.06	0.09	0.12	0.18	0.22	0.30	0.55	0.75	1.05	3.10

Dimensions in mm.

for Cryogenic-Globe Valves

stainless steel disc 1.4301

"cleaned and degreased for oxygen service"

Part No. 29203.X.0765

suitable for:

Type	Nominal size
01651	DN10 - DN100
01641	DN10 - DN200
01655, 01645	DN10 - DN50
03651, 03641	DN25 - DN100

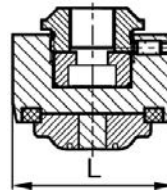

Type 29203.X.0765	Technical data											
Nominal size	DN	10	15	20	25	32	40	50	65	80	100	150
Dimension code	.X.	0100	0150	0200	0250	0320	0400	0500	0650	0800	1000	1500
Disc Ø	L	23	25	30	34.5	42	47	55	73	86	104	155
Weight	ca. kg	0.05	0.06	0.09	0.12	0.18	0.22	0.30	0.55	0.75	1.05	3.10

Dimensions in mm.

for Cryogenic-Globe Valves

stainless steel disc 1.4404

"cleaned and degreased for oxygen service"

Artikel-Nr. 29203.X.0783

suitable for:

Type	Nominal size
01851	DN10 - DN100
01841	DN10 - DN200
01855, 01845	DN10 - DN50
03851, 03841	DN25 - DN150

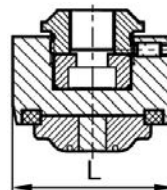

Type 29203.X.0783	Technical data											
Nominal size	DN	10	15	20	25	32	40	50	65	80	100	150
Dimension code	.X.	0100	0150	0200	0250	0320	0400	0500	0650	0800	1000	1500
Disc Ø	L	23	25	30	34.5	42	47	55	73	86	104	155
Weight	ca. kg	0.05	0.06	0.09	0.12	0.18	0.22	0.30	0.55	0.75	1.05	3.10

Dimensions in mm.



Spare Parts Firesafe and Offshore Applications

Type 28205, Type 29205 - Check Disc complete



for Cryogenic-Globe/Check Valves

stainless steel check disc 1.4301

"cleaned and degreased for oxygen service"

Part No. 29205.X.5765

suitable for:

Type	Nominal size
01651	DN10 - DN100
01641	DN10 - DN150
01655, 01645	DN10 - DN50
03651, 03641	DN25 - DN150

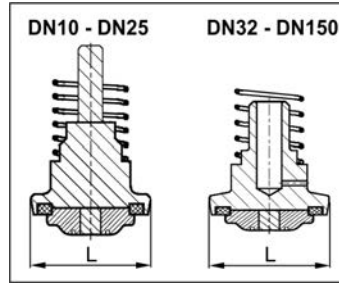

Type	Technical data											
Type	DN	10	15	20	25	32	40	50	65	80	100	150
Nominal size	DN	10	15	20	25	32	40	50	65	80	100	150
Dimension code	.X.	0100	0150	0200	0250	0320	0400	0500	0650	0800	1000	1500
Disc Ø	L	23	25	30	34.5	42	47	55	73	86	104	155
Weight	ca. kg	0.05	0.07	0.09	0.10	0.15	0.20	0.34	0.48	0.66	1.05	3.28

Dimensions in mm.

for Cryogenic-Globe/Check Valves

stainless steel check disc 1.4404

"cleaned and degreased for oxygen service"

Part No. 29205.X.5783

suitable for:

Type	Nominal size
01851	DN10 - DN100
01841	DN10 - DN150
01855, 01845	DN10 - DN50
03851, 03841	DN25 - DN150

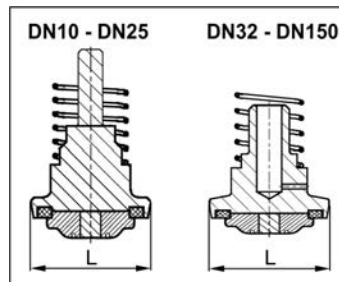

Type	Technical data											
Type	DN	10	15	20	25	32	40	50	65	80	100	150
Nominal size	DN	10	15	20	25	32	40	50	65	80	100	150
Dimension code	.X.	0100	0150	0200	0250	0320	0400	0500	0650	0800	1000	1500
Disc Ø	L	23	25	30	34.5	42	47	55	73	86	104	155
Weight	ca. kg	0.05	0.07	0.09	0.10	0.15	0.20	0.34	0.48	0.66	1.05	3.28

Dimensions in mm.

for Cryogenic-Globe/Check Valves

stainless steel check disc 1.4404

"cleaned and degreased for oxygen service"

Part No. 28205.X.5783

suitable for:

Type	Nominal size
01751, 01741	DN10 - DN150
01755, 01745	DN10 - DN50
03751, 03741	DN25 - DN150

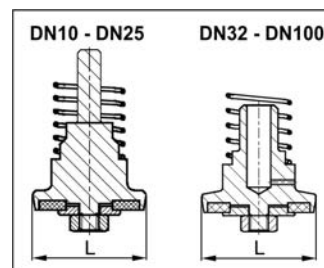

Type	Technical data											
Type	DN	10	15	20	25	32	40	50	65	80	100	150
Nominal size	DN	10	15	20	25	32	40	50	65	80	100	150
Dimension code	.X.	0100	0150	0200	0250	0320	0400	0500	0650	0800	1000	1500
Disc Ø	L	23	25	30	34.5	42	47	55	73	86	104	155
Weight	ca. kg	0.05	0.07	0.09	0.10	0.15	0.20	0.34	0.48	0.66	1.05	3.28

Dimensions in mm.

Spare Parts Firesafe and Offshore Applications

Type 28206, Type 29206 - Check Disc complete



for Cryogenic-Check Valves

stainless steel check disc 1.4404

"cleaned and degreased for oxygen service"

Part No. 28206.X.0783

suitable for:

Type	Nominal size
05714	DN10 - DN100
05717	DN10 - DN50
05719	DN25 - DN100

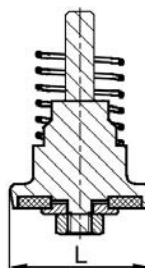

Type 28206.X.0783	Technical data											
Nominal size	DN	10	15	20	25	32	40	50	65	80	100	150
Dimension code	.X.	0100	0150	0200	0250	0320	0400	0500	0650	0800	1000	1500
Disc Ø	L	23	25	30	34.5	42	47	55	73	86	104	155
Weight	ca. kg	0.05	0.07	0.09	0.10	0.15	0.20	0.34	0.48	0.66	1.05	3.25

Dimensions in mm.

for Cryogenic-Check Valves

stainless steel check disc 1.4404

"cleaned and degreased for oxygen service"

Part No. 29206.X.0783

suitable for:

Type	Nominal size
05614	DN10 - DN100

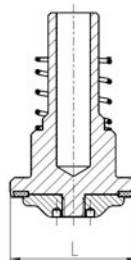

Type 29206.X.0783	Technical data											
Nominal size	DN	10	15	20	25	32	40	50	65	80	100	150
Dimension code	.X.	0100	0150	0200	0250	0320	0400	0500	0650	0800	1000	1500
Disc Ø	L	23	25	30	34.5	42	47	55	73	86	104	155
Weight	ca. kg	0.05	0.07	0.09	0.10	0.15	0.20	0.34	0.48	0.66	1.05	3.25

Dimensions in mm.

Spare Parts Firesafe and Offshore Applications

Type 30641 - Sealing spare part kit



for Cryogenic-Globe Valves

"cleaned and degreased for oxygen service"

Part No. 30641.X.0000

consisting of:

- 1x Bonnet gasket Graphite
- 1x Gland packing kit complete PTFE/Graphite
- 2x Stem gasket Mica

suitable for:

Type	Nominal size
01651, 01851, 01841	DN10 - DN100
01641	DN10 - DN150
01655, 01645, 01855, 01845	DN10 - DN50
03651, 03641	DN25 - DN150
03851, 03841	DN25 - DN100

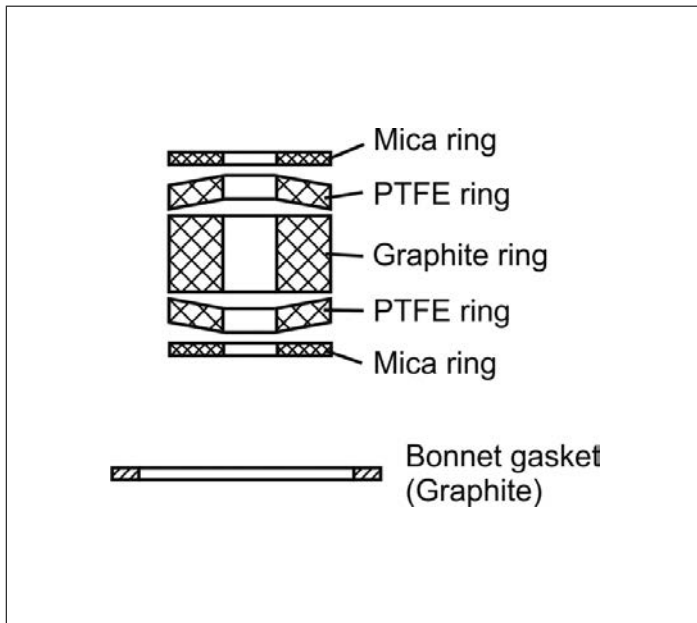
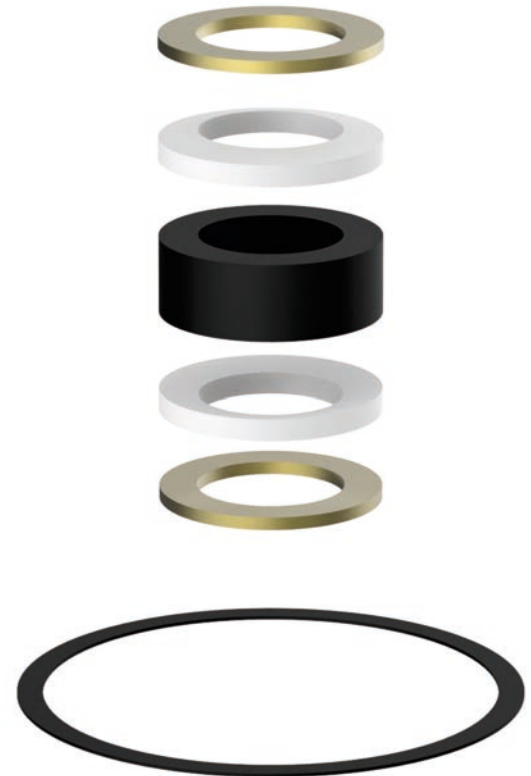

Type 30641	Technical data											
	DN	10	15	20	25	32	40	50	65	80	100	150
Nominal size	.X.	0100	0150	0200	0250	0320	0400	0500	0650	0800	1000	1500
Dimension code	.X.	0100	0150	0200	0250	0320	0400	0500	0650	0800	1000	1500
Weight	ca. kg	0.04	0.04	0.05	0.06	0.08	0.09	0.14	0.19	0.25	0.34	0.39

Dimensions in mm.

Spare Parts Firesafe and Offshore Applications

Type 30741 - Sealing spare part kit



for Cryogenic-Globe Valves

"cleaned and degreased for oxygen service"

Part No. 30741.X.0000

consisting of:

- 1x Bonnet gasket Graphite
- 1x Disc seal PCTFE
- 1x Disc nut 1.4571
- 1x Gland packing kit complete PTFE/Graphite
- 2x Stem gasket Mica

suitable for:

Type	Nominal size
01751, 01741	DN10 - DN150
01755, 01745	DN10 - DN50
03751, 03741	DN25 - DN150

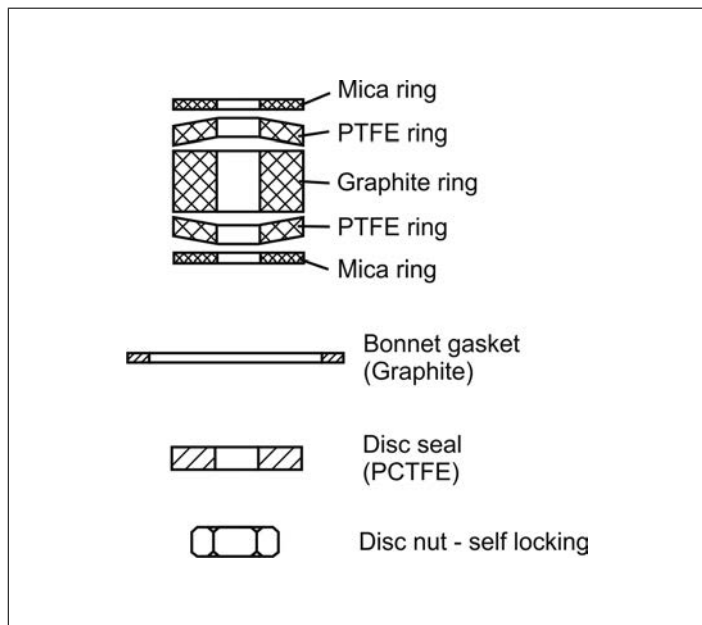

Type 30741	Technical data											
	DN	10	15	20	25	32	40	50	65	80	100	150
Dimension code	.X.	0100	0150	0200	0250	0320	0400	0500	0650	0800	1000	1500
Weight	ca. kg	0.03	0.03	0.04	0.05	0.07	0.08	0.13	0.18	0.24	0.32	0.44

Dimensions in mm.

Edition 2016-01

Spare Parts Firesafe and Offshore Applications

Type 30714 - Sealing spare part kit



for Cryogenic-Check Valves

"cleaned and degreased for oxygen service"

Part No. 30714.X.0000

consisting of:

- 1x Bonnet gasket Graphite
- 1x Disc seal PTFE / Carbon filled (25%)
- 1x Disc nut 1.4571

suitable for:

Type	Nominal size
05714	DN10 - DN100
05717	DN10 - DN50
05719	DN25 - DN100

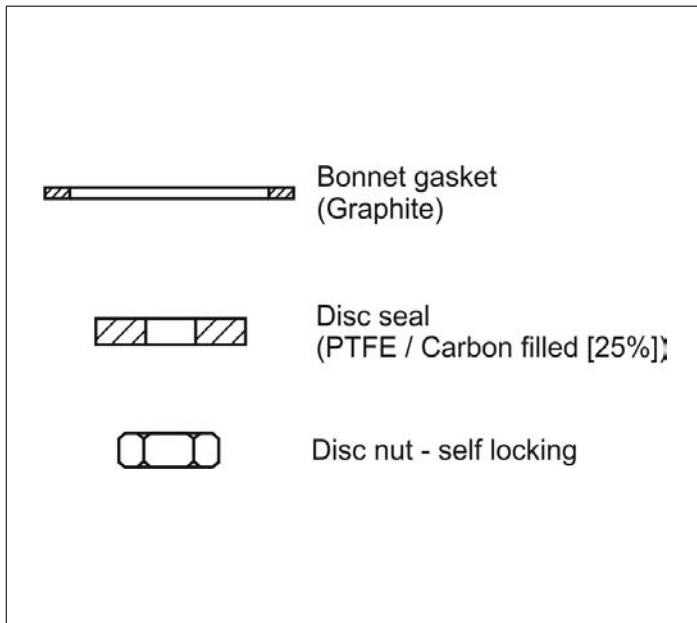

Type 30714	Technical data										
Nominal size	DN	10	15	20	25	32	40	50	65	80	100
Dimension code	.X.	0100	0150	0200	0250	0320	0400	0500	0650	0800	1000
Weight	ca. kg	0.02	0.02	0.03	0.04	0.06	0.07	0.11	0.16	0.22	0.30

Dimensions in mm.

Nonferrous materials

DIN EN new		DIN old		ASTM
CC490K	CuSn3Zn8Pb5-C	RG2	2.1098	-
CC491K	CuSn5Zn5Pb5-C	RG5	2.1096.01	B 62 UNS C83600
CC493K	CuSn7Zn4Pb7-C	RG7	2.1090	B 505 UNS C93200
CW450K	CuSn4	CUSN4	2.1016	B 103 UNS C51100
CW452K	CuSn6	CUSN6	2.1020	B 159 UNS C51900
CW453K	CuSn8	CUSN8	2.1030	B 103 UNS C52100
CW507L	CuZn36	CUZN36	2.0335	B 111 UNS C27000
CW508L	CuZn37	CUZN37	2.0321	B 111 UNS C27200
CW509L	CuZn40	CUZN40	2.0360	B 111 UNS C28000
CW610N	CuZn39Pb0,5	CUZN39PB	2.0372	B 111 UNS C36500
CW612N	CuZn39Pb2	MS58	2.0380.10	B 283 UNS C37770
CW614N	CuZn39Pb3	MS58	2.0401.08	B 283 UNS C38500
CW617N	CuZn40Pb2	MS58	2.0402.20	B 283 UNS C38000
CW710R	CuZn35Ni3Mn2AlPb	CUZN35NI	2.0540	-
CW713R	CuZn37Mn3Al2PbSi	CUZN40AL	2.0552	-
CW718R	CuZn39Mn1AlPbSi	CUZN40AL	2.0561	-
CW720R	CuZn40Mn1Pb1	CUZN40MN	2.0580	-
CW723R	CuZn40Mn2Fe1	CUZN40MN	2.0572	-

Ferrous materials

DIN EN new		DIN old	ASTM
1.1200	Spring steel	Carbon steel	A 227
1.4021	C20Cr13	1.4021	A 276 Grade 420
1.4034	X45Cr13	1.4034	A 276 Grade 420
1.4057	X17CrNi16-2	1.4057	A 276 Grade 431
1.4104	X14CrMoS17	1.4104	A 276 Grade 430F
1.4112	X90CrMoV18	1.4112	A 276 Grade 440B
1.4122	X39CrMo17-1	1.4122	-
1.4300	X12CrNi18-8	1.4300	A 276 Grade 302
1.4301	X5CrNi18-10	1.4301	A 276 Grade 304
1.4305	X8CrNiS18-9	1.4305	A 276 Grade 303
1.4306	X2CrNi19-11	1.4306	A 312 TP 304L
1.4308	G-X6CrNi18-9	1.4308	A 351 CF8
1.4310	X10CrNi18-8	1.4310	A 313 Grade 301
1.4401	X5CrNiMo17-12-2	1.4401	A 276 Grade 316
1.4404	X2CrNiMo17-12-2	1.4404	A 276 Grade 316L
1.4408	GX5CrNiMo19-11-2	1.4408	A 351 CF 8M
1.4409	G-X2NiCrMo28-20-2	1.4409	A 351 CF 3M
1.4541	X6CrNiTi18-10	1.4541	A 276 Grade 321
1.4568	X7CrNiAl17-7	1.4568	A 313 Grade 631
1.4571	X6CrNiMoTi17-12-2	1.4571	A 313 Grade 316Ti
1.4552	G-X7CrNiNb18-9	1.4552	A 351 CF 8C
1.4923	X22CrMoV12-1	1.4923	A 193 Grade B6
1.4980	X5CrNiTi26-15	1.4980	A 286 Grade 660
1.5415	16Mo3	-	A 182 Grade F1
1.7225	42CrMo4	1.7225	A 194 Grade 7
1.7258	24CrMo5	1.7258	A 194 Grade B7
1.7335	13CrMo4-5	1.7335	A 182 Grade F12
1.7380	10CrMo9-10	1.7380	A 182 Grade F22
1.7709	21CrMoV5-7	1.7709	-

Dimensions of DIN flanges



DN = Nominal diameter
D = Diameter of flange
Lk = Diameter of bolt circle
n = Number of holes
d = Diameter of holes

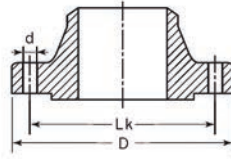

DN		PN 6				PN 10				PN 16				PN 25				PN 40			
		D	Lk	n	d	D	Lk	n	d	D	Lk	n	d	D	Lk	n	d	D	Lk	n	d
10	3/8"	75	50	4	11	90	60	4	14	90	60	4	14	90	60	4	14	90	60	4	14
15	1/2"	80	55	4	11	95	65	4	14	95	65	4	14	95	65	4	14	95	65	4	14
20	3/4"	90	65	4	11	105	75	4	14	105	75	4	14	105	75	4	14	105	75	4	14
25	1"	100	75	4	11	115	85	4	14	115	85	4	14	115	85	4	14	115	85	4	14
32	1-1/4"	120	90	4	14	140	100	4	18	140	100	4	18	140	100	4	18	140	100	4	18
40	1-1/2"	130	100	4	14	150	110	4	18	150	110	4	18	150	110	4	18	150	110	4	18
50	2"	140	110	4	14	165	125	4	18	165	125	4	18	165	125	4	18	165	125	4	18
65	2-1/2"	160	130	4	14	185	145	4	18	185	145	4	18	185	145	8	18	185	145	8	18
80	3"	190	150	4	18	200	160	8	18	200	160	8	18	200	160	8	18	200	160	8	18
100	4"	210	170	4	18	220	180	8	18	220	180	8	18	235	190	8	22	235	190	8	22
125	5"	240	200	8	18	250	210	8	18	250	210	8	18	270	220	8	26	270	220	8	26
150	6"	265	225	8	18	285	240	8	22	285	240	8	22	300	250	8	26	300	250	8	26
200	8"	320	280	8	18	340	295	8	22	340	295	8	22	360	310	12	26	375	320	12	30

DN		PN 63				PN 100				PN 160				PN 250				PN 320			
		D	Lk	n	d	D	Lk	n	d	D	Lk	n	d	D	Lk	n	d	D	Lk	n	d
10	3/8"	100	70	4	14	100	70	4	14	100	70	4	14	125	85	4	18	125	85	4	18
15	1/2"	105	75	4	14	105	75	4	14	105	75	4	14	130	90	4	18	130	90	4	18
20	3/4"	-	-	-	-	-	-	-	-	-	-	-	-	-	-	-	-	-	-	-	-
25	1"	140	100	4	18	140	100	4	18	140	100	4	18	150	105	4	22	160	115	4	22
32	1-1/4"	-	-	-	-	-	-	-	-	-	-	-	-	-	-	-	-	-	-	-	-
40	1-1/2"	170	125	4	22	170	125	4	22	170	125	4	22	185	125	4	26	195	145	4	26
50	2"	180	135	4	22	195	145	4	26	195	145	4	26	200	150	8	26	210	160	8	26
65	2-1/2"	205	160	4	22	220	170	8	26	220	170	8	26	230	180	8	26	255	200	8	30
80	3"	215	170	4	22	230	180	8	26	230	180	8	26	255	200	8	30	275	220	8	30
100	4"	250	200	4	22	265	210	8	30	265	210	8	30	300	235	8	30	300	265	8	36

Dimensions of ANSI flanges

- DN** = Nominal diameter
- D** = Diameter of flange
- Lk** = Diameter of bolt circle
- n** = Number of holes
- d** = Diameter of holes
- B** = Flange bore
- A_n** = Outside diameter butt weld

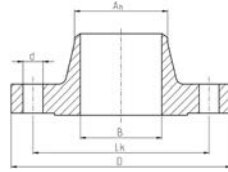

				Class 150				Class 300			
DN		B	A _n	D	Lk	n	d	D	Lk	n	d
15	1/2"	15.8	21.3	90	60.3	4	15.9	95	66.7	4	15.9
20	3/4"	20.9	26.7	100	69.9	4	15.9	115	82.6	4	19.0
25	1"	26.6	33.4	110	79.4	4	15.9	125	88.9	4	19.0
32	1-1/4"	35.1	42.2	115	88.9	4	15.9	135	98.4	4	19.0
40	1-1/2"	40.9	48.3	125	98.4	4	15.9	155	114.3	4	22.2
50	2"	52.5	60.3	150	120.7	4	19.1	165	127.0	8	19.0
65	2-1/2"	62.7	73.0	180	139.7	4	19.1	190	149.2	8	22.2
80	3"	77.9	88.9	190	152.4	4	19.1	210	168.3	8	22.2
100	4"	102.3	114.3	230	190.5	8	19.1	255	200.0	8	22.2
125	5"	128.2	141.3	255	215.9	8	22.2	280	235.0	8	22.2
150	6"	154.1	168.3	280	241.3	8	22.2	320	269.9	12	22.2
200	8"	202.7	219.1	345	298.5	8	22.2	380	330.2	12	25.4

Standard pipe dimensions, available pipe dimensions



- x = Standard pipe dimensions**
- o = available on request**
- = not available resp. project specified option**

Stainless steel and copper pipes

DIN EN ISO 1127 - Stainless steel pipe dimensions									
Wall thicken. in mm	outside pipe diameter in mm								
	10.0	12.0	17.2	21.3	26.9	33.7	42.4	48.3	60.3
1.0	x	x	-	-	-	-	-	-	-
1.6	-	-	-	o	-	-	-	-	-
2.0	-	o	-	o	-	o	x	o	o
2.3	-	-	x	-	-	-	-	-	-
2.6	-	-	-	x	-	o	-	o	-
2.9	-	-	-	-	x	-	-	-	-
3.2	-	-	-	o	-	x	o	-	-
3.6	-	-	-	-	-	-	-	x	x
4.5	-	-	-	-	-	o	-	-	-

ASTM A312 - Stainless steel pipe dimensions									
Wall thickness	outside pipe diameter in mm								
	1/4"	3/8"	1/2"	3/4"	1"	1-1/4"	1-1/2"	2"	
	13.72	17.15	21.34	26.67	33.40	42.16	48.26	60.33	
Sch. 5	1.20	1.20	1.72	1.72	1.72	1.72	1.72	1.72	
Sch. 10	1.72	1.72	2.11	2.11	2.77	2.77	2.77	2.77	
Sch. 40	2.24	2.31	2.77	2.87	3.38	3.56	3.68	3.91	

DIN EN 12449 - Copper pipe dimensions									
Wall thicken. in mm	outside pipe diameter in mm								
	10.0	12.0	15.0	18.0	22.0	28.0	35.0	42.0	54.0
1.0	x	x	o	-	-	-	-	-	-
1.5	-	-	x	x	x	x	x	x	-
2.0	-	-	-	-	-	-	-	-	x



Standard pipe dimensions, available pipe dimensions



- x = Standard pipe dimensions
- o = available on request
- = not available resp. project specified option

Stainless steel body - welding connections

DIN EN ISO 1127 - Butt weld connection											
Wall thckn. in mm	outside pipe diameter in mm										
	12.0	13.5	15.0	16.0	17.2	18.0	21.3	22.0	26.9	28.0	30.0
1.0	x	-	-	-	-	-	-	-	-	-	-
1.5	-	-	x	x	-	-	-	-	-	o	-
1.6	-	x	-	-	x	o	o	-	o	o	-
2.0	o	-	-	-	o	o	x	o	x	o	x
2.3	-	o	-	-	o	-	-	-	o	-	-
2.6	-	-	-	-	-	-	o	-	o	-	-
2.9	-	-	-	-	-	-	-	-	o	-	-
3.2	-	-	-	-	-	-	o	-	-	-	-
3.6	-	-	-	-	-	-	-	-	-	-	-
4.0	-	-	-	-	-	-	-	-	-	-	-
5.6	-	-	-	-	-	-	-	-	-	-	-
6.3	-	-	-	-	-	-	-	-	-	-	-
7.1	-	-	-	-	-	-	-	-	-	-	-

DIN EN ISO 1127 - Butt weld connection											
Wall thckn. in mm	outside pipe diameter in mm										
	33.7	38.0	42.4	48.3	60.3	70.0	76.1	88.9	114.3	168.3	219,1
1.0	-	-	-	-	-	-	-	-	-	-	-
1.5	-	-	-	-	-	-	-	-	-	-	-
1.6	o	-	-	o	o	-	-	-	-	-	-
2.0	x	x	-	x	o	o	-	-	-	-	-
2.3	-	-	-	-	-	-	-	o	-	-	-
2.6	o	-	x	o	x	-	x	-	-	-	-
2.9	-	-	-	-	o	x	o	-	x	-	-
3.2	o	-	-	o	-	-	-	x	-	o	-
3.6	-	-	-	o	-	-	o	-	-	-	-
4.0	-	-	-	-	o	-	-	o	-	-	x
5.6	-	-	-	-	-	-	-	o	-	-	-
6.3	-	-	-	-	-	-	-	-	o	-	-
7.1	-	-	-	-	-	-	-	-	-	x	-

ASTM A312 - Butt weld connection													
Wall thckn.	outside pipe diameter in mm												
	1/4"	3/8"	1/2"	3/4"	1"	1-1/4"	1-1/2"	2"	2-1/2"	3"	4"	6"	8"
	13.72	17.15	21.34	26.67	33.40	42.16	48.26	60.33	73.03	88.90	114.3	168.3	219.1
Sch. 5	1.20	1.20	1.72	1.72	1.72	1.72	1.72	1.72	2.11	2.11	2.11	2.77	2.77
Sch. 10	1.72	1.72	2.11	2.11	2.77	2.77	2.77	2.77	3.04	3.04	3.04	3.38	3.76
Sch. 40	2.24	2.31	2.77	2.87	3.38	3.56	3.68	3.91	5.16	5.49	6.02	7.11	8.18



CERTIFICATE



Management system as per
DIN EN ISO 9001 : 2008

In accordance with TÜV NORD CERT procedures, it is hereby certified that

HEROSE GMBH
ARMATUREN UND METALLE
Elly-Heuss-Knapp-Straße 12
23843 Bad Oldesloe
Germany



with the site **HEROSE Valves Co., Ltd., Building 18, JinGang Industry Park,
Dalian Economy & Technology Development Park No. 49, Dalian 116600, China**

applies a management system in line with the above standard for the following scope

**Development, Manufacture and Sales of
Industrial Valves and Pressure Safety Valves**

Certificate Registration No. 78 100 023710
Audit Report No. 3513 7037

Valid until 2017-08-14
Initial certification 2002

Kaas
Certification Body
at TÜV NORD CERT GmbH

Essen, 2014-08-15

This certification was conducted in accordance with the TÜV NORD CERT auditing and certification procedures and is subject to regular surveillance audits.

TÜV NORD CERT GmbH

Langemarckstrasse 20

45141 Essen







www.tuev-nord-cert.com



TGA-ZM-07-06-00

Nowadays, product approvals are essential for many customer applications. Below is an excerpt of our most important certifications. A detailed list can be found at herose.com.

Type approvals

Approval company	Approval	Mark
TÜV	CE LNG (DIN EN 12567) Firesafe (DIN EN ISO 10497)	
National Board	ASME / UV	
AQSIQ	CCC	
DIN GOST TÜV	EAC	
TSSA	CRN	
AAR		

Classification societies



Bureau
Veritas



China
Classification
Society



Det Norske Veritas/
Germanischer
Lloyd



Lloyd's Register



Russian Maritime
Register of
Shipping

Overview ASME Approvals

Safety Valves



HEROSE Type	Inlet	D ₀	Certificate No.	Media
06383/ 06388/ 06413/ 06418	1/2" up to 3/4"	7 mm	91011	Vapours and Gases
06383/ 06388/ 06413/ 06418	1/2" up to 3/4"	10.5 mm	91088	Vapours and Gases
06383/ 06388/ 06413/ 06418	1"	15 mm	91077	Vapours and Gases
06383/ 06388/ 06413/ 06418	1-1/4" up to 1-1/2"	23 mm	91101	Vapours and Gases



General notes on application, types and identification of safety valves

Application: A safety valve is a valve which opens automatically to prevent a predetermined gauge pressure being exceeded and which recloses after decrease in pressure.

Definitions: DIN EN ISO 4126-1 und AD 2000 Merkblatt A2 specifies different types and terms for safety valves. Please see below an extract of this standard.

Standard safety valve: A standard safety valve is a valve which, following opening, reaches the degree of lift necessary for the mass flow to be discharged within a pressure rise of not more than 10%. No further requirements are made for the opening characteristics.

Full lift safety valve: A full lift safety valve is a valve which, after commencement of lift, opens rapidly within a 5% pressure rise up to the full lift as limited by the design. The amount of lift up to the rapid opening (proportional range) shall not be more than 20% of the total lift.

Set pressure: The set pressure is the gauge pressure at which under operating conditions direct loaded safety valves commence to lift.

Test pressure: The test pressure is the gauge pressure at which under test stand conditions (atmospheric back pressure) direct loaded safety valve commence to lift.

Opening pressure: The opening pressure is the gauge pressure at which the lift is sufficient to discharge the predetermined flowing capacity; it is equal to the set pressure plus opening pressure difference.

Reseating pressure: The reseating pressure is the gauge pressure at which the direct loaded safety valve is reclosed.

Marking of type tested safety valves

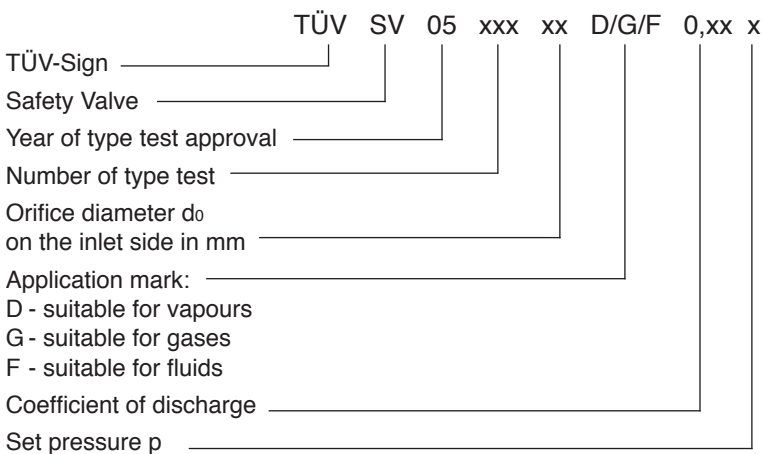

Safety Valves

Advice for installing



Advice for installing of safety valves

Special care is necessary when installing the safety valves in order to ensure the proper functioning of the valve.

Please note the following instructions carefully:

1. Safety valves should not be handled roughly during the transport, storage or assembly, e.g. using unsuitable tools.
2. Care should be taken that foreign bodies do not enter the valve. For this reason the plastic caps covering the connection openings should be removed directly before assembly.
3. Spring loaded safety valves are to be connected in such a way that the spring cap is placed standing vertically upwards.
Spring loaded safety valves, which implies the note „suitable for horizontal installation“ can be assembled in horizontal position. The outlet flow direction has to be top down then.
4. The connecting piping must be free from dirt, rust, welding slag and other foreign bodies.
5. In the case of safety valves with female thread the connection pipes or fittings should not be screwed too deeply into the housing. No sealing material is allowed to enter the valve.
6. The blow-off pipes must be set at a descending gradient in order that the collection of the substance flowing through is avoided, and no condensation or sweating accumulation takes places in the body of the valve.
7. The lifting device should only be set in operation when operating pressure is switched on.
8. Adjustments to the test pressure of the valves, subject to governmental regulations, should only be done in our works or under the supervision of the responsible control authorities.



Safety Valves

Advice for ordering



Advice for ordering of safety valves

Ordering safety valves please declare additional to Part No. and dimension the following informations:

- type of the medium
- temperature of medium
- set pressure

All orders are subject to our conditions of Sale 07/2014.

Design and materials

All rights are reserved for design changes, e.g. upon entering force of new regulations, and for the use of other, equivalent materials.

Illustrations, weights and measures are without obligation.

The following Conditions shall apply for all purchase contracts and contracts for work and services between us and our commercial contract partners (hereinafter referred to as: the Customer) as well as for our offers, even if we do not explicitly refer to these in individual cases. Deviations from these shall only be binding for us if we have explicitly confirmed this in writing. The Customer's purchasing terms and conditions shall not be binding for us, even if we do not explicitly object to these.

1. Offer and conclusion of order

Our offer remains non-binding with regard to the price, quantity, delivery data and possibility of delivery until the order has been confirmed in writing. Ancillary agreements shall only be effective if we have confirmed these in writing.

2. Scope of delivery

The scope of delivery is finalised in the confirmation of the order. For goods which are not catalogue items, a tolerance in the quantity of 10% more or less items is permitted.

3. Delivery and delivery periods

The delivery period commences when all details of the order have been confirmed, however not until the fulfilment of the Customer's contractual obligations. The delivery period shall be deemed to have been completed if the goods have left the warehouse prior to its expiry, or, if dispatch is delayed for reasons for which the Customer is responsible, with the notification of readiness for dispatch within the agreed delivery period.

Compliance with the delivery period is conditional on correct and timely deliveries to us.

Partial deliveries which are in good time and in suitable quantities are permissible and can be invoiced separately.

If the fulfilment of our obligation for delivery is prevented by force majeure, labour disputes or other events which are not within our sphere of influence - regardless of whether these occur with us or our sub-suppliers - the fulfilment of our obligation for delivery shall be extended for the duration of the disturbance. If delivery is rendered impossible due to such an event, or is not reasonable for one of the parties, both parties shall be entitled to withdraw. In case of arrears or impossibility of delivery for which we are responsible, the customer shall be entitled to withdraw the order according to the statutory conditions. Art. 14 of these Terms and Conditions shall apply in the case of claims for compensation.

If dispatch is delayed at the wish of the customer, commencing one month after notification of readiness for delivery, the costs which are incurred due to storage, however at least 1% of the invoiced amount shall be invoiced to the customer.

4. Prices

All prices are ex stock plus the statutory VAT. The prices which are valid on the day of delivery apply. Packaging, loading costs, customs duties etc. shall be borne by the customer.

5. Shipping

Dispatch and shipping of the goods shall be at the account and risk of the customer.

6. Transfer of risk

The risk shall be transferred to the customer as soon as the goods have left our company. If the dispatch of the goods is delayed due to the customer, the risk shall be transferred with the notification of readiness for delivery.

7. Terms of payment

The invoiced amounts are payable in cash within 14 days after the date of the invoice with 2% discount of the net value of the goods, or within 30 days without deduction. Discounts may not be deducted for new invoices, as long as older invoices which are due for payment have not been settled.

In case of arrears or for the time of deferment of receivables, the statutory interest on arrears shall be charged, regardless of any further claims for compensation. If it becomes apparent subsequent to the conclusion of the contract that our claim for payment is endangered by lack of solvency on the part of the Customer, all of our outstanding invoices shall become due for payment immediately. In this case, we shall be entitled to make outstanding deliveries conditional on cash payment or the provision of a security. Any further statutory claims shall remain unprejudiced by this. Offsetting is only permissible with regard to undisputed or legally established counterclaims. The Customer is only entitled to exercise a right of retention if the claim is based on the same contractual relationship.

The same shall apply for the retention of payments.

8. Reservation of title

Goods which have been delivered remain our property until payment of all of our outstanding claims, including ancillary costs and interest. This shall also apply to the cashing of cheques for payment of such claims. In case of current accounts, the reservation of title is deemed to be security for our balance claim. Modification or processing of the goods subject to reservation of title shall be performed on our behalf, without this giving rise to any obligations for us.

In the case of processing, combination or mixing of our goods with other goods which are not our property, we shall be entitled to co-ownership of the new goods in the relationship of the invoice value of the goods subject to reservation of title to the value of the other processed goods at the time of processing, combination or mixing. If the Customer obtains the sole ownership of the new goods, he herewith transfers co-ownership of the new goods in the relationship of the other processed goods at the time of processing, combination or mixing and shall keep the said goods on our behalf with due business diligence.

Resale of the delivered goods, regardless of whether these are unprocessed, or have been processed, combined or mixed is only permitted in the normal course of business with reservation of title, and only then, if the claims resulting from the resale are ceded to us. The Customer is prohibited from pledging or transferring the goods as security, as is the agreement of a prohibition of assignment and an assignment without our consent in the context of factoring. The Customer shall inform us without delay in case of seizure or any other impairment of our entitlements by third parties. The Customer hereby assigns to us in advance, all claims to which he is entitled now or at a later date from the resale or for whatever legal reason with regard to the goods which we have delivered. We accept the said assignment. The value of the goods subject to reservation of title is our invoice amount plus a security surcharge of 10%, which however remains without effect if this is precluded by the rights of third parties. In the case of resale of our goods after processing, combination or mixing, or the resale of the new goods which result from processing, combination or mixing, the claim against the Customer's buyer shall be assigned to the amount of the invoice value of our processed, combined or mixed goods. This shall also apply in the case of resale after our goods have become an essential part of another good after combination or processing with other goods which are not our property. If the value of the securities which are provided to us exceeds a total of 10%, we shall be obliged to release securities of our choice if so requested by the Customer. With the payment of our claims, ownership of the goods subject to reservation of title and the assigned claims shall be transferred to the Customer. Until this is revoked by us, the Customer is entitled to collect the purchase price on our behalf. On demand, the Customer shall be obliged to notify the assignment to his buyer and to provide the necessary information and to surrender the documents which are necessary for us to enforce our claims against the said buyer.

10. Liability for defects

The warranty rights of the Customer are conditional on him having fulfilled his obligations for examination and complaint according to Art 377 HGB (German Commercial Code).

Increases or reductions in weight due to the casting process do not entitle the Customer to complain. If the item being purchased is defective, we can remedy the defect or deliver a replacement, at our discretion. If we remedy the defect, we shall bear all expenses necessary to remedy the defect, especially the costs of transport, travel, work and material unless they are increased due to the fact that the item being purchased was taken to a place other than the place of performance. The Customer may withdraw from the contract or demand a reduction if after having been set a reasonable period of grace we fail to provide a subsequent delivery or correction, if correction has finally failed, if we refuse the said correction or if this is unreasonable to the Customer. If there is only an insignificant fault and the goods can be utilised by the Customer without disadvantage, he is only entitled to a reduction in the purchase price.

For new products, the warranty period is 1 year from the date of delivery. No warranty is assumed for used products. The period of limitation in case of a delivery recourse according to Art. 478, 479 BGB is not affected by the regulations of the two previous provisions. Compensation claims due to an injury to life, limb or health which are due to a fault, or according to product liability law are also not restricted by the aforementioned regulations. Other claims for compensation under warranty law are also not restricted by this regulation in the case of gross negligence, wilful action or breach of major contractual obligations. Clause 14 of these Terms and Conditions applies.

11. Return delivery

Return deliveries which are not based on a legal claim may only be made with carriage paid with our explicit consent. As compensation for the costs which we incur for any return delivery, we reserve the right to an appropriate deduction from the net value of the goods in the credit note of at least 20% of the net value of the goods.

12. Catalogues

Illustrations in our catalogues and brochures are not binding with regard to the design. We reserve the right to changes to the design, insofar as these is necessary for technical reasons and do not impair the purpose of the contract. Deviations from the specified dimensions and weights are permissible, if the said do not impair the contractual purpose and quality.

13. Copyright

We reserve ownership and copyright for catalogues, illustrations, drawings, samples and other documents. These may not be made accessible to third parties without our consent and must be returned to us immediately on demand. If an order which is placed with us on the basis of submitted drawings or models infringes against third party patent rights, design rights or trademarks, the Customer shall bear all responsibility for this and shall be liable to us for any claims for damages or loss of profit and shall indemnify us against any claims by third parties, unless he is not responsible for the infringement.

14. General liability

We shall only be liable in the case of wilful action or gross negligence. In the case of a breach of major contractual obligations we shall also be liable for simple negligence. Major contractual obligations are those, whose fulfilment enables the proper fulfilment of the contract and on whose fulfilment the purchaser may normally rely and does rely. Except for the case of wilful intent, our liability shall be restricted to damage which is typical for the contract and which is reasonably foreseeable.

The aforementioned limitation of liability shall not apply in the case of injury to life, limb or health and in cases of liability under product liability laws.

The Customers claims for the compensation of expenses pursuant to Section 284 BGB are excluded to the extent that the claim for damages in lieu of performance is excluded pursuant to the foregoing provisions. The aforementioned restriction of liability shall also apply in favour of our employees, bodies and other agents.

15. Place of performance, place of jurisdiction, applicable law, miscellaneous

The place of performance for all claims arising from this contract is our registered office. The place of jurisdiction for all disputes with businessmen, legal entities under public law or special funds under public law, or with persons who do not have a general jurisdiction in Germany, is our registered office. However, we are entitled to bring an action against the Customer at the Customers registered place of business.

These Conditions shall be governed by the laws of the Federal Republic of Germany to the exclusion of the UN Convention of the International Sale of Goods (CISG).

CRYOGENIC



Globe valves, control valves, check valves and fillsystems for Cryogenic Service

Media: liquefied gases such as oxygen, nitrogen, argon, krypton and LNG
 Sizes: DN10 (3/8") to DN50 (2") (gunmetal/brass)
 DN10 (3/8") to DN200 (8") (stainless steel)
 Temperature: -255°C (-427°F) to +120°C (+248°F)
 Pressure: up to 50 bar (725 psi)



Safety valves for Cryogenic Service

Media: liquefied gases such as oxygen, nitrogen, argon, carbon dioxide and LNG
 Sizes: DN6 (1/4") to DN50 (2")
 Temperature: -270°C (-454°F) to +400°C (+752°F)
 Pressure: 0.2 bar (3 psi) to 250 bar (3626 psi)

INDUSTRY



Safety valves for gases, vapours and fluids

Media: Gases, vapours, fluids, liquefied gases, refrigerants and dusty media
 Sizes: DN6 (1/4") to DN50 (2")
 Temperature: -270°C (-454°F) to +400°C (+752°F)
 Pressure: 0.2 bar (3 psi) to 250 bar (3626 psi)



DIN EN valves made of gunmetal/brass

Media: non-flammable and non-toxic fluids, gases and vapours
 Sizes: DN6 (1/4") to DN150 (6")
 Temperature: -10°C (+14°F) to +200°C (+392°F)
 Pressure: up to 16 bar (232 psi)

ENERGY



Drain valves, three-way valves, ball valves and gate valves for oil-immersed transformers

Media: Transformer oil
 Sizes: DN15 (1/2") to DN250 (10")
 Temperature: -50°C (-58°F) to +120°C (+248°F)
 Pressure: up to 16 bar (232 psi)

HEROSE GMBH
ARMATUREN UND METALLE

Elly-Heuss-Knapp-Strasse 12
23843 Bad Oldesloe
Germany

Phone: +49 4531/509-0
Fax: +49 4531/509-120
info@herose.com

