

HEMA



VIEWING SYSTEMS

MACHINE SAFETY WINDOWS
INTEGRATED LED LIGHTING

SPINVISTA SPIN WINDOWS

WE ARE THERE FOR YOU WORLDWIDE

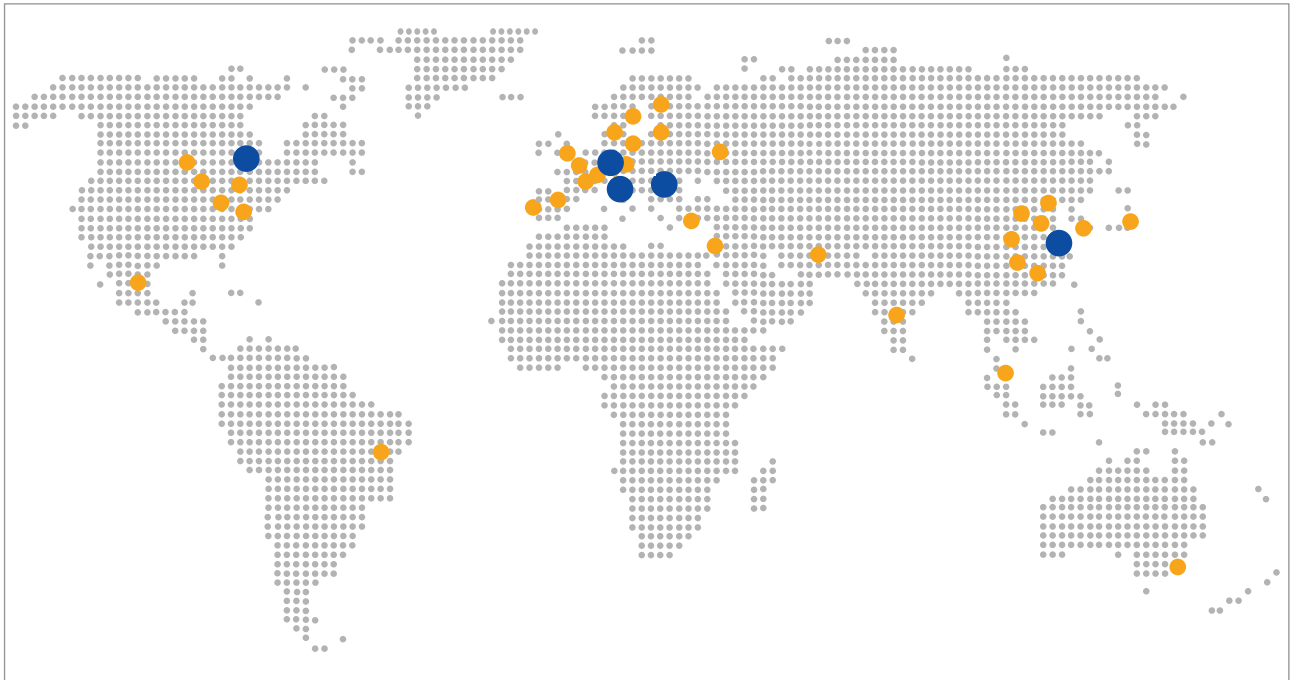

NORTH & SOUTH AMERICA

HEMA North America, Inc.
St. Catharines, Ontario, L2S 0B5, Canada
Phone +1 289 868 8778
Fax +1 888 480 3273
E-Mail info@hema-northamerica.com



HEADQUARTER

HEMA Maschinen- und Apparateschutz GmbH
63500 Seligenstadt, Germany
Phone + 49 6182 773-0
Fax + 49 6182 773-35
E-Mail info@hema-group.com



ASIA

HEMA ZHAO Protection Technology
(Qingdao) Co., Ltd.
26611 Qingdao, Chengyang District, China
Phone + 86 532 879 633 02
Fax + 86 532 879 623 57
E-Mail info@hemazhao.com



EUROPE SOUTH

HEMA SEFRA S.r.l.
Terre del Reno - Fraz. Sant'Agostino
44047 Sant'Agostino (FE), Italy
Phone + 39 0532 186 8344
Fax + 39 0532 186 8340
E-Mail hema-sefra@hema-group.com



EUROPE EAST

Advantage HEMA Innovation Technologies S.r.l.
310375 Arad, Romania
Phone + 40 371 408 001
Fax + 40 372 8765 64
E-Mail advantage-hema@hema-group.com

CONTENT

MACHINE SCHINENSICHERHEITSSCHEIBEN	
Modular Concept Machine Safety Windows and SPINVISTA Spin Windows	Page 4
Machine Safety Windows	Page 5
Impact tests Machine Safety Windows	Page 6
Machine Safety Windows	Page 8
Machine Safety Windows with integrated lighting	Page 10
SRIW Panel with Perlucor	Page 11
SPINVISTA SPIN WINDOWS	
SPINVISTA Spin windows	Page 11
SPINVISTA EVO	Page 14
SPINVISTA NEO	Page 15

CONTENT	03
SAFETY WINDOWS	04
SPINVISTA SPIN WINDOWS	12

FURTHER INFORMATION

CATALOGUE PROTECTION SYSTEMS

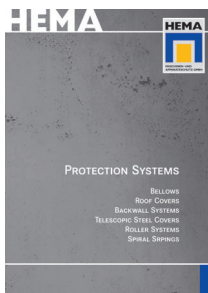

- Bellows
- Roof Cover
- Backwall Systems
- Telescopic Steel Covers
- Roller Covers
- Spiral Springs

CATALOGUE CLAMPING AND BRAKING SYSTEMS

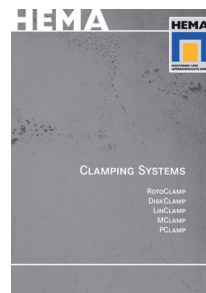

- RotoClamp
- DiskClamp
- LinClamp
- MClamp
- PClamp

MODULAR CONCEPT

03	CONTENT
04	SAFETY WINDOWS
11	SPINVISTA SPIN WINDOWS

MACHINE SAFETY WINDOWS

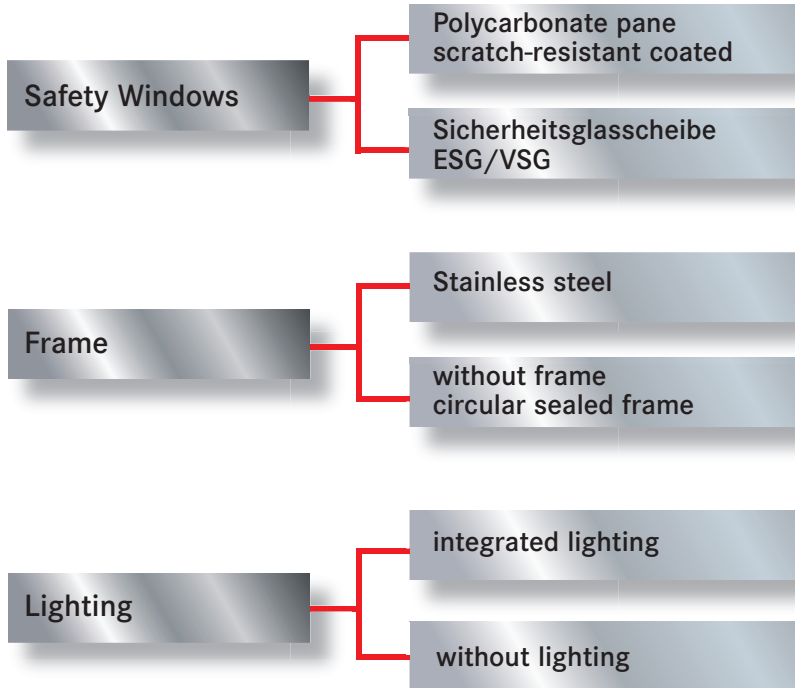

SPINVISTA SPIN WINDOWS

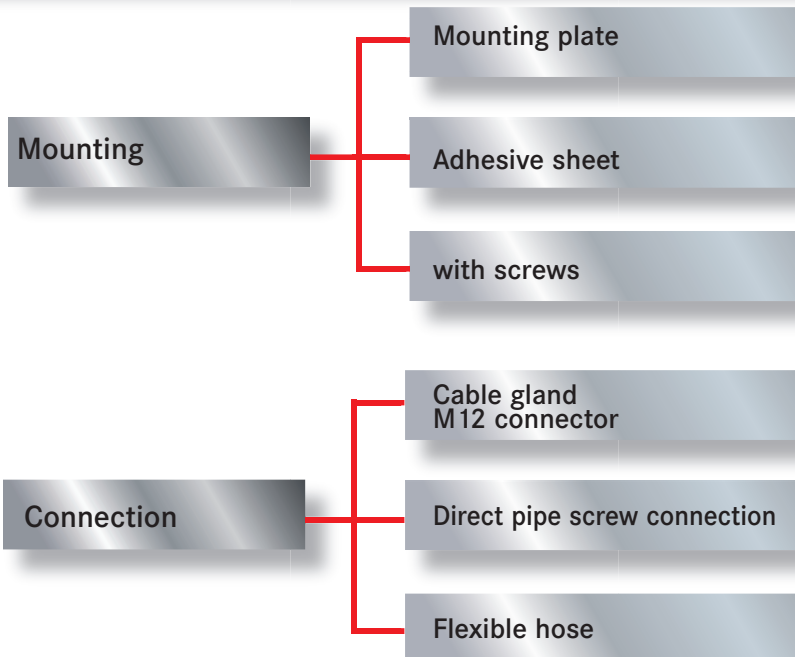

MACHINE SAFETY WINDOWS

Machine safety windows are restraining protective devices on machining centres. They prevent tools, machined parts and broken particles from being ejected out of the machine's working space and protect people from injuries. Industrial accident statistics show that workers are still the frequent victims of flying objects ejected by machine tools.

Viewing panes in machining centres, ideally combined with a spin window system, provide a good view for the operator and transparency of the manufacturing process. Viewing panes within the trajectory path of parts must exhibit adequate strength. According to the latest empirical tests polycarbonate is the material best suited for safety glass owing to its high energy absorption.

Application	Protection against
Turning	<ul style="list-style-type: none"> ■ broken chuck components ■ broken tools ■ machine parts
Milling	<ul style="list-style-type: none"> ■ hot chips ■ broken tools ■ loose machine parts
Grinding	<ul style="list-style-type: none"> ■ Pieces of broken grinding disks

Application areas of safety windows

The restraining capacity of a polycarbonate pane of 8 mm thickness is about the same as of a 3 mm St 12.03 steel sheet.

A disadvantage of polycarbonate is its sensitivity to scratching and it will be damaged by the impact of hot chips and sparks. Furthermore it has low resistance to the effects of coolants, grease and oil and will embrittle as a result. This can reduce the restraining capacity significantly within just a few years.

The safety glass provided by HEMA is encapsulated and sealed for permanent and efficient protection against these external influences.

Any safety glass showing damage from external mechanical impact, for example cracks, deep scratches or deterioration resulting from exposure to chemicals, must be replaced since its protection function is not guaranteed to its full extend anymore.

The restraining capacity of safety glass depends not only on the thickness of the polycarbonate but also on the sheet metal design of its enclosure. Clamp and adhesive bondings are suitable for the mounting as well as adequate frame solutions.

The joints should be well covered to prevent the screen from being pushed through the frame when impacted by parts.

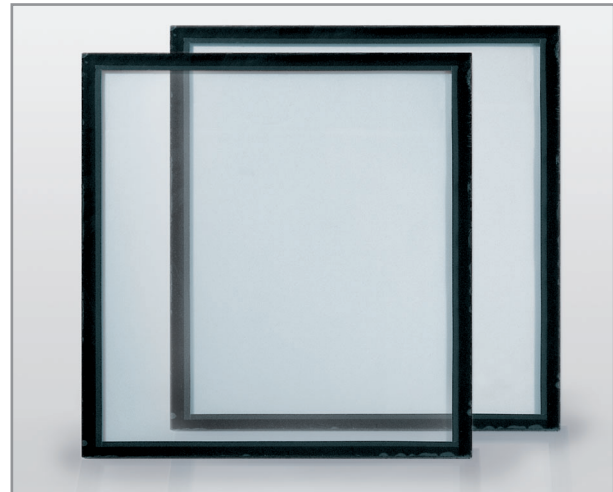

Machine safety window, standard design

Machine safety window »HEMA Window«

The »HEMA Window« machine safety windows are permanently and effectively protected by their encapsulation and sealing against external influencing factors. On the operator side the »HEMA Windows« are coated standardly scratch-resistant. The glass panes to the interior of the machine can optionally be equipped with a scratch resistant Perlucor overlay or with a rotating window.

The machine safety windows and spin window systems were designed in accordance to the standards for tooling machines, DIN EN 23125 for lathes, DIN EN ISO 16089 for stationary grinding machines and DIN EN 12417 for machining centers.



Machine safety window with stainless steel frame, including mounted SPINVISTA

IMPACT TEST

03	CONTENT
06	SAFETY WINDOWS
11	SPINVISTA SPIN WINDOWS

Safety glass is a restraining protective device on machining centres. As part of tests on their restraining ability a range of HEMA polycarbonate panes with and without integrated mounting plate were tested at the IWF of TU Berlin.

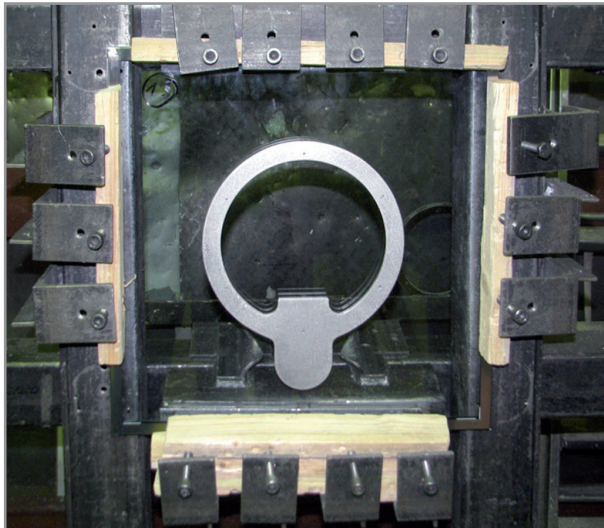

Fixing of pane

For the impact test according to DIN EN 23125, resistance class C3, for example, panes with 10 mm tempered safety glass and 15 mm polycarbonate were tested with and without supporting mountig plate for SPINVISTA.

Testing

Polycarbonate panes are fixed within a frame and impacted with a 2.5 kg projectile.

The speed of the projectile is adjusted at the cannon's pressure, the speed is measured with a double laser light barrier.

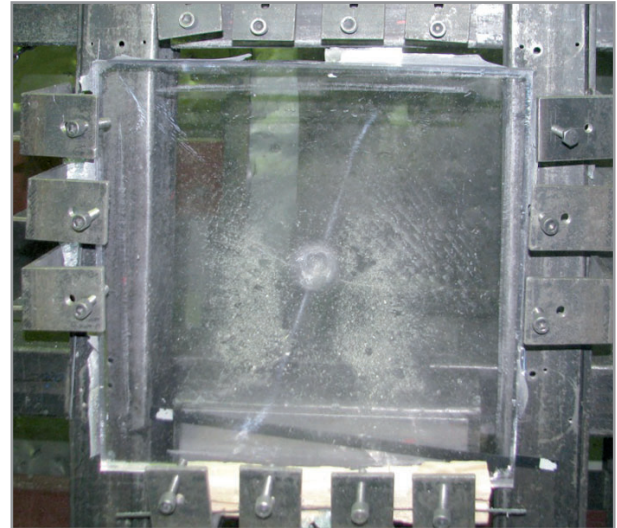

Fixed polycarbonate pane after impact test

Test No	Test objekt	Projectil speed v [m/s]	Projectil enery E [Nm]	Result note
Test 1	4e	80	8,000	passed
Test 2	4b	80	8,000	passed
Test 3	4c	80	8,000	passed
Test 4	4f	80	8,000	passed

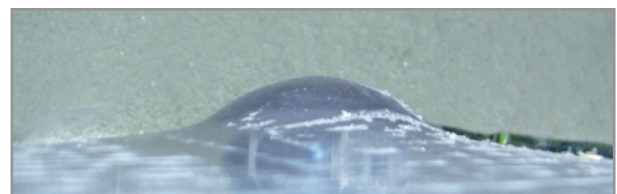

Ident of polycarbonate pane after impact test



Panorama view of test laboratory at the IWF of TU Berlin. In the foreground acceleration pipe with projectile (enlarged).

MACHINE SAFETY WINDOWS

Material/ classification	A1	A2	A3	B1	B2	B3	C1	C2	C3
Mass of projectile in kg	0.625	0.625	0.625	1.25	1.25	1.25	2.50	2.50	2.50
Kinetic energy in joule	320	781	2,000	1,562	2,480	4,000	3,124	4,960	8,000
PC 6 mm	■			■					
PC 8 mm	■	■		■	■		■		
PC 10 mm	■	■	■	■	■		■	■	
PC 12 mm	■	■	■	■	■	■	■	■	
PC 15 mm	■	■	■	■	■	■	■	■	■
PC 19 mm laminated	■	■	■	■	■	■	■	■	■

Impact tests according to DIN EN 23125 at test pattern 500x500 mm

■ Available combination (without guarantee)

max. diameter of clamping jaw Ø (mm)	circumferential speed (m/S)	Projectil dimension D x a (mm x mm)	Projectil mass m (kg)	Impact speed v (m/s)	Impact energy (Nm) up to	Safety classification*	Minimum thickness of PC (mm)
bis 130	25	30 x 19	0,625	32	320	A1	6
	40			50	781	A2	6
	63			80	2,000	A3	8
130 bis 250	40	40 x 25	1,250	50	1,562	B1	6
	50			63	2,480	B2	8
	63			80	4,000	B3	12
über 250	40	50 x 30	2,500	50	3,124	C1	8
	50			63	4,960	C2	10
	63			80	8,000	C3	15

*A1 to C3 = Classification according DIN EN 23125; PK 1 to 5 = classification according to VDW

Parameter for calculation of safety classification and thickness of polycarbonate panes for turning centres according DIN EN 23125

Influencing factors	to be considered in the calculation
Diameter of rotation	■ maximum outer diameter of the clamping jaw at the machine
Rotational speed of the spindle	■ maximum speed of the machine according to the manufacturer
Mass of clamping jaw	■ mass of one clamping jaw (classification according to proposed standard)

MACHINE SAFETY WINDOWS

Calculation of safety classification and required polycarbonate thickness for milling machines DIN EN 16090-1:2018

Influencing factors	bei der Berechnung zu berücksichtigen
Diameter of rotation	■ maximum outer diameter of the cutting tool unit at the machine concerned
Rotation speed of spindle	■ maximum speed of the machine according to the manufacturer
Mass of cutting tool	■ mass of cutting tool, defined for 100 g according to proposed standard

Required Data for calculation of impact energy and impact speed

Projectil mass m (kg)	Impact speed vt (m/s), up to	Impact energy (Nm), bis zu	Mindestdicke Polycarbonat (mm)
0.100	85	361	4
0.100	100	500	6
0.100	120	720	8
0.100	145	1.063	10
0.100	150	1.125	12
0.100	170	1.445	15
0.100	>170	>1.445	19

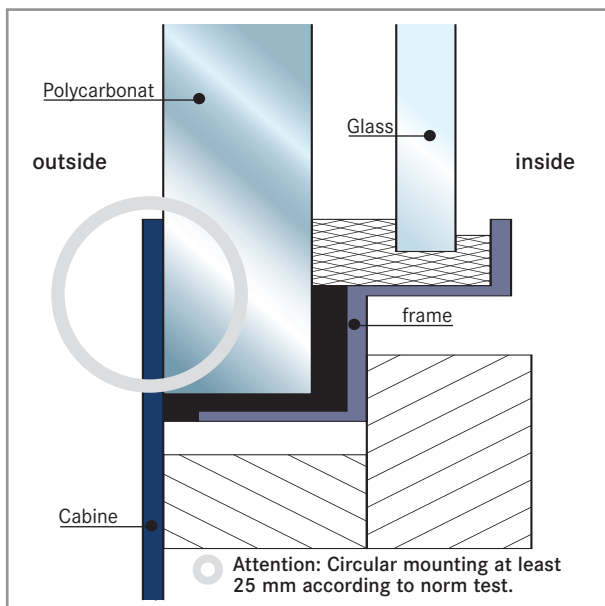

Design of safety glass window

Polycarbonate panes only with safety foil

When exposed these polycarbonate panes may lose their safety restraining properties partly or completely after only a few months of use.

This was impressively demonstrated by tests at the BIA Institute. Systematic research showed that polycarbonate panes splashed with coolant possess a retaining potential of only 60% after nine months of exposure.

According to our definition safety glass may be considered exposed as long as it is not completely encapsulated by an additional glass layer or a special foil. This encapsulation and sealing can be verified only by specialised companies.

In spite of the lower safety classification requirements of milling/drilling machine manufacturers and polycarbonate pane thicknesses less than 6 mm customers still use these panes.

Although the pane thickness corresponds to the machine's safety classification these panes are unprotected, i.e. not encapsulated or sealed.

Polycarbonate panes for machines should be protected against chemical attacks if they are to provide reliable protection over the long term.

A special focus of attention is the safety risks posed by safety windows that has found testimony over recent years.

The replacement of unprotected polycarbonate panes is recommended by VDMA (association of German machine and plant manufacturers) after only two years of use.

The safety glass fulfils the applicable recommendations of VDMA for an assured A1 to C3 safety classification. It is non-aging and resistant to oil, coolants, and heavy impacts.

MACHINE SAFETY WINDOWS

The increasing imports of machining centres from low-cost countries always mean a safety risk, and the legal requirements are not always being met by these products.

Safe operation can be achieved though when these low cost machines are retrofitted in accordance with the required European safety standards.

Recommendation for replacement of panes

According to the recommendations of the German Berufsgenossenschaft BIA (Accident Prevention & Insurance Association), the Werkzeugmaschinenverband VDW, and the IWF/TU Berlin, Fachgebiet Werkzeugmaschinen und Fertigungstechnik, we recommend that protective panes are replaced after 5 years of use.

All buyers of new or second-hand machine tools must be informed of polycarbonate deterioration (e.g. in the manual). It is also recommended to mark the installation date of the polycarbonate pane on the pane itself. Replacing and servicing protection panes must observe all of the instructions from the manufacturer.

We recommend replacing the pane immediately when there is:

- deformation and/or cracks from impacts
- damage to the sealing
- infiltration of cooling fluid
- damage or destruction to the protection pane (or the scratch-resistant protection film) on the operator or machine side

HEMA safety windows

- Only certified quality panes of polycarbonate are used with an efficient surface coating providing protection against chemicals, abrasion and scratching, film on option
- Polycarbonate panes from renowned manufactures
- Polycarbonate panes can be provided with any of the usual thicknesses. The basic versions range from 5 to 15 mm in thickness.
- PC panes are protected on the machine side by an additional single or multiple layer safety glass pane.
- The design may consist of polycarbonate with abrasion-proof coating and glass depending on customer requirements.
- Splinter proof laminated glass with a low risk of injury and for shorter cleaning and machine downtimes.
- The edges of the panes are completely sealed and resistant to coolants. In addition they can be fitted with stainless steel frame for optimal mounting.
- The panes and their components are tested by the IWF institute in Berlin according to DIN EN 23125, restraint categories A1 to C3, and to safety standards CEN/TC 143/WG3

- The customer receives a 5-year warranty on the encapsulated and sealed safety pane (according to our warranty conditions).
- The integration of modern spin window solutions such as SPINVISTA is possible without any safety risk or additional mounting work.

Design of machine safety windows

»HEMA WINDOW« machine safety windows are suitable for most applications. They can be produced with optional graduation, protection films, steel frames. Also the integration of LED lighting is possible.

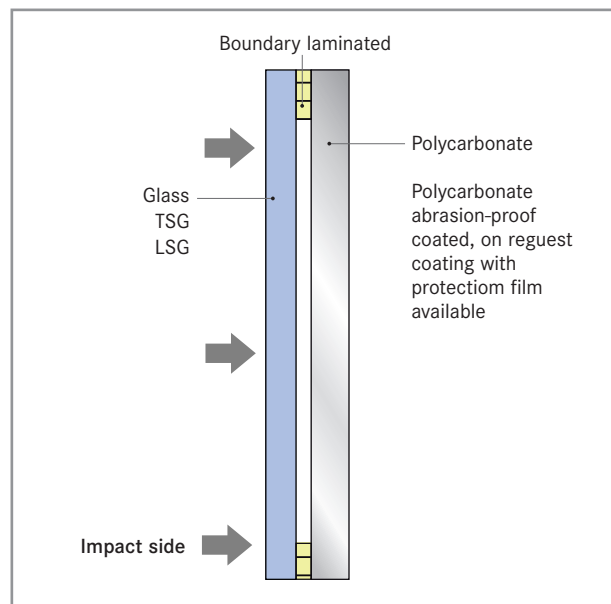

Design of machine safety window

The thickness of polycarbonate and the design of the multi-layer machine safety window is based on the individual requirements and safety classifications.

The HEMA charge number system assures traceability and convenient ordering.



Label inside window

MACHINE SAFETY WINDOW WITH INTEGRATED LIGHTING

03

CONTENT

10

SAFETY WINDOWS

11

SPIN/ISTA
SPIN WINDOWS

Machine safety windows permit safe viewing of machining operations inside the machine tool. Most often there is a need for additional lighting.

Depending on available space and position, conventional lights can become dulled by accumulation of swarf and contamination by coolant.

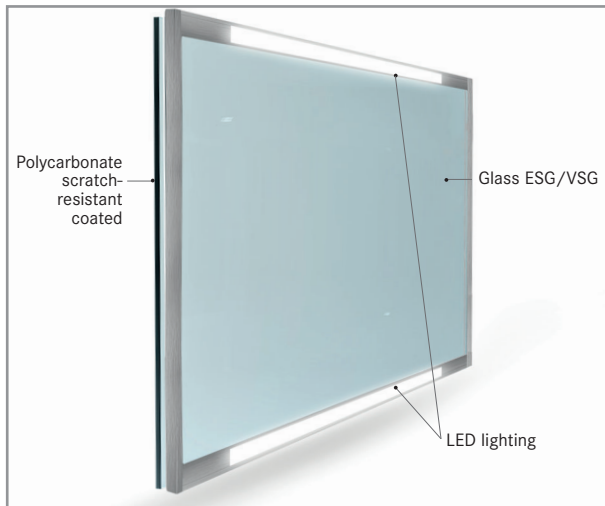

Layout of the safety window with integrated lighting

The optimum solution combines a clear view into the machine with suitable lighting. This solution is available in the form of illuminated HEMA Windows - the integration of LED technology in a machine safety window.

These illuminated safety windows combine the advantages of two established systems in one compact solution.

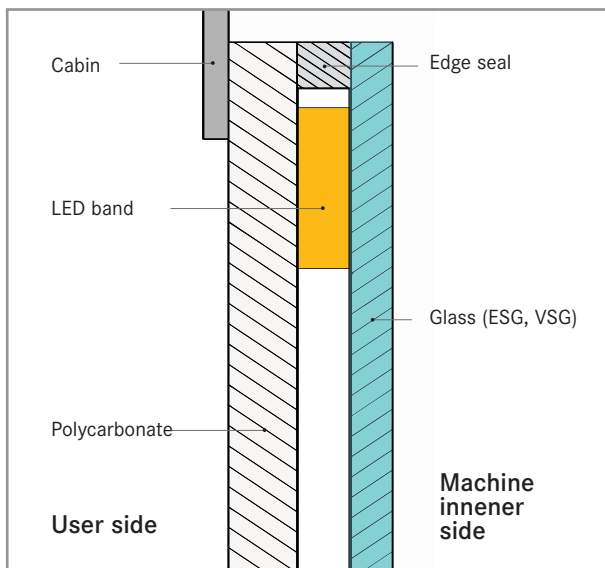

Layout of the safety window with integrated lighting



Machine safety window with LED lighting, length 2 m

The variable position of the LED lighting rails - vertical or horizontal - enables a flexible fitting to requirements of the machine interior. Problems of swarf and coolant contamination of internally mounted lamps will be eliminated. The well proven perimeter seal design ensures the LED's and internal surfaces are protected from ingress of contamination and moisture.

The advantages of HEMA windows with integrated lighting:

- Compact system solution
- Flexible illumination of the machine interior
- Tried and tested LED technology
- Elimination of lamp contamination
- Power supply from the mains or the machine
- Retrofit option on machines

Types

Power supply	24VDC ± 3VDC
Operating voltage	5 W, 10 W, 15 W, 20 W, 30 W, 40 W
Lens	ca. 120°
Light temperature	5700 K
Connection	M12, PUR cable lead 3 m

Due to the complex plug-in system the LED modules can be reused when the machine window is damaged. Our service will be happy to advise you.

SPINVISTA SPIN WINDOWS

SPINVISTA Spin Windows are suitable for all types of CNC milling machines, lathes and machining centres, either retro-fitted or integrated at the factory.



Direct view of the machining process in the machine

The SPINVISTA can be installed both as part of the original OEM equipment and as part of the retrofitting. Work ergonomics and productivity are significantly improved by the generous view of the actual machining process in the machine without impairment of visibility by coolants or swarf.

The light weight, the simple assembly and the optimal maintenance due to the modular design reduce the costs for assembly and maintenance. Complete solutions - machine windows with built-in SPINVISTA spin windows are also available. There is no additional installation effort here. The systems can be pre-configured in such a way that they only have to be installed and connected. All systems meet the respective security requirements.

SPINVISTA Spin windows types EVO and NEO

The SPINVISTA Spin window is available in two versions, which differ in the size of the visible surface:

- **SPINVISTA EVO:** Ideal for replacing already assembled systems in the event of a defect or upgrade, 1: 1 compatible with existing assembly systems from HEMA
- **SPINVISTA NEO:** Larger field of vision with proven functionality

Advantages of SPINVISTA Spin Windows

SPINVISTA is synonymous with active safety precautions: Without SPINVISTA, the operator can be tempted to bypass the safety circuit of the machine to see what is happening in the machine - potential danger with serious consequences! With regard to product liability and safety regulations, take a look at the safety advantages of SPINVISTA - it could pay off.

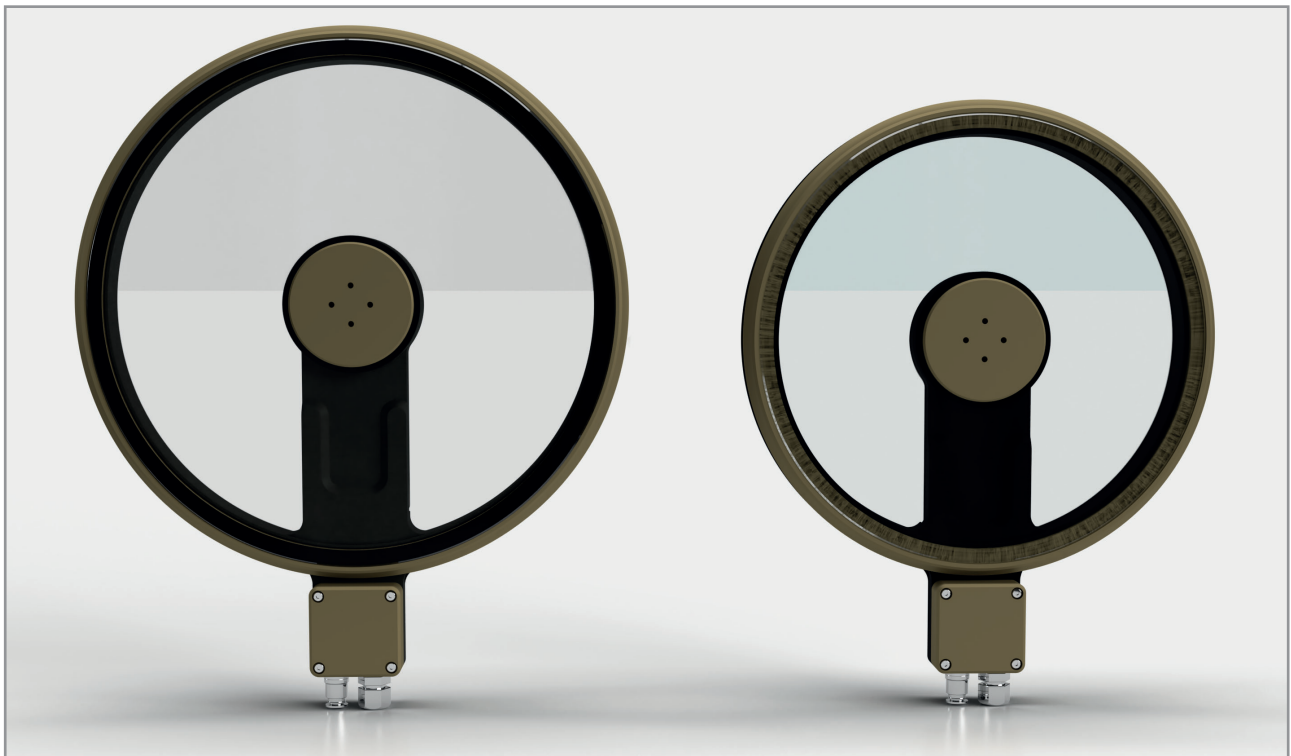

SPINVISTA NEO und SPINVISTA EVO

SPINVISTA SPIN WINDOWS

03

CONTENT

04

SAFETY
WINDOWS

12

SPINVISTA
SPIN WINDOWS

Installation and fixing

No hole has to be drilled in the machine cabin. The unit is either fastened on the bonded mounting plate or bonded directly to the window. The SPINVISTA is either screwed onto the mounting plate or bonded directly onto the safety window. The mounting plate allows fast replacement of the SPINVISTA.

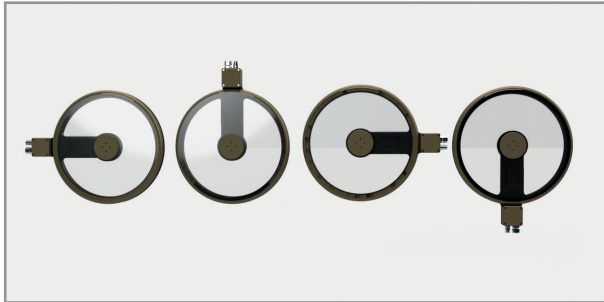

Variable mounting, any position at an angle of 0 ° - 360 ° possible

The SPINVISTA can be mounted on the machine safety disc in any position rotated from 0 ° to 360 ° with a vertical inclination of up to 5 °. The power can be supplied in three positions. It can be installed in the operator's door as well as in a »fixed« window. The flat design with a total height of <32 mm means that it can be easily adapted to a wide variety of door and window designs. If there is enough space, it can also be attached to sliding doors.

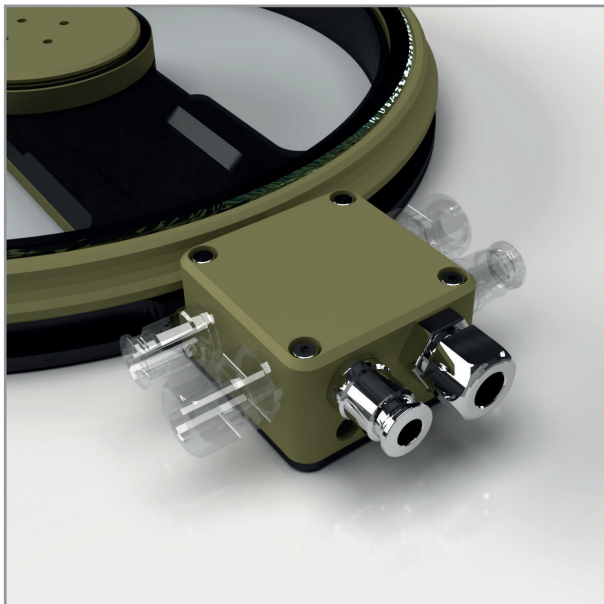

Mounting positions of the power supply

SPINVISTA can be fixed in different ways:

- bonded
- screwed to safety window
- screwed directly to the integrated mounting plate

Bonding

The SPINVISTA is mounted easily with a high-tech adhesive sheet (adhesive based on closed cellular acrylic foam). Simply remove the protective foil on the rear side of the SPINVISTA and bond the SPINVISTA to the desired position on the pane which should be cleaned thoroughly beforehand. The optimal setting time is 72 hours. To speed up installation we offer a special vacuum pump, which reduces the bonding time to 1-2 hours (95% bonding strength). Applying heat to the mounting frame can also help to reduce the bonding time. Afterwards it is very difficult to separate the SPINVISTA from the surface it is bonded to, provided the surface had been cleaned adequately beforehand.

Machine safety windows with integrated mounting plate

The easiest solution is to secure the SPINVISTA to the mounting plate already integrated within the safety window. SPINVISTA only has to be positioned and secured in place with the enclosed screws.

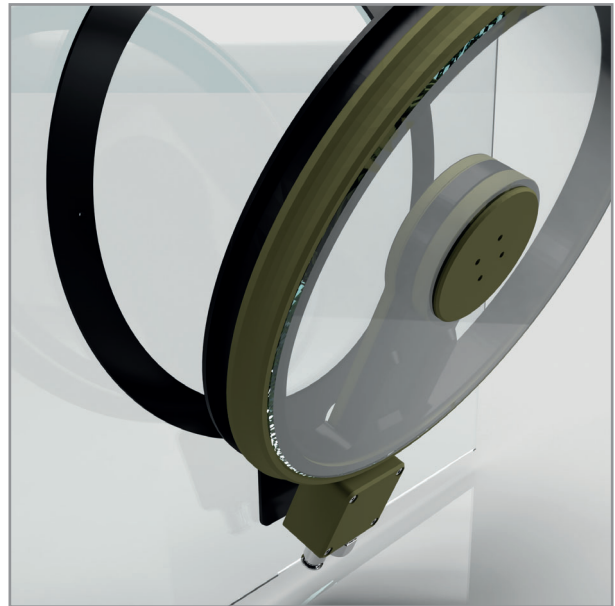

Machine safety window with mounting plate

Screwed to safety window

In this case six holes are drilled through the polycarbonate pane (a process that degrades the pane's resistance). The holes are sealed from the machine's cabin side with an integrated o-ring. On the control side SPINVISTA is fixed in place with a screwed clamping flange

SPINVISTA SPIN WINDOWS

Model	SPINVISTA EVO	SPINVISTA NEO
Application	Milling centers, lathes and grinding machines	Milling centers, lathes and grinding machines
Operating temperatur	10 ° C ... + 50 ° C permissible	10 ° C ... + 50 ° C permissible
Dimensions	Ø 253 mm / 253 x 321 x 31,6 mm	Ø 290 mm / 290 x 358 x 31,6 mm
Inner diameter	Ø 216 mm	Ø 253 mm
Field of view	284 cm ²	430 cm ²
Nominal voltage	24 VDC ± 3V	24 VDC ± 3V
Nominal current	0.5 A (starting current 3.5 A / 24 VDC)	0.5 A (starting current 3.5 A / 24 VDC)
Power consumption	Idle approx. 12 W (24 V, 500 mA)	Idle approx. 12 W (24 V, 500 mA)
Rated speed	2.300 U/min	2.300 U/min
Weight	1.8 kg	2.1 kg
Noise emissionn	<65 dB (A) DIN EN ISO 11200	<65 dB (A) DIN EN ISO 11200
Overpressure / sealing air	min. 20 - 50 mbar (optional)	min. 20 - 50 mbar (optional)
Air consumption	~ 1.1m ³ /h (at 20 mbar)	~ 1,1m ³ /h (at 20 mbar)
Air purity	ISO 8573-1: 2010 [3: 4: 3] required	ISO 8573-1: 2010 [3: 4: 3] required
Mounting	Maximum inclination angle of disc 5° Orientation of connection as required	Maximum inclination angle of disc 5° Orientation of connection as required
Motor	Brushless with blocking and reverse polarity protection	Brushless with blocking and reverse polarity protection

CONTENT 03

SAFETY WINDOWS 04

SPINVISTA SPIN WINDOWS 13

Coolant

SPINVISTA functions best with water based coolants and mineral oils; other oils on request.

Product quality

The basic components are made of high quality aluminum with a hard anodized surface. The electronic components were specially developed for the SPINVISTA and are fully encapsulated and protected against moisture. All parts and components of the SPINVISTA are checked for material quality and service life.

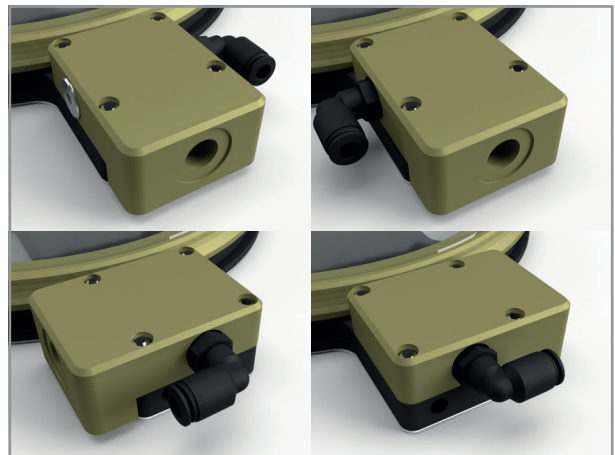

Connection possibilities, example G1/4

SPINVISTA EVO

03

CONTENT

04

SAFETY
WINDOWS

14

SPINVISTA
SPIN WINDOWS

SPINVISTA EVO Spin window

- Spinning disk mounted in the machine side, providing a clear view of the process through its high rotary speed (> 2,300 rpm)
- Viewing area 284 cm²
- Integrated, fully encapsulated control electronics with reverse polarity protection, thermal protection against overheating (150°C)
- Integrated brushless DC motor 24V (± 1V) DC, fully encapsulated
- fulfils CE standards for low tension voltage
- low weight, only about 1.8 kg
- built-in chip protection with specially designed base and disc ring

Connection variants

The SPINVISTA EVO has two connection openings on the base of the device, three connection variants are possible:

Variant A

Connection 1: Screw connection base to FLEX metal wire hose or M12x1.5 cable screw connection

Connection 2: Push-in fitting G1 / 8 for hoses 8 mm or push-in fitting G1 / 8 for hoses 6 mm or G1 / 8 blind plugs



SPINVISTA EVO

Variant B

Connection 1: Connection plug M12

Connection 2: Push-in fitting G1 / 8 for hoses 6 mm

Variant C

G1 / 4 connection box with EO pipe connection for metal pipes with Ø 8, 10 or 12 mm

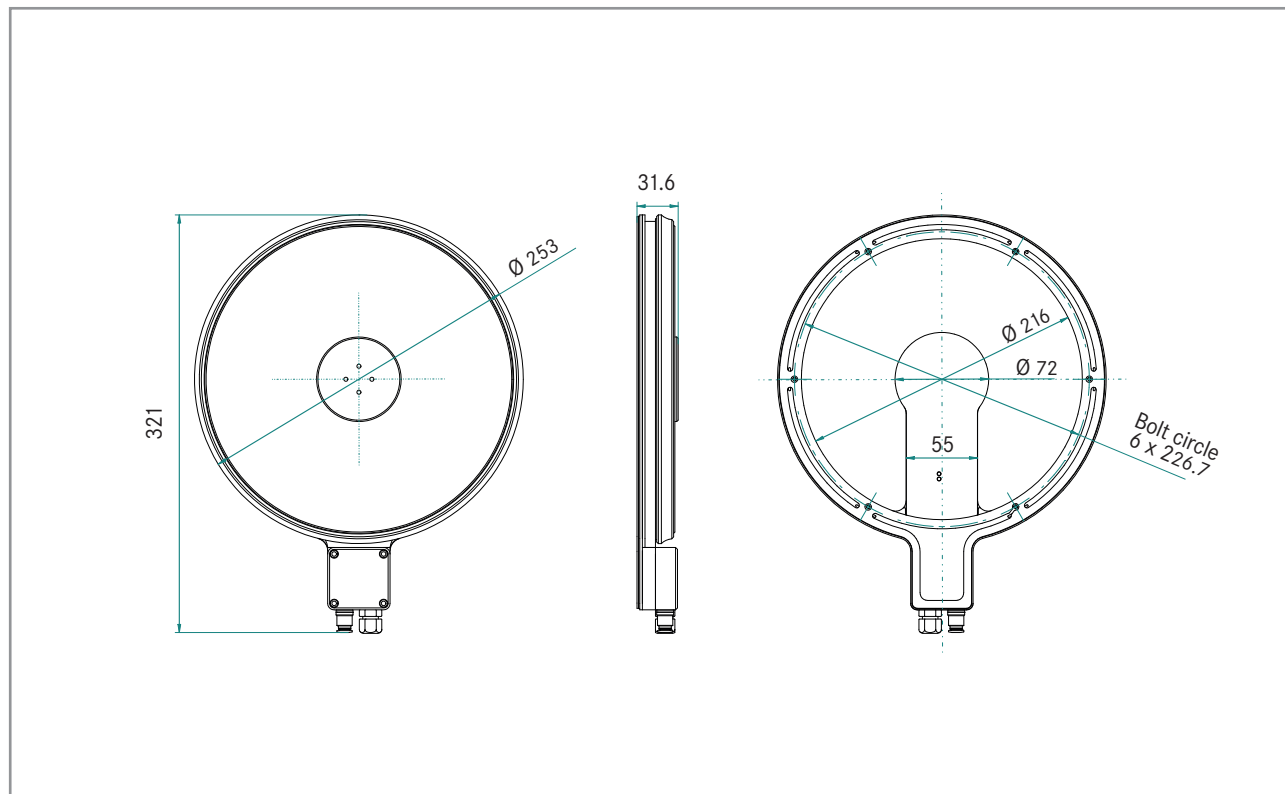

SPINVISTA EVO

SPINVISTA NEO

SPINVISTA NEO Spin window

- Spinning disk mounted in the machine side, providing a clear view of the process through its high rotary speed (> 2,300 rpm)
- Viewing area 410 cm²
- Integrated, fully encapsulated control electronics with reverse polarity protection, thermal protection against overheating (150°C)
- Integrated brushless DC motor 24V (± 1V) DC, fully encapsulated
- fulfils CE standards for low tension voltage
- low weight, only about 2.1 kg
- built-in chip protection with specially designed base and disc ring

Connection variants

The SPINVISTA EVO has two connection openings on the base of the device, three connection variants are possible:

Variant A

- Connection 1: Screw connection base to FLEX metal wire hose or M12x1.5 cable screw connection
- Connection 2: Push-in fitting G1 / 8 for hoses 8 mm or push-in fitting G1 / 8 for hoses 6 mm or G1 / 8 blind plugs



SPINVISTA NEO

Variant B

- Connection 1: Connection plug M12
- Connection 2: Push-in fitting G1 / 8 for hoses 6 mm

Variant C

- G1/4 connection box with EO pipe connection for metal pipes with Ø 8, 10 or 12 mm Ø 8, 10 oder 12 mm

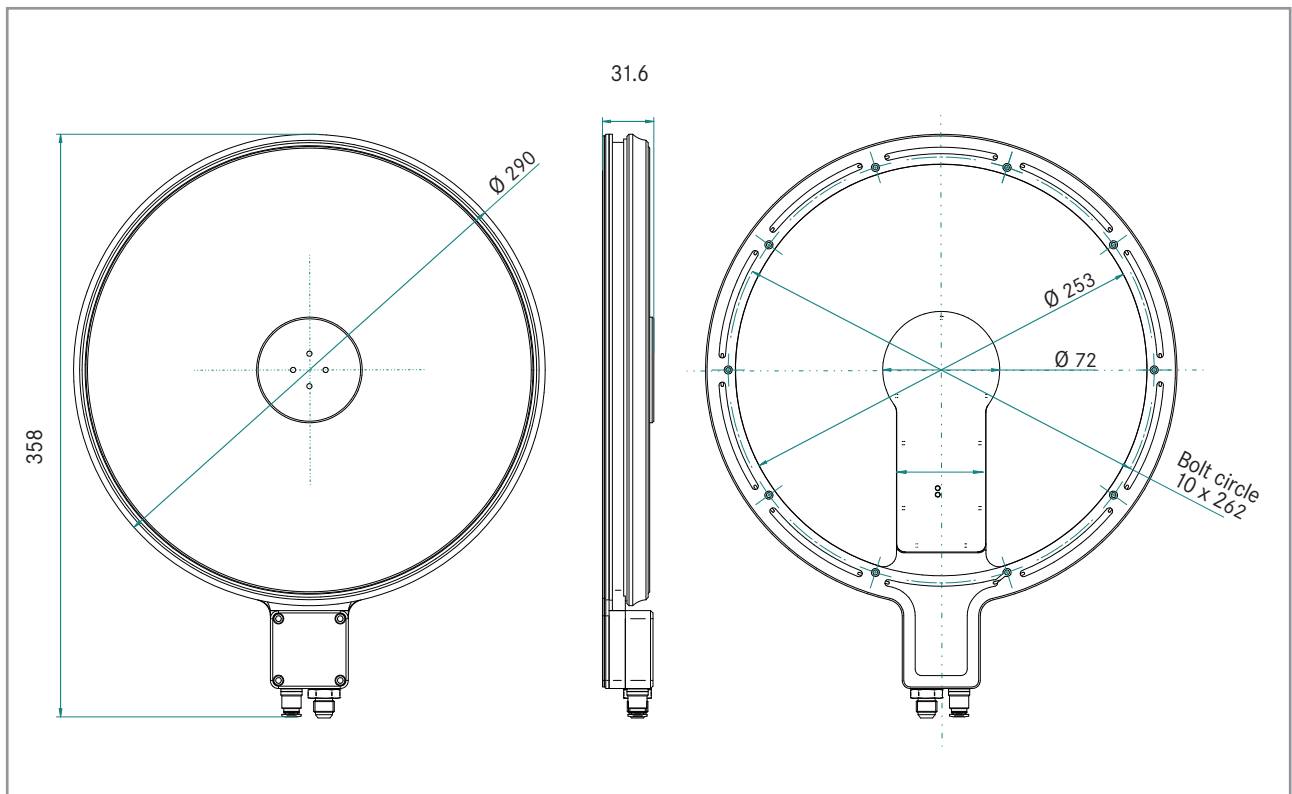

SPINVISTA NEO



Our range of service



Protection systems



Clamping and braking systems



Machine safety windows
Spin windows
LED Lighting systems

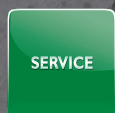

Service, logistics and maintenance

HEMA Maschinen- und
Apparateschutz GmbH
Am Klinggraben 2
63500 Seligenstadt, Germany
Phone: +49 (0) 6182 773-0
Fax: +49 (0) 6182 773-35
E-Mail: info@hema-group.com
Web: www.hema-group.com