



Roll-up Covers

P.E.I. Roll-up Covers are normally equipped with our patented system of multiple springs. This offers countless advantages:

- **Reliability**
- **Extremely high speeds**
- **Resistance to high and low temperatures**
- **1,000,000 movements guaranteed**
- **Compact size**
- **Easy installation**
- **Constant tensioning**
- **Special roll-up covers for machine tools**



STEEL-TEX

A roll-up safety barrier made of **stainless steel**: a band made of **steel material** on a **polyester support**.

- **STEEL-TEX** is cut resistant on impact with incandescent and sharp metal shavings.
- **STEEL-TEX** offers exceptional resistance during dry working or with coolants.
- **STEEL-TEX** is compact, weighs 0.9 kg per sq.m and is 0.8mm thick.
- **STEEL-TEX** can be installed on the entire range of P.E.I. roll-up covers.

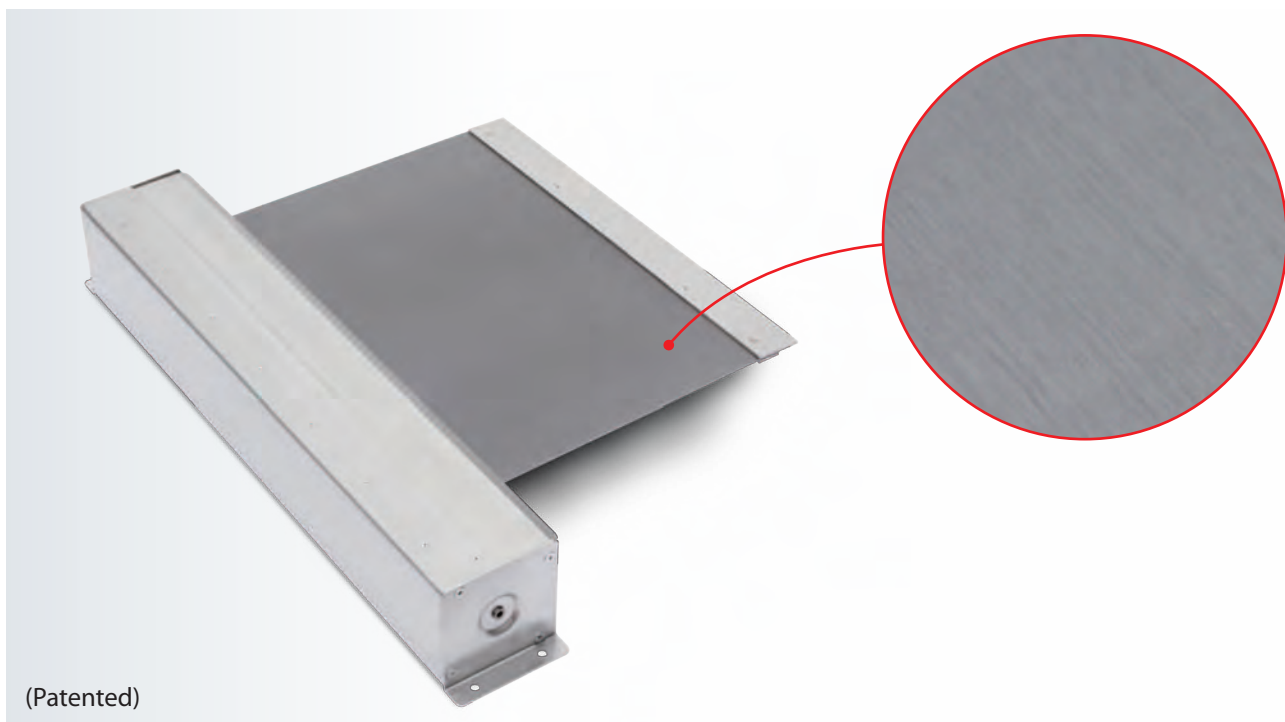

(Patented)



Roll-up Covers without Canister

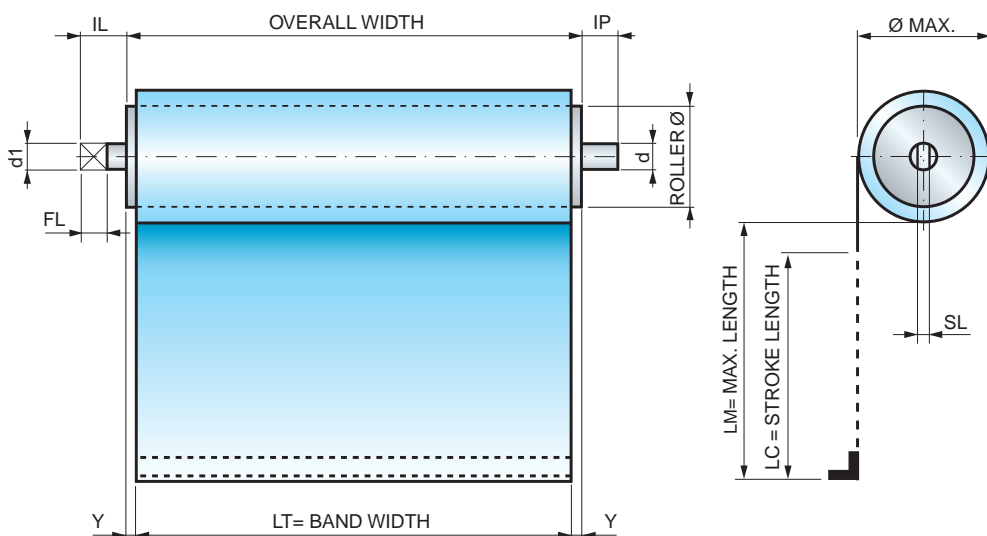

LM		2 · Y =
from	to	
0	400	4
401	600	5
601	800	6
801	1200	8
1201	1600	10
1601	2400	14
2401	3000	18
3001	3850	22
3851	4700	26
4701	5550	32

Shaft sizes

Standard Roll-up Covers

Ø ROLLER	d1	IL	FL	SL	d	IP
30	6	8	8	2,6	7	8
40-50-60-70	10	15	12	4	10	10

For special working conditions, our engineering department can adjust these dimensions. Carefully review the drawing enclosed with the proposal.

SURE-SPRING® Roll-up Covers

Ø ROLLER	d1	IL	FL	SL	d	IP
39-52-71	10	15	12	4	10	10

Formula for calculating the OVERALL WIDTH

$$\text{OVERALL WIDTH} = \text{LT} + 2Y$$

Example:

$$\text{LM} = 1000 \quad \text{LT} = 500 \quad 2Y = 8$$

$$\text{OVERALL WIDTH} = 508$$

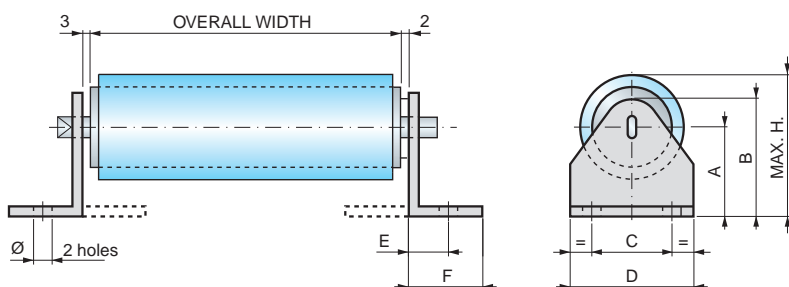

Formula for calculating max. Ø

$$\text{Ø MAX.} = 2 \cdot \sqrt{\frac{L \cdot s \cdot 1,20}{\pi} + r^2}$$

L = MAX. LENGTH TO WIND
s = BAND THICKNESS*
r = ROLLER Ø/2

(* see materials list on pages 56-57)

Measurements for standard supports

Code	A	B	C	D	E	F	Ø	Hmax	Material
033	33	45	26	40	11	18	6,5	59	galvanized Fe 15/10
050	50	62	26	40	11	18	6,5	93	galvanized Fe 15/10
060	60	76	36	50	15	22	6,5	112	galvanized Fe 20/10
080	80	96	42	60	17	26	6,5	151	galvanized Fe 25/10
119	119	136	54	106	37	70	10	225	galvanized Fe 40/10



Roll-up Covers with Canister

Enclosing the roller offers many advantages:

- **Protects roller from accidental impact**
- **Integral wiper keeps band clean**
- **Attractive appearance**
- **Wide variety of fastening systems**
- **Materials: Aluminum, Steel, Stainless Steel**
- **1,000,000 movements guaranteed**

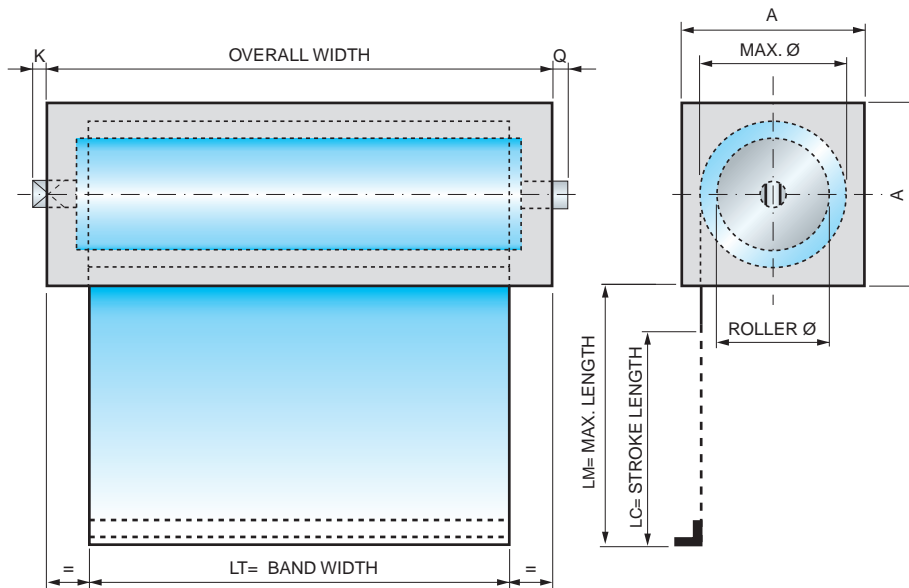

Canisters	
A x A	
40 x 40	
50 x 50	
60 x 60	
70 x 70	
80 x 80	
90 x 90	
100 x 100	
110 x 110	
120 x 120	
130 x 130	
140 x 140	
150 x 150	

Canister material	K	Q	Z*
Aluminum	3	1	25
Steel	10	7	13
Stainless steel	10	7	13

Z*= FIXED COEFFICIENT

Recommended sizes

These tables list the recommended MAX. BAND LENGTH based on the OVERALL WIDTH.

The values shown are guaranteed at a MAX. SPEED of 40 m/min.

For higher speeds and for sizes not indicated in the tables, contact our engineering department

All the Roll-up Covers with or without Canister are manufactured to order.

Ø ROLLER	OVERALL WIDTH	150	250	350	500	750	1000	1250	1500
	MAX. LENGTH.	300	500	650	800	1000	1200	1350	1500
Ø ROLLER 40	OVERALL WIDTH	150	250	350	500	750	1000	1250	1500
	MAX. LENGTH.	400	600	900	1200	1500	1800	2000	2200
Ø ROLLER 50	OVERALL WIDTH	150	250	350	500	750	1000	1250	1500
	MAX. LENGTH.	450	700	1050	1350	1650	2000	2250	2450
Ø ROLLER 60	OVERALL WIDTH	150	250	350	500	750	1000	1250	1500
	MAX. LENGTH.	500	1000	1600	1900	2200	2500	2750	3000
Ø ROLLER 70	OVERALL WIDTH	150	250	350	500	750	1000	1250	1500
	MAX. LENGTH.	550	1100	1750	2050	2350	2600	2900	3150
Ø ROLLER 80	OVERALL WIDTH	150	250	350	500	750	1000	1250	1500
	MAX. LENGTH.	700	1300	2000	2350	2700	3100	3400	3700
Ø ROLLER 90	OVERALL WIDTH	150	250	350	500	750	1000	1250	1500
	MAX. LENGTH.	750	1400	2150	2500	2850	3200	3550	3850
Ø ROLLER 100	OVERALL WIDTH	150	250	350	500	750	1000	1250	1500
	MAX. LENGTH.	800	1500	2300	2650	3000	3300	3700	4000
Ø ROLLER 120	OVERALL WIDTH	150	250	350	500	750	1000	1250	1500
	MAX. LENGTH.	850	1600	2450	2800	3150	3400	3850	4150

Size examples for SURE-SPRING® Roll-up Covers

Ø ROLLER 39	OVERALL WIDTH	250	350	500	750	1000	1250	1500
	MAX. LENGTH.	850	1250	1650	2000	2500	3000	3850
Ø ROLLER 52	OVERALL WIDTH	250	350	500	750	1000	1250	1500
	MAX. LENGTH.	1000	1500	2000	2500	3000	3850	4700
Ø ROLLER 71	OVERALL WIDTH	250	350	500	750	1000	1250	1500
	MAX. LENGTH.	1400	2100	2400	2850	3700	4800	5550

Formula for calculating the Minimum canister size = A

$$A = \text{MAX } \varnothing + 8$$

Formula for calculating the OVERALL WIDTH

With Steel and Stainless Steel canister

$$\text{OVERALL WIDTH} = \text{LT} + \text{Z} + 2\text{Y}^* + \left(\frac{\text{LM}}{100}\right)$$

Example with Steel canister:

$$\text{LT} = 500 \quad 2\text{Y} = 8 \quad \text{LM} = 1000$$

$$\text{LM}/100 = 10 \quad \text{Z} = 13$$

$$\text{OVERALL WIDTH} = 531$$

(* see 2Y table on page 12)



Installing Roll-up Covers

This diagram is valid for all Roll-up Covers, and shows:

- Terminal type
- Terminal position on the band
- Band output direction
- View of shaft/tab

Horizontal and frontal positions

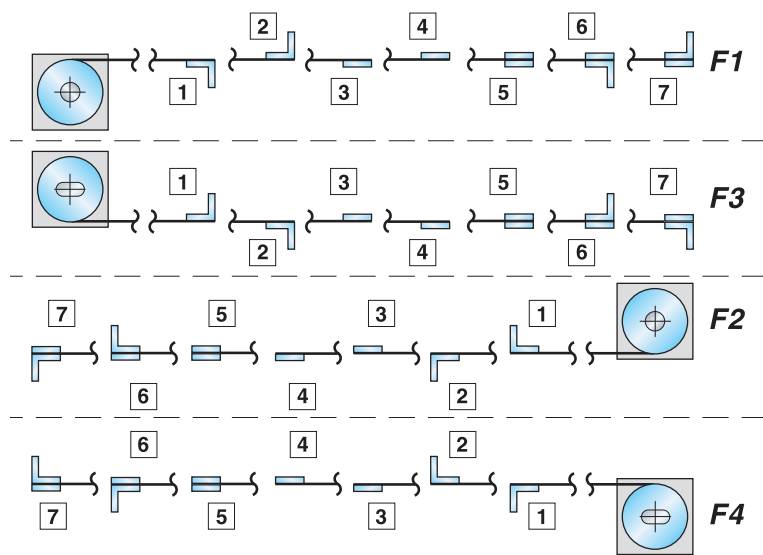

Vertical positions

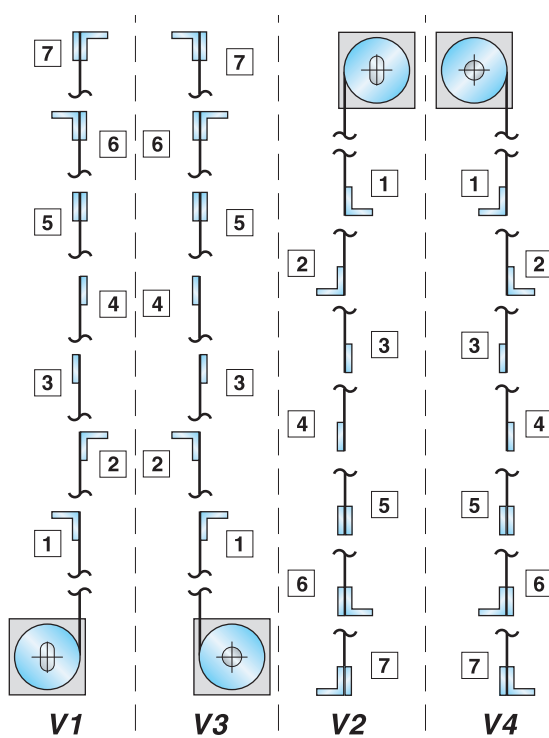

Terminal materials: Aluminum, Steel

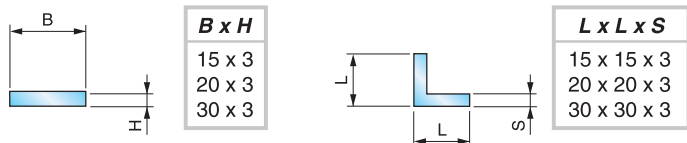

Standard canister mounting systems: To describe the canister attachment system, place one of the drawings below over the selected roll-up cover position, above. Do not rotate either drawing.

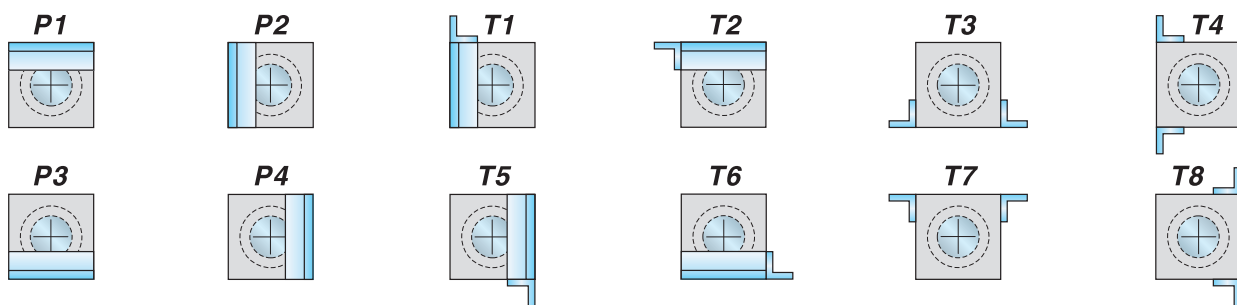

Positions

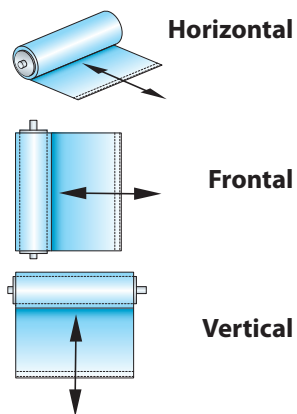

Wiper: This diagram shows the 2 ways to install the wiper to the canister.

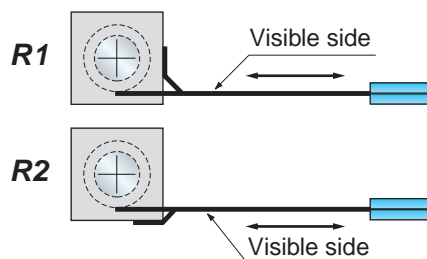

Example assembling code

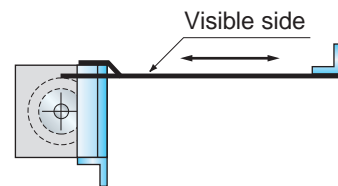

- Working position — F1
- Terminal attachment — 2
- Canister attachment — T5
- Wiper position — R2