



CHUCK

CHUCK SERIES

kitagawa



**ROTARY
CYLINDER**

CYLINDER SERIES



**WORK
GRIPPER**

WORK GRIPPER SERIES



CHUCK



ROTARY CYLINDER



WORK GRIPPER



Head Quarters, Motoyama factory

**CHUCK**

INDEX [Product Description]

Chuck Selection Chart P. 3**Standard Chuck**

Large Thru-Hole High Speed Power Chuck

B-200 series P. 7

Large Thru-Hole High Speed Power Chuck (Direct Mount)

B-200A series P. 8

Large Thru-Hole Power Chuck

B series P. 9

Large Thru-Hole Power Chuck (Direct Mount)

B-A series P. 10

Large Thru-Hole Power Chuck

BB200 series P. 11

Large Thru-Hole Power Chuck (Direct Mount)

BB200A series P. 12

Large Thru-Hole High Speed Power Chuck

BS300 series P. 13

Large Thru-Hole High Speed Power Chuck (Direct Mount)

BS300A series P. 14

Lever Style Power Chuck

BL-200 series P. 15

Lever Style Power Chuck (Direct Mount)

BL200A series P. 16

Counter Balanced Power Chuck

HOH series P. 17

Quick Jaw-Change Chuck

QB300 series P. 18

Quick Jaw Replacement Chuck

QJR series P. 19

2 Jaw Large Thru-Hole High Speed Power Chuck

BT200 series P. 20

2-Jaw Large Thru-Hole Power Chuck

BBT200 series P. 21

2-Jaw Lever Style Power Chuck

BLT200 series P. 22

Closed Centre Power Chuck

N series P. 23

Closed Centre Power Chuck (Direct Mount)

N-A series P. 24

Large Power Chuck for Vertical Lathes

NV series P. 25

Closed Centre Power Chuck (Long Stroke)

NL series P. 26

Closed Centre Power Chuck (Long Stroke, Direct Mount)

NL-A series P. 27

Mega-Long Stroke Chuck

ML series P. 28

2-Jaw Closed Center Power Chuck (NLT-Long Stroke)

NT-NLT series P. 29

2-Jaw Mega-Long Stroke Chuck

MLT series P. 30

1-Jaw Mega-Long Stroke Chuck

MLV series P. 31

4-Jaw Lever Type Power Operated Chuck with Closed Centre

HW series P. 32

3-Jaw Air-Operated Self Contained Chuck

UVE..K series P. 33

3-Jaw Air-Operated Self Contained Chuck

UB series P. 34

3-Jaw Air-Operated Self Contained Chuck (Long Stroke)

UBR series P. 35

3-Jaw Ultra High Precision Air Chuck

KPC series P. 36**Advanced Chuck**

Dual Lock Chuck

DL200 series P. 39

Power Wing Chuck

PW(C) series P. 41

2-Jaw Power Wing Chuck

PWT(C) series P. 43

Open Centre Pull Lock Chuck

PUB series P. 44

Pull Lock Chuck

PU series P. 45

Pull Lock Chuck

PUE series P. 46

Level Lock Chuck

LU series P. 47

Finger Chuck

FG series P. 48

Finger Chuck for Automotive Wheels

FG-V series P. 49

Finger Chuck for Automotive Wheels

FG-L series P. 50

6-Jaw Finger Chuck for Motorcycle Wheels

FG-M series P. 51

Easy Preparation Finger Chuck

FG-Q series P. 52



Cylinder

Compact Style Hydraulic Cylinder with Open Centre SS series	P. 55
Large Thru-Hole High Speed Hydraulic Cylinder with Open Centre S series	P. 56
Large Thru-Hole High Speed Hydraulic Cylinder with Open Centre S-L series	P. 57
High Speed Hydraulic Cylinder with Open Centre F series	P. 58
Coolant Collector Confirmation Device	P. 59
Double Piston Cylinder YW..R series	P. 60
Compact Style Hydraulic Cylinder with Closed Centre M series	P. 61
Hydraulic Cylinder with Closed Centre Y-R series	P. 62
Hydraulic Cylinder with Closed Centre Y-RE series	P. 63
High Speed Air Cylinder with Closed Centre AY-R series	P. 64
Stationary Cylinder YS series	P. 65



Manual Chuck

Scroll Chuck with Integrated Jaw (Straight Recess) SC·JN series	P. 67
Scroll Chuck with 2 piece Jaw (Straight Recess) JN..T series	P. 68
Scroll Chuck with Two Piece Jaw JN..RA series	P. 69
2-Jaw Scroll Chuck JT series	P. 70
4-Jaw Scroll Chuck JS series	P. 71
Independent Chuck (Straight Recess) IC series	P. 72
Independent Chuck (Short Taper) IA series	P. 73



Work Gripper

Work Gripper AS series	P. 75
----------------------------------	-------

Work Gripper (Multi-Plate) AS M.C series	P. 76
2-Jaw Work Gripper AT series	P. 77
2-Jaw Work Gripper (Multi-Plate) AT M.C series	P. 78
Power Wing Work Gripper PWS06	P. 79
Internal Pull Lock Work Gripper PUES06	P. 80
Pull Lock Work Gripper PLS series	P. 81
Jig Module JM200	P. 82
Stationary Scroll Chuck SC-S series	P. 83
Option	P. 84



Jaws and Accessories

Soft Jaws for Power Chuck SB series	P. 87
Hard Jaws for Power Chuck HB series	P. 91
T-nut	P. 92
Hard Jaws for Scroll Chuck HBS series	P. 93
Soft Jaws for Scroll Chuck SBS series	P. 94
Back Plate	P. 95
Chuck Bung	P. 96
Chuck Grease CHUCK GREASE PRO	P. 97
Chuck Grease GREASE NIPPLE	P. 98
Stationary Gripping Meter JFT-S100	P. 99
DATA Compatibilities of Lathes to Short Taper Chucks	P.100
For mounting a directly-mounted type chuck to lathe spindle end	P.102
For order of Scroll parts	P.103



CHUCK

Chuck Selection Chart

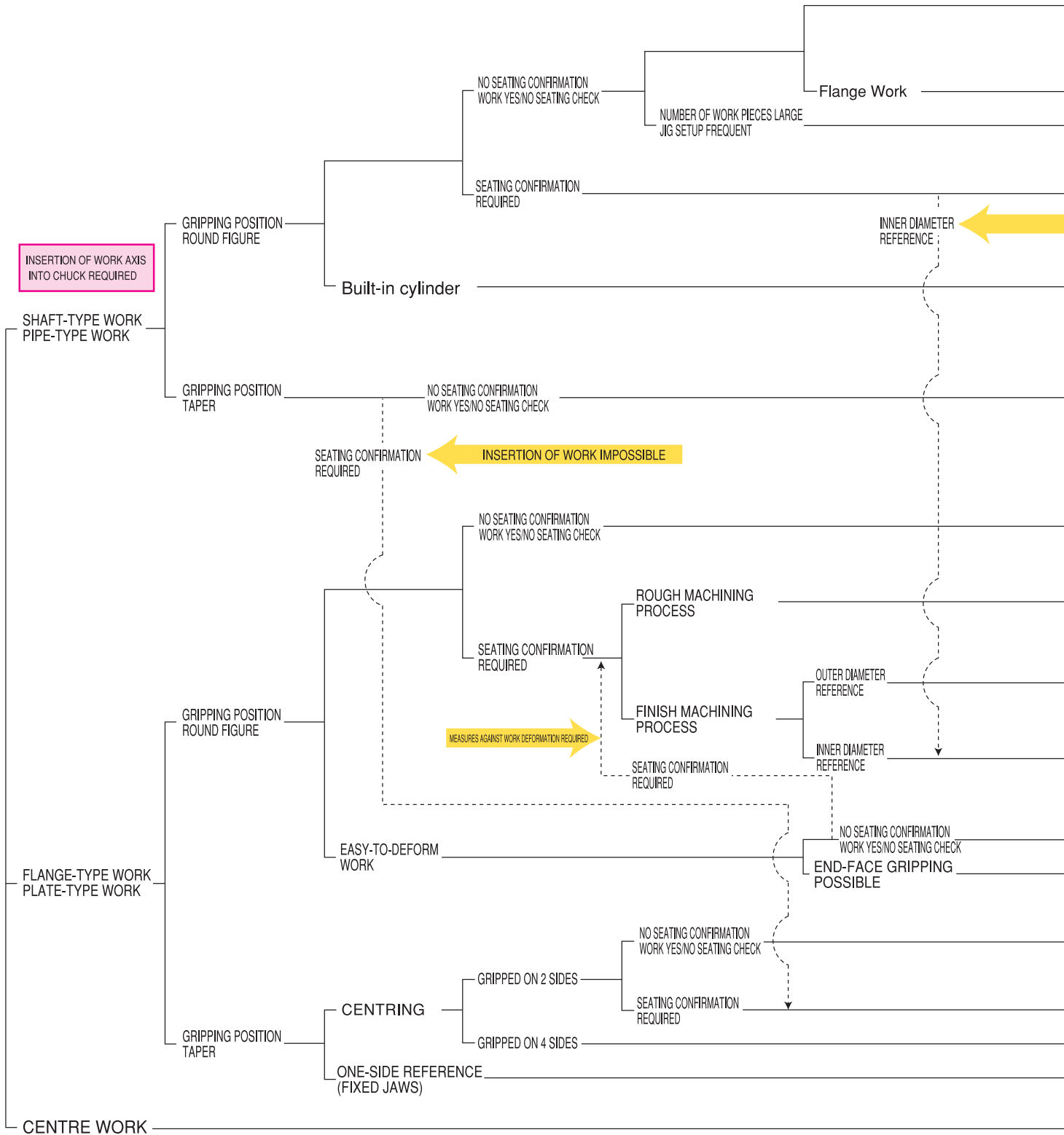

	Catalogue	Corresponding Size (Inches)											
		Page	3	4	5	6	8	10	12	15	18	21	24
INSERTING POSITION WORK DIAMETER LARGE JAW FLOATING REDUCTION HIGH-SPEED ROTATION REQUIRED	BB200	P.11				○	○	○	○				
	BS300	P.13				○	○	○					
	HOH	P.17				○	○	○	○	○			
	B-200/B	P.7~10		○	○	○	○	○	○	○	○	○	○
	BL-200	P.15				○	○	○	○				
	QB300	P.18				○	○	○	○				
STABLE CHUCKING ACCURACY	QJR	P.19					○	○	○				
	PUB200	P.44				○	○	○	○				
	INSERTION OF WORK IMPOSSIBLE												
GRIPPING POSITION DIAMETER SMALL GRIPPING POSITION DIAMETER LARGE MAINLY OIL WELL PIPE	UVE-K	P.33	※Refer to the product page.										
	UB	P.34											
	UBR	P.35											
Flange Work	BT200	P.20		○	○	○	○	○	○				
	BBT200	P.21				○	○	○	○				
	BLT200	P.22				○	○	○	○				
INSERTING POSITION WORK DIAMETER LARGE Flange Work	N	P.23		○	○	○	○	○	○	○	○	○	○
	NV	P.25	※Refer to the product page.										
	NL	P.26		○		○	○	○	○				
FOR VERTICAL WORKING LATHE Flange Work	NL	P.28				○	○						
	ML	P.28				○	○						
SKIP PORTION SMALL SKIP PORTION LARGE	PW	P.41				○	○	○	○	○			
	PU200	P.45	○	○	○	○	○	○	○				
WORK AND JAWS NOT INTERFERE IN UNCLAMP STATE	LU	P.47				○	○	○	○				
	DL200	P.39				○	○	○	○				
8 INCHES OR MORE 6 INCHES OR LESS STABLE CHUCKING ACCURACY	PUE	P.46			○	○	○						
	KPC	P.36	※Refer to the product page.										
FG	FG	P.48			○	○	○	○	○				
	NT/NLT	P.29		○	○	○	○	○	○	○			
Flange Work ※NLT = Long stroke	MLT	P.30				○	○						
	PWT	P.43				○	○	○	○	○			
GRIPPING POSITION ROUND FIGURE GRIPPING POSITION TAPER	HW	P.32					○	○	○	○			
	MLV	P.31				○	○						
GRIPPING POSITION ROUND FIGURE GRIPPING POSITION TAPER	PW-C	P.41				○	○	○	○	○			
	PWT-C	P.43				○	○	○	○	○			

※The contents in this chart are subject to change without notice for further improvement, etc.



CHUCK

kitagawa

Universally recognised and trusted brand offering proven technology

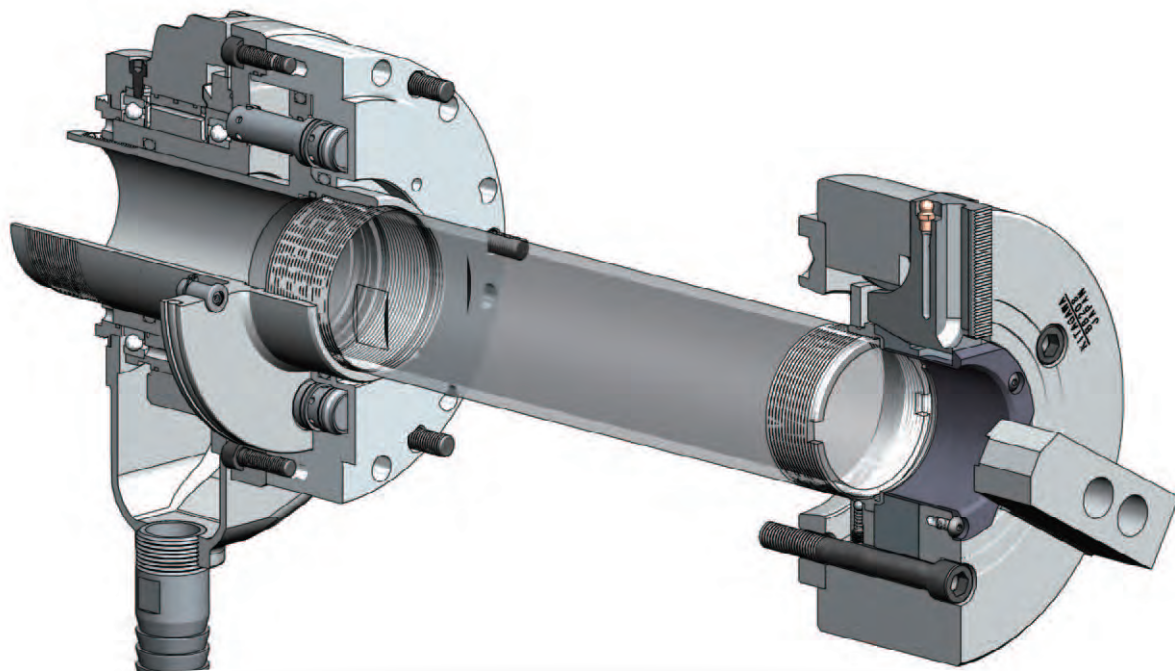

For over half a century, KITAGAWA products have inspired confidence in customers all over the World. The Kitagawa series of chucks is wide-ranging and so technologically advanced that we can offer solutions for all machining conditions, no matter how punishing. Manufacturing systems with exceptional quality controls ensure the production of highly precise and superior products, which guarantee trouble-free operation. Our unique innovations in workholding solutions, supported by highly specialised design teams and a proven history of excellence, shows our capacity to challenge the world of engineering.

**CHUCK****▶ P.7~P.36**

Standard Chuck

Cylinder series exclusive For KITAGAWA chucks

From our standard chucks and cylinders through to our most advanced, this extensive line up combines excellence with performance, and caters for all KITAGAWA chucking.



CHUCK

Large Thru-Hole High Speed Power Chuck B-200 series

World Renowned Standard chuck

* CE correspondence



Dimensional Drawings

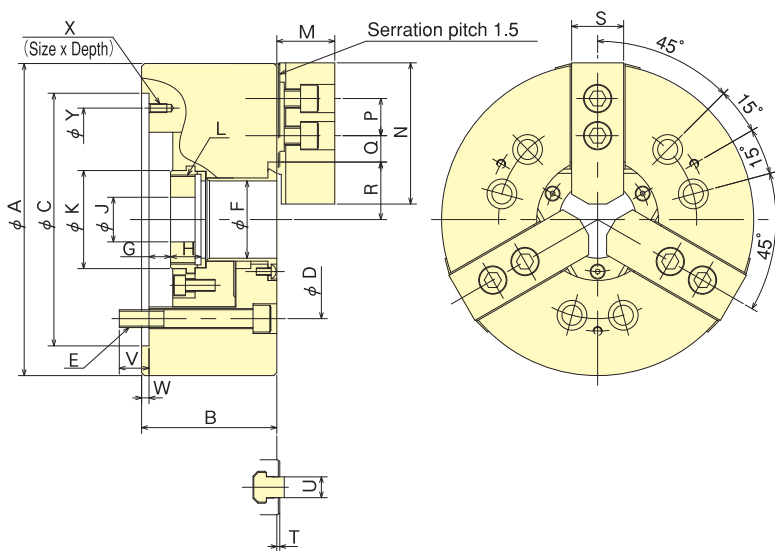

Gripping Example

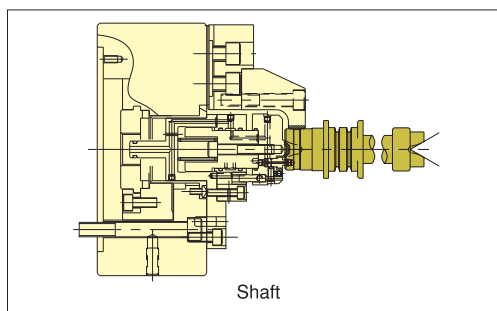

Gripping Characteristic Graphs

*With standard blank soft top jaw.

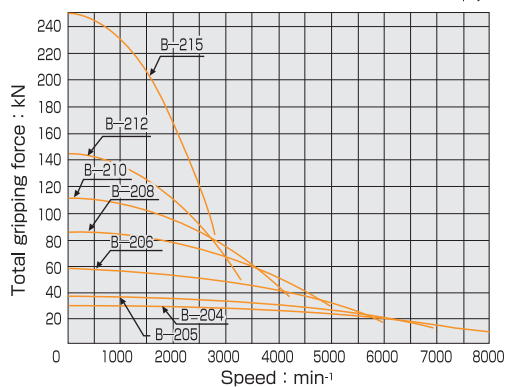

Dimensions *Mounting Bolt P. C. D for B-204 & B-205 : 120° Pitch : 3pcs. *Blank draw nut equipped.

Dimensions Model	A	B	C (H6)	D	E	F	G max.	G min.	H	J	K	L max.	M	N	P	Q max.	Q min.	R max.	R min.	S	T	U	V	W	X (3-)	Y
B-204	110	59	85	70.6	3-M10	26	3.5	- 6.5	17.5	12	38	M32×1.5	24	49.5	14	11.25	6.75	23	20.3	23	2	10	15.5	4	-	-
B-205	135	60	110	82.6	3-M10	33	1	- 9	20	12	45	M40×1.5	26	54	14	19.75	7.75	26.5	23.8	23	2	10	15	4	-	-
B-206	169	81	140	104.8	6-M10	45	11	- 1	19	20	60	M55×2.0	29	66	20	22.75	9.25	32	29.25	26	2	12	16	5	M6×10	116
B-208	210	91	170	133.4	6-M12	52	14.5	- 1.5	20.5	30	66	M60×2.0	39	95	25	29.75	14.75	38.7	35	35	2	14	20	5	M6×12	150
B-210	254	100	220	171.4	6-M16	75	8.5	-10.5	25	45	94	M85×2.0	43	110	30	33.75	14.25	51	46.6	40	2	16	22	5	M8×15	190
B-212	304	110	220	171.4	6-M16	91	8	-15	28	50	108	M100×2.0	51	111	30	45.75	15.75	61.3	56	50	2	21	23	6	M8×15	190
B-215	381	147	300	235.0	6-M20	100	23	0	35	50	120	M110×2.0	61	135	43	54.75	20.25	70	64.7	50	2	25.5	31	6	M10×16	260

Specifications *Max. speed is shown using actual test data.

Specifications Model	Thru-Hole mm	Gripping range mm Max.	Gripping range mm Min.	Jaw Stroke (diameter) mm	Plunger Stroke mm	Max. Draw Bar Pull Force kN (kgf)	Max. Gripping Force kN (kgf)	Max. Speed min ⁻¹	Net Weight with Soft top jaws kg	Moment of Inertia kg·m ²	Matching Cylinder	Max. pressure MPa (kgf/cm ²)	Matching Hard top jaw	Matching Soft top jaw
B-204	26	110	7	5.4	10	14.0 (1428)	28.5 (2906)	8000	4.0	0.007	F0933H	2.80 (28.6)	HB04N1	SBO4N1
B-205	33	135	12	5.4	10	17.5 (1784)	36.0 (3671)	7000	6.7	0.018	F0933H	3.43 (35.0)	HB04N1	SBO5N1
B-206	45	169	16	5.5	12	22.0 (2243)	57.0 (5812)	6000	11.9	0.058	S1246	2.80 (28.6)	HB06B1	SB06L1A
B-208	52	210	13	7.4	16	34.8 (3549)	86.0 (8769)	5000	22.3	0.170	S1552	2.65 (27.0)	HB08A1	SB08B1
B-210	75	254	31	8.8	19	43.0 (4385)	111.0 (11319)	4200	34.5	0.315	S1875	2.70 (27.5)	HB10A1	SB10B1
B-212	91	304	34	10.6	23	55.0 (5608)	144.0 (14686)	3300	55.3	0.738	S2091	2.70 (27.5)	HB12N1	SB12N1
B-215	100	381	50	10.6	23	98.0 (9993)	249.0 (25391)	2800	116.0	2.200	F2511H	3.30 (33.7)	HB15N1	SB15N1



CHUCK

Large Thru-Hole High Speed Power Chuck (Direct Mount) B-200A series

Equipped with Chuck Adaptor to suit Spindle Nose
Universally recognised standard chuck

* CE correspondence



Dimensional Drawings

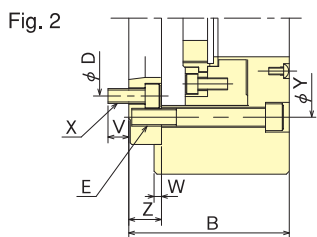
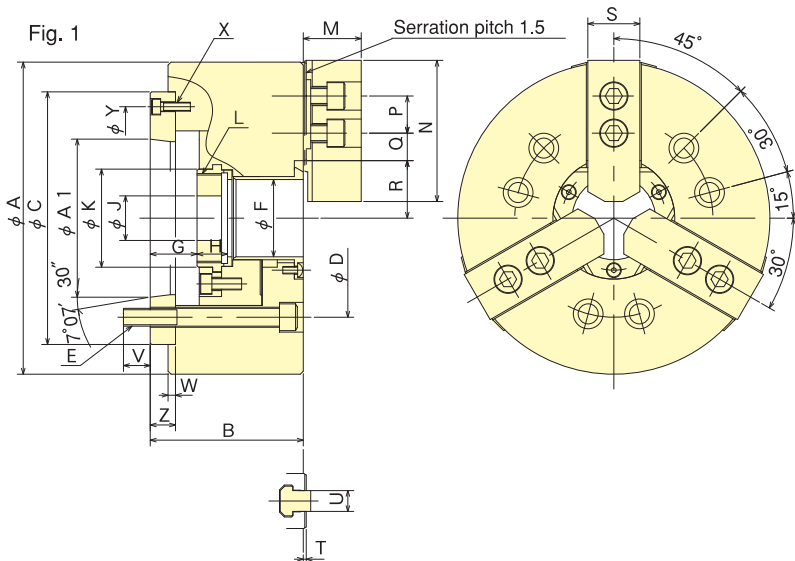

Standard Chuck

Gripping Example

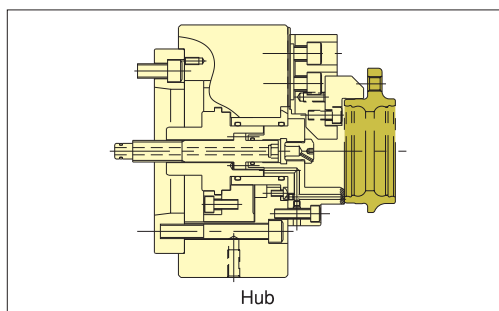

Gripping Characteristic Graphs

※With standard blank soft top jaw.

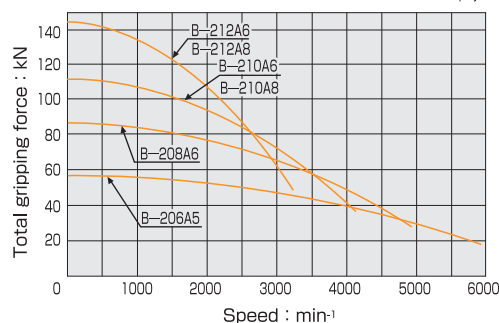

Dimensions

※B-210A6, B-212A6 are referred to in Fig.2. ※Blank draw nut equipped.

Dimensions Model	A	B	C	D	E	F	G max.	G min.	H	J	K	L max.	M	N	P	Q max.	Q min.	R max.	R min.	S	T	U	V	W	X	Y	Z	A1
B-206A5	169	91	140	104.8	6-M10	45	26	14	19	20	60	M55x2.0	29	66	20	22.75	9.25	32	29.25	26	2	12	16	5	3-M 6	116	15	82.563
B-208A6	210	103	170	133.4	6-M12	52	31.5	15.5	20.5	30	66	M60x2.0	39	95	25	29.75	14.75	38.7	35	35	2	14	18	5	3-M 6	150	17	106.375
B-210A6	254	120	220	133.4	6-M16	75	33.5	14.5	25	45	94	M65x2.0	43	110	30	33.75	14.25	51	46.6	40	2	16	18.5	5	6-M12	171.4	25	106.375
B-210A8	254	113	220	171.4	6-M16	75	26.5	7.5	25	45	94	M65x2.0	43	110	30	33.75	14.25	51	46.6	40	2	16	24	5	3-M 8	190	18	139.719
B-212A6	304	129	220	133.4	6-M16	91	33	10	28	50	108	M90x2.0	51	111	30	45.75	15.75	61.3	56	50	2	21	18.5	6	6-M12	171.4	25	106.375
B-212A8	304	122	220	171.4	6-M16	91	26	3	28	50	108	M100x2.0	51	111	30	45.75	15.75	61.3	56	50	2	21	25	6	3-M 8	190	18	139.719

Specifications

※Max. speed is shown using actual test data.

Specifications Model	Thru-Hole	Gripping range mm	Jaw Stroke (diameter) mm	Plunger Stroke mm	Max. Draw Bar Pull Force kN (kgf)	Max. Gripping Force kN (kgf)	Max. Speed min ⁻¹	Net Weight with Soft top jaws kg	Moment of inertia kg·m ²	Matching Cylinder	Max. pressure MPa(kgf/cm ²)	Matching Hard top jaw	Matching Soft top jaw	Spindle nose size
B-206A5	45	169 16	5.5	12	22.0(2243)	57.0 (5812)	6000	13.7	0.063	S1246	2.80 (28.6)	HB06B1	SB06L1A	A2-5
B-208A6	52	210 13	7.4	16	34.8(3549)	86.0 (8769)	5000	23.6	0.178	S1552	2.65 (27.0)	HB08A1	SB08B1	A2-6
B-210A6	75	254 31	8.8	19	43.0(4385)	111.0 (11319)	4200	41.5	0.325	S1875	2.70 (27.5)	HB10A1	SB10B1	A2-6
B-210A8	75	254 31	8.8	19	43.0(4385)	111.0 (11319)	4200	40.0	0.323	S1875	2.70 (27.5)	HB10A1	SB10B1	A2-8
B-212A6	91	304 34	10.6	23	55.0(5608)	144.0 (14684)	3300	67.0	0.780	S2091	2.70 (27.5)	HB12N1	SB12N1	A2-6
B-212A8	91	304 34	10.6	23	55.0(5608)	144.0 (14684)	3300	64.0	0.765	S2091	2.70 (27.5)	HB12N1	SB12N1	A2-8



CHUCK

Large Thru-Hole Power Chuck

B series

Stable Machining for Large Work Pieces
Universally recognised standard chuck



● **Through-hole**

15inch ϕ 117.5 · 18inch ϕ 117.5
 21inch ϕ 140.0 · 24inch ϕ 165.0

* CE correspondence

■ **Dimensional Drawings**

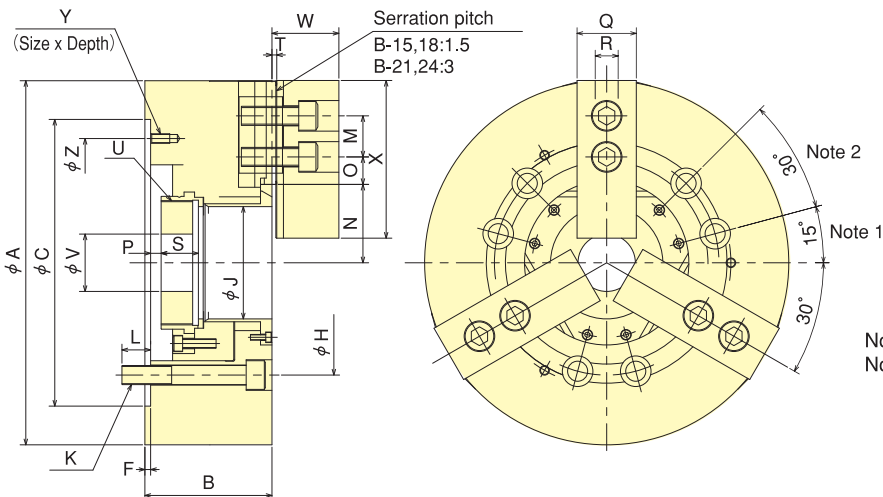

Note 1) B-21, 24 : 0°
 Note 2) B-21, 24 : 60°

Gripping Characteristic Graphs

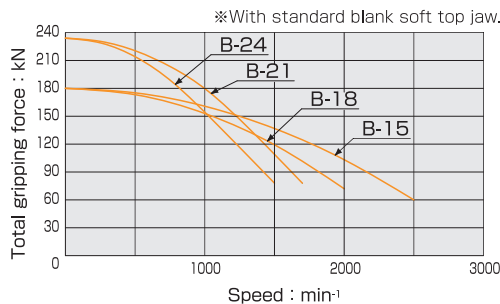

■ **Dimensions** ※Blank draw nut equipped.

Dimensions Model	A	B	C (H6)	F	H	J	K	L	M	N max.	N min.	O max.	O min.	P max.	P min.	Q	R	S	T	U max.	V	W	X	Y	Z
	B-15	381	133	300	6	235.0	117.5	6-M20	30	43	82	76.7	43.75	18.25	11	-12	62	22	39	5	M130x2.0	60	70	165	M10x20
B-18	450	133	380	6	235.0	117.5	6-M20	30	43	82	76.7	78.25	18.25	11	-12	62	22	39	5	M130x2.0	60	70	165	M10x20	320
B-21	530	140	380	6	330.2	140	6-M22	31	60	98.5	93.2	87.5	21.5	11	-12	65	25	39	5	M155x3.0	80	73	180	M12x30	330.2
B-24	610	149	380	6	330.2	165	6-M22	32	60	108	102.7	117.5	21.5	20	-3	65	25	40.5	5	M175x3.0	80	73	180	M12x25	330.2

■ **Specifications**

Specifications Model	Thru-Hole mm	Gripping range mm		Jaw Stroke (diameter) mm	Plunger Stroke mm	Max. Draw Bar Pull Force kN (kgf)	Max. Gripping Force kN (kgf)	Max. Speed min ⁻¹	Net Weight with Soft top jaws kg	Moment of Inertia kg·m ²	Matching Cylinder	Max. pressure MPa(kgf/cm ²)	Matching Hard top jaw	Matching Soft top jaw
		Max.	Min.											
B-15	117.5	381	30	10.6	23	71.0 (7240)	180.0 (18355)	2500	120.0	2.273	F2511H	2.30 (23.5)	HB15A1	SB15C1
B-18	117.5	450	30	10.6	23	71.0 (7240)	180.0 (18355)	2000	164.0	4.451	F2511H	2.30 (23.5)	HB15A1	SB15C1
B-21	140	530	87	10.6	23	90.0 (9177)	234.0 (23861)	1700	235.0	8.950	F2511H	3.00 (30.6)	HB18B2	SB18A2
B-24	165	610	109	10.6	23	90.0 (9177)	234.0 (23861)	1400	293.0	16.600	F2511H	3.00 (30.6)	HB18B2	SB18A2



CHUCK

Large Thru-Hole Power Chuck (Direct Mount)

B-A series

Equipped with Chuck Adaptor to suit Spindle Nose
Universally recognised standard chuck

* CE correspondence

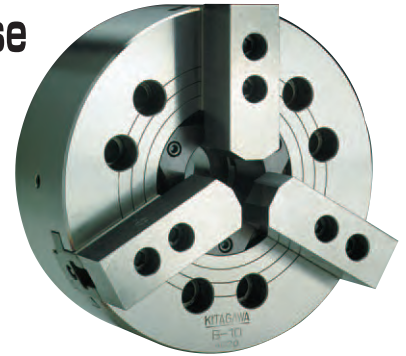

Standard Chuck

Dimensional Drawings

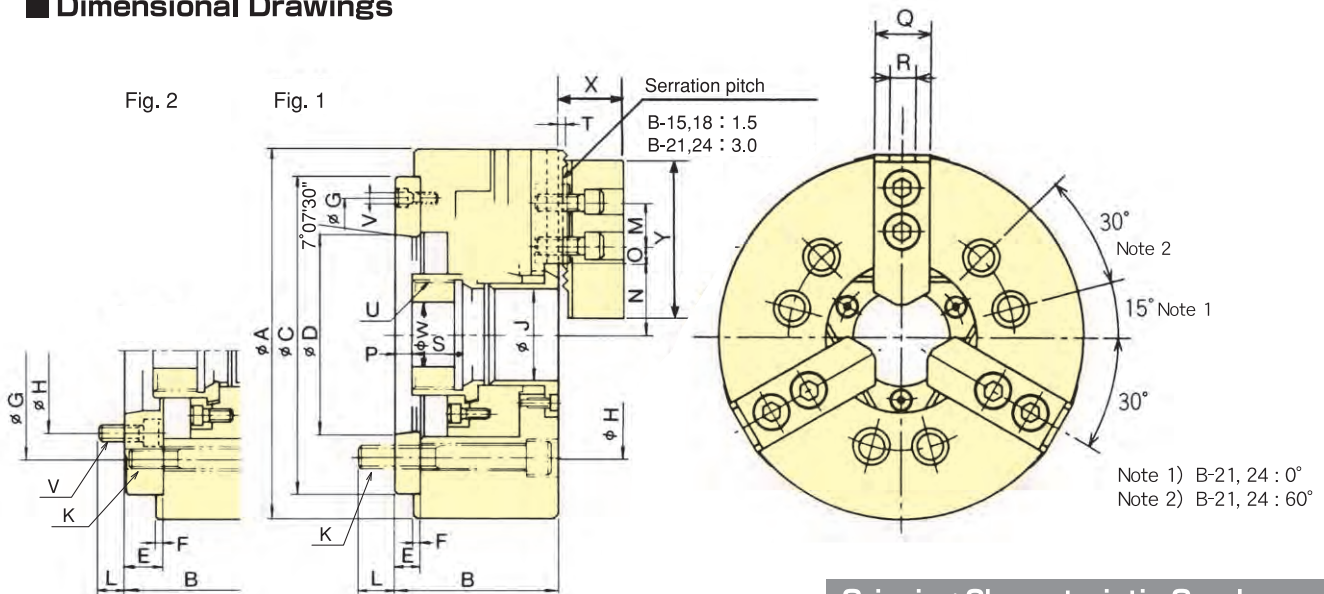

Gripping Characteristic Graphs

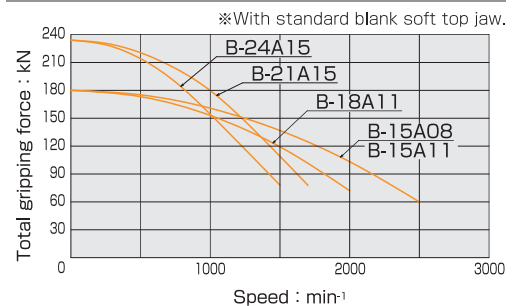

Dimensions

*B-15A08 is referred to in Fig.2. *Blank draw nut equipped.

Model	A	B	C	D	E	F	G	H	J	K	L	M	N max.	N min.	O max.	O min.	P max.	P min.	Q	R	S	T	U max.	V	W	X	Y
B-15A08	381	160	300	139.719	33	6	235	171.4	117.5	6-M20	24	43	82	76.7	43.75	18.25	44	21	62	22	39	5	M130x2.0	6-M16	60	70	165
B-15A11	381	149	300	196.869	22	6	260	235.0	117.5	6-M20	28	43	82	76.7	43.75	18.25	33	10	62	22	39	5	M130x2.0	3-M10	60	70	165
B-18A11	450	149	380	196.869	22	6	320	235.0	117.5	6-M20	28	43	82	76.7	78.25	18.25	33	10	62	22	39	5	M130x2.0	3-M10	60	70	165
B-21A15	530	161	380	285.775	27	6	330.2	330.2	140	6-M22	34	60	98.5	93.2	87.5	21.5	38	15	65	25	39	5	M155x3.0	3-M12	80	73	180
B-24A15	610	170	380	285.775	27	6	330.2	330.2	165	6-M22	35	60	108	102.7	117.5	21.5	47	24	65	25	40.5	5	M175x3.0	3-M12	80	73	180

Specifications

Model	Thru-Hole mm	Gripping range mm Max. Min.	Jaw Stroke (diameter) mm	Plunger Stroke mm	Max. Draw Bar Pull Force kN (kgf)	Max. Gripping Force kN (kgf)	Max. Speed min ⁻¹	Net Weight with Soft top jaws kg	Moment of inertia kg·m ²	Matching Cylinder	Max. pressure MPa (kgf/cm ²)	Matching Hard top jaw	Matching Soft top jaw	Spindle nose size
B-15A08	117.5	381 30	10.6	23	71.0 (7240)	180.0 (18355)	2500	134.0	2.470	F2511H	2.30 (23.5)	HB15A1	SB15C1	A2-8
B-15A11	117.5	381 30	10.6	23	71.0 (7240)	180.0 (18355)	2500	127.0	2.385	F2511H	2.30 (23.5)	HB15A1	SB15C1	A2-11
B-18A11	117.5	450 30	10.6	23	71.0 (7240)	180.0 (18355)	2000	178.0	4.775	F2511H	2.30 (23.5)	HB15A1	SB15C1	A2-11
B-21A15	140	530 87	10.6	23	90.0 (9177)	234.0 (23861)	1700	246.0	9.250	F2511H	3.00 (30.6)	HB18B2	SB18A2	A2-15
B-24A15	165	610 109	10.6	23	90.0 (9177)	234.0 (23861)	1400	304.0	16.850	F2511H	3.00 (30.6)	HB18B2	SB18A2	A2-15



CHUCK

Large Thru-Hole Power Chuck BB200 series

Stable machining even for large diameter bar material
Universally recognised standard chuck



- Standard Soft Jaw can be used for B-200 series as well
- Large through-hole
6 inch ϕ 53 · 8 inch ϕ 66
10inch ϕ 81 · 12inch ϕ 106
- * CE correspondence

Dimensional Drawings

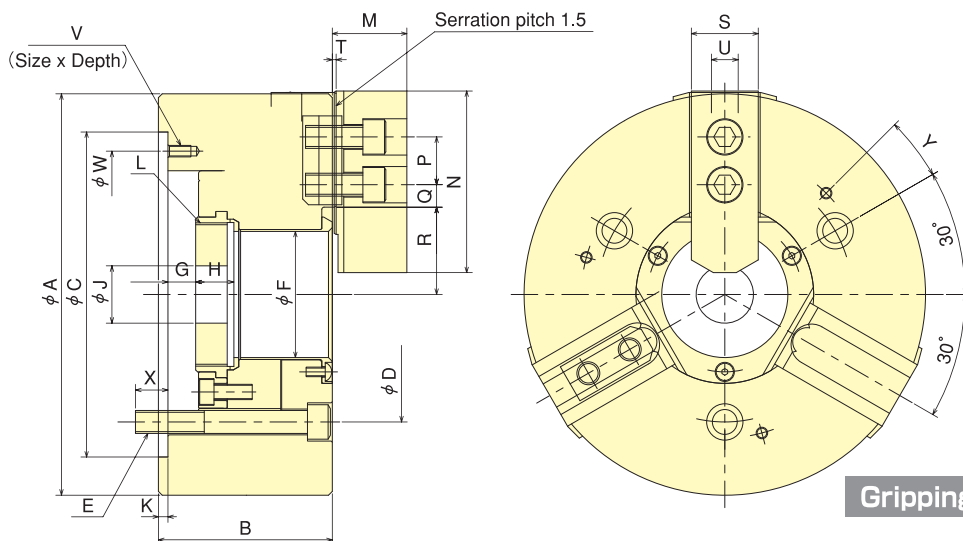

Gripping Characteristic Graphs

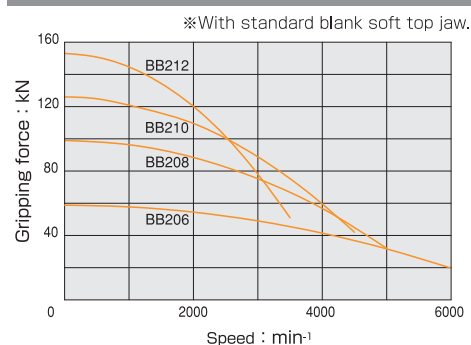

Dimensions

※Blank draw nut equipped.

Dimensions Model	A	B	C (H6)	D	E	F	G max.	G min.	H	J	K	L max.	M	N	P	Q max.	Q min.	R max.	R min.	S	T	U	V	W	X	Y
BB206	170	81	140	104.8	3-M10	53	11	-1	17.5	20	5	M60x2.0	33.2	72	20	21.25	10.75	36	33.25	31	2	12	M6x10	116	16	-30°
BB208	210	91	170	133.4	3-M12	66	14.5	-1.5	20	30	5	M75x2.0	39	95	25	23.75	11.75	45.7	42	35	2	14	M6x12	150	17	15°
BB210	254	100	220	171.4	3-M16	81	8.5	-10.5	25	45	5	M90x2.0	43.2	110	30	32.25	14.25	54	49.6	40	2	16	M8x15	190	22	-15°
BB212	315	108	300	235	3-M20	106	8	-15	28	50	6	M115x2.0	51.7	111	30	45.75	15.75	67.8	62.5	50	2.5	21	M10x16	260	29	-15°

Specifications

Specifications Model	Gripping range mm Max. Min.	Jaw Stroke (diameter) mm	Plunger Stroke mm	Max. input kN (kgf)	Max. static gripping Force kN (kgf)	Max. Speed min ⁻¹	Mass (with standard jaws) kg	Moment of inertia kg·m ²	Compatible cylinder	Max. setting hydraulic pressure MPa (kgf/cm ²)	Standard soft jaw
BB206	170 19	5.5	12	20.0 (2039)	58.5 (5965)	6000	11.7	0.050	SS1453K	1.88 (19.2)	SB06B1
BB208	210 23	7.4	16	32.0 (3263)	99.0 (10095)	5000	23.0	0.143	SS1666K	2.34 (23.9)	SB08B1
BB210	254 41	8.8	19	48.8 (4976)	126.0 (12848)	4500	31.8	0.312	SS1881K	3.09 (31.5)	SB10B1
BB212	315 47	10.6	23	59.0 (6016)	153.0 (15601)	3500	52.0	0.736	SS2110K	2.94 (30.0)	SB12N1



CHUCK

Large Thru-Hole Power Chuck (Direct Mount) BB200A series

Chuck Adaptor is equipped to suit Spindle Nose
Universally recognised standard chuck

* CE correspondence



Standard Chuck

Dimensional Drawings

Fig.2

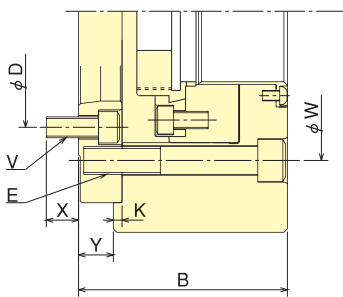
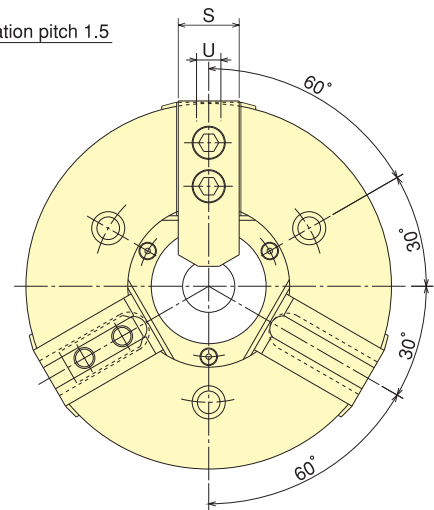
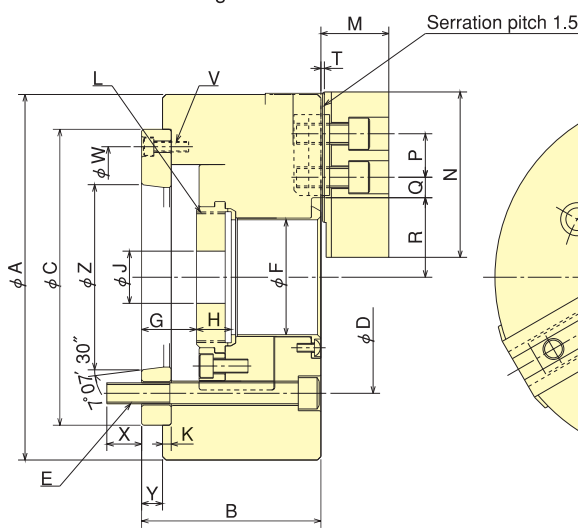
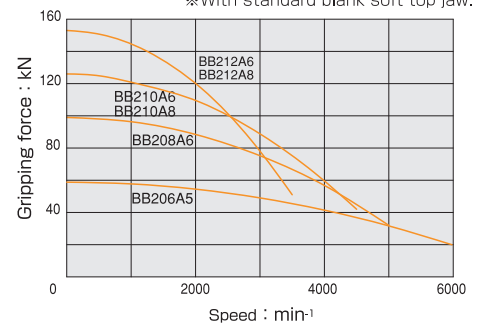

Fig.1



Gripping Characteristic Graphs

*With standard blank soft top jaw.



Dimensions *BB210A6, BB212A6, and BB212A8 are based on Fig. 2. *Blank draw nut equipped.

Dimensions Model	A	B	C	D	E	F	G max.	G min.	H	J	K	L max.	M	N	P	Q max.	Q min.	R max.	R min.	S	T	U	V	W	X	Y	Z
	BB206A5	170	91	140	104.8	3-M10	53	26	14	17.5	20	5	M60x2.0	33.2	72	20	21.25	10.75	36	33.25	31	2	12	3-M6	116	16	10
BB208A6	210	103	170	133.4	3-M12	66	31.5	15.5	20	30	5	M75x2.0	39	95	25	23.75	11.75	45.7	42	35	2	14	3-M6	150	20	12	106.375
BB210A6	254	120	220	133.4	3-M16	81	33.5	14.5	25	45	5	M90x2.0	43.2	110	30	32.25	14.25	54	49.6	40	2	16	6-M12	171.4	18.5	20	106.375
BB210A8	254	113	220	171.4	3-M16	81	26.5	7.5	25	45	5	M90x2.0	43.2	110	30	32.25	14.25	54	49.6	40	2	16	3-M8	190	24	13	139.719
BB212A6	315	148	300	133.4	3-M20	106	54	31	28	50	6	M115x2.0	51.7	111	30	45.75	15.75	67.8	62.5	50	2.5	21	9-M12	235	24	40	106.375
BB212A8	315	135	300	171.4	3-M20	106	41	18	28	50	6	M115x2.0	51.7	111	30	45.75	15.75	67.8	62.5	50	2.5	21	6-M16	235	24	27	139.719

Specifications

Specifications Model	Gripping range mm		Jaw Stroke (diameter) mm	Plunger Stroke mm	Max. input kN (kgf)	Max. static gripping Force kN (kgf)	Max. Speed min⁻¹	Mass (with standard jaws) kg	Moment of inertia kg·m²	Compatible cylinder	Max. setting hydraulic pressure MPa (kgf/cm²)	Standard soft jaw
	Max.	Min.										
BB206A5	170	19	5.5	12	20.0 (2039)	58.5 (5965)	6000	12.7	0.051	SS1453K	1.88 (19.2)	SB06B1
BB208A6	210	23	7.4	16	32.0 (3263)	99.0 (10095)	5000	25.0	0.143	SS1666K	2.34 (23.9)	SB08B1
BB210A6	254	41	8.8	19	48.8 (4976)	126.0 (12848)	4500	37.6	0.355	SS1881K	3.09 (31.5)	SB10B1
BB210A8	254	41	8.8	19	48.8 (4976)	126.0 (12848)	4500	34.7	0.317	SS1881K	3.09 (31.5)	SB10B1
BB212A6	315	47	10.6	23	59.0 (6016)	153.0 (15601)	3500	68.5	0.945	SS2110K	2.94 (30.0)	SB12N1
BB212A8	315	47	10.6	23	59.0 (6016)	153.0 (15601)	3500	66.4	0.933	SS2110K	2.94 (30.0)	SB12N1



CHUCK

Large Thru-Hole High Speed Power Chuck BS300 series

Reduced Jaw Lift The next generation chucking standard



- Compatible with B-200 series
- 30% drop in bending moment of Master-Jaw

30% Jaw lift reduction by side wedge design.
(Conventional Company Products : B-200 SERIES)

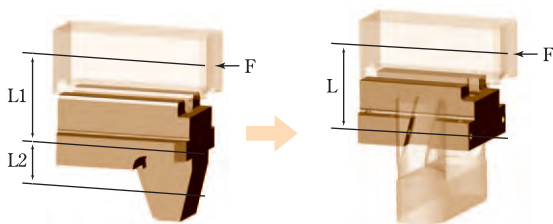

$$F (L1 + L2) \gg F \times L \doteq 1.3 : 1$$

Existing Master-Jaw Side Wedge designed Master-Jaw

Dimensional Drawings

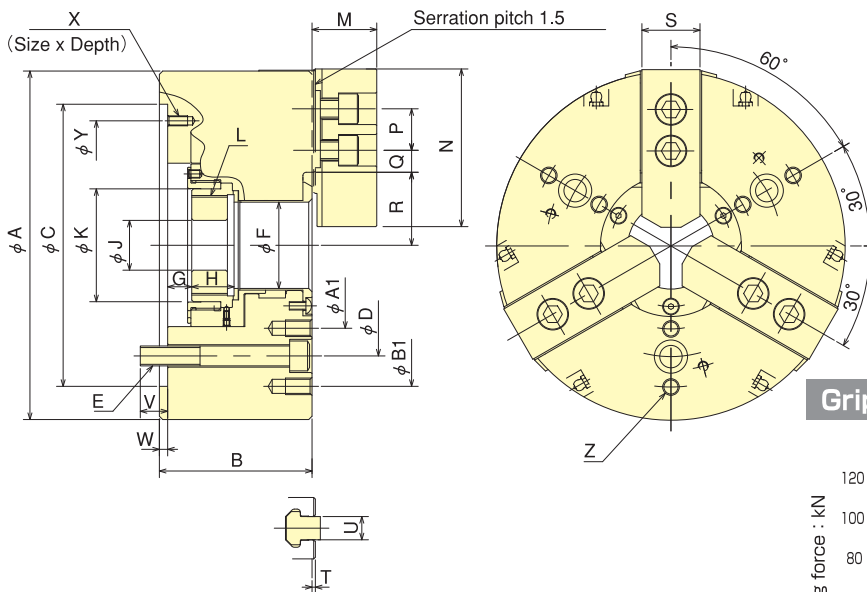

Gripping Characteristic Graphs

※With standard blank soft top jaw.

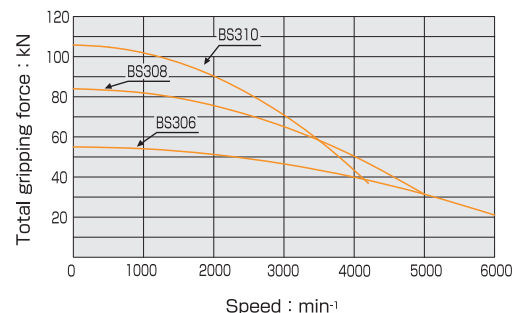

Dimensions ※Blank draw nut equipped.

Dimensions Model	A	B	C (H6)	D	E	F	G max.	G min.	H	J	K	L max.	M	N	P	Q max.	Q min.	Q max.	R min.	S	T	U	V	W	X	Y	Z	A1	B1
BS306	169	85	140	104.8	3M10	45	11	-1	20	20	61	M55x2.0	29	66	20	21.25	9.25	35	32.25	26	2	12	16.5	5	M6x10	116	3x2-M8	77.5	140
BS308	210	92	170	133.4	3M12	52	14.5	0.5	25.5	30	68	M60x2.0	39	95	25	23.75	11.75	44	40.25	35	2	14	16.5	5	M6x12	150	3x2-M10	100	170
BS310	254	103	220	171.4	3M16	75	8.5	-8.5	32.5	45	94	M85x2.0	43	110	30	30.75	11.25	55	50.45	40	2	16	23.2	5	M8x15	190	3x2-M10	128	216

Specifications

Specifications Model	Thru-Hole mm	Gripping range mm Max.	Gripping range mm Min.	Jaw Stroke (diameter) mm	Plunger Stroke mm	Max. Draw Bar Pull Force kN (kef)	Max. Gripping Force kN (kef)	Max. Speed min⁻¹	Net Weight with Soft top jaws kg	Moment of inertia kg·m²	Matching Cylinder	Max. pressure MPa (kef/cm²)	Matching Hard top jaw	Matching Soft top jaw
BS306	45	169	25	5.5	12	22.0 (2243)	55.0 (5610)	6000	11.5	0.060	S1246	2.80 (28.6)	HB06B1	SBO6L1A
BS308	52	210	18	7.5	14	34.8 (3549)	84.0 (8570)	5000	22.5	0.125	S1552	2.65 (27.0)	HB08B1	SBO8B1
BS310	75	254	33	9.1	17	43.0 (4385)	105.8 (10795)	4200	34.5	0.325	S1875	2.70 (27.5)	HB10AA1	SB10B1



CHUCK

Large Thru-Hole High Speed Power Chuck (Direct Mount) BS300A series

Equipped with Chuck Adaptor to suit Spindle Nose
Standard chuck for next generation



Standard Chuck

Dimensional Drawings

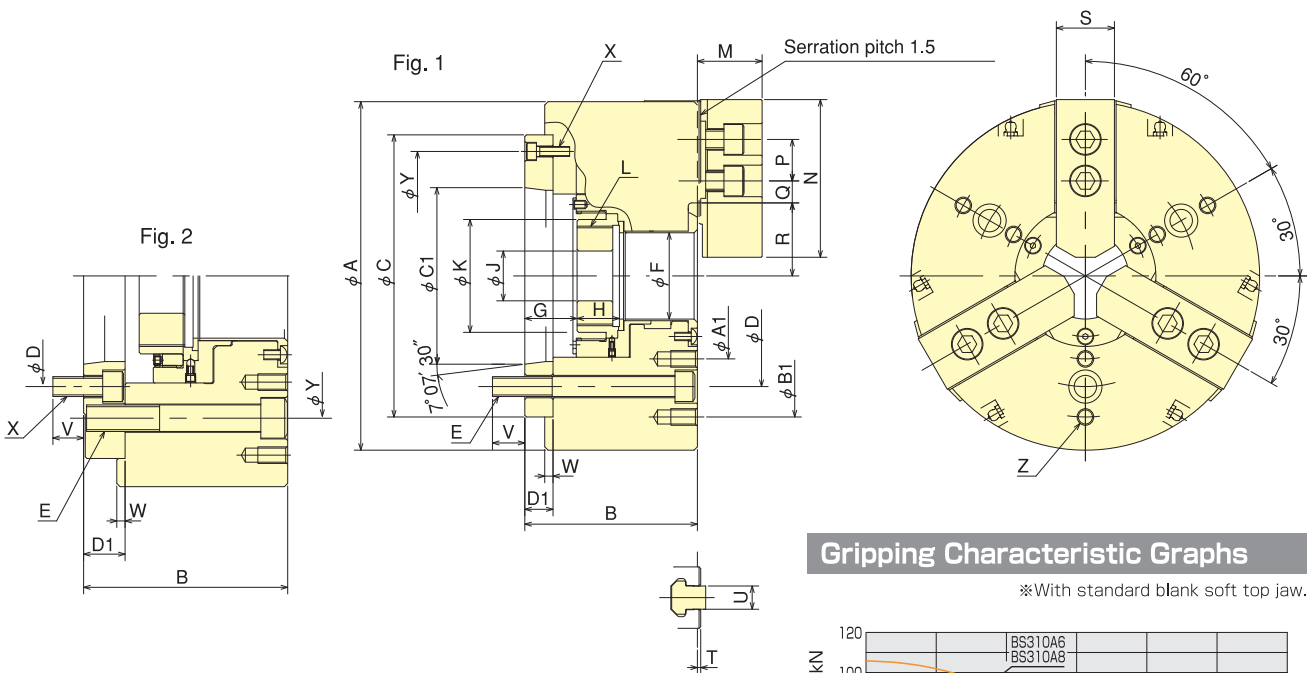

Gripping Characteristic Graphs

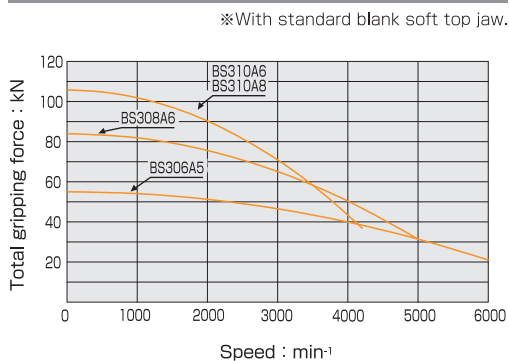

Dimensions

*BS310A6 is referred to in Fig.2. *Blank draw nut equipped.

Dimensions Model	A	B	C	D	E	F	G max.	G min.	H	J	K	L max.	M	N	P	Q max.	Q min.	R max.	R min.	S	T	U	V	W	X	Y	Z	A1	B1	C1	D1
BS306A5	169	95	140	104.8	3-M10	45	26	14	20	20	61	M55×2.0	29	66	20	21.25	9.25	35	32.25	26	2	12	16.5	5	3-M 6	116	3×2-M8	77.5	140	82.563	15
BS308A6	210	104	170	133.4	3-M12	52	31.5	17.5	25.5	30	68	M60×2.0	39	95	25	23.75	11.75	44	40.25	35	2	14	19.5	5	3-M 6	150	3×2-M10	100	170	106.375	17
BS310A6	254	123	220	133.4	3-M16	75	33.5	16.5	32.5	45	94	M85×2.0	43	110	30	30.75	11.25	55	50.45	40	2	16	18.5	5	6-M12	171.4	3×2-M10	128	216	106.375	18
BS310A8	254	116	220	171.4	3-M16	75	26.5	9.5	32.5	45	94	M85×2.0	43	110	30	30.75	11.25	55	50.45	40	2	16	25.2	5	3-M 8	190	3×2-M10	128	216	139.719	18

Specifications

Specifications Model	Thru-Hole mm	Gripping range mm Max.	Gripping range mm Min.	Jaw Stroke (diameter) mm	Plunger Stroke mm	Max Draw Bar Pul Force kN (kgf)	Max. Gripping Force kN (kgf)	Max. Speed min ⁻¹	Net Weight with Soft top jaws kg	Moment of inertia kg·m ²	Matching Cylinder	Max. pressure MPa(kgf/cm ²)	Matching Hard top jaw	Matching Soft top jaw	Spindle nose size
BS306A5	45	169	25	5.5	12	22.0(2243)	55.0 (5610)	6000	12.7	0.063	S1246	2.80(28.6)	HB06B1	SB06L1A	A2-5
BS308A6	52	210	18	7.5	14	34.8(3549)	84.0 (8570)	5000	24.4	0.135	S1552	2.65(27.0)	HB08A1	SB08B1	A2-6
BS310A6	75	254	33	9.1	17	43.0(4385)	105.8(10795)	4200	40.3	0.368	S1875	2.70(27.5)	HB10A1	SB10B1	A2-6
BS310A8	75	254	33	9.1	17	43.0(4385)	105.8(10795)	4200	37.8	0.353	S1875	2.70(27.5)	HB10A1	SB10B1	A2-8



CHUCK

Lever Style Power Chuck BL-200 series

Extra Long Jaw Stroke Flange work securely gripped

*CE correspondence



Dimensional Drawings

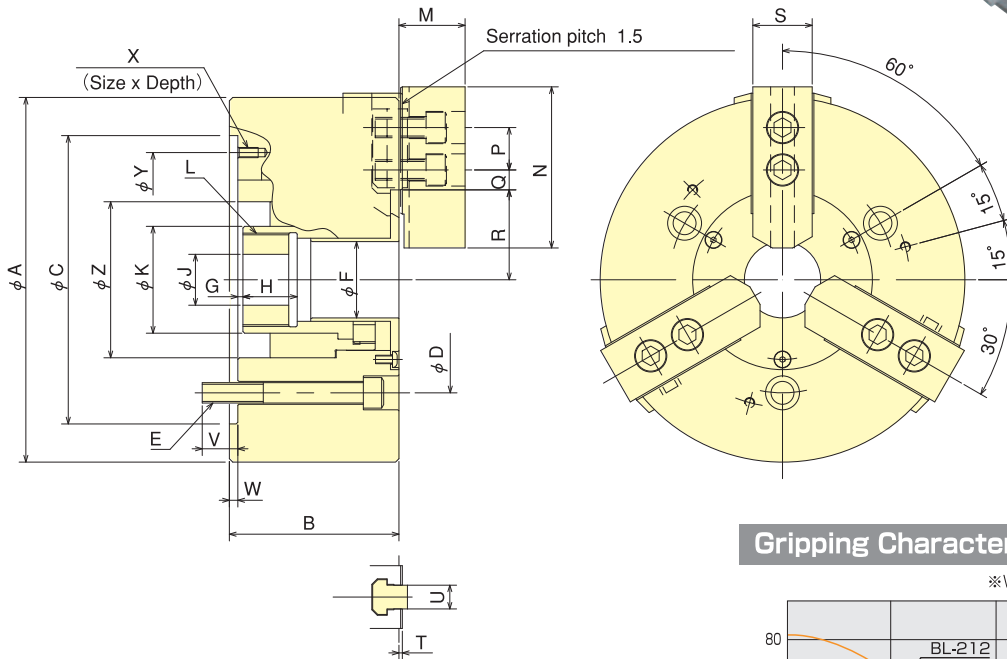

Gripping Characteristic Graphs

*With standard blank soft top jaw.

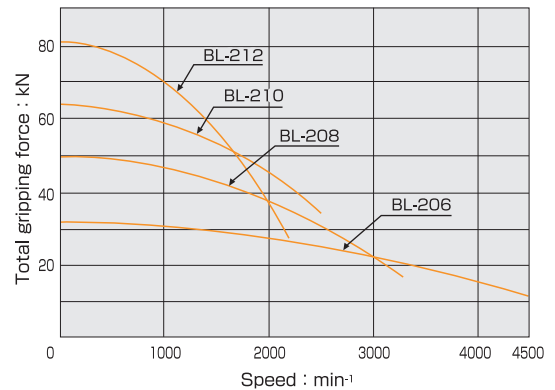

Dimensions *Blank draw nut equipped.

Dimensions Model	A	B	C (H6)	D	E	F	G max.	G min.	H	J	K	L max.	M	N	P	Q max.	Q min.	R max.	R min.	S	T	U	V	W	X (3-)	Y	Z
BL-206	165	87	140	104.8	3-M10	28	10	-5	24	20	45	M38x1.5	29	66	20	16.75	9.25	39.25	29.25	26	2	12	16	5	M6x12	116	70
BL-208	215	100	170	133.4	3-M12	45	3	-16	32	30	63	M55x2.0	39	95	25	20.75	11.75	53	40.5	35	2	14	21	5	M6x12	150	92
BL-210	254	117	220	171.4	3-M16	53	-6	-28	40	45	73	M65x2.0	43	110	30	26.25	11.25	62.5	47.5	40	2	16	27	5	M8x16	190	102
BL-212	304	138	220	171.4	3-M16	63	8.2	-16.8	38	50	83	M75x2.0	52	111	30	38.25	12.75	74.5	57	50	3	21	23	5	M8x16	190	120

Specifications

Specifications Model	Thru-Hole mm	Gripping range mm Max.	Gripping range mm Min.	Jaw Stroke (diameter) mm	Plunger Stroke mm	Max. Draw Bar Pull Force kN (kgf)	Max. Gripping Force kN (kgf)	Max. Speed min⁻¹	Net Weight kg	Moment of inertia kg·m²	Matching Cylinder	Max. pressure MPa (kgf/cm²)	Matching Hard top jaw	Matching Soft top jaw
BL-206	28	165	28	20	15	27.9 (2845)	31.2 (3182)	4500	14.0	0.043	S1246	3.40 (34.7)	HB06B1	SB06L1A
BL-208	45	215	32	25	19	41.1 (4191)	49.0 (4997)	3300	25.0	0.198	S1552	2.99 (30.5)	HB08A1	SB08B1
BL-210	53	254	42	30	22	53.8 (5486)	63.0 (6424)	3000	45.0	0.306	S1875	3.20 (32.6)	HB10A1	SB10B1
BL-212	63	304	43	35	25	69.3 (7067)	80.4 (8199)	2200	78.0	0.918	S2091	3.22 (32.8)	HB12N1	SB12N1



CHUCK

Lever Style Power Chuck (Direct Mount) BL200A series

Chuck Adaptor is equipped to suit Spindle Nose Flange work securely gripped

* CE correspondence



Dimensional Drawings

Fig.2

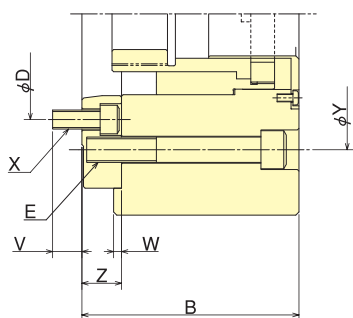
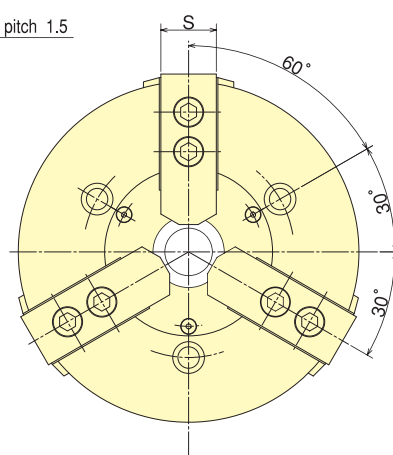
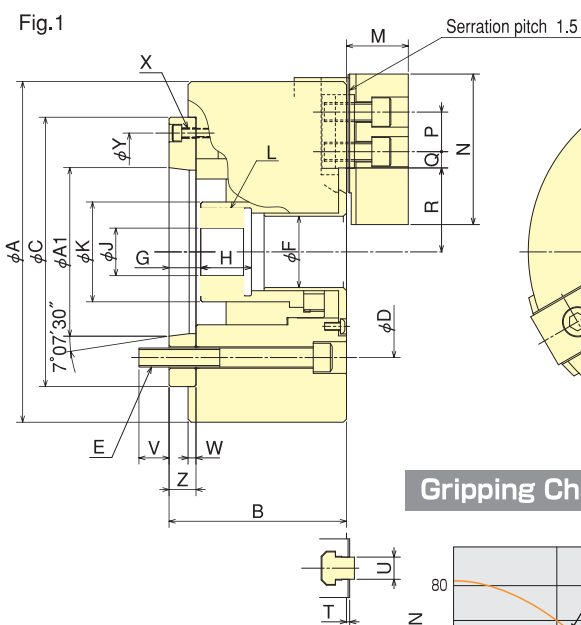
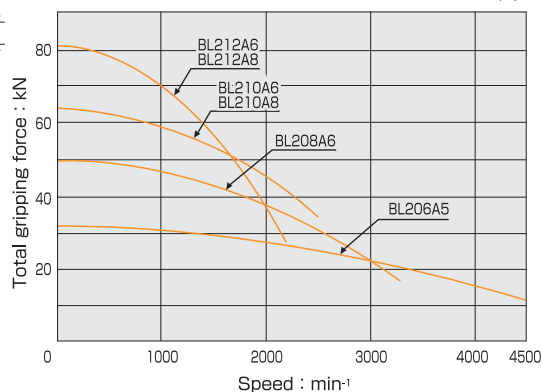

Fig.1



Gripping Characteristic Graphs

*With standard blank soft top jaw.



Dimensions

*BL210A6 and BL212A6 are based on Fig. 2. *Blank draw nut equipped.

Dimensions Model	A	B	C	D	E	F	G max.	G min.	H	J	K	L max.	M	N	P	Q max.	Q min.	R max.	R min.	S	T	U	V	W	X	Y	Z	A1
BL206A5	165	97	140	104.8	3-M10	28	25	10	24	20	45	M38x1.5	29	66	20	16.75	9.25	39.25	29.25	26	2	12	16	5	3-M6	116	15	82.563
BL208A6	215	112	170	133.4	3-M12	45	20	1	32	30	63	M55x2.0	39	95	25	20.75	11.75	53	40.5	35	2	14	19	5	3-M6	150	17	106.375
BL210A6	254	137	220	133.4	3-M16	53	19	-3	40	45	73	M65x2.0	43	110	30	26.25	11.25	62.5	47.5	40	2	16	18.5	5	6-M12	171.4	25	106.375
BL210A8	254	130	220	171.4	3-M16	53	12	-10	40	45	73	M65x2.0	43	110	30	26.25	11.25	62.5	47.5	40	2	16	24	5	3-M8	190	18	139.719
BL212A6	304	158	220	133.4	3-M16	63	33.2	8.2	38	50	83	M75x2.0	52	111	30	38.25	12.75	74.5	57	50	3	21	18.5	5	6-M12	171.4	25	106.375
BL212A8	304	151	220	171.4	3-M16	63	26.2	1.2	38	50	83	M75x2.0	52	111	30	38.25	12.75	74.5	57	50	3	21	25	5	3-M8	190	18	139.719

Specifications

Specifications Model	Thru-Hole mm	Gripping range mm Max.	Gripping range mm Min.	Jaw Stroke (diameter) mm	Plunger Stroke mm	Max. Draw Bar Pull Force kN (kgf)	Max. Gripping Force kN (kgf)	Max. Speed min⁻¹	Net Weight kg	Moment of inertia kg·m²	Matching Cylinder	Max. pressure MPa (kgf/cm²)	Matching Hard top jaw	Matching Soft top jaw
BL206A5	28	165	28	20	15	27.9 (2845)	31.2 (3182)	4500	15.2	0.048	S1246	3.40 (34.7)	HB06B1	SB06L1A
BL208A6	45	215	32	25	19	41.1 (4191)	49.0 (4997)	3300	26.0	0.208	S1552	2.99 (30.5)	HB08A1	SB08B1
BL210A6	53	254	42	30	22	53.8 (5486)	63.0 (6424)	3000	50.5	0.351	S1875	3.20 (32.6)	HB10A1	SB10B1
BL210A8	53	254	42	30	22	53.8 (5486)	63.0 (6424)	3000	48.0	0.325	S1875	3.22 (32.6)	HB10A1	SB10B1
BL212A6	63	304	43	35	25	69.3 (7067)	80.4 (8199)	2200	78.0	0.918	S2091	3.22 (32.8)	HB12N1	SB12N1
BL212A8	63	304	43	35	25	69.3 (7067)	80.4 (8199)	2200	81.2	0.943	S2091	3.22 (32.8)	HB12N1	SB12N1



CHUCK

Counter Balanced Power Chuck HOH series

Counter Balance Design Secure gripping at high speeds

*CE correspondence



Dimensional Drawings

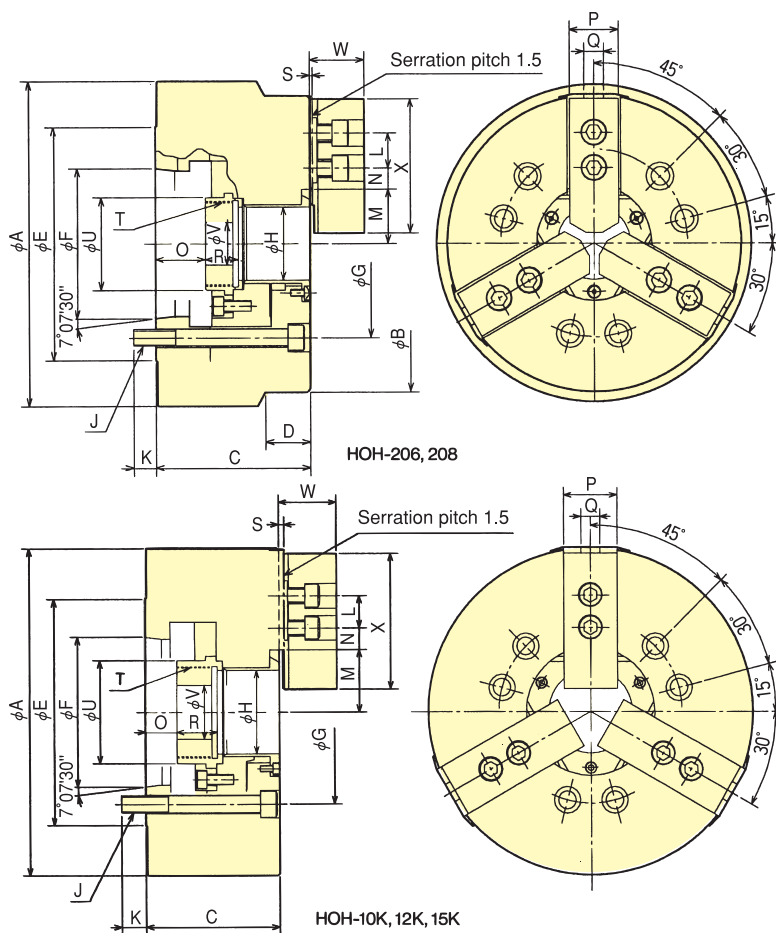

Gripping Characteristic Graphs

*With standard blank soft top jaw.

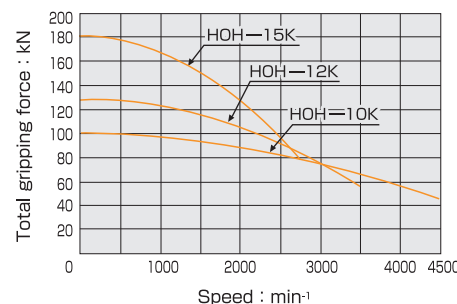
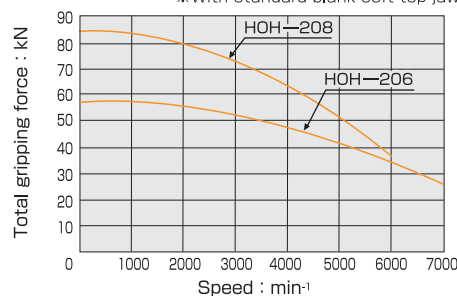

Dimensions *Blank draw nut equipped.

Dimensions	A	B	C	D	E	F	G	H	J	K	L	M	M	N	N	O	O	P	Q	R	S	T	U	V	W	X
Model												max.	min.	max.	min.	max.	min.					max.				
HOH-206	175	169	95	322	135	82.563	104.8	45	6-M10	17	20	32	29.25	22.75	9.25	30	18	26	12	19	2	M55×2	60	20	29	66
HOH-208	230	210	110	32	165	106.375	133.4	52	6-M12	16	25	38.7	35	29.75	14.75	35.5	19.5	35	14	23.5	2	M60×2	66	30	39	95
HOH-10K	254	-	114	-	210	139.719	171.4	65	6-M16	24	30	50	45.6	32.25	12.75	14	-5	40	16	35	5	M75×2	84.5	45	46	110
HOH-12K	304	-	125	-	210	139.719	171.4	78	6-M16	23	30	58	52.7	48.75	14.25	29	6	50	18	38	5	M88×2	96	50	54	129
HOH-15K	381	-	154	-	280	196.869	235	117.5	6-M20	30	43	82	76.7	43.75	18.25	38	15	62	22	39	5	M130×2	139	60	70	165

Specifications *Max speed is shown using actual test data.

Specifications	Thru-Hole	Gripping range	Jaw Stroke	Plunger	Max. Draw Bar	Max. Gripping	Max. Speed	Net Weight with	Moment of inertia	Matching	Max. pressure	Max. pressure	Matching	Spindle
Model	mm	Max. Min.	(diameter)	Stroke	Pull Force	Force	min⁻¹	Soft top jaws	kg·m²	Cylinder	MPa(kgf/cm²)	MPa(kgf/cm²)	Soft top jaw	nose size
HOH-206	45	169 16	5.5	12	22.0 (2243)	57.0 (5812)	7000	15.7	0.068	S1246	2.80 (28.5)	HB06B1	SB06L1A	A2 - 5
HOH-208	52	210 13	7.4	16	34.0 (3467)	84.0 (8566)	6000	29.0	0.193	S1552	2.60 (26.5)	HB08A1	SB08B1	A2 - 6
HOH-10K	65	254 25	8.8	19	38.0 (3875)	99.0 (10095)	4500	40.0	0.350	S1875	2.30 (23.5)	HB10A1	SB10B1	A2 - 8
HOH-12K	78	304 23	10.6	23	49.0 (4997)	129.0 (13154)	3500	67.0	0.875	S2091	2.30 (23.5)	HB12N1	SB12A1	A2 - 8
HOH-15K	117.5	381 30	10.6	23	71.0 (7240)	180.0 (18355)	2800	124.0	2.550	F2511H	2.30 (23.5)	HB15A1	SB15C1	A2 -11



CHUCK

Quick Jaw-Change Chuck QB300 series

Easy set-up and Quick Change of Top Jaw

* CE correspondence



Standard Chuck

Dimensional Drawings

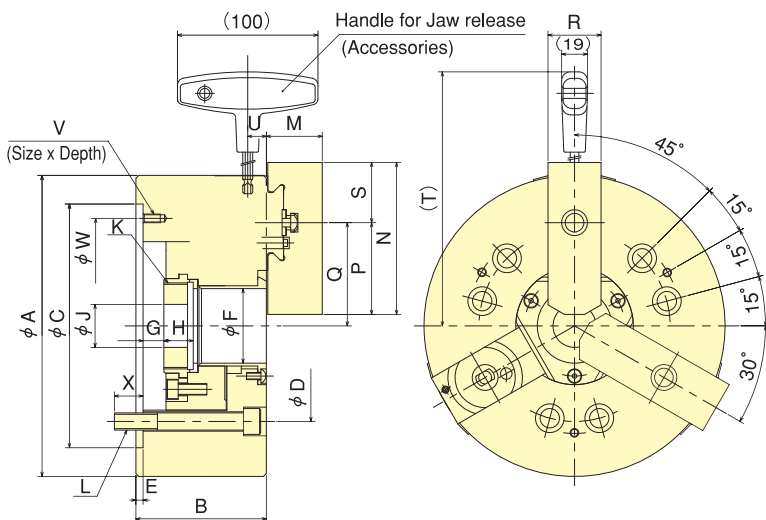

Gripping Characteristic Graphs

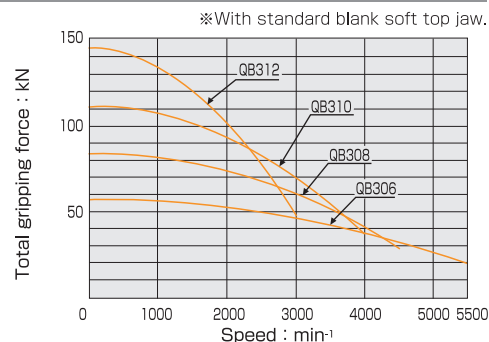

Note) Please contact our engineering regarding casting and forgin material machining.

Dimensions *Blank draw nut equipped.

Dimensions Model	A	B	C (H6)	D	E	F	G max.	G min.	H	J	K max.	L	M	N	P	Q max.	Q min.	R	S	T	U	V	W	X
QB306	169	81	140	104.8	5	45	11	-1	19	20	M55x2.0	6-M10	31	90	54	58.5	55.75	32	36	192.5	13	M6x10	116	16
QB308	210	91	170	133.4	5	52	14.5	-1.5	20.5	30	M60x2.0	6-M12	39	106	64	72	68.3	37	42	220.7	13	M6x12	150	20
QB310	254	100	220	171.4	5	75	8.5	-10.5	25	45	M85x2.0	6-M16	43	125	76	88	83.6	42	49	242	15.5	M8x15	190	22
QB312	304	110	220	171.4	6	91	8	-15	28	50	M100x2.0	6-M16	51	139	90	106.3	101	42	49	267	15.5	M8x15	190	23

Specifications *Max speed is shown using actual test data.

Specifications Model	Thru-Hole mm	Outer gripping range mm	Jaw Stroke (diameter) mm	Plunger Stroke mm	Max. Draw Bar Pull Force kN (kgf)	Max. Gripping Force kN (kgf)	Max. Speed min ⁻¹	Net Weight with Soft top jaws kg	Moment of inertia kg·m ²	Matching Cylinder	Max. pressure MPa (kgf/cm ²)	Matching Soft top jaw
QB306	45	φ10~φ140	5.5	12	22.0 (2243)	57.0 (5812)	5500	12.6	0.058	S1246	2.80 (28.6)	SB06BB
QB308	52	φ18~φ180	7.4	16	34.0 (3467)	84.0 (8565)	4500	23.2	0.173	S1552	2.60 (26.5)	SB08BB
QB310	75	φ22~φ210	8.8	19	43.0 (4385)	111.0 (11319)	4000	35.0	0.318	S1875	2.70 (27.5)	SB10BB
QB312	91	φ30~φ250	10.6	23	55.0 (5608)	144.0 (14684)	3000	56.0	0.745	S2091	2.70 (27.5)	SB12BB

Soft Top Jaw Dimensional Drawings

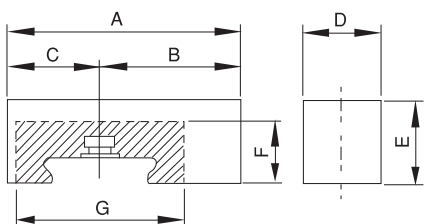

Note) No modification is allowed in shaded area.

Dimensions for Soft Top Jaw

Soft Jaw Model Dimensions	6"		8"		10"		12"	
	SB06BB	SB06BB-040	SB08BB	SB08BB-056	SB10BB	SB10BB-060	SB12BB	SB12BB-070
A	90	90	106	106	125	125	139	139
B	54	54	64	64	76	76	90	90
C	36	36	42	42	49	49	49	49
D	32	32	37	37	42	42	42	42
E	30	40	38	56	42	60	50	70
F	24	24	28	28	31	31	34	34
G	68	68	76	76	88	88	92	92
Min. gripper range	10	10	18	18	22	22	30	30



CHUCK

Quick Jaw Replacement Chuck

QJR series

Suitable for small and large batch production Quick & smooth Jaw Replacement

Quick Jaw Replacement

2 types of easy replacement jaws, Serration and Tongue & Groove, are available as options. Jaw can be replaced quickly and easily by handle supplied.

Suitable for small and large batch production

Reduced set up time by Quick and Easy Jaw Replacement.

Interchangeable mounting dimensions

Kitagawa's B-200 and BB200 series can be easily replaced with QJR large thru-hole power chucks.



Standard Chuck

Dimensional Drawings

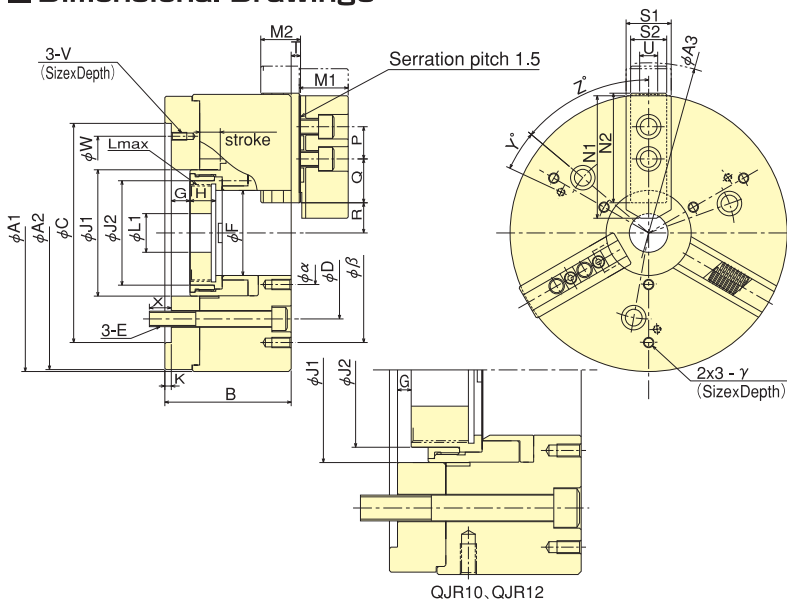

Gripping Characteristic Graphs

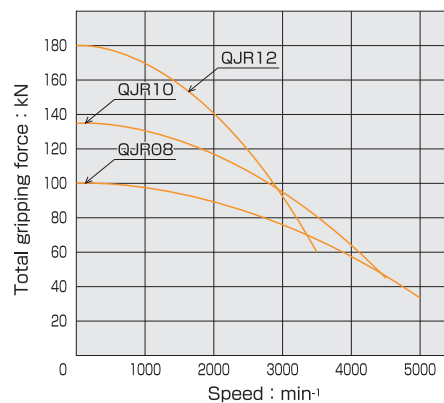

※Graphs show the relationship between the rotation speed and the gripping force at the position of aligning base jaws with chuck OD when using standard soft jaws.
※Centrifugal force is different vastly depending on the size, shape or orientation of top jaws, or the position to insert base jaws.

Dimensions

Model	A1	A2	A3	B	C (H6)	D	E	F	G max.	G min.	H	J1	J2	K	L max.	L1	M1	M2	N1
QJR08	215	212	264	98	170	133.4	M12	66	14.5	-1.5	20	98	81	5	M75x2	30	38	30.8	95
QJR10	254	251	312	119	220	171.4	M16	81	8.5	-10.5	39	115	96	5	M90x2	45	42	39.0	110
QJR12	315	312	360	133	220(300)	171.4(235)	M16(M20)	106	8.0	-15.0	42	140	121	6	M115x2	50	50	45.2	111

Model	N2	P	Q	R max.	R min.	S1	S2	T	U	V	W	X	Y	Z	α	β	γ
QJR08	85.0	25	34.0	20.4-44.4	16.7-40.7	35	28	7.25	14	M6x12	150	17	15	50	80	170	M8x15
QJR10	100.5	30	40.5	21.2-52.7	16.8-48.3	40	35	11.30	16	M8x15	190	23	-15	50	100	220	M8x15
QJR12	108.0	30	57.0	33.9-69.9	28.6-64.6	50	50	12.00	21	M8x15(M10x16)	190(260)	22(27)	-15	45(50)	130	280	M10x17

Specifications

The numbers in () are the dimension of QJR12 for interchangeable BB212. Please contact us for more details.

Model	Thru-Hole mm	Gripping range mm		Jaw Stroke (diameter) mm	Plunger Stroke mm	Max. Draw Bar Pull Force kN	Max. Gripping Force kN	Max. Speed min ⁻¹	Net Weight with Soft top jaws kg	Moment of inertia kg·m ²	Matching Base Jaw	Matching Soft top jaw
		Max.	Min.									
QJR08	66	210	23	7.4	16	45	100	5000	25	0.18	QJR08-BJ00	SBO8B1
QJR10	81	254	41	8.8	19	60	135	4500	45	0.41	QJR10-BJ00	SB10B1
QJR12	106	315	47	10.6	23	81	180	3500	75	1.15	QJR12-BJ00	SB12N1

The models above are including Chuck body, 1 set of Base Jaws and 1 set of Soft Top Jaws.



CHUCK

2 Jaw Large Thru-Hole High Speed Power Chuck BT200 series

For gripping Irregular shaped components

* CE correspondence



Standard Chuck

Gripping Examples

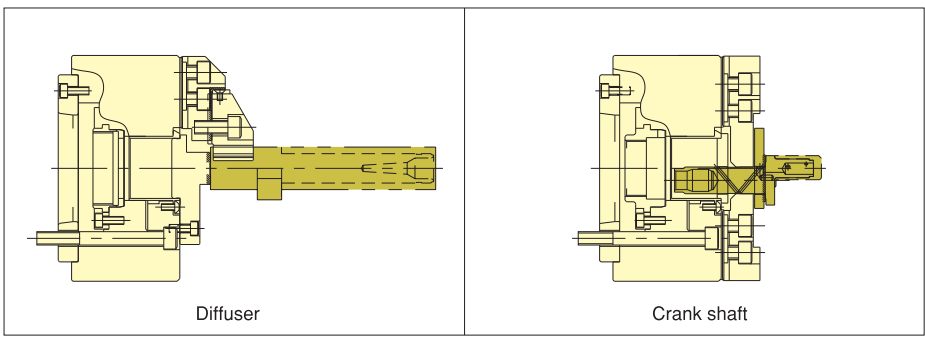

Dimensional Drawings

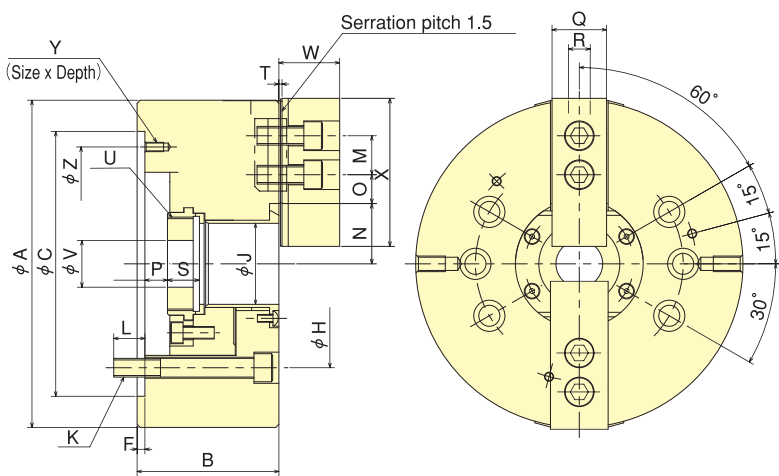

Gripping Characteristic Graphs

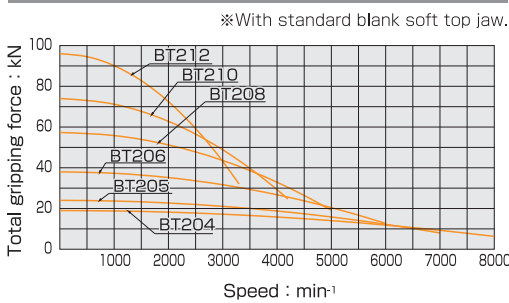

Dimensions ※Mounting bolt P. C. D. for BT204 & BT205 : each 60° from jaw centre : 4 pcs. ※Blank draw nut equipped.

Model	A	B	C (H6)	F	H	J	K	L	M	N max.	N min.	O max.	O min.	P max.	P min.	Q	R	S	T	U max.	V	W	X	Y	Z
BT204	110	59	85	4	70.6	26	4-M10	15.5	14	23	20.3	11.25	6.75	3.5	- 6.5	23	10	17.5	2	M32×1.5	12	24	49.5	-	-
BT205	135	60	110	4	82.55	33	4-M10	15	14	26.5	23.8	19.75	7.75	1	- 9	23	10	20	2	M40×1.5	12	26	54	-	-
BT206	169	81	140	5	104.8	45	6-M10	16	20	32	29.25	22.75	9.25	11	- 1	26	12	19	2	M55×2.0	20	29	66	M6×10	116
BT208	210	91	170	5	133.4	52	6-M12	20	25	38.7	35	30	15	14.5	- 1.5	35	14	20.5	2	M60×2.0	30	39	95	M6×12	150
BT210	254	100	220	5	171.4	75	6-M16	22	30	51	46.6	34	14.5	8.5	- 10.5	40	16	25	2	M85×2.0	45	43	110	M8×15	190
BT212	304	110	220	6	171.4	91	6-M16	23	30	61.3	56	45.75	15.75	8	- 15	50	21	28	2	M100×2.0	50	51	111	M8×15	190

Specifications

※Max speed is shown using actual test data.

Model	Thru-Hole mm	Gripping range mm Max. Min.	Jaw Stroke (diameter) mm	Plunger Stroke mm	Max. Draw Bar Pull Force kN (kgf)	Max. Gripping Force kN (kgf)	Max. Speed minr ⁻¹	Net Weight with Soft top jaws kg	Moment of inertia kg·m ²	Matching Cylinder	Max. pressure MPa (kgf/cm ²)	Matching Soft top jaw
BT204	26	110 7	5.4	10	9.3 (948)	19.0(1937)	8000	3.8	0.006	F0933H	1.94 (19.8)	SB04N1T
BT205	33	135 12	5.4	10	11.7 (1193)	24.0(2447)	7000	6.5	0.017	F0933H	2.38 (24.3)	SB05N1T
BT206	45	169 14	5.5	12	14.5 (1479)	38.0(3875)	6000	11.5	0.056	S1246	1.85 (18.9)	SB06L1T
BT208	52	210 14	7.4	16	23.2 (2366)	57.3(5843)	5000	21.3	0.165	S1552	1.80 (18.4)	SB08A1T
BT210	75	254 31	8.8	19	28.5 (2906)	74.0(7546)	4200	33.5	0.308	S1875	1.80 (18.4)	SB10A1T
BT212	91	304 34	10.6	23	36.7 (3742)	96.0(9789)	3300	52.0	0.700	S2091	1.81 (18.5)	SB12N1T

※Altering Back Plate enables to change over 3-Jaw Chuck into 2-Jaw Chuck.



CHUCK

2-Jaw Large Thru-Hole Power Chuck BBT200 series

For gripping the Irregular shaped components
2-Jaw type of BB200 series



- Large thru-hole
6 inch ϕ 53 · 8 inch ϕ 66
10 inch ϕ 81 · 12 inch ϕ 106
- *CE correspondence

Standard Chuck

Dimensional Drawings

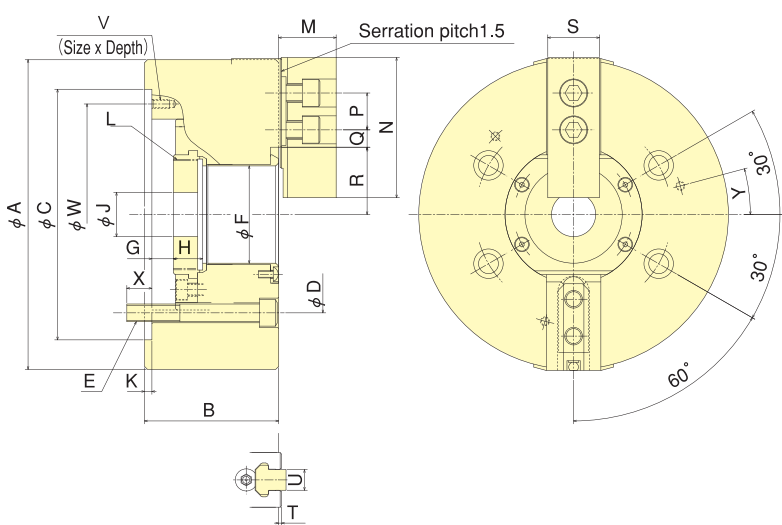

Gripping Characteristic Graphs

※With standard blank soft top jaw.

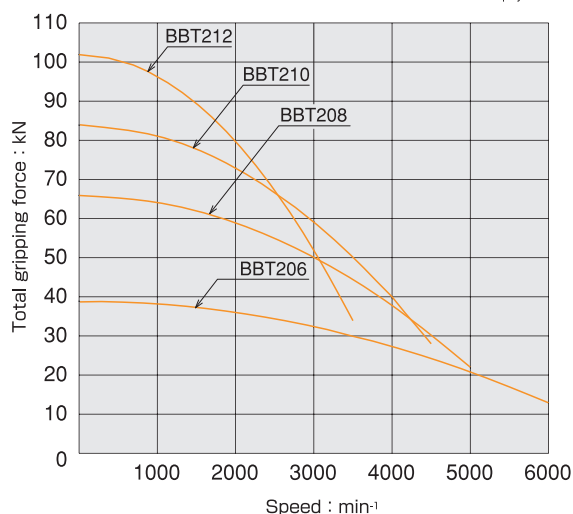

Dimensions

※Blank draw nut equipped.

Dimensions Model	A	B	C (H6)	D	E	F	G max.	G min.	H	J	K	L max.	M	N	P	Q max.	Q min.	R max.	R min.	S	T	U	V	W	X	Y
BBT206	170	81	140	104.8	4-M10	53	11.0	-1.0	17.5	20	5	M60x2.0	33.2	72	20	21.25	10.75	36.0	33.25	31	2.0	12	M6x10	116	16	0°
BBT208	210	91	170	133.4	4-M12	66	14.5	-1.5	20.0	30	5	M75x2.0	39.0	95	25	24.00	12.00	45.7	42.00	35	2.0	14	M6x12	150	17	15°
BBT210	254	100	220	171.4	4-M16	81	8.5	-10.5	25.0	45	5	M90x2.0	43.2	110	30	32.50	14.50	54.0	49.60	40	2.0	16	M8x15	190	22	15°
BBT212	315	108	300	235.0	4-M20	106	8.0	-15.0	28.0	50	6	M115x2.0	51.7	111	30	45.75	15.75	67.8	62.50	50	2.5	21	M10x16	260	29	15°

Specifications

Specifications Model	Thru-Hole mm	Gripping range mm Max. Min.	Jaw Stroke (diameter) mm	Plunger Stroke mm	Max. Draw Bar Pull Force kN (kgf)	Max. Gripping Force kN (kgf)	Max. Speed min⁻¹	Net Weight with Soft top jaws kg	Moment of inertia kg·m²	Matching Cylinder	Max. pressure MPa (kgf/cm²)	Matching Soft top jaw
BBT206	53	170 19	5.5	12	13.3 (1356)	38.9 (3967)	6000	11.4	0.048	SS1453K	1.33 (13.6)	SB06A1T
BBT208	66	210 23	7.4	16	21.3 (2172)	65.9 (6720)	5000	21.5	0.137	SS1666K	1.64 (16.7)	SB08A1T
BBT210	81	254 41	8.8	19	32.5 (3314)	83.9 (8555)	4500	30.8	0.292	SS1881K	2.14 (21.8)	SB10A1T
BBT212	106	315 47	10.6	23	39.3 (4007)	101.9 (10391)	3500	50.2	0.706	SS2110K	2.05 (20.9)	SB12N1T

※Altering Back Plate enables to change over 3-Jaw Chuck into 2-Jaw Chuck.



CHUCK

2-Jaw Lever Style Power Chuck BLT200 series

Extra Long Jaw Stroke for gripping Irregular shaped components
Flange work securely gripped

* CE correspondence



Standard Chuck

Gripping Examples

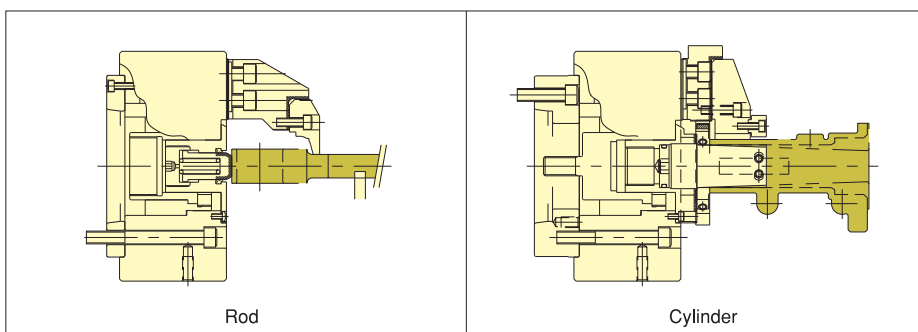

Rod

Cylinder

Dimensional Drawings

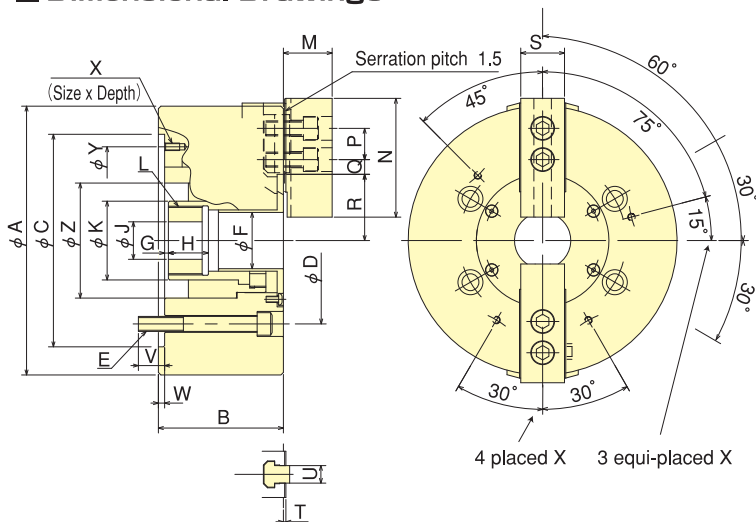

Gripping Characteristic Graphs

*With standard blank soft top jaw.

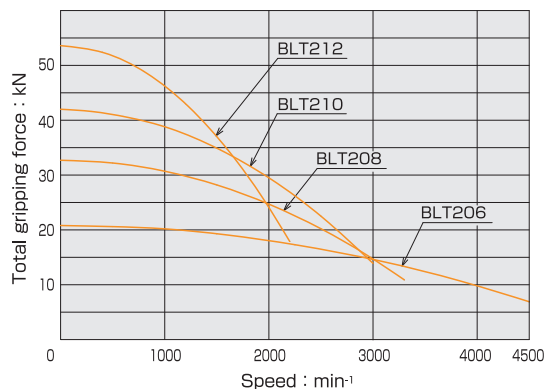

Dimensions

*Blank draw nut equipped.

Model	A	B	C (H6)	D	E	F	G max.	G min.	H	J	K	L max.	M	N	P	Q max.	Q min.	R max.	R min.	S	T	U	V	W	X	Y	Z
BLT206	165	87	140	104.8	4-M10	28	10	-5	24	20	45	M38x1.5	29	66	20	16.75	9.25	39.25	29.25	26	2	12	16	5	4-M6x12	116	70
BLT208	215	100	170	133.4	4-M12	45	3	-16	32	30	63	M55x2.0	39	95	25	21	12	53	40.5	35	2	14	21	5	3-M6x12	150	92
BLT210	254	117	220	171.4	4-M16	53	-6	-28	40	45	73	M65x2.0	43	110	30	26.5	11.5	62.5	47.5	40	2	16	27	5	3-M8x16	190	102
BLT212	304	138	220	171.4	4-M16	63	8.2	-16.8	38	50	83	M75x2.0	52	111	30	38.25	12.75	74.5	57	50	3	21	23	5	3-M8x16	190	120

Specifications

Model	Thru-Hole mm	Gripping range mm Max. Min.	Jaw Stroke (diameter) mm	Plunger Stroke mm	Max. Draw Bar Pull Force kN (kgf)	Max. Gripping Force kN (kgf)	Max. Speed min⁻¹	Net Weight kg	Moment of inertia kg·m²	Matching Cylinder	Max. pressure MPa(kgf/cm²)	Matching Hard top jaw	Matching Soft top jaw
BLT206	28	165 28	20	15	18.6 (1897)	20.8 (2121)	4500	13.5	0.042	S1246	2.36 (24.1)	HB06B1	SB06L1T
BLT208	45	215 32	25	19	27.4 (2794)	32.7 (3334)	3300	24.0	0.193	S1552	2.08 (21.2)	HB08A1	SB08A1T
BLT210	53	254 42	30	22	35.9 (3661)	42.0 (4283)	3000	43.5	0.290	S1875	2.20 (22.4)	HB10A1	SB10A1T
BLT212	63	304 43	35	25	46.2 (4711)	53.6 (5465)	2200	75.5	0.903	S2091	2.22 (22.6)	HB12N1	SB12N1T

*Altering Back Plate enables to change over 3-Jaw Chuck into 2-Jaw Chuck.



CHUCK

Closed Centre Power Chuck

N series

Closed Centre Standard Chuck

The standard Closed Centre chuck

* CE correspondence



Dimensional Drawings

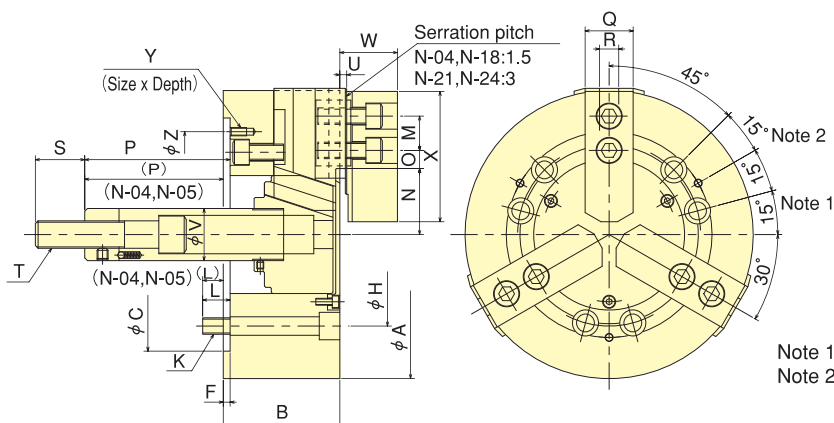

Gripping Characteristic Graphs

※With standard blank soft top jaw.

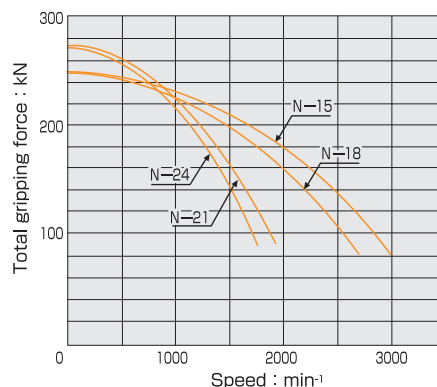
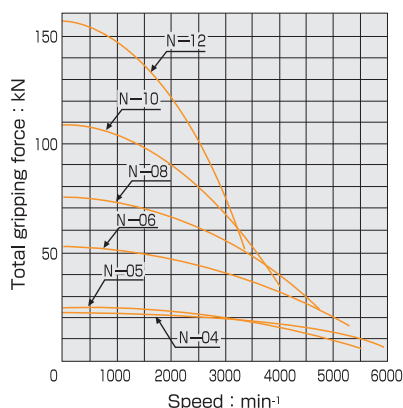

Dimensions

※Mounting bolt P. C. D. for N-04 & N-05 : 120° pitch : 3 pcs. ※Mounting bolt P. C. D. for N-21 & N-24 : 60° pitch : 6 pcs.

Dimensions Model	A	B	C (H6)	F	H	J	K	L	M	N max.	N min.	O max.	O min.	P max.	P min.	Q	R	S	T	U	V	W	X	Y	Z
N-04	110	52	60	6	80	-	3-M8	12	14	23.3	20.1	11.25	8.25	18	3	23	10	25	M10x1.5	3	26	27	55	-	-
N-05	135	55	80	7	100	-	3-M8	14	19	30.4	27.2	11.25	6.75	9	-6	23	10	35	M12x1.75	3	28	29	62	-	-
N-06	165	74	140	5	104.8	21	6-M10	14	20	37.8	33.55	13.75	7.75	101.5	81.5	31	12	36	M16x2.0	4	34	35	72	M6x10	116
N-08	210	85	170	5	133.4	25	6-M12	20	25	46.3	41.9	22.25	11.75	127	106	35	14	36	M20x2.5	5	38	42	95	M6x12	150
N-10	254	89	220	5	171.4	34	6-M16	18	30	51.1	46.7	30.75	11.25	158	133	40	16	36	M20x2.5	5	45	46	110	M8x15	190
N-12	304	106	220	6	171.4	34	6-M16	18	30	61	55.75	48.75	12.75	163	133	50	18	36	M20x2.5	5	50	54	129	M8x15	190
N-15	381	114	300	6	235.0	-	6-M20	30	43	77.5	69.5	48.75	23.25	104	69	50	25.5	55	M30x3.5	2	60	61	135	M10x20	260
N-18	450	114	300	6	235.0	-	6-M20	30	43	108	100	48.75	23.25	92	57	50	25.5	55	M30x3.5	2	60	61	135	M10x20	260
N-21	530	125	380	6	330.2	-	6-M22	31	60	86	78	93.5	27.5	97	62	65	25	55	M30x3.5	3	60	71	180	M12x30	330.2
N-24	610	125	380	6	330.2	-	6-M22	31	60	125	117	93.5	27.5	97	62	65	25	55	M30x3.5	3	60	71	180	M12x30	330.2

Specifications

※Max. speed is shown using actual test data. ※For large type more than N-24, confer with KITAGAWA.

Specifications Model	Gripping range mm Max.	Gripping range mm Min.	Jaw Stroke (diameter) mm	Plunger Stroke mm	Max. Draw bar Pull Force kN (kgf)	Max. Gripping Force kN (kgf)	Max. Speed min ⁻¹	Net Weight with soft top jaws kg	Moment of inertia kg·m ²	Matching pressure	Cylinder air	Max. pressure MPa (kgf/cm ²)	Matching Hard top jaw	Matching Soft top jaw
N-04	110	8	6.4	15	8.2 (836)	22.8 (2325)	6000	4.1	0.008	Y0715R	AY-1315R	2.40 (24.5)	-	SB04B1
N-05	135	16	6.4	15	8.2 (836)	25.2 (2570)	5500	6.2	0.015	Y0715R	AY-1315R	2.40 (24.5)	HB05C1	SB05B1
N-06	165	19	8.5	20	18.0 (1835)	52.5 (5353)	5270	13.0	0.045	Y1020R	AY-1720R	2.60 (26.5)	HB06B1	SB06B1
N-08	210	23	8.8	21	25.0 (2549)	75.0 (7648)	4760	25.0	0.138	Y1225R	AY-2225R	2.50 (25.5)	HB08A1	SB08B1
N-10	254	24	8.8	25	29.0 (2957)	108.0 (11013)	4010	37.0	0.300	Y1225R	AY-2225R	2.80 (28.6)	HB10A1	SB10B1
N-12	304	26	10.5	30	41.0 (4181)	156.0 (15907)	3380	57.3	0.725	Y1530R	-	2.70 (27.5)	HB12B1	SB12A1
N-15	381	72	16	35	82.0 (8362)	249.0 (25391)	3040	96.0	1.800	Y2035R	-	3.20 (32.6)	HB15N1	SB15N1
N-18	450	133	16	35	82.0 (8362)	249.0 (25391)	2710	124.0	2.350	Y2035R	-	3.20 (32.6)	HB15N1	SB15N1
N-21	530	62	16	35	82.0 (8362)	273.0 (27838)	1940	180.0	4.800	Y2035R	-	3.20 (32.6)	HB18B2	SB18A2
N-24	610	152	16	35	82.0 (8362)	273.0 (27838)	1760	223.0	6.925	Y2035R	-	3.20 (32.6)	HB18B2	SB18A2



CHUCK

Closed Centre Power Chuck (Direct Mount)

N-A series

Chuck Adaptor is equipped to suit Spindle Nose Closed Centre standard chuck

* CE correspondence

Dimensional Drawings

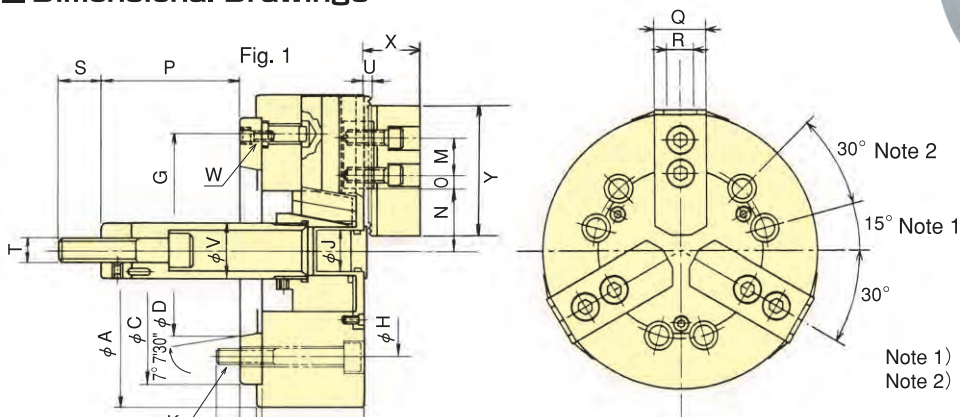

Standard Chuck

Gripping Characteristic Graphs

*With standard blank soft top jaw.

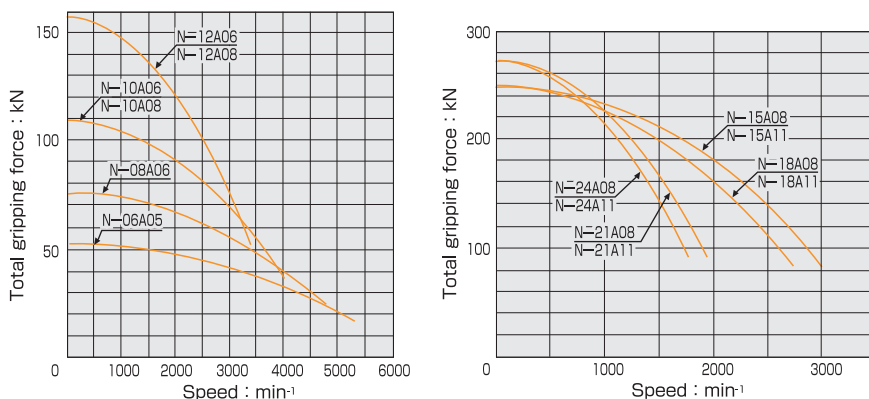

Dimensions *N-10A06, N-12A06, N-15A08, N-18A08, N-21A08, N-21A11, N-24A11 are referred to in Fig-2 *Mounting Bolt P.C.D for N-21A08~N-24A15: 60° Pitch: 6pcs..

Dimensions	A	B	C	D	E	F	G	H	J	K	L	M	N max.	N min.	O max.	O min.	P max.	P min.	Q	R	S	T	U	V	W	X	Y
N-06A05	165	84	140	82.563	15	5	116	104.8	21	6-M10	14	20	37.8	33.55	13.75	7.75	86.5	66.5	31	12	36	M16x2.0	4	34	3-M6	35	72
N-08A06	210	97	170	106.375	17	5	150	133.4	25	6-M12	18	25	46.3	41.9	22.25	11.75	110	89	35	14	36	M20x2.5	5	38	3-M6	42	95
N-10A06	254	104	220	106.375	20	5	171.4	133.4	34	6-M12	18	30	51.1	46.7	30.75	11.25	114	89	40	16	36	M20x2.5	5	45	6-M16	46	110
N-10A08	254	102	220	139.719	18	5	190	171.4	34	6-M16	25	30	51.1	46.7	30.75	11.25	140	115	40	16	36	M20x2.5	5	45	3-M8	46	110
N-12A06	304	120	220	106.375	20	6	171.4	133.4	34	6-M12	18	30	61	55.75	48.75	12.75	119	89	50	18	36	M20x2.5	5	50	6-M16	54	129
N-12A08	304	118	220	139.719	18	6	190	171.4	34	6-M16	25	30	61	55.75	48.75	12.75	145	115	50	18	36	M20x2.5	5	50	3-M8	54	129
N-15A08	381	130	300	139.719	22	6	235.0	171.4	-	6-M16	23	43	77.5	69.5	48.75	23.25	82	47	50	25.5	55	M30x3.5	2	60	6-M20	61	135
N-15A11	381	130	300	196.869	22	6	260	235.0	-	6-M20	33	43	77.5	69.5	48.75	23.25	82	47	50	25.5	55	M30x3.5	2	60	3-M10	61	135
N-18A08	450	130	300	139.719	22	6	235.0	171.4	-	6-M16	23	43	108	100	48.75	23.25	70	35	50	25.5	55	M30x3.5	2	60	6-M20	61	135
N-18A11	450	130	300	196.869	22	6	260	235.0	-	6-M20	33	43	108	100	48.75	23.25	70	35	50	25.5	55	M30x3.5	2	60	3-M10	61	135
N-21A08	530	146	380	139.719	27	6	330.2	171.4	-	6-M16	23	60	86	78	93.5	27.5	70	35	65	25	55	M30x3.5	3	60	6-M22	71	180
N-21A11	530	146	380	196.869	27	6	330.2	235.0	-	6-M20	28	60	86	78	93.5	27.5	70	35	65	25	55	M30x3.5	3	60	6-M22	71	180
N-21A15	530	146	380	285.775	27	6	330.2	330.2	-	6-M22	34	60	86	78	93.5	27.5	70	35	65	25	55	M30x3.5	3	60	3-M12	71	180
N-24A11	610	146	380	196.869	27	6	330.2	235.0	-	6-M20	28	60	125	117	93.5	27.5	70	35	65	25	55	M30x3.5	3	60	6-M22	71	180
N-24A15	610	146	380	285.775	27	6	330.2	330.2	-	6-M22	34	60	125	117	93.5	27.5	70	35	65	25	55	M30x3.5	3	60	3-M12	71	180

Specifications *Max. speed is shown using actual test data.

Specifications	Gripping range mm		Jaw Stroke (diameter) mm	Plunger Stroke mm	Max. Draw bar Pull Force kN (kgf)	Max. Gripping Force kN (kgf)	Max. Speed min ⁻¹	Net Weight with soft top jaws kg	Moment of inertia N·m ² (kg·m ²)	Matching pressure	Cylinder air	Max. pressure MPa (kgf/cm ²)	Matching Hard top jaw	Matching Soft top jaw	Spindle nose size
N-06A05	165	19	8.5	20	18.0 (1835)	52.5 (5353)	5270	14.0	0.050	Y1020R	AY1720R	2.60 (26.5)	HB06B1	SB06B1	A2-5
N-08A06	210	23	8.8	21	25.0 (2549)	75.0 (7648)	4760	27.0	0.148	Y1225R	AY2225R	2.50 (25.5)	HB08B1	SB08B1	A2-6
N-10A06	254	24	8.8	25	29.0 (2957)	108.0 (11013)	4010	40.0	0.335	Y1225R	AY2225R	2.80 (28.6)	HB10A1	SB10B1	A2-6
N-10A08	254	24	8.8	25	29.0 (2957)	108.0 (11013)	4010	40.0	0.328	Y1225R	AY2225R	2.80 (28.6)	HB10A1	SB10B1	A2-6
N-12A06	304	26	10.5	30	41.0 (4181)	156.0 (15907)	3380	67.0	0.760	Y1530R	-	2.70 (27.5)	HB12B1	SB12B1	A2-8
N-12A08	304	26	10.5	30	41.0 (4181)	156.0 (15907)	3380	66.0	0.753	Y1530R	-	2.70 (27.5)	HB12B1	SB12A1	A2-8
N-15A08	381	72	16	35	82.0 (8362)	249.0 (25391)	3040	105.0	1.950	Y2035R	-	3.20 (32.6)	HB15N1	SB15N1	A2-8
N-15A11	381	72	16	35	82.0 (8362)	249.0 (25391)	3040	103.0	1.875	Y2035R	-	3.20 (32.6)	HB15N1	SB15N1	A2-11
N-18A08	450	133	16	35	82.0 (8362)	249.0 (25391)	2710	134.0	2.475	Y2035R	-	3.20 (32.6)	HB15N1	SB15N1	A2-8
N-18A11	450	133	16	35	82.0 (8362)	249.0 (25391)	2710	131.0	2.425	Y2035R	-	3.20 (32.6)	HB15N1	SB15N1	A2-11
N-21A08	530	62	16	35	82.0 (8362)	273.0 (27838)	1940	201.0	5.175	Y2035R	-	3.20 (32.6)	HB18B2	SB18A2	A2-8
N-21A11	530	62	16	35	82.0 (8362)	273.0 (27838)	1940	198.0	5.125	Y2035R	-	3.20 (32.6)	HB18B2	SB18A2	A2-11
N-21A15	530	62	16	35	82.0 (8362)	273.0 (27838)	1940	190.0	4.975	Y2035R	-	3.20 (32.6)	HB18B2	SB18A2	A2-15
N-24A11	610	152	16	35	82.0 (8362)	273.0 (27838)	1760	241.0	7.375	Y2035R	-	3.20 (32.6)	HB18B2	SB18A2	A2-11
N-24A15	610	152	16	35	82.0 (8362)	273.0 (27838)	1760	234.0	7.050	Y2035R	-	3.20 (32.6)	HB18B2	SB18A2	A2-15



CHUCK

Large Power Chuck for Vertical Lathes

NV series

Low maintenance Power Chuck for Vertical Lathes Sealed Base Jaw to prevent Swarf and Coolant ingress



- Protection against Swarf and Coolant Protector and Scraper at Base Jaw prevent Swarf and Coolant ingress.

- Standard Jaw NV series is compatible with standard Hard and Soft Jaws as sealing is at the Base Jaw.

*CE correspondence

Dimensional Drawings

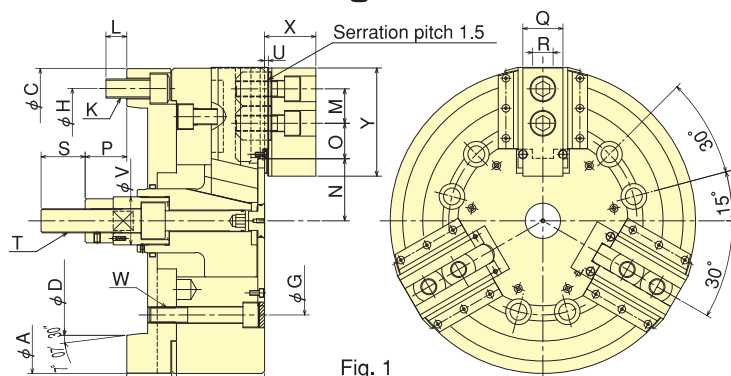

Fig. 1

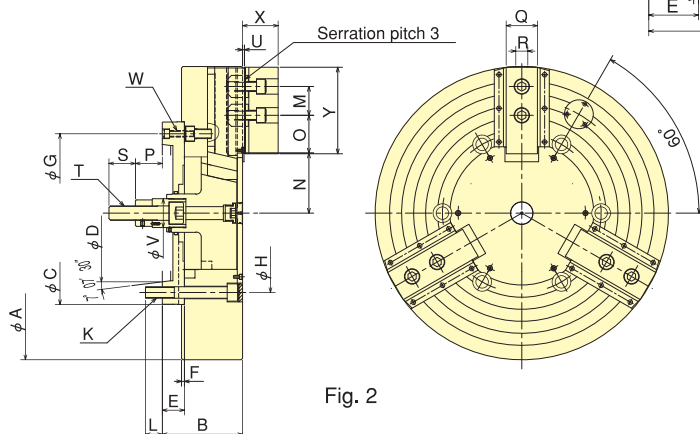
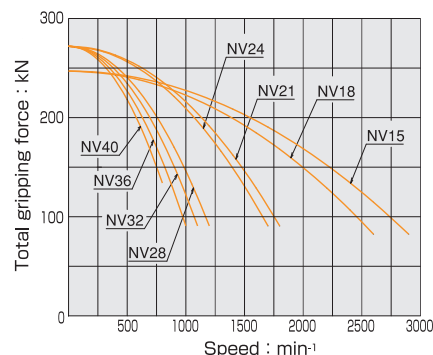

Fig. 2

Gripping Characteristic Graphs

※With standard blank soft top jaw.



Dimensions ※NV15&18 are based on Fig. 1. NV21~40 are based on Fig.2.

Model	A	B	C	D	E	F	G	H	J	K	L	M	N max.	N min.	O max.	O min.	P max.	P min.	Q	R	S	T	U	V	W	X	Y
NV15C15	381	172	380	285.75	62	6	235.0	330.2	-	6-M24	26	43	77.5	69.5	48.75	23.25	91	56	50	25.5	55	M30	5	60	6-M20	64	135
NV18C15	450	172	380	285.75	62	6	235.0	330.2	-	6-M24	26	43	108.0	100.0	48.75	23.25	91	56	50	25.5	55	M30	5	60	6-M20	64	135
NV21C15	530	167	380	285.75	46	6	330.2	330.2	-	6-M24	35	60	86.0	78.0	93.50	27.50	91	56	65	25.0	55	M30	6	60	3-M12	74	180
NV24C15	610	167	380	285.75	46	6	330.2	330.2	-	6-M24	29	60	125.0	117.0	93.50	27.50	91	56	65	25.0	55	M30	6	60	3-M12	74	180
NV28C15	700	167	380	285.75	46	6	330.2	330.2	-	6-M24	29	60	125.0	117.0	141.50	27.50	91	56	65	25.0	55	M30	6	60	3-M12	74	180
NV32C15	800	167	380	285.75	46	6	330.2	330.2	-	6-M24	29	60	125.0	117.0	189.50	27.50	91	56	65	25.0	55	M30	6	60	3-M12	74	180
NV36C15	914	167	380	285.75	46	6	330.2	330.2	-	6-M24	29	60	125.0	117.0	249.50	27.50	91	56	65	25.0	55	M30	6	60	3-M12	74	180
NV40C15	1000	167	380	285.75	46	6	330.2	330.2	-	6-M24	29	60	125.0	117.0	282.50	27.50	91	56	65	25.0	55	M30	6	60	3-M12	74	180

※The above dimensions are for mounting back plate of 15-nose. The back plate of 11-nose can also be mounted.

Specifications

Model	Gripping range mm Max. Min.	Jaw Stroke (diameter) mm	Plunger Stroke mm	Max. Draw bar Pull Force kN (kgf)	Max. Gripping Force kN (kgf)	Max. Speed min ⁻¹	Net Weight with soft top jaws kg	Moment of inertia kg·m ²	Matching Cylinder	Max. pressure MPa (kgf/cm ²)	Matching Soft top jaw	Spindle nose size
NV15C15	381 72	16	35	82 (8362)	247 (25187)	2900	133	2.580	Y2035R	3.2 (32.6)	SB15N1	A ₂ -15
NV18C15	450 133	16	35	82 (8362)	247 (25187)	2600	171	3.300	Y2035R	3.2 (32.6)	SB15N1	A ₂ -15
NV21C15	530 62	16	35	82 (8362)	272 (27736)	1800	210	5.450	Y2035R	3.2 (32.6)	SB18A2	A ₂ -15
NV24C15	610 152	16	35	82 (8362)	272 (27736)	1700	253	7.575	Y2035R	3.2 (32.6)	SB18A2	A ₂ -15
NV28C15	700 152	16	35	82 (8362)	272 (27736)	1200	400	22.000	Y2035R	3.2 (32.6)	SB18A2	A ₂ -15
NV32C15	800 152	16	35	82 (8362)	272 (27736)	1100	445	35.500	Y2035R	3.2 (32.6)	SB18A2	A ₂ -15
NV36C15	914 152	16	35	82 (8362)	272 (27736)	1000	600	62.500	Y2035R	3.2 (32.6)	SB18A2	A ₂ -15
NV40C15	1000 152	16	35	82 (8362)	272 (27736)	800	770	96.500	Y2035R	3.2 (32.6)	SB18A2	A ₂ -15

※The above specifications are for mounting back plate of 15-nose. The back plate of 11-nose can also be mounted.



CHUCK

Closed Centre Power Chuck (Long Stroke) NL series

Extra Long Jaw Stroke Flange work securely gripped

* CE correspondence

Dimensional Drawings

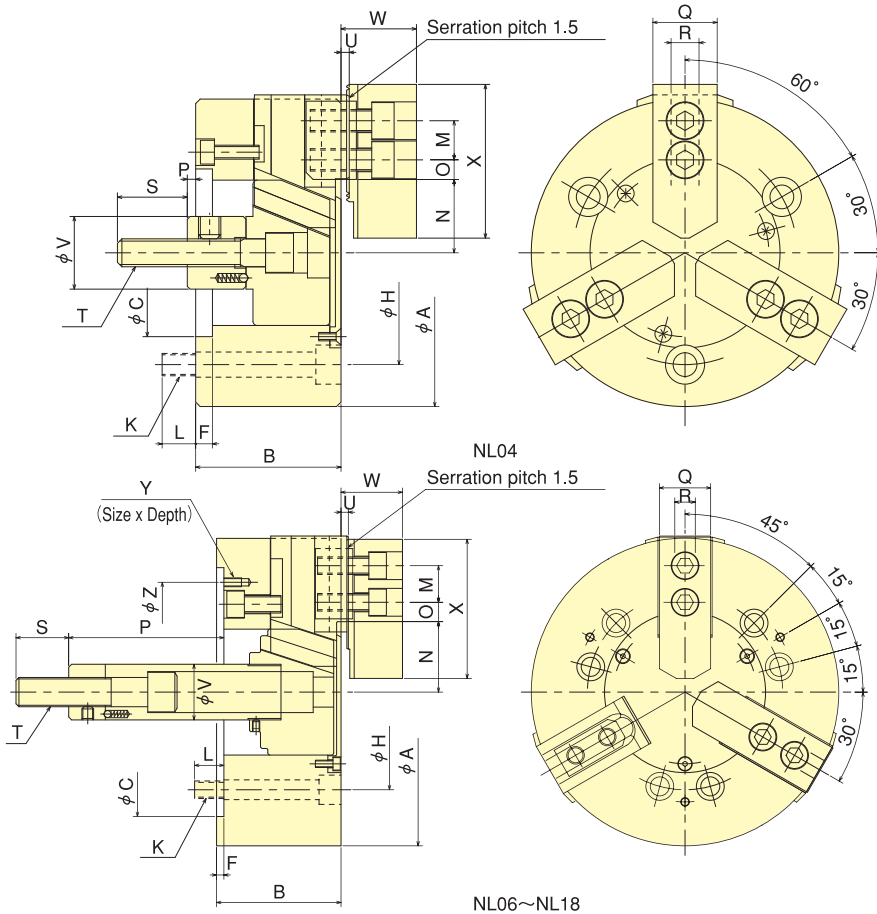

Standard Chuck

Gripping Characteristic Graphs

*With standard blank soft top jaw.

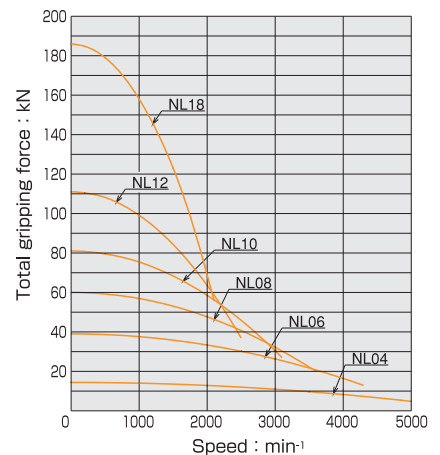

Dimensions

Dimensions Model	A	B	C (H6)	F	H	K	L	M	N max.	N min.	O max.	O min.	P max.	P min.	Q	R	S	T	U	V	W	X	Y	Z
	NL04	110	52	60	6	80	3-M 8	12	14	26.5	20.45	9.75	6.75	18	3	23	10	25	M10×1.5	3	26	27	55	-
NL06	165	74	140	5	104.8	6-M10	14	20	40.5	34	13.75	9.25	101.5	81.5	31	12	36	M16×2.0	4	34	35	72	M6×10	116
NL08	210	85	170	5	133.4	6-M12	20	25	48.1	40	20.75	11.75	131	106	35	14	36	M20×2.5	5	38	42	95	M6×12	150
NL10	254	89	220	5	171.4	6-M16	18	30	54.4	45.35	29.5	11.5	161	133	40	16	36	M20×2.5	5	45	46	110	M8×15	190
NL12	304	106	220	6	171.4	6-M16	18	30	65.7	56	42.75	12.75	47	17	50	18	46	M24×3.0	5	50	54	129	M8×15	190
NL18	450	114	300	6	235	6-M20	30	43	110.5	97.5	47.25	23.25	97	57	50	25.5	55	M30	2	55	61	135	M10×20	260

Specifications

Specifications Model	Gripping range mm		Jaw Stroke (diameter) mm	Plunger Stroke mm	Max. Draw bar Pull Force kN (kgf)	Max. Gripping Force kN (kgf)	Max. Speed min⁻¹	Net Weight with soft top jaws kg	Moment of inertia kg·m²	Matching Cylinder	Max. pressure MPa (kgf/cm²)	Matching Hard top jaw	Matching Soft top jaw
	Max.	Min.											
NL04	110	12	12.1	15	10.0(1020)	14.4 (1468)	5000	4.1	0.008	Y0715R	2.90(29.6)		SB04B1
NL06	165	22	13	20	21.0(2141)	39.0 (3977)	4300	12.0	0.045	Y1020R	3.00(30.6)	HB06B1	SB06B1
NL08	210	23	16.2	25	30.0(3059)	60.0 (6118)	3600	22.9	0.138	Y1225R	2.90(29.6)	HB08A1	SB08B1
NL10	254	27	18.1	28	40.0(4079)	81.0 (8260)	3100	34.6	0.300	Y1530R	2.80(28.6)	HB10A1	SB10A1
NL12	304	33	19.4	30	54.0(5506)	111.0(11319)	2500	60.0	0.725	Y1530R	3.60(36.7)	HB12B1	SB12A1
NL18	450	124	26	40	91.0(9279)	186.0(18966)	2100	124.0	2.350	Y2050R	3.50(35.9)		SB15N1



CHUCK

Closed Centre Power Chuck (Long Stroke, Direct Mount)

NL-A series

Chuck Adaptor is equipped to suit Spindle Nose Flange work securely gripped

*CE correspondence



Standard Chuck

Dimensional Drawings

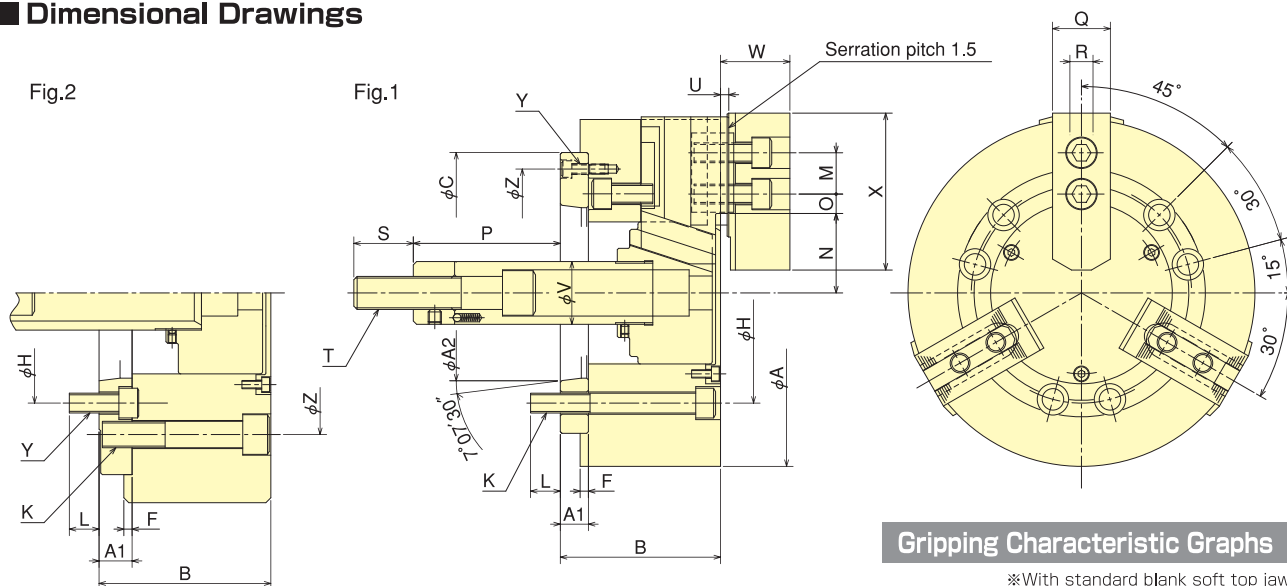

Gripping Characteristic Graphs

*With standard blank soft top jaw.

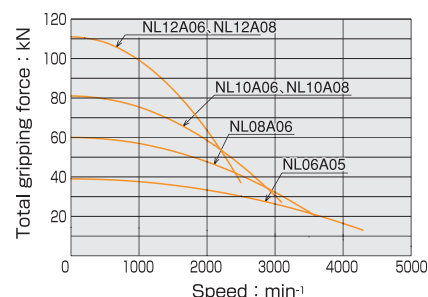

Dimensions *NL10A06 and NL12A06 are based on Fig. 2.

Dimensions Model	A	B	C	F	H	K	L	M	N max.	N min.	O max.	O min.	P max.	P min.	Q	R	S	T	U	V	W	X	Y	Z	A1	A2
NL06A05	165	84	140	5	1048	6-M10	14	20	40.5	34	13.75	9.25	86.5	66.5	31	12	36	M16	4	34	35	72	3-M6	116	15	82.563
NL08A06	210	97	170	5	1334	6-M12	18	25	48.1	40	20.75	11.75	114	89	35	14	36	M20	5	38	42	95	3-M6	150	17	106.375
NL10A06	254	104	220	5	1334	6-M16	18	30	54.4	45.35	29.5	11.5	141	113	40	16	36	M20	5	45	46	110	6-M12	171.4	20	106.375
NL10A08	254	102	220	5	171.4	6-M16	25	30	54.4	45.35	29.5	11.5	143	115	40	16	36	M20	5	45	46	110	3-M8	190	18	139.719
NL12A06	304	120	220	6	1334	6-M16	18	30	65.7	56	42.75	12.75	3	-27	50	18	46	M24	5	50	54	129	6-M12	171.4	20	106.375
NL12A08	304	118	220	6	171.4	6-M16	25	30	65.7	56	42.75	12.75	1	-29	50	18	46	M24	5	50	54	129	3-M8	190	18	139.719

Specifications

Specifications Model	Gripping range mm		Jaw Stroke (diameter) mm	Plunger Stroke mm	Max. Draw bar Pull Force kN (kgf)	Max. Gripping Force kN (kgf)	Max. Speed min⁻¹	Net Weight with soft top jaws kg	Moment of inertia kg·m²	Matching Cylinder	Max. pressure MPa (kg/cm²)	Matching Hard top jaw	Matching Soft top jaw
	Max.	Min.											
NL06A05	165	22	13	20	21.0(2141)	39.0 (3977)	4300	12.5	0.048	Y1020R	3.00(30.6)	HB06B1	SB06B1
NL08A06	210	23	16.2	25	30.0(3059)	60.0 (6118)	3600	24.5	0.148	Y1225R	2.90(29.6)	HB08A1	SB08B1
NL10A06	254	27	18.1	28	40.0(4079)	81.0 (8260)	3100	40.0	0.335	Y1530R	2.80(28.6)	HB10A1	SB10A1
NL10A08	254	27	18.1	28	40.0(4079)	81.0 (8260)	3100	37.6	0.326	Y1530R	2.80(28.6)	HB10A1	SB10A1
NL12A06	304	33	19.4	30	54.0(5506)	111.0(11319)	2500	64.6	0.759	Y1530R	3.60(36.7)	HB12B1	SB12A1
NL12A08	304	33	19.4	30	54.0(5506)	111.0(11319)	2500	63.0	0.750	Y1530R	3.60(36.7)	HB12B1	SB12A1



CHUCK

Mega-Long Stroke Chuck ML series

Exceptionally long Jaw stroke
Suitable for Multi-Diameter gripping and flange work

* CE correspondence



Standard Chuck

Gripping Example

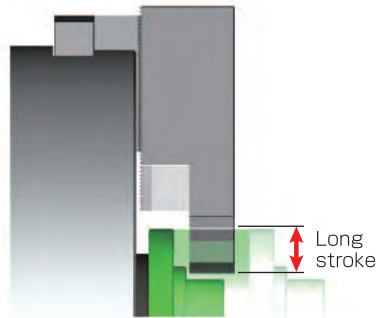

● Suitable for works with large flange

Gripping Characteristic Graphs

*With standard blank soft top jaw.

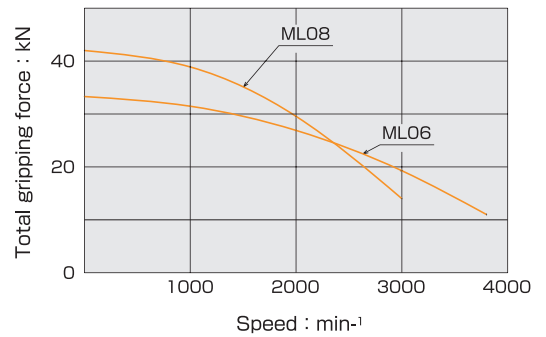

Dimensional Drawings

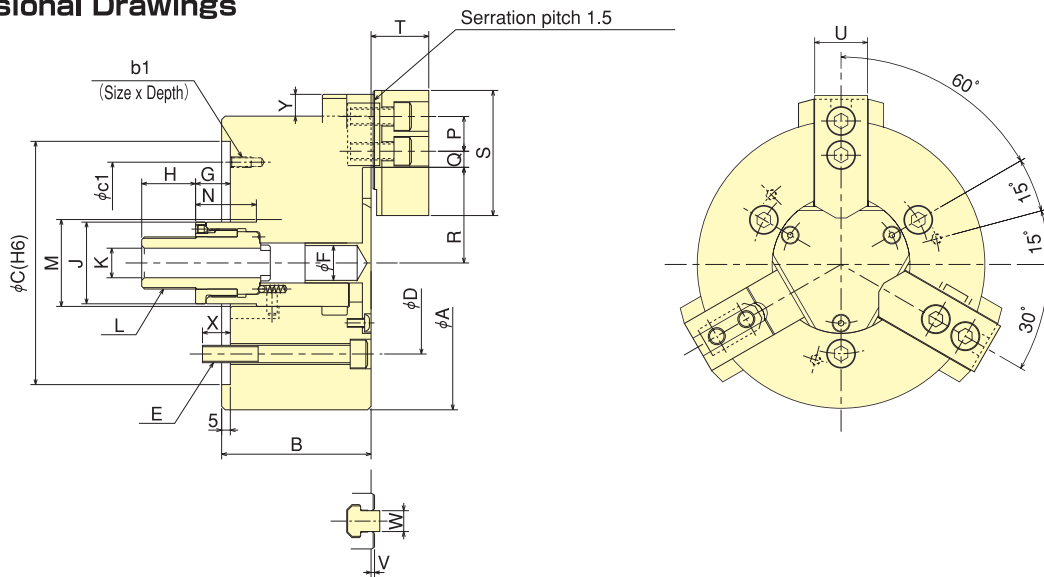

Dimensions

Dimension	A	B	C	D	E	F	G max.	G min.	H	J	K	L	M	N	P	Q max.	Q min.
Model ML06	169	86	140	104.8	3-M10	20	40	20	31	47	17	M30×1.5	50	35	20	13.75	9.25
Model ML08	215	99	170	133.4	3-M12	20	34	9	34	54	17	M33×1.5	70	29	25	17.75	11.75

Dimension	R max.	R min.	S	T	U	V	W	X	Y max.	b1	c1
Model ML06	55	35	72	33.2	31	2	12	16	12.5	3-M6×12	116
Model ML08	65.6	40.6	95	39.2	35	2	14	21	12.1	3-M6×12	150

Specifications

Specification	Gripping diameter mm	Jaw stroke (diameter) mm	Plunger stroke mm	Max. input kN (kgf)	Max. static gripping force kN (kgf)	Max. speed min ⁻¹	Net weight (with standard jaws) kg	Moment of inertia kg·m ²	Matching Cylinder	Max. pressure MPa (kgf/cm ²)	Standard soft jaw
Model ML06	Max. 169 Min. 55	40	20	36.0 (3671)	33.0 (3365)	3800	13.7	0.048	Y1225R	3.46 (35.3)	SB06B1
Model ML08	Max. 215 Min. 54	50	25	45.0 (4589)	42.0 (4283)	3000	26.0	0.167	Y1530R	3.06 (31.2)	SB08B1



CHUCK

2-Jaw Closed Center Power Chuck (NLT-Long Stroke)

NT·NLT series

Best suited for gripping Irregular shaped components

* CE correspondence

Dimensional Drawings

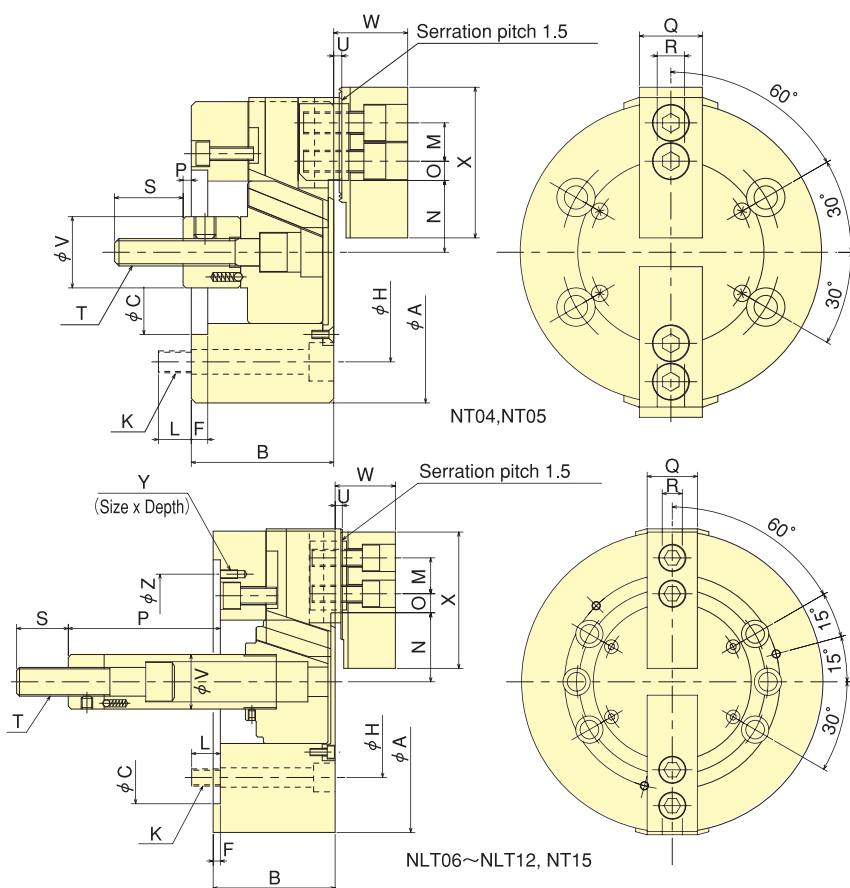

Gripping Characteristic Graphs

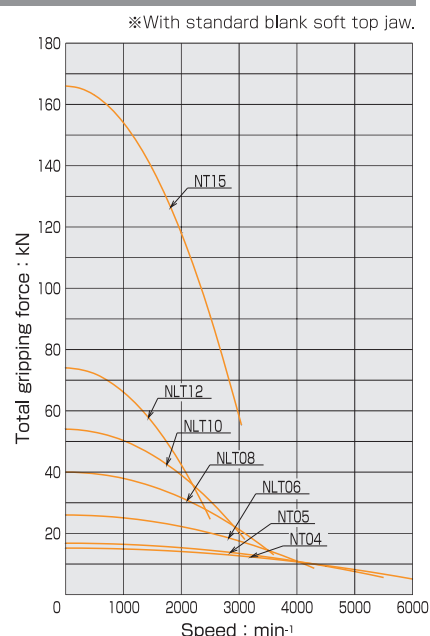

Dimensions

Dimensions Model	A	B	C (H6)	F	H	K	L	M	N max.	N min.	O max.	O min.	P max.	P min.	Q	R	S	T	U	V	W	X	Y	Z
NT04	110	52	60	6	80	4-M8	12	14	23.3	20.1	10.25	8.75	18	3	23	10	25	M10	3	26	27	55	-	-
NT05	135	55	80	7	100	4-M8	14	19	30.4	27.2	11.5	7	9	-6	23	10	35	M12	3	28	29	62	-	-
NLT06	165	74	140	5	104.8	6-M10	14	20	40.5	34	13.75	9.25	101.5	81.5	31	12	36	M16	4	34	35	72	M6×10	116
NLT08	210	85	170	5	133.4	6-M12	20	25	48.1	40	21	12	131	106	35	14	36	M20	5	38	42	95	M6×12	150
NLT10	254	89	220	5	171.4	6-M16	18	30	54.4	45.35	29.5	11.5	161	133	40	16	36	M20	5	45	46	110	M8×15	190
NLT12	304	106	220	6	171.4	6-M16	18	30	65.7	56	42.75	12.75	163	133	50	18	36	M20	5	50	54	129	M8×15	190
NT15	381	114	300	6	235	6-M20	30	43	77.5	69.5	48.75	23.25	104	69	50	25.5	55	M30	2	55	61	135	M10×20	260

Specifications

*Max. speed is shown using actual test data.

Specifications Model	Gripping range mm Max.	Gripping range mm Min.	Jaw Stroke (diameter) mm	Plunger Stroke mm	Max. Draw bar Pull Force kN (kgf)	Max. Gripping Force kN (kgf)	Max. Speed min⁻¹	Net Weight with soft top jaws kg	Moment of inertia kg·m²	Matching Cylinder	Max. pressure MPa (kgf/cm²)	Matching Soft top jaw
NT04	110	5	6.4	15	5.3 (540)	15.2 (1550)	6000	3.8	0.007	Y0715R	1.68 (17.1)	SB04A1T
NT05	135	16	6.4	15	5.3 (540)	16.8 (1713)	5500	5.8	0.013	Y0715R	1.68 (17.1)	SB05A1T
NLT06	165	22	13	20	14.0(1428)	26.0 (2651)	4300	12.5	0.043	Y1020R	2.06 (21.0)	SB06A1T
NLT08	210	24	16.2	25	20.0(2039)	40.0 (4079)	3600	24.0	0.133	Y1225R	2.03 (20.7)	SB08A1T
NLT10	254	27	18.1	28	27.0(2753)	54.0 (5506)	3100	35.5	0.293	Y1530R	1.93 (19.7)	SB10A1T
NLT12	304	33	19.4	30	36.0(3671)	74.0 (7546)	2500	60.5	0.708	Y1530R	2.50 (25.5)	SB12A1T
NT15	381	72	16	35	54.7(5578)	166.0(16927)	3040	93.0	1.790	Y2035R	2.10 (21.4)	SB15N1T

*Altering Back Plate enables to change over 3-Jaw Chuck into 2-Jaw Chuck.



CHUCK

2-Jaw Mega-Long Stroke Chuck MLT series

Exceptionally long Jaw stroke
Best suited for gripping irregular shaped components

*CE correspondence



Standard Chuck

Gripping Example

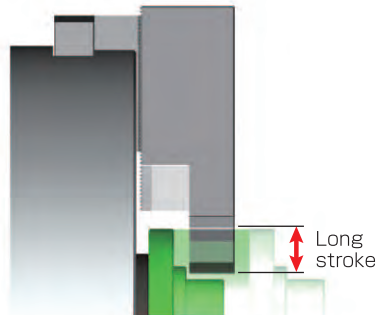

- Suitable for machining of valves.
Common jaw sets can be used due to long stroke.

Gripping Characteristic Graphs

※With standard blank soft top jaw.

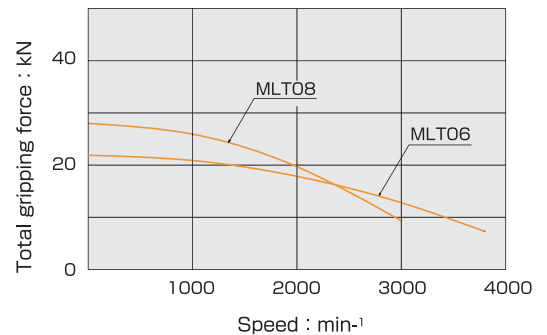

Dimensional Drawings

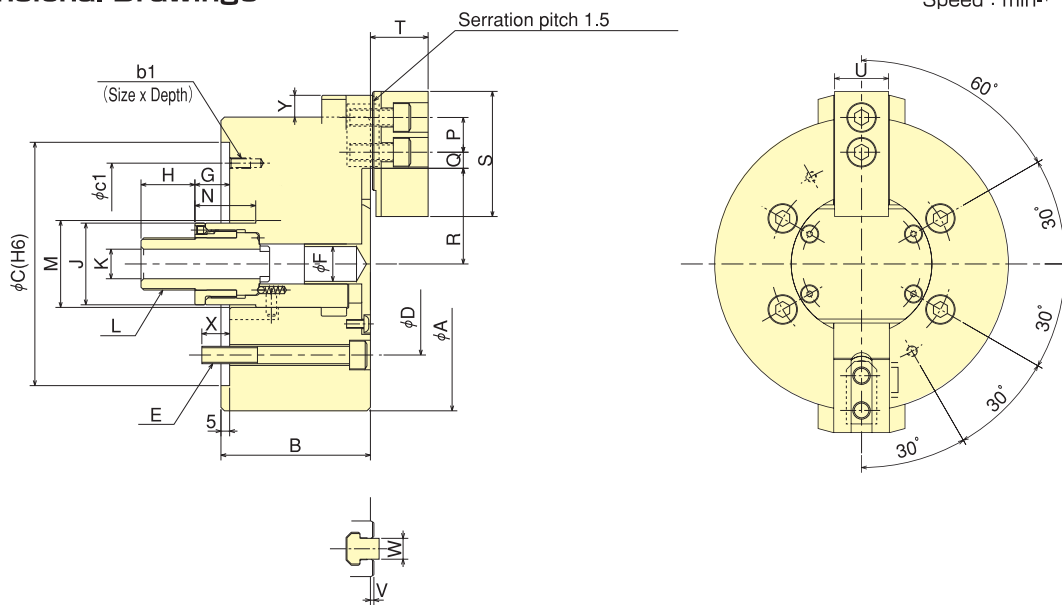

Dimensions

Model	A	B	C	D	E	F	G max.	G min.	H	J	K	L	M	N	P	Q max.	Q min.
MLT06	169	86	140	104.8	4-M10	20	40	20	31	47	17	M30×1.5	50	35	20	13.75	9.25
MLT08	215	99	170	133.4	4-M12	20	34	9	34	54	17	M33×1.5	70	29	25	18	12

Model	R max.	R min.	S	T	U	V	W	X	Y max.	b1	c1
MLT06	55	35	72	33.2	31	2	12	16	12.5	2-M6×12	116
MLT08	65.6	40.6	95	39.2	35	2	14	21	12.1	3-M6×12	150

Specifications

Model	Gripping diameter mm	Jaw stroke (diameter) mm	Plunger stroke mm	Max. input kN (kgf)	Max. static gripping force kN (kgf)	Max. speed min⁻¹	Net weight (with standard jaws) kg	Moment of inertia kg·m²	Matching Cylinder	Max. pressure MPa (kgf/cm²)	Standard soft jaw
MLT06	169	40	40	24.0 (2447)	21.9 (2230)	3800	13.7	0.054	Y1225R	2.39 (24.4)	SB06A1T
MLT08	215	44	50	30.0 (3059)	28.0 (2855)	3000	25.7	0.164	Y1530R	2.13 (21.7)	SB08A1T

※Altering Back Plate enables to change over 3-Jaw Chuck into 2-Jaw Chuck.



CHUCK

1-Jaw Mega-Long Stroke Chuck MLV series

Exceptionally long Jaw stroke
Best suited for jig work fixturing

* CE correspondence



Gripping Example

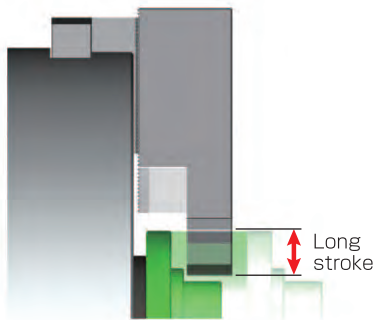

Gripping Example

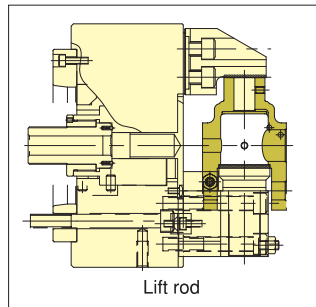

- Halve the set-up time and increase performance.

Gripping Characteristic Graphs

※With standard blank soft top jaw.

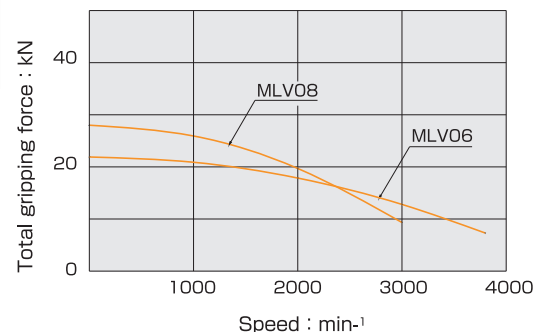

Dimensional Drawings

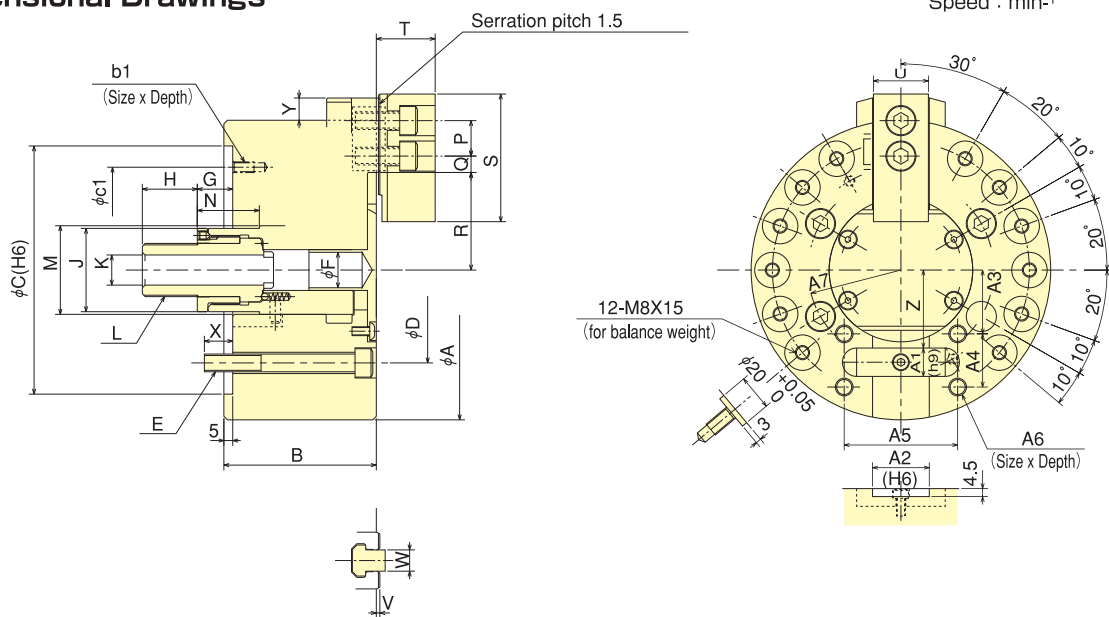

Dimensions

Dimensions	A	B	C	D	E	F	G max.	G min.	H	J	K	L	M	N	P	Q max.	Q min.
Model MLV06	169	86	140	104.8	4-M10	20	40	20	31	47	17	M30×1.5	50	35	20	13.75	9.25
Model MLV08	215	99	170	133.4	4-M12	20	34	9	34	54	17	M33×1.5	70	29	25	18	12

Dimensions	R max.	R min.	S	T	U	V	W	X	Y max.	Z	A1	A2	A3	A4	A5	A6	A7	b1	c1
Model MLV06	55	35	72	33.2	31	2	12	16	12.5	44	16	32	36	30	64	4-M10×16	72.5	2-M6×12	116
Model MLV08	65.6	40.6	95	39.2	35	2	14	21	12.1	60	18	37	51	36	70	4-M12×20	95	3-M6×12	150

Specifications

Model	Max. Gripping diameter mm	Min. Gripping diameter mm	Jaw stroke mm	Plunger stroke mm	Max. input kN (kef)	Max. static gripping force kN (kef)	Max. speed min⁻¹	Net weight (with standard jaws) kg	Moment of inertia kg·m²	Matching Cylinder	Max. pressure MPa (kgf/cm²)	Standard soft jaw
MLV06	169	40	20	20	12.0(1224)	21.9(2230)	3800	13.2	0.050	Y1225R	1.32 (13.5)	SB06A1V
MLV08	215	44	25	25	15.0(1530)	28.0(2855)	3000	25.0	0.155	Y1530R	1.19 (12.3)	SB08A1V



CHUCK

4-Jaw Lever Type Power Operated Chuck with Closed Centre HW series

**Steadily grips block, oval, or any irregular shaped works
Self Centring Mechanism (2+2 Jaws)**

● Self Centring Mechanism

2 independent Jaw sets give Dual Action clamping allowing irregular shapes to be easily gripped. Consequently, it is the best to chuck a deformed work such as a square shape and elliptical shape.

● Long Stroke

Long Jaw Stroke ensures components with variation are gripped securely.

*CE correspondence



Standard Chuck

■ Dimensional Drawings

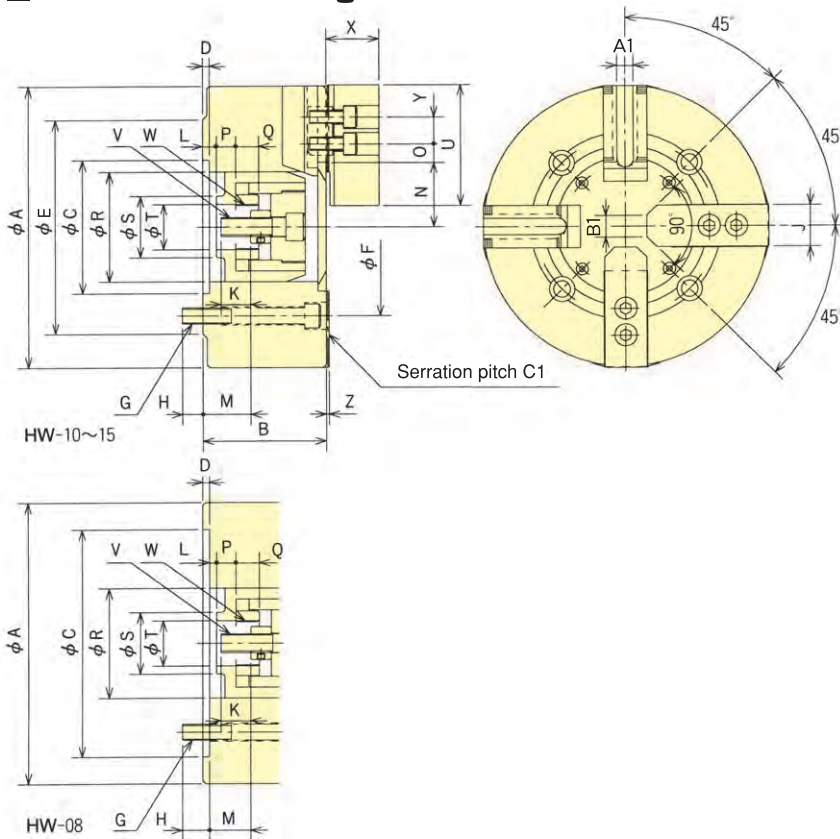

Gripping Example

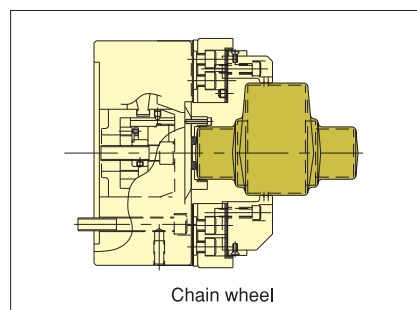

Gripping Characteristic Graphs

*With standard blank soft top jaw.

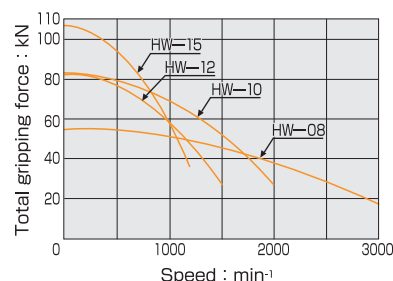

■ Dimensions

Model	Dimensions																V	W	X	Y	Z	A1	B1	C1								
	A	B	C (H6)	D	E	F	G	H	J	K	L max.	L min.	M max.	M min.	N max.	N min.									O max.	O min.	P	Q	R	S	T	U
HW-08	210	91	170	5	-	133.4	4-M12	20	31	29	10.5	-6.5	39	22	50.3	43.7	28.75	9.25	17.5	17	82	46	34	90	M14x2.0	M34x1.5	39	20	2	12	16	1.5
HW-10	270	110	120	5.5	200	170	4-M16	24	40	31	18	-4	49	27	64	56	28	13	20	20	103	58	42	110	M16x2.0	M42x1.5	45	30	5	16	-	3.0
HW-12	304	110	120	5.5	200	170	4-M16	24	40	31	18	-4	49	27	64	56	49	13	20	20	103	58	42	110	M16x2.0	M42x1.5	45	30	5	16	-	3.0
HW-15	381	135	195	7.5	285	235	4-M20	30	50	55	26	1	59.5	34.5	78	69.5	66.5	12.5	18.5	24	130	78	55	129	M20x2.5	M55x2.0	53	38	5	18	-	3.0

■ Specifications

Model	Gripping range mm		Jaw Stroke (diameter) mm	Plunger Stroke mm	Max. Draw bar* (Per of Plunger) kN (kgf)	Max. Gripping Force* (Per of Jaw) kN (kgf)	Max. Speed min⁻¹	Net Weight with soft top jaws kg	Moment of inertia kg·m²	Matching Cylinder	Max. pressure MPa(kgf/cm²)	Matching Soft top jaw
	Max.	Min.										
HW-08	210	26	13.2	17	16.5 (1683)	28.0 (2855)	3000	23.0	0.153	YW1220R	1.71 (17.4)	SB08B1Q
HW-10	270	54	16	22	23.0 (2345)	42.0 (4283)	2000	50.0	0.500	YW1225R	2.29 (23.4)	SB10A2Q
HW-12	304	54	16	22	23.0 (2345)	42.0 (4283)	1500	58.0	0.700	YW1225R	2.29 (23.4)	SB10A2Q
HW-15	381	63	17	25	28.0 (2855)	54.0 (5506)	1200	118.0	2.250	YW1225R	2.73 (27.8)	SB15A2Q

*In chuck total, both maximum allowable input value and static gripping force value are double on the above list.

*The movement order of jaw cannot be assigned in combination with YW cylinder. (Contact to Kitagawa when assignment is required.)



CHUCK

3-Jaw Air-Operated Self Contained Chuck UVE..K series

Built-in Pneumatic Cylinder

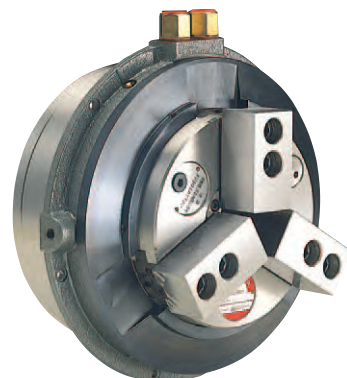

Dimensional Drawings

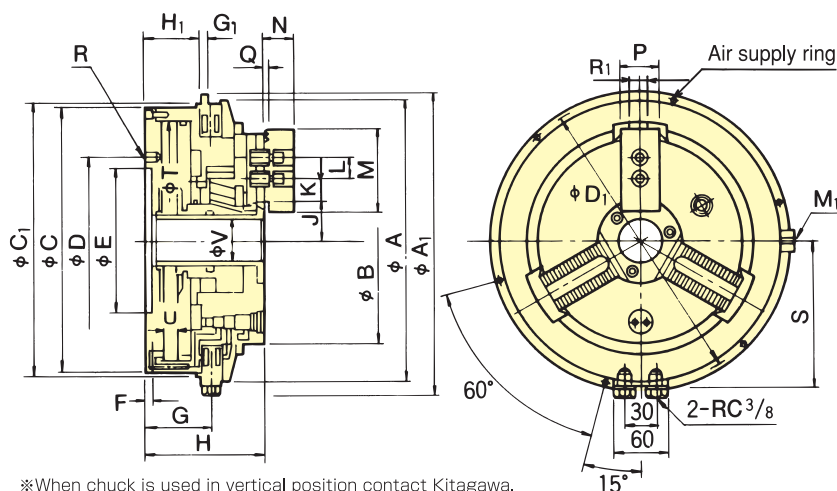

※When chuck is used in vertical position contact Kitagawa.

Gripping Characteristic Graphs

※Each curve shows air pressure 0.6MPa (6.1kgf/cm²). This is a case that standard soft jaws are used.

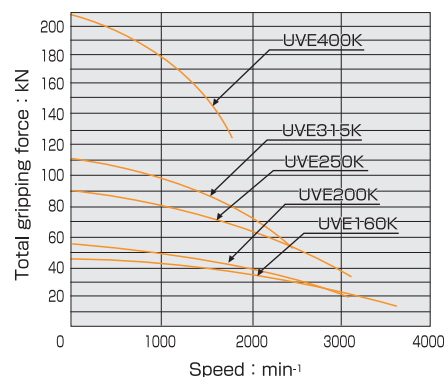

Dimensions

Mode	A	B	C	D	E (H7)	F	G	H	J max.	J min.	K max.	K min.	L	M	N	P	Q	R	S	T	U	V	A ₁	C ₁ (h6)	D ₁	G ₁	H ₁ ±0.1	M ₁	R ₁
UVE160K	250	170	230	180	160	6.5	83	137	33.5	29.3	19.25	10.25	25	76.5	38.5	40	2.25	6-M10	138	205	24	38	273	240	260	6	71	M10	14
UVE200K	280	200	260	210	185	8	82.5	141	43	38.8	20.25	11.25	30	110	43	40	2.25	6-M10	150	230	24	50	302	275	288	6	69	M10	16
UVE250K	330	250	310	260	235	8	87.5	151	47.5	42.6	39.75	12.75	30	110	43	40	2.25	6-M10	175	280	28	60	350	320	336	6	74	M12	16
UVE315K	385	315	365	315	290	8	90.5	155	64	59.1	46.25	14.75	38	129	51	50	2.25	6-M10	206	335	28	92	410	380	395	8	77	M12	18
UVE400K	495	400	475	340	300	8	118	200	86	79	37.5	16.5	60	156	71	62	3.3	6-M16	257	440	40	120	518	485	505	8	104	M16	22

Specifications

Mode	Centre hole dia mm	Gripping range mm (Max. Min)	Jaw Stroke (diameter) mm	Plunger Stroke mm	Max. Gripping Force (at air pressure 0.6MPa (6.1kgf/cm ²)) kN (kgf)	Max. Speed min ⁻¹	Net Weight kg	Moment of inertia kg·m ²	Matching Soft top jaw	Air consumption per 10mm (at air pressure 6.1kgf/cm ²) l	Serration pitch
UVE160K	38	170 18	8.4	24	45.0 (4588)	3600 (3500)	29.5	0.250	SB06C1	2.375	1.5
UVE200K	50	200 18	8.4	24	54.0 (5506)	3200 (2800)	38.5	0.350	SB10B1	2.990	1.5
UVE250K	60	250 18	9.8	28	90.0 (9177)	3000 (2200)	61.0	0.725	SB10B1	4.432	1.5
UVE315K	92	315 48	9.8	28	111.0 (11318)	2500 (1800)	81.0	1.450	SB12C1	6.343	1.5
UVE400K	120	400 90	14	40	210.0 (21413)	1800 (1200)	145.0	4.375	SB15A2	10.943	3

※Maximum speed is shown with each value under air pressure of 0.6MPa, using standard soft jaw and fixed air supply ring. If the supply ring is not fixed, each value in () is applied.

※Gripping force of a jaw is one third of max. gripping force.

※Standard accessories : Soft jaw, air pressure gauge, tools of a set.

Hard Jaw (Option accessories)

Model	Chucking range	Hard jaw
UVE160K	φ12~φ170	HBO6U1
UVE200K	φ14~φ180	HBO8U1
UVE250K	φ21~φ225	HBO8U1
UVE315K	φ36~φ310	HB12U1
UVE400K	φ80~φ400	HB16U2

※Hard jaw for UVE200K & 250K is same.

※Hard jaw for UVE500K size or more is manufactured under prearrangement.

Recommended air circuit diagram

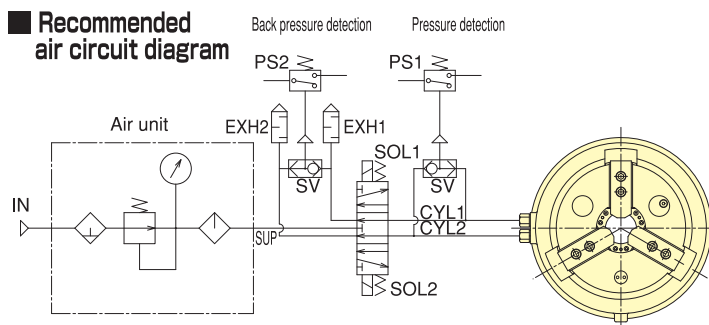



CHUCK

3-Jaw Air-Operated Self Contained Chuck UB series

Built-in Pneumatic Cylinder Large chuck best suited for pipe processing

- The jaw position can be detected
 - Internal pressure can be detected
- * CE correspondence



Standard Chuck

Dimensional Drawings

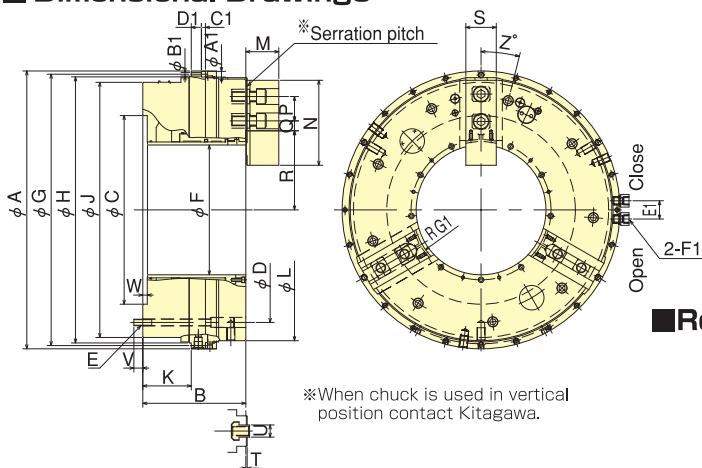

Dimensions

Model	A1	B1	C1	D1	E1	F1	G1
UB450K/P	11	6.6	6.6	25	45	RC 3/8	87.5
UB560K/P	14	9	9	20	45	RC 1/2	134
UB630K/P	14	9	10	25	45	RC 1/2	160
UB710K/P	17	11	11	33	45	RC 1/2	185

Recommended Air Circuit Diagram

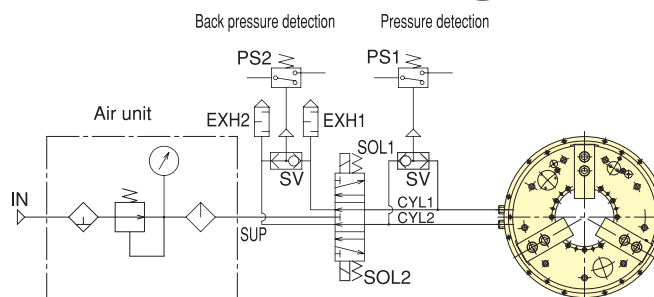

*Serration pitch Model UBxxxK : mm, UBxxxP : inch

Model	A		B		C (H7)		D	E	F	G	M		N	P	Q max.	Q min.	R max.	R min.	S	T	U	V	W	Z	
	mm	inch	mm	inch	mm	inch																			
UB450K/P	494	212	275	373	9-M12	181	481	470	431	98.5	441	67.3	68.7	165	43	41.5	17.5	121.4	114.4	62	3.3	25.5	17	6	20
UB560K/P	626	230	375	485	6-M16	275	610	595	556	113.5	568	70.5	71.9	180	60	42	18	169	160.5	65	3.3	25.5	24	11	40
UB630K/P	698	254	465	555	9-M16	320	682	669	629	119.5	645	81.3	82.7	209.5	60	50.5	23.5	195	186.5	75	3.3	30	22	11	14
UB710K/P	790	252	520	620	9-M16	375	770	745	702	118.5	714	81.3	82.7	209.5	60	62.3	26.3	222.5	211.5	75	3.3	30	24	11	24

Specifications

Model	Specifications	Centre hole dia mm		Gripping range mm		Jaw Stroke (diameter) mm	Plunger Stroke mm	Max. Gripping Force at air pressure kN (kgf)	Max. Speed min ⁻¹	Weight (with std. jaw) kg	Moment of inertia kg·m ²	Max pressure MPa (kgf/cm ²)	Air consumption per 10mm (at air pressure 0.6MPa (6.1kgf/cm ²))
		Max.	Min.	Max.	Min.								
UB450K/P		181	441	120	14	40	100.0 (10200)	1300	204.0	5.550	0.6 (6.1)	4.83	
UB560K/P		275	568	220	17	37	120.0 (12230)	1100	320.0	15.800	0.6 (6.1)	7.17	
UB630K/P		320	645	225	17	37	162.0 (16520)	1000	480.0	28.100	0.6 (6.1)	9.27	
UB710K/P		375	714	275	22	36	144.0 (14680)	900	550.0	38.900	0.6 (6.1)	11.10	

*Maximum speed is shown with each value under air pressure of 0.6MPa, using standard soft jaw and fixed air supply ring. If the supply ring is not fixed, each value in () is applied.

*Gripping force of a jaw is one third of max. gripping force. *Standard accessories : Soft jaw, air pressure gauge, tools of a set.

*The work of diameter smaller than the above minimum gripping diameter can be gripped by using a collet pad (option).

AVF-3-FL type manual change valve (Special accessories)

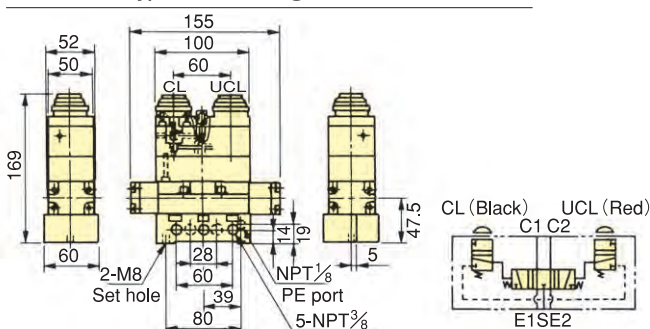

This valve is light-weight, compact and can be operated with the press of a button. The simple piping can be routed when the selector is mounted on the lathe. The valve is the exhaust centre type and designed for exclusive UB types.

Pressure	0~1MPa (10.1kgf/cm ²)
Proof pressure	1.5MPa (15.3kgf/cm ²)
Push button operation force	4kg
Connection bore	RC ³ / ₈



CHUCK

3-Jaw Air-Operated Self Contained Chuck (Long Stroke)

UBR series

Dual Speed Jaw Stroke Large chuck best suited for pipe processing



- Built-in Pneumatic Cylinder
- 2-stage stroke
Initially, jaws move quickly, slowing just before gripping thus reducing overall gripping time.
- Optimum for Jaw position confirmation
- Internal pressure can be detected

*CE correspondence

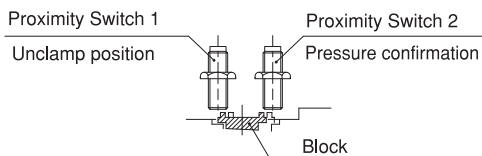

1. Unclamp position confirmation by proximity switch 1.
2. Clamp position confirmation by proximity switch 2.

Dimensional Drawings

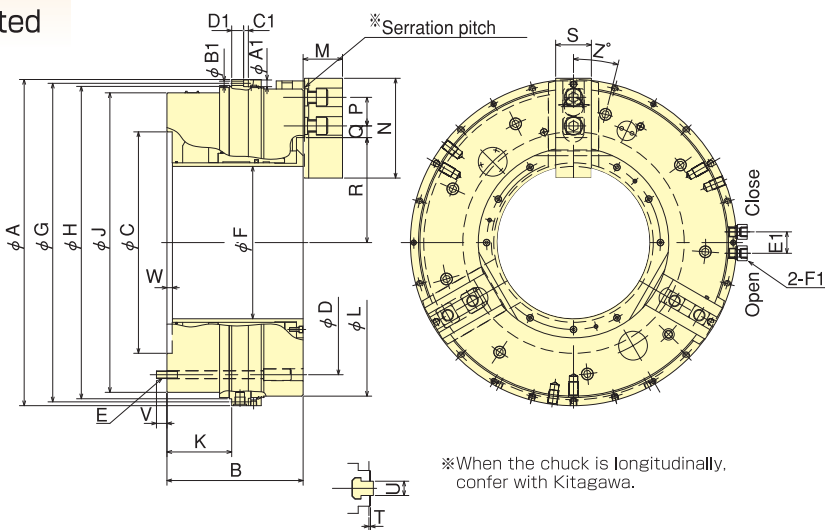

Recommended air circuit diagram

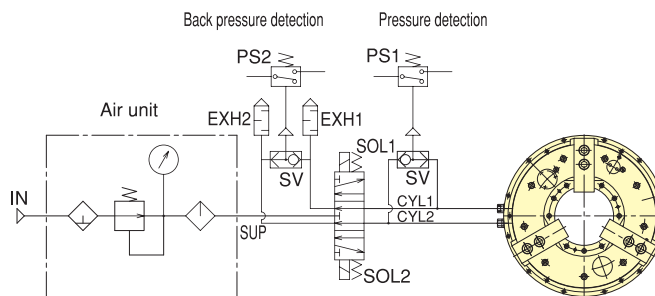

Dimensions

Model	A1	B1	C1	D1	E1	F1
UBR450K/P	11	6.6	6.6	25	45	RC 3/8
UBR560K/P	14	9	9	20	45	RC 1/2
UBR630K/P	14	9	10	25	45	RC 1/2
UBR710K/P	17	11	11	33	45	RC 1/2

Model	A	B	C (H7)	D	E	F	G	H (H7)	J	K	L	M		N	P	Q max.	Q min.	R max.	R min.	S	T	U	V	W	Z
												mm	inch												
UBR450K/P	494	232	275	373	9-M12	181	481	470	431	111.5	441	67.3	68.7	165	43	37.1	16.1	140.5	120.5	62	3.3	25.5	17	6	20
UBR560K/P	626	275	375	485	6-M16	275	610	595	556	130	568	70.5	71.9	180	60	32.5	20.5	196.5	171.5	65	3.3	25.5	24	11	40
UBR630K/P	698	286	465	555	9-M16	320	682	669	629	136	645	81.3	82.7	209.5	60	38.5	20.5	220.5	195.5	75	3.3	30	22	11	14
UBR710K/P	790	286	520	620	9-M16	375	770	745	702	136	714	81.3	82.7	209.5	60	50.5	23.5	248	223	75	3.3	30	24	11	24

*The specification of serration pitch can be selected. Type UBRXXXK: millimeter, Type UBRXXXP: inch

Specifications

Model	Centre hole dia mm	Gripping range mm		Jaw Stroke Rapid/Gripping (diameter) mm	Plunger Stroke mm	Max. Gripping Force at air pressure kN (kgf)	Max. Speed min ⁻¹	Weight (with std. jaw) kg	Moment of inertia kg·m ²	Max pressure MPa (kgf/cm ²)	Air consumption per 10mm (at air pressure 0.6MPa (6.1kgf/cm ²)) l
		Max.	Min.								
UBR450K/P	181	441	127	26 / 14	53	100.0 (10200)	1300	216.0	5.480	0.6 (6.1)	4.83
UBR560K/P	275	568	235	33 / 17	53.5	120.0 (12230)	1100	380.0	17.500	0.6 (6.1)	7.17
UBR630K/P	320	645	235	33 / 17	53.5	147.0 (15000)	1000	520.0	30.600	0.6 (6.1)	9.27
UBR710K/P	375	714	290	33 / 17	53.5	162.0 (16520)	900	595.0	42.600	0.6 (6.1)	11.10

*Maximum speed is shown with each value under air pressure of 0.6MPa, using standard soft jaw and fixed air supply ring. If the supply ring is not fixed, each value in () is applied.

*Gripping force of a jaw is one third of max. gripping force. *Standard accessories : Soft jaw, air pressure gauge, tools of a set.



CHUCK

3-Jaw Ultra High Precision Air Chuck KPC series

High Repeatability

Optimum KPC chuck for finishing and precision processes



● Built-in Pneumatic Cylinder

Dimensional Drawings

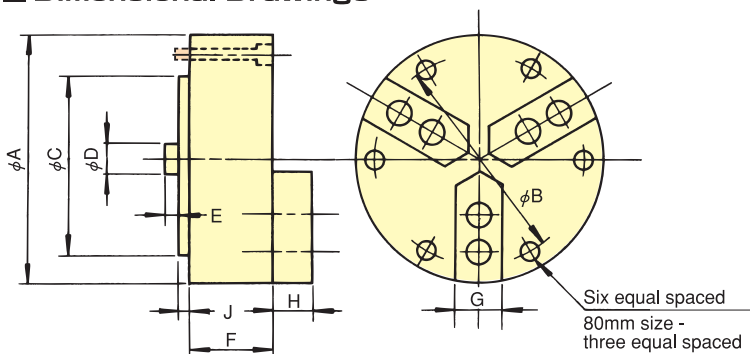

Gripping Characteristic Graphs

※ Each curve shows air pressure 0.7MPa (7.1kgf/cm²). This is a case that standard soft jaws are used.

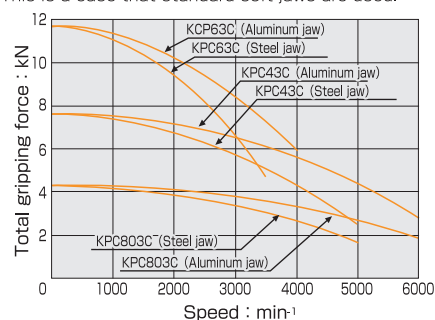

Dimensions

Dimensions model	A	B	C (h6)	D	E max.	E min.	F	G	H	J	Jaw Mounting bolts	Mounting bolts	Weight (with soft top jaw) kg
KPC803C100	80	70	60	20.6	17	9.9	55	20	19	2	3×1-M5×16	3-M5×60	1.8
KPC43C048	100	88.9	82.55	20.6	18.8	15.3	50.5	20	19	2	3×2-M5×16	6-M5×55	2.1
KPC43C100	100	88.9	82.55	20.6	18	10.8	55	20	19	2	3×2-M5×16	6-M5×60	2.1
KPC63C100	150	135.8	124.97	20.6	17.6	10.4	56	25	19	2	3×4-M5×16	6-M6×65	6.3

Specifications

model	Specifications	Repeatability mm	Number of Jaws	Jaw stroke (diameter) mm	Range		Max. Gripping Force kN (kgf) (Air pressure 0.7MPa)	Max. speed (with std. Aluminum jaw) min ⁻¹
					Outer gripping mm	Inner gripping mm		
KPC803C100P		0.0025	3	2.5	3~70	6~79	4.3 (438)	6000
KPC803C100EP		0.0013						
KPC803C100EP1		0.0010						
KPC43C048P		0.0025	3	1.2	3.5~87	6~99	7.6 (775)	6000
KPC43C048EP		0.0013						
KPC43C048EP1		0.0010						
KPC43C100P		0.0025	3	2.5	3~87	6~99	7.6 (775)	6000
KPC43C100EP		0.0013						
KPC43C100EP1		0.0010						
KPC63C100P		0.0025	3	2.5	3~135	6~149	11.6 (1183)	4000
KPC63C100EP		0.0013						
KPC63C100EP1		0.0010						

Ordering length of air feed tube (option)

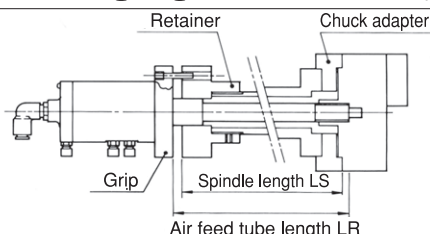

When ordering the air feed tube (coolant or non-coolant type), specify the spindle length LS as shown in the illustration. Air feed tube length LR is determined by LS. E.G. LR = LS + 17

In case of KPC43C048: LR = LS + 12
Chuck Adaptor and Retainer are options

Standard type jaw

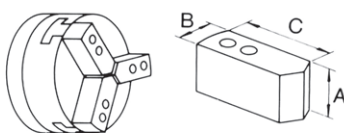

Pie type jaw

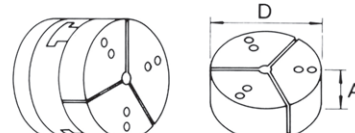

Standard type jaw Dimensions

Chuck	Jaw model	Mat-erial	Dimensions mm		
			A	B	C
KPC80 TYPE	KJ1A3-7	A l	19	20	38.4
	KJ1A3-15	A l	38	20	38.4
	KJ1A3-1	A l	25	20	38.4
	KJ1S3-7	S45C	19	20	38.4
	KJ1S3-15	S45C	38	20	38.4
KPC4 TYPE	KJ1A4-1	A l	25	20	48.4
	KJ1A4-7	A l	19	20	48.4
	KJ1A4-15	A l	38	20	48.4
	KJ1S4-1	S45C	25	20	48.4
	KJ1S4-2	S45C	51	20	48.4
KPC6 TYPE	KJ1S6-7	S45C	19	25	73.4
	KJ1S6-15	S45C	38	25	73.4
	KJ1S6-1	S45C	25	25	73.4

Pie type jaw Dimensions

Chuck	Jaw model	Mat-erial	Dimensions mm	
			A	D
KPC80 TYPE	KJ3A3-1	A l	25	80
	KJ3S3-1	S45C	25	80
	KJ3S3-7	S45C	19	80
KPC4 TYPE	KJ3A4-1	A l	25	100
	KJ3A4-15	A l	38	100
	KJ3S4-2	S45C	51	100
	KJ3S4-7	S45C	19	100
	KJ3S4-15	S45C	38	100
KPC6 TYPE	KJ3S6-1	A l	25	150
	KJ3S6-7	S45C	25	150
	KJ3S6-15	S45C	38	150



CHUCK

▶ **P.39~P.52**

Advanced Chuck

Advanced Chuck

**Exclusively designed work
specific chucks for mass
production**

Designed with gripping to accommodate a variety of applications.



CHUCK

Dual Lock Chuck DL200 series

2-Way gripping

Unbelievable versatility with the ability to grip anything you want



● Increased gripping options

KITAGAWA introduce the worlds 1st chuck with two stage gripping action.

Parallel jaw clamping with secondary pull back action for work seating.

Jaws do not protrude in the Z Axis unlike conventional pull back chucks. This allows for improved gripping on difficult areas.

The gripping range is extended up the chuck OD allowing a wider range of workpieces to be machined.

DL series contributes to improve the productivity by applying flexible chucking for various operations.

● Ideal for volume production machining

Dust proof sealed body design for long life. Suitable for automation and volume production.

● Easy jaw forming

Serrated Jaws are used allowing for easy jaw forming by customer.

*CE correspondence

Gripping Example

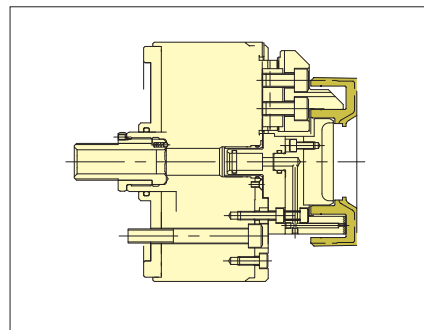

Example

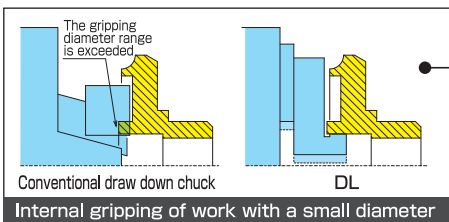
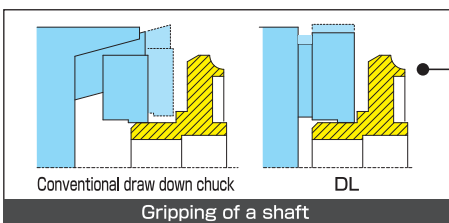
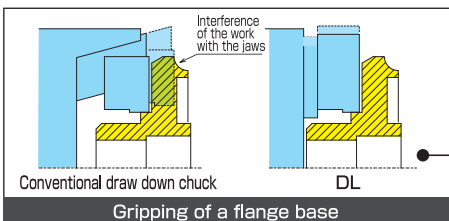

Possible gripping position
■ DL chuck
■ Conventional draw down chuck

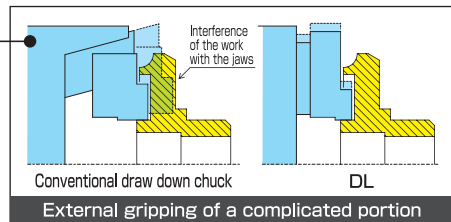
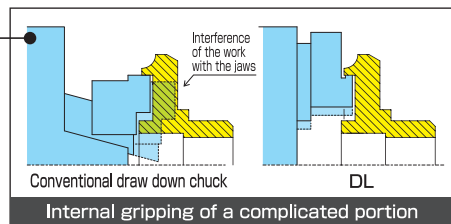
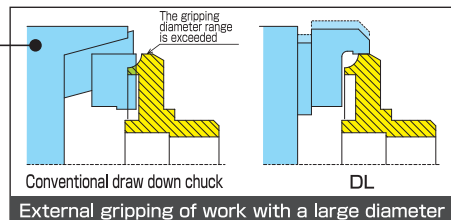

Precautions for operation

1. Attach a work to a locator before gripping.
2. Do not use the chuck with a T-nut protruded from a master jaw end face.
3. When changing the method for gripping an inner diameter of the work from an outer diameter of the work, remove a cover in order to rotate the master jaw 180-degree.
4. A work pulling quantity varies by gripping conditions such as the gripping diameter of the work, stiffness of each jaw, jaw gripping height, etc. If the work will be deformed due to over-pulling of the work or vice versa, it is necessary to adjust parts or replace them. In this case, confer with our company.

5. To obtain a stable gripping and adequate pulling of the work, set jaws low.
6. For additional machining to the chuck end face, a pin hole level is acceptable. Take care so as not to pass through the cover.
7. For locator mounting tap of DL206, use a cover mounting tap.
8. When using optional jaws for DL206 and DL210, the additional machining of jaws may be required.
9. Optional jaw of DL210 is SB12A1 of 12-inch. Take care so as not to use a wrong type of the jaw.
10. Refer to the amounts below for Jaw Stroke (one side) from the gripping position to the unclamping position.
DL206 : 0.7mm, DL208 : 0.8mm, DL210 : 1mm, DL212 : 1mm
11. Confer with our company about other unclear points.

Advanced Chuck

Dimensional Drawings

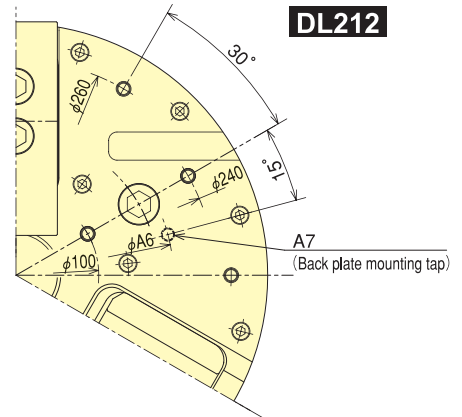
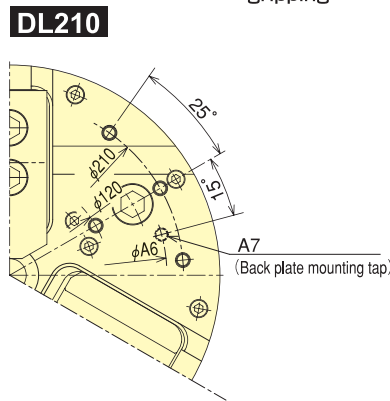
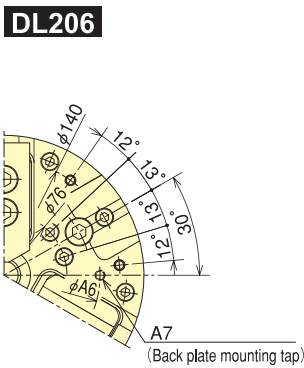
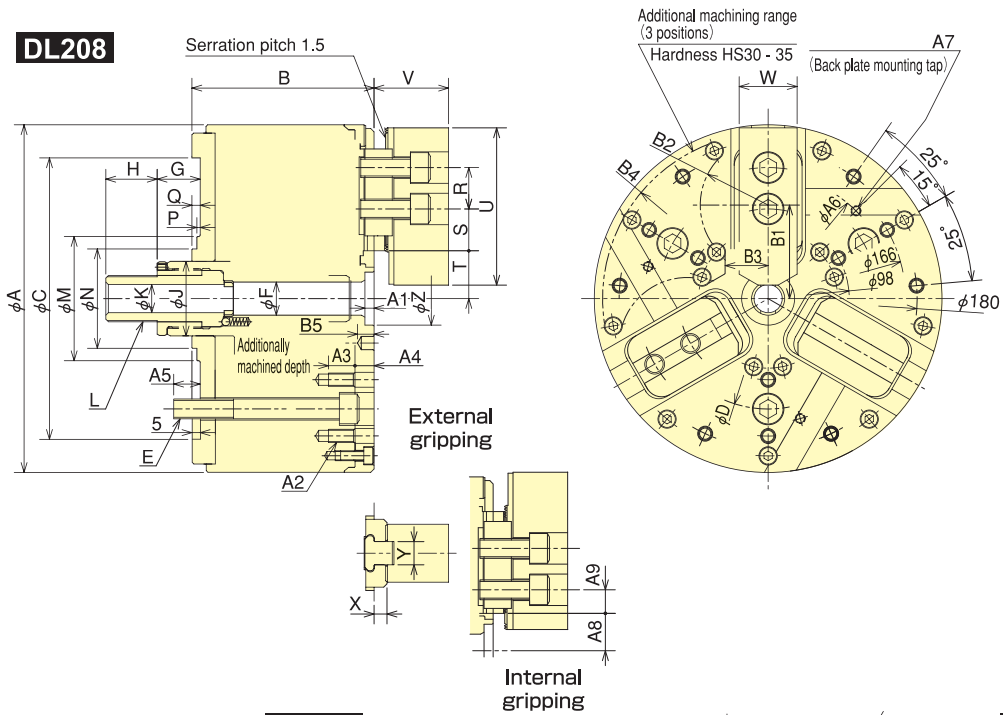



CHUCK

Power Wing Chuck PW(C) series

※PWC has the same specification as PW with the exception of the fact that PWC is a compensation type.

Pull back of workpiece for secure gripping of casting or forging PWC compensating type for rough casting through centre



●Powerful Gripping

After gripping the component in a radial direction, a power PULL-BACK action is applied which significantly increases the Gripping Force, allowing a heavier machine cut to be taken.

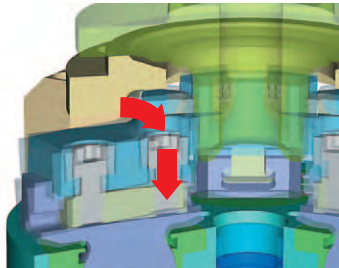

●High Durability

Master jaws are of spherical design and sealed against swarf and coolant. This permits High Gripping Forces to be retained between lubrication periods.

●Complete Sealing

Additional sealing at (1) and (2) reduces grease contamination and increases maintenance period.

●JAW Equalising 5°max equalising angle

Various workpieces can be firmly gripped by the self-equalising jaws to max. 5°.

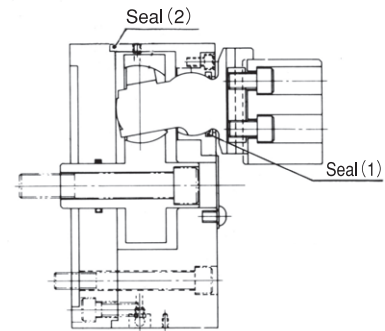
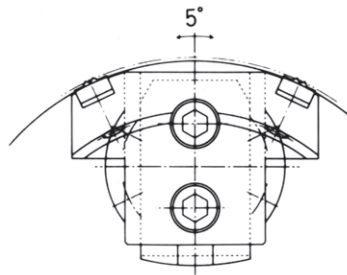

●Gripping on Tapered Parts

The radial and PULL-BACK jaw action allows rough tapered castings and forgings to be securely gripped to maximum 20°.

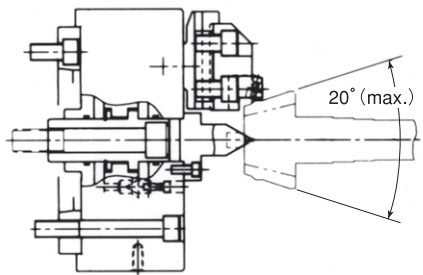

■Type of the gripping pieces

*The type of the gripping pieces is selected according to the work conditions.

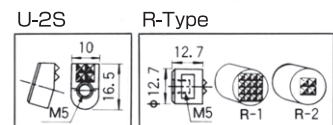
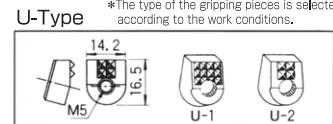

*CE correspondence

Work Examples

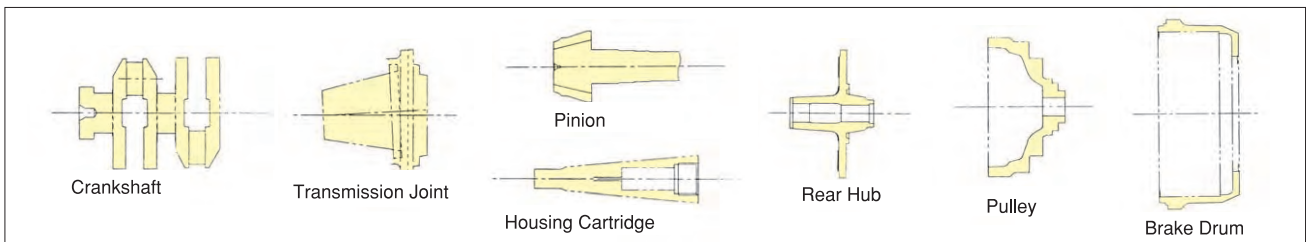

Gripping Examples

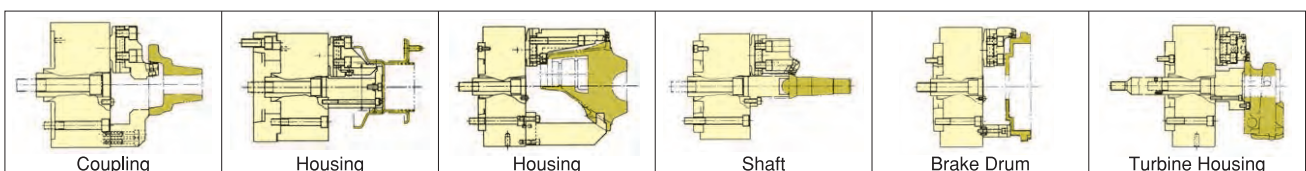

Advanced Chuck

Dimensional Drawings

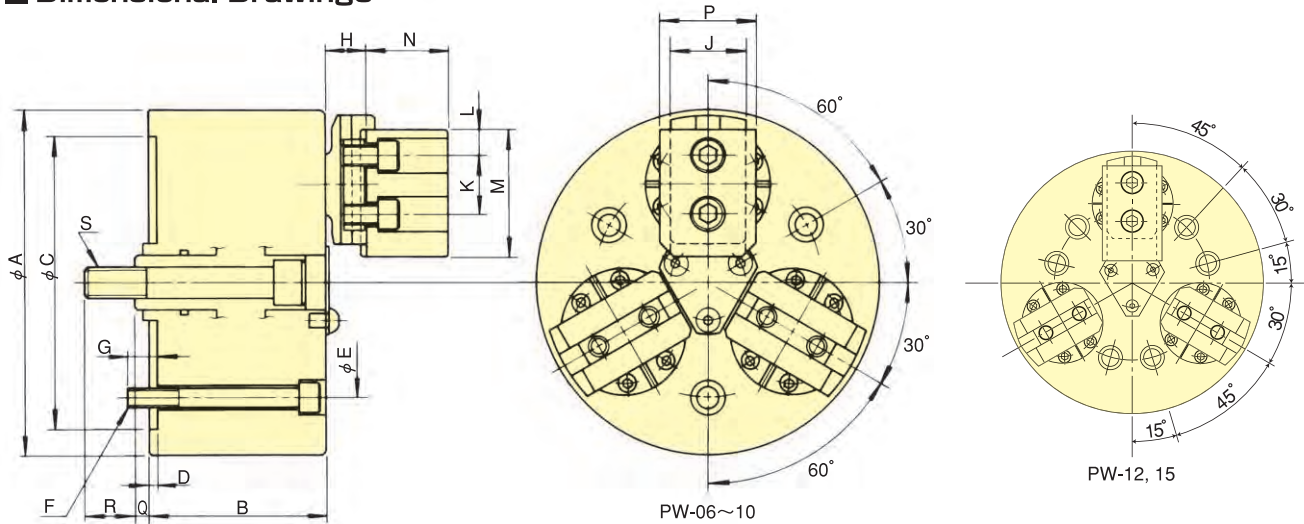

Dimensions

Model	A	B	C(H6)	D	E	F	G	H	J
PW-06	162	77	140	5	104.8	3-M10	14	19.3	38.07
PW-08	200	88	170	5	133.4	3-M12	18	23.33	44.45
PW-10	254	105	220	5	171.4	3-M16	25	29.14	57.1
PW-12	300	105	220	5	171.4	6-M16	25	29.14	57.1
PW-15	381	117	300	5	235	6-M20	30	32.4	66.62

Model	K	L	M	N	P	Q max.	Q min.	R	S
PW-06	29.36	15	67.5	47.7	50.8	24	12.6	25.4	M16
PW-08	34.14	15	74	54.17	57	29.3	15.1	29.2	M18
PW-10	44.45	19	89.5	66.9	70.1	34.9	17.4	34.7	M22
PW-12	44.45	19	108.5	66.9	70.1	34.9	17.4	34.7	M22
PW-15	53.98	23.9	140	73.2	76.2	48.7	26.3	41	M27

Gripping Performance

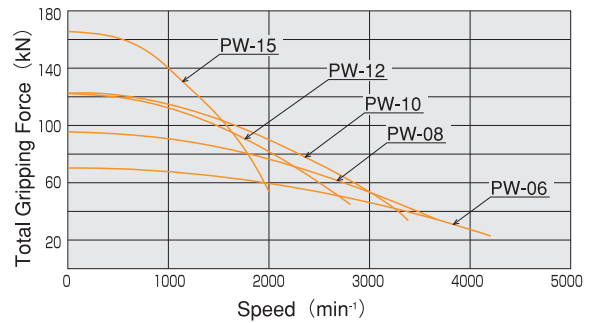

Specifications

Model	Jaw stroke (diameter)mm	Plunger stroke mm	Max. pull force kN(kgf)	Max. gripping force kN(kgf)	Max speed min ⁻¹	Mass (with Standard Soft Jaw) kg	Moment of inertia kg · m ²	Matching cylinder	Max. pressure MPa(kgf·cm ²)	Gripping range		Compensation value for P110 only mm
										external φ mm	internal φ mm	
PW-06	7.9	11.4	23.3(2376)	70.0(7138)	4200	14.7	0.050	Y1225R	2.30(23.5)	12.7~120	70~152	1.0
PW-08	9.5	14.2	32.0(3263)	96.0(9788)	3700	23.5	0.110	Y1225R	3.09(31.5)	16~152	76~203	1.5
PW-10	12.7	17.5	41.0(4180)	123.0(12540)	3400	39.3	0.265	Y1530R	2.80(28.5)	50~203	85~235	2.0
PW-12	12.7	17.5	41.0(4180)	123.0(12540)	2800	58.3	0.523	Y1530R	2.80(28.5)	63~241	127~305	2.0
PW-15	15.8	22.4	55.0(5607)	165.0(16800)	2000	95.0	1.943	Y2035R	2.14(21.8)	76~317	165~381	3.0

Dimensional Drawing for actuated position (External Gripping)

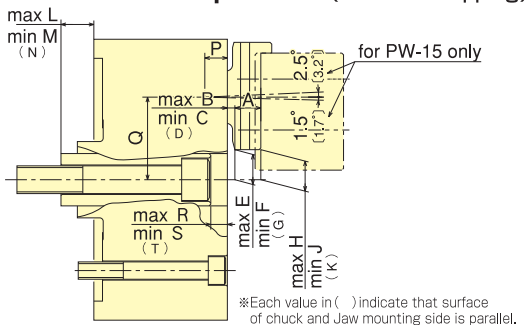

Dimensional Drawing for actuated position (Internal Gripping)

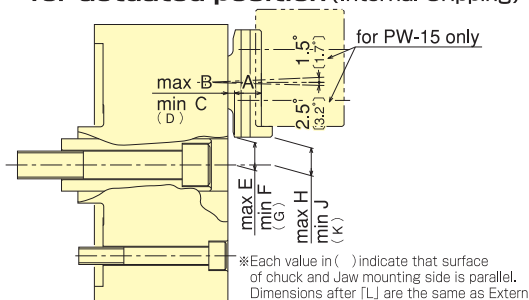

Dimensions for actuated position (External Gripping)

Model	A	B	C	D	E	F	G	H	J	K
PW-06	15.50	5.02	3.05	3.80	20.09	18.89	19.33	20.77	18.48	19.33
PW-08	18.50	5.68	3.24	4.80	22.63	21.18	22.10	23.08	20.36	22.10
PW-10	25.61	5.47	2.44	3.53	31.16	29.44	30.03	32.37	28.77	30.03
PW-12	25.61	5.47	2.44	3.53	51.81	50.09	50.68	53.02	49.42	50.68
PW-15	28.67	6.27	2.35	3.73	75.85	73.76	74.45	77.45	72.91	74.45

Model	L	M	N	P	Q	R	S	T
PW-06	24.0	12.6	18.95	13.20	47.63	14.60	3.20	9.55
PW-08	29.30	15.10	22.95	16.40	57.15	18.50	4.30	12.17
PW-10	34.90	17.40	27.05	19.30	71.43	19.60	2.10	11.75
PW-12	34.90	17.40	27.05	19.30	92.08	19.60	2.10	11.75
PW-15	48.70	26.30	38.40	20.07	120.65	24.90	2.50	14.60

Dimensions for actuated position (Internal Gripping)

Model	A	B	C	D	E	F	G	H	J	K
PW-06	15.03	5.66	3.43	4.27	16.32	15.08	15.53	17.25	14.52	15.53
PW-08	16.71	8.35	5.56	6.62	18.04	16.41	17.00	18.99	15.84	17.00
PW-10	20.51	10.92	7.23	8.63	19.59	17.61	18.33	20.74	16.92	18.33
PW-12	20.51	10.92	7.23	8.63	40.24	38.26	38.98	41.39	37.57	38.98
PW-15	23.94	12.19	6.44	8.46	54.75	52.23	53.05	56.41	51.35	53.05



CHUCK

2-Jaw Power Wing Chuck PWT(C) series

※PWC has the same specification as PW with the exception of the fact that PWC is a compensation type.

Draw down irregular shaped materials for steady gripping
PWT(C) for gripping of square or flange castings or forgings

- Two jaw type for gripping irregular workpieces
Draw down action ensures secure gripping of workpiece onto a reference surface.
- Compatible with PW series and soft jaws
*CE correspondence



Advanced Chuck

Dimensional Drawings

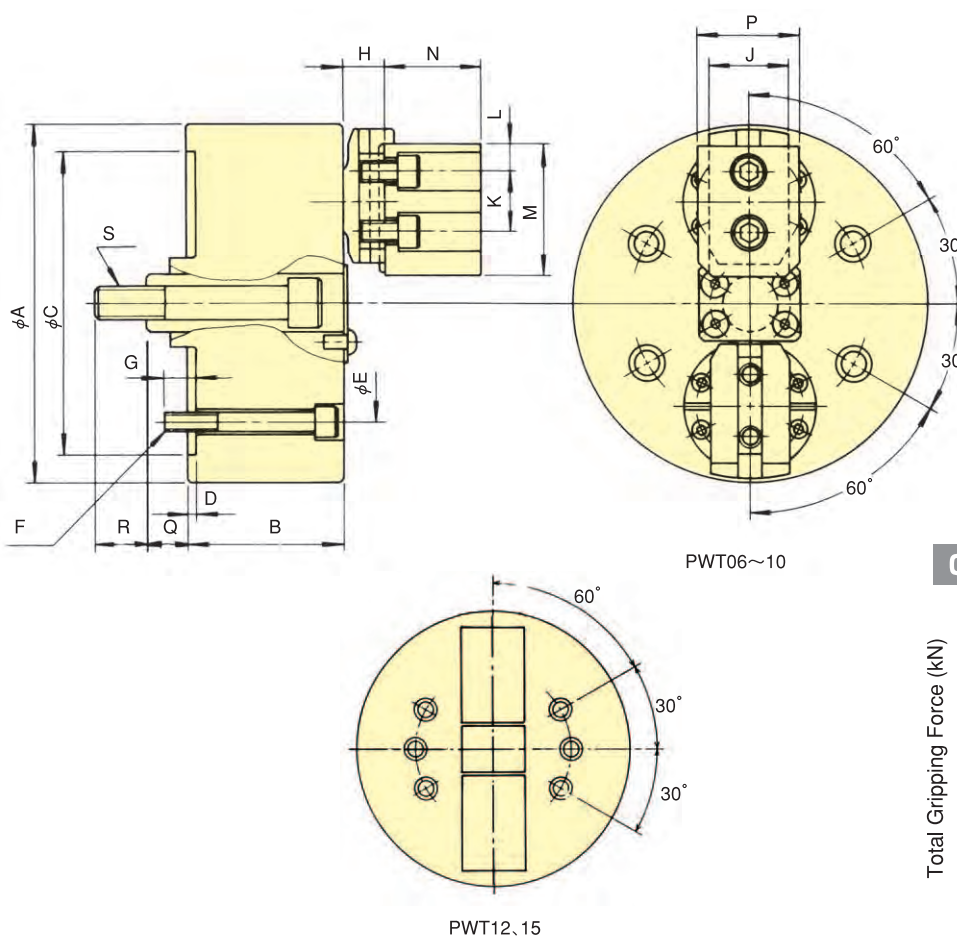

Gripping Performance

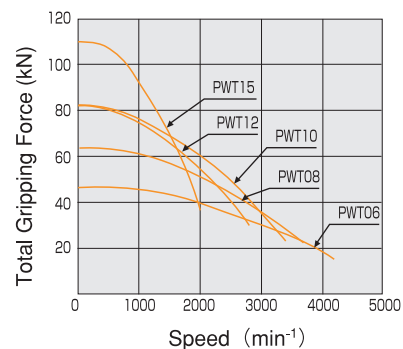

Dimensions

Dimensions Model	A	B	C(H6)	D	E	F	G	H	J	K	L	M	N	P	Q max.	Q min.	R	S
PWT06	162	77	140	5	104.8	4-M10	14	19.3	38.07	29.36	15	67.5	47.7	50.8	24	12.6	25.4	M16
PWT08	200	88	170	5	133.4	4-M12	18	23.33	44.45	34.14	15	74	54.17	57	29.3	15.1	29.2	M18
PWT10	254	105	220	5	171.4	4-M16	25	29.14	57.1	44.45	19	89.5	66.9	70.1	34.9	17.4	34.7	M22
PWT12	300	105	220	5	171.4	6-M16	25	29.14	57.1	44.45	19	108.5	66.9	70.1	34.9	17.4	34.7	M22
PWT15	381	117	300	5	235	6-M20	30	32.4	66.62	53.98	23.9	140	73.2	76.2	48.7	26.3	41	M27

Specifications

Specs Model	Jaw stroke (diameter) mm	Plunger stroke mm	Max. pull force kN(kgf)	Max. gripping force kN(kgf)	Max speed min ⁻¹	Mass (with Standard Soft Jaw) kg	Moment of inertia kg · m ²	Matching cylinder	Max. pressure MPa(kgf·cm ²)	Gripping range	
										external φ mm	internal φ mm
PWT06	7.9	11.4	15.5(1581)	46.6 (4752)	4200	14.0	0.047	Y1225R	1.60(16.3)	12.7~120	70~152
PWT08	9.5	14.2	21.3(2172)	64.0 (6526)	3700	24.0	0.120	Y1225R	2.10(21.4)	16~152	76~203
PWT10	12.7	17.5	27.3(2784)	82.0 (8362)	3400	46.0	0.378	Y1530R	1.85(18.9)	50~203	85~235
PWT12	12.7	17.5	27.3(2784)	82.0 (8362)	2800	63.0	0.720	Y1530R	1.82(18.6)	63~241	127~305
PWT15	15.8	22.4	36.7(3742)	110.0(11217)	2000	112.0	2.130	Y2035R	1.40(14.3)	76~317	165~381



CHUCK

Open Centre Pull Lock Chuck PUB series

Draw down for high-precision processing
Open Centre type accommodates shaft processing

* CE correspondence

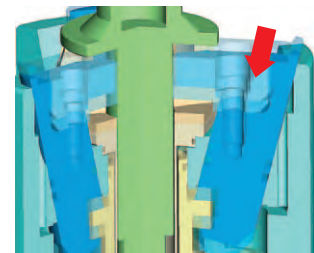
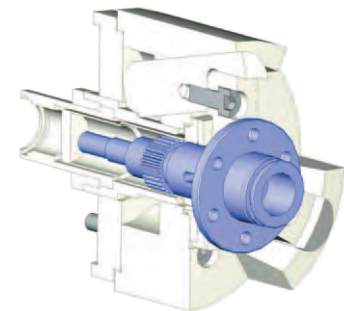

Advanced Chuck

Work Examples

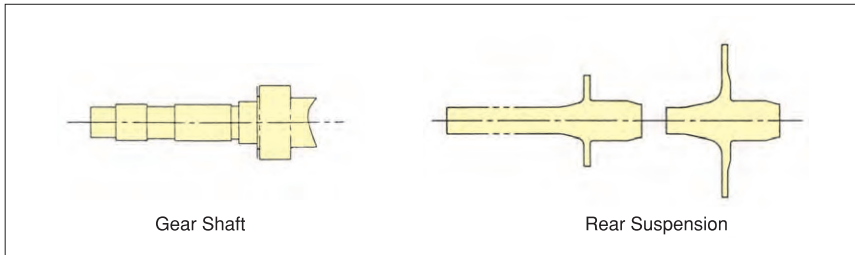

Gripping Examples

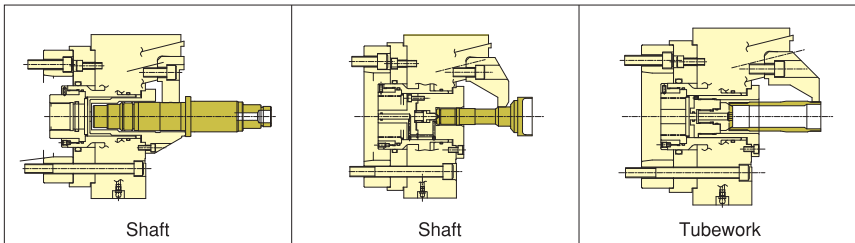

Dimensional Drawings

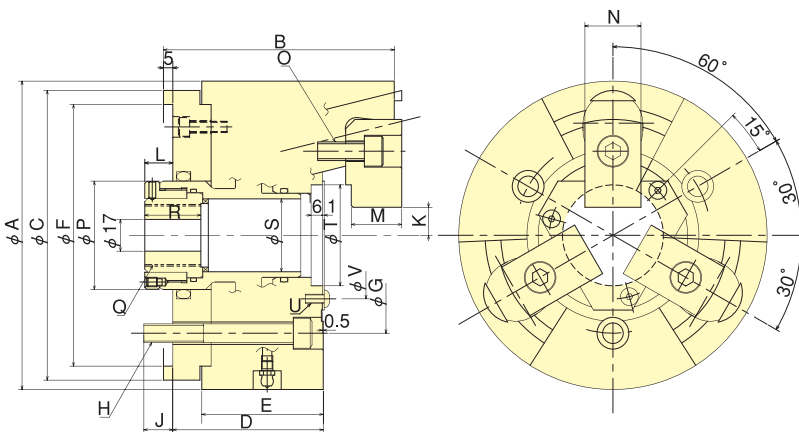

Gripping Performance

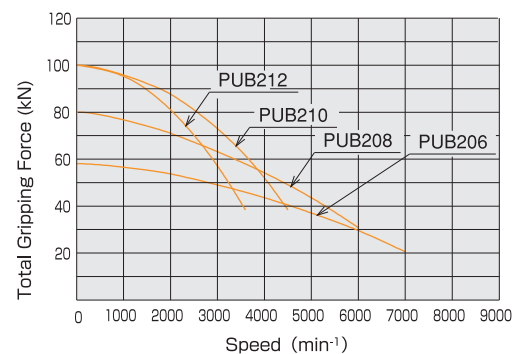

Dimensions

Model	A	B	C	D	E	F (G7)	G	H	J	K max.	K min.	L max.	L min.	M	N	O	P	Q max.	R	S	T (H6)	U	V
PUB206	165	123.5	155	80.5	65	140	104.8	3-M10	15.5	16.25	13.75	20	10	27	30	3-M10	58	M33x1.5	30	39	54	3-M5	68
PUB208	210	143	180	93	70	170	133.4	3-M12	17	16.25	13.75	20	10	31	35	3-M12	79	M45x2.0	29.5	50	66	3-M6	80
PUB210	254	158	230	103	82	220	171.4	3-M16	23	21.25	18.75	24	14	35	40	3-M14	102	M65x2.0	35.5	72	90	3-M8	104
PUB212	304	163	240	103	82	220	171.4	3-M16	25	46.25	43.75	19	9	40	40	3-M14	135	M92x2.0	35.5	100	114	3-M10	130

Specifications

Model	Max. mm	Min. mm	Jaw stroke (diameter)/mm	Plunger stroke mm	Max. pull force kN(kgf)	Max. gripping force kN(kgf)	Max speed min⁻¹	Mass (with Standard Soft Jaw) kg	Moment of Inertia kg · m²	Matching cylinder	Max. pressure MPa(kgf/cm²)	Max. Through Hole in Seat confirmation Specification mm
PUB206	100	25	5	10	18.0 (1835)	58.0 (5914)	7000	14.4	0.053	Y1020R	2.55 (26.0)	φ29
PUB208	130	25	5	10	25.0 (2549)	80.0 (8158)	6000	25.3	0.140	Y1225R	2.50 (25.5)	φ41
PUB210	160	35	5	10	35.0 (3569)	100.0 (10197)	4500	43.5	0.355	Y1225R	3.35 (34.2)	φ61
PUB212	210	85	5	10	35.0 (3569)	100.0 (10197)	3600	60.5	0.675	Y1225R	3.35 (34.2)	φ87



CHUCK

Pull Lock Chuck PU series

Pull back chuck for external gripping



- **High gripping stability means heavy cutting is possible**
Radial gripping forces and strong pull back action allow stable heavy cutting.
- **Excellent repeatability!**
Side and rear support provided by the base jaws reduces the centrifugal gripping force loss thus resulting in high repeatability.
- **Long-term stable accuracy!**
The sophisticated mechanism and special steel design ensure longevity and gripping accuracy.
- **Compatible with automation by use of seating confirmation**
* CE correspondence

Advanced Chuck

Work Examples

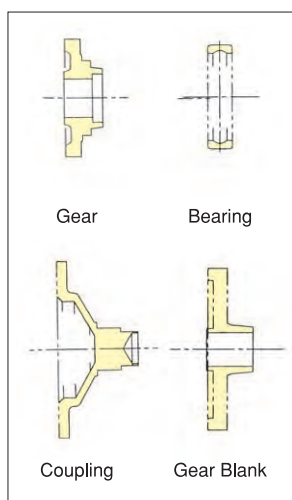

Gripping Examples

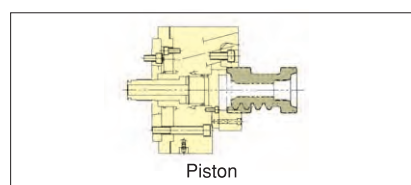

Gripping Performance

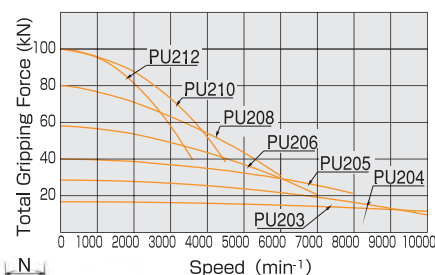

Dimensional Drawings

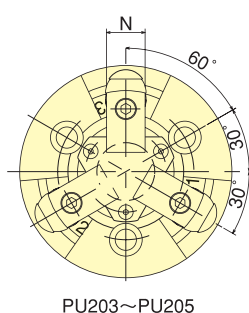
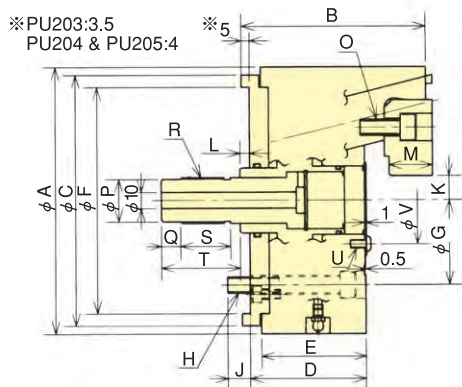

PU203~PU205

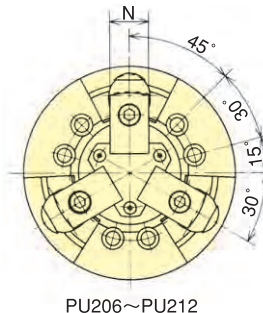

PU206~PU212

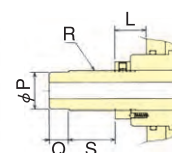

PU203~PU205
(Drawbar connection)

Dimensions

Model	A	B	C	D	E	F (G7)	G	H	J	K max.	K min.	L max.	L min.	M	N	O	P	Q	R	S	T	U	V
PU203	75	54.5	75	38.5	34	69	54	3-M6	9	2.5	1.5	21.5	17.5	9	15	3-M5	8	10	M10	19	-	3-M3	25.5
PU204	110	72.5	100	51	43	85	70.6	3-M10	12	10.75	9.25	19	13	14	20	3-M6	18	12	M20x1.5	24	-	3-M4	42
PU205	135	84.5	135	59	51	110	82.6	3-M10	15	13.25	11.75	23	17	17	24	3-M8	23	12	M25x1.5	30	-	3-M5	52
PU206	165	115	155	72	65	140	104.8	6-M10	14	16.25	13.75	11	1	27	30	3-M10	26	12	M28x1.5	31	49	3-M5	54
PU208	210	135	180	85	70	170	133.4	6-M12	15	16.25	13.75	11	1	31	35	3-M12	32	15	M35x1.5	30	51	3-M6	65
PU210	254	150	230	95	82	220	171.4	6-M16	23	21.25	18.75	12	2	35	40	3-M14	35	15	M38x1.5	30	51	3-M8	80
PU212	304	155	240	95	82	220	171.4	6-M16	23	46.25	43.75	12	2	40	40	3-M14	42	15	M45x1.5	30	51	3-M10	100

Specifications

Model	Max. mm	Min. mm	Jaw stroke (diameter) mm	Plunger stroke mm	Max. pull force kN(kgf)	Max. gripping force kN(kgf)	Max speed min⁻¹	Mass (with Standard Soft Jaw) kg	Moment of inertia kg·m²	Matching cylinder	Max. pressure MPa(kgf/cm²)
PU203	32	4	2	4	5.8 (590)	16.7 (1700)	10000	1.5	0.0012	YG-329	1.63 (16.6)
PU204	60	10	3	6	10.0 (1020)	28.5 (2906)	8000 10000	3.8	0.006	F0933H YG-296	2.06 (21.0) 1.18 (12.0)
PU205	84	15	3	6	14.0 (1428)	40.0 (4079)	8000	6.6	0.017	F0933H	2.50 (25.5)
PU206	100	25	5	10	18.0 (1835)	58.0 (5914)	7000	14.1	0.050	Y1020R	2.55 (26.0)
PU208	130	25	5	10	25.0 (2549)	80.0 (8158)	6000	24.0	0.133	Y1225R	2.50 (25.5)
PU210	160	35	5	10	35.0 (3569)	100.0 (10197)	4500	42.0	0.338	Y1225R	3.35 (34.2)
PU212	210	85	5	10	35.0 (3569)	100.0 (10197)	3600	60.5	0.655	Y1225R	3.35 (34.2)



CHUCK

Pull Lock Chuck PUE series

Pull back chuck for internal gripping

* CE correspondence



Work Examples

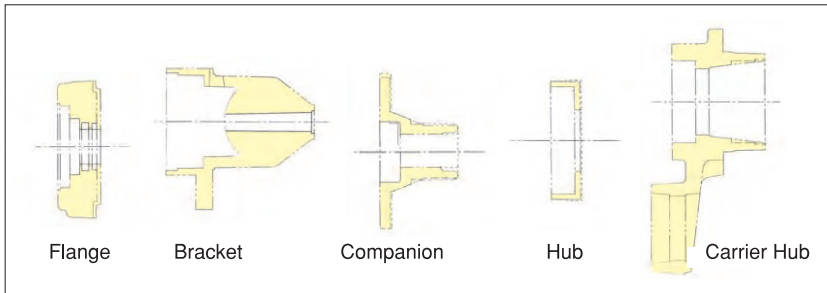

Gripping Examples

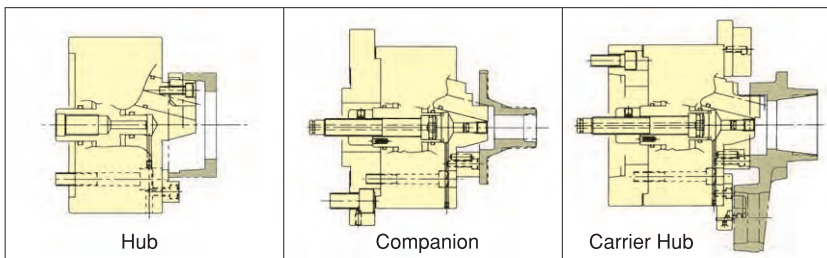

Gripping Performance

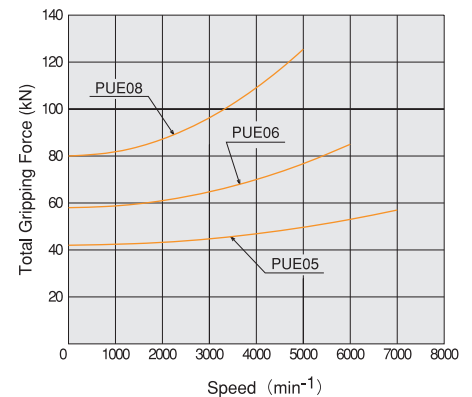

Advanced Chuck

Dimensional Drawings

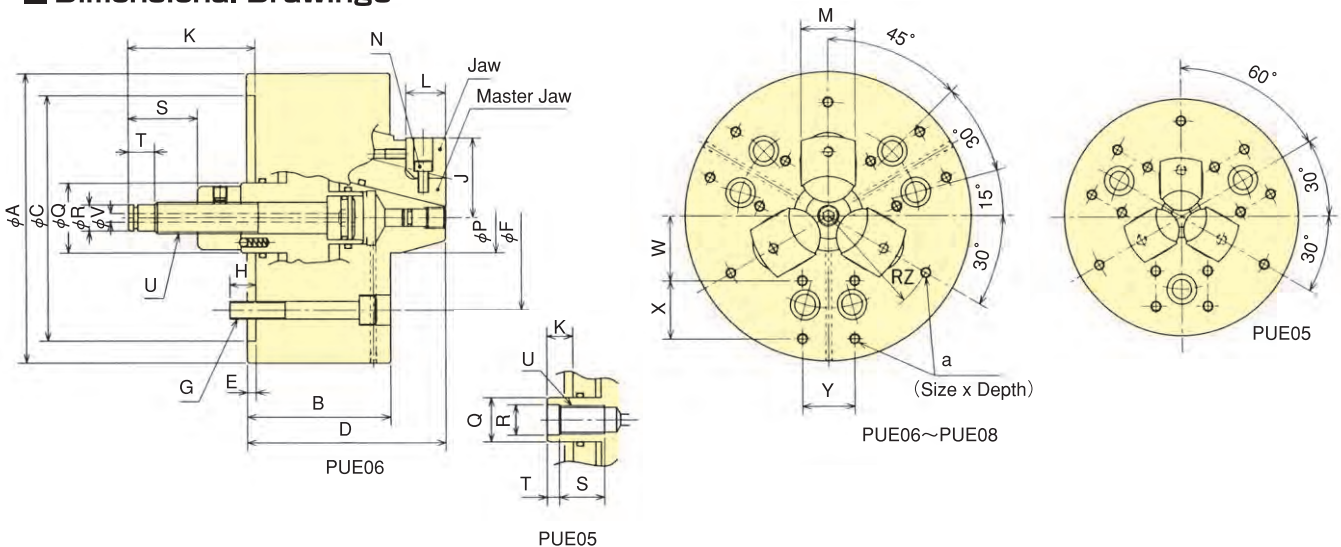

Dimensions

Model	A	B	C(G7)	D	E	F	G	H	J max.	J min.	K max.	K min.	L	M	N	P	Q	R	S	T	U	V	W	X	Y	Z	a
PUE05	135	72	110	98	5	82.55	3-M10	15	34.4	33	18	12	20	24	3-M6	24	25	17 ^{±0.1}	26	7	M16x2	—	31	20	30	55	M6x11
PUE06	165	83	140	115	5	104.8	6-M10	15	46.9	44.5	78.5	68.5	23	31	3-M6	40	40	15h8	40	15	M18x2.5	5	37	33	30	65	M6x11
PUE08	210	94	170	139	5	133.4	6-M12	17	57.2	54.8	91.5	81.5	23	35	3-M6	49	40	15h8	47.5	15	M20	5	45	40	30	80	M6x11

Specifications

※When using PUE-05 at more than 6000 rpm, a special cylinder is required.

Model	Jaw stroke (diameter)/mm	Plunger stroke/mm	Max. pull force kN(kgf)	Max. gripping force kN(kgf)	Max speed min ⁻¹	Mass (with Standard Soft Jaw) kg · m ³	Moment of inertia kg · m ²	Matching cylinder	Max. pressure MPa(kgf·cm ²)	Gripping range		
										Standard jaws	Option jaws	Master jaws
PUE05	2.8	6	13.0(1325)	42.0(4280)	7000	7.6	0.018	Y1020R [※]	1.90(19.5)	φ50~φ65	φ65~φ80	φ29~φ50
PUE06	4.8	10	18.0(1835)	58.0(5914)	6000	13.9	0.043	Y1020R	2.50(25.5)	φ70~φ89	φ89~φ105	φ44~φ70
PUE08	4.8	10	24.8(2529)	80.0(8158)	5000	26.8	0.144	Y1020R	3.40(34.5)	φ90~φ110	φ110~φ150	φ50~φ90



CHUCK

Level Lock Chuck LU series

Economical pull back chuck

- Suitable for gripping castings and forgings with draft angle
- Long Jaw Stroke
- Stable gripping accuracy



Gripping Examples

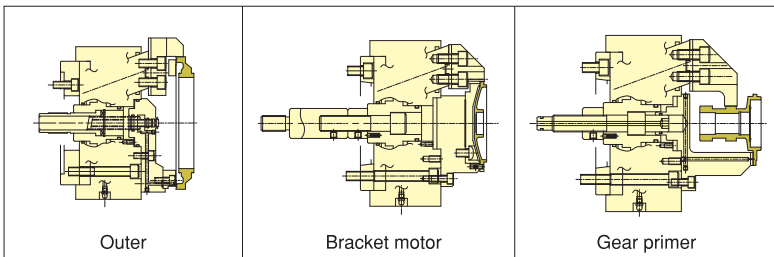

Gripping Performance

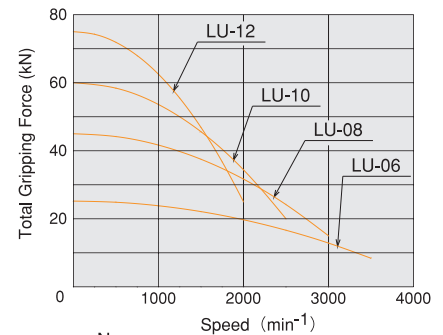

Dimensional Drawings

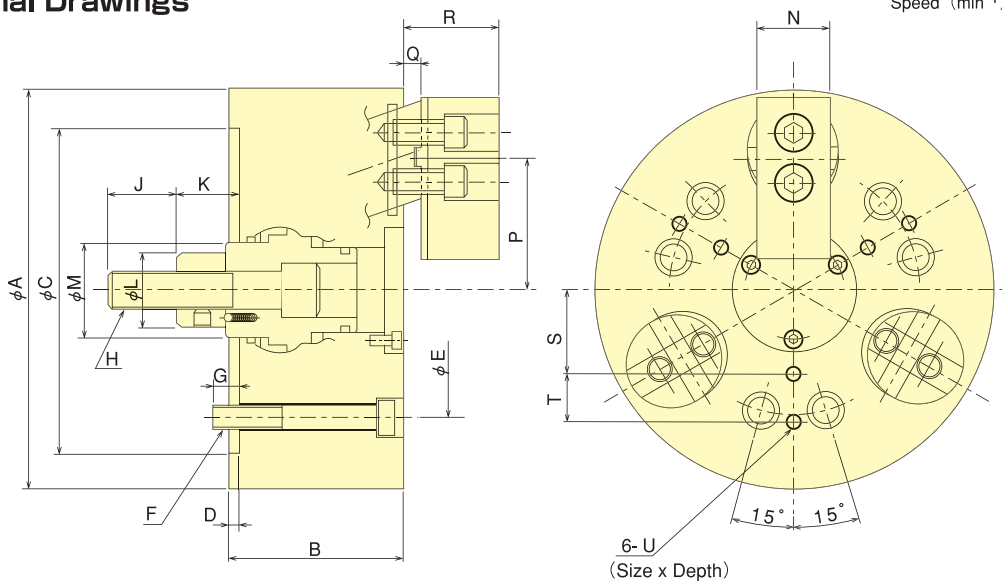

Dimensions

Model	A	B	C	D	E	F	G	H	J	K (max.)	K (min.)	L	M	N	P (max.)	P (min.)	Q (max.)	Q (min.)	R (max.)	R (min.)	S	T	U
LU-06	165	80	140	5	104.8	6-M10	16	M16x2.0	36	33	23	32	35	35	58.0	54.4	14	4	45	35	35	20	M6x12
LU-08	210	90	170	5	133.4	6-M12	15	M20x2.5	36	38	28	38	50	40	70.8	67.2	15	5	56	46	45	25	M8x15
LU-10	254	110	220	5	171.4	6-M16	24	M24x3.0	46	47	32	50	60	50	85.0	79.6	19	4	65	50	55	30	M8x15
LU-12	304	125	220	5	171.4	6-M16	24	M27x3.0	50	47	32	50	60	60	102.0	96.6	19	4	70	55	70	35	M10x17

Specifications

Model	Jaw stroke (diameter) mm	Plunger stroke mm	Max. pull force kN(kgf)	Max. gripping force kN(kgf)	Max speed min⁻¹	Mass kg	Moment of Inertia kg · m²	Matching cylinder	Max. pressure MPa(kgf/cm²)	Gripping range mm
LU-06	7.2	10	15.0 (1530)	25.2 (2570)	3500	13.7	0.045	Y1020R	2.15 (21.9)	35~165
LU-08	7.2	10	25.0 (2549)	45.0 (4589)	3000	26.0	0.143	Y1225R	2.50 (25.5)	40~210
LU-10	10.8	15	35.0 (3569)	60.0 (6118)	2500	45.5	0.373	Y1225R	3.30 (34.0)	50~254
LU-12	10.8	15	45.0 (4589)	75.0 (7648)	2000	68.0	0.800	Y1530R	3.00 (30.6)	50~304

Advanced Chuck



CHUCK

Finger Chuck FG series

Face clamping chuck, ideal for thin walled workpieces

- Distortion is reduced by using face clamping on thin section parts
 - Using the aluminium rear body allows for high speed rotation, thus saving machining time
 - Jaws include equalising mechanism to securely grip parts with variable thickness (Equalization amount/2.5 mm max)
 - Through hole allows pneumatic accessories
- * CE correspondence



Dimensional Drawings

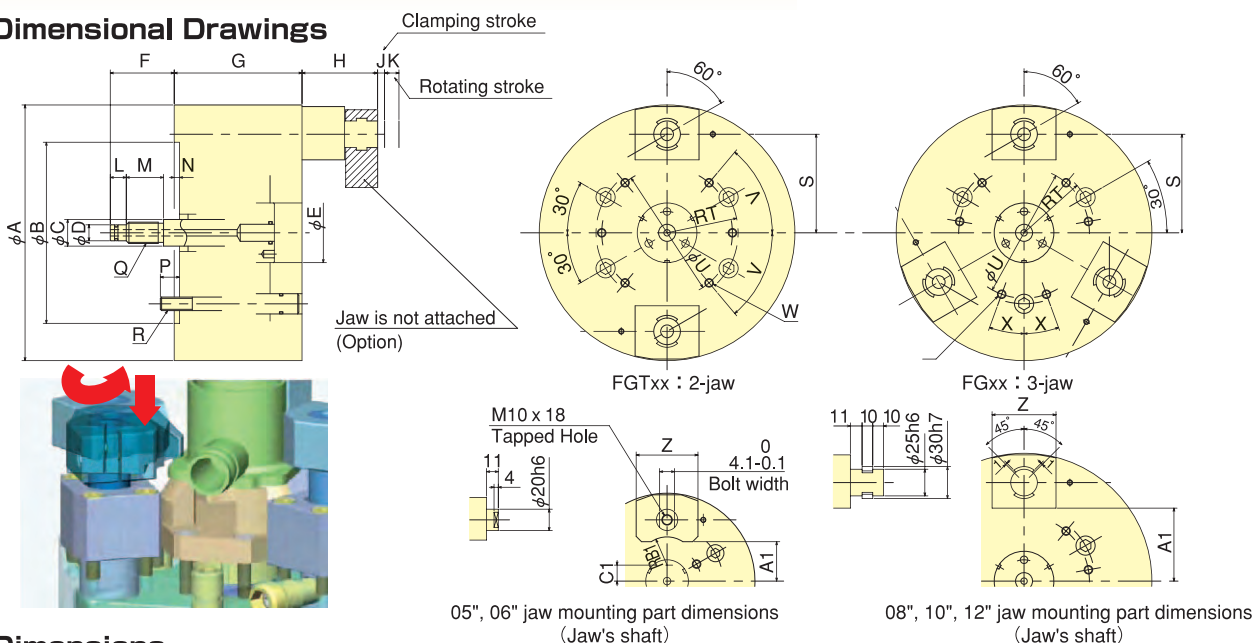

Dimensions *FGT : 2-jaw, FG : 3-jaw

Model	A	B	C	D	E	F	G	H	J	K	L	M	N	P	Q	R	S	T	U	V	W	X	Y	Z	A1	B1	C1
FGT05/FG05	135	110	14	9	37	50-70	110	36-56	8	12	15	30	5	14	M12	M10	42.5	41.3	50	30°	4-M6 screw depth 12	-	3-M6 screw depth 12	58	22	26.5	-
FGT06/FG06	165	140	16	12	40	50-70	110	36-56	8	12	15	30	5	14	M16	M10	57.5	52.4	64	30°	4-M8 screw depth 15	-	3-M8 screw depth 15	58	37	26.5	15
FGT08/FG08	210	170	25	16	56	50-70	120	71-91	8	12	15	30	5	18	M20	M12	77.5	66.7	104	50°	6-M8 screw depth 15	20°	6-M8 screw depth 15	60	53.5	-	-
FGT10/FG10	254	220	25	16	56	50-70	120	71-91	8	12	15	30	5	24	M20	M16	99.5	85.7	140	50°	6-M8 screw depth 15	20°	6-M8 screw depth 15	60	75.5	-	-
FGT12/FG12	304	220	25	16	56	50-70	120	71-91	8	12	15	30	5	24	M20	M16	124.5	85.7	190	50°	6-M8 screw depth 15	20°	6-M8 screw depth 15	60	100.5	-	-

Specifications *FGT : 2-jaw, FG : 3-jaw *1-Jaw length : 30mm *2-Jaw length : 40mm

Model	Max. Allowable kN(kgf)	Max speed min ⁻¹	Mass kg	Moment of Inertia kg · m ²	Matching cylinder	Clamping stroke mm	Clamping force of a jaw kN(kgf)*1	Max. Gripping dia. mm	Limit height by optional jaw	Equalizing q'ty mm	Cylinder with seating
FGT05 / FG05	5.0 (510) / 7.5 (765)	4000	10.0 / 12.0	0.025 / 0.030	Y1020R	8	2.0(204)*1	52	41	1	Y1020RE09C
FGT06 / FG06	6.0 (612) / 9.0 (918)	4000	11.0 / 13.0	0.045 / 0.050	Y1020R	8	2.5(255)*1	78	41	1.5	Y1020RE09C
FGT08 / FG08	12.0(1224) / 18.0(1835)	3500	22.0 / 24.0	0.130 / 0.140	Y1020R	8	5.5(561)*2	105	61	2	Y1020RE09C
FGT10 / FG10	12.0(1224) / 18.0(1835)	3500	34.0 / 36.0	0.290 / 0.310	Y1020R	8	5.5(561)*2	150	61	2	Y1020RE09C
FGT12 / FG12	12.0(1224) / 18.0(1835)	3000	46.0 / 48.0	0.570 / 0.590	Y1020R	8	5.5(561)*2	200	61	2.5	Y1020RE09C

Dimensional Drawings for Blank Jaws (Option)

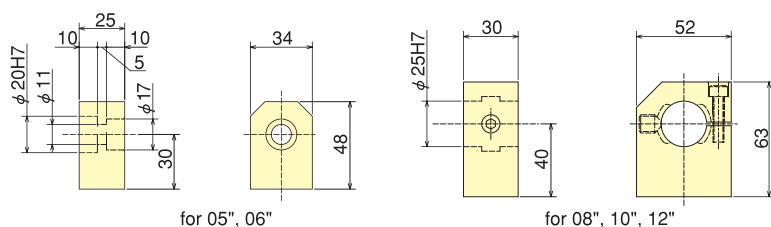

Gripping Examples

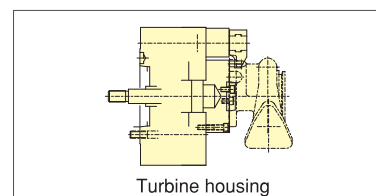



CHUCK

Finger Chuck for Automotive Wheels

FG-V series

Rigid body
Finger Chuck for aluminium wheel
machining for automobiles

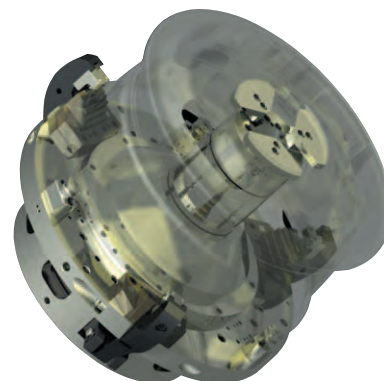

Gripping Examples

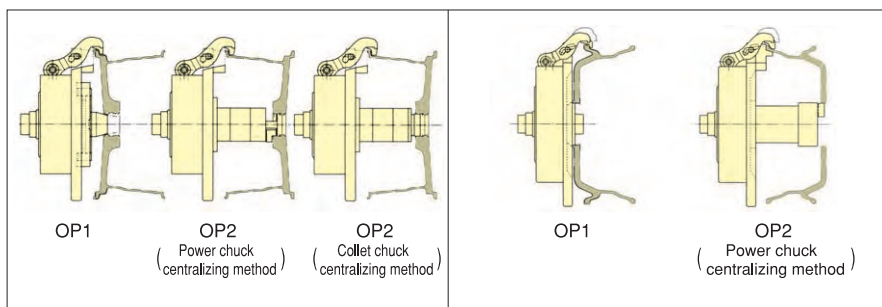

Advanced Chuck

Dimensional Drawings

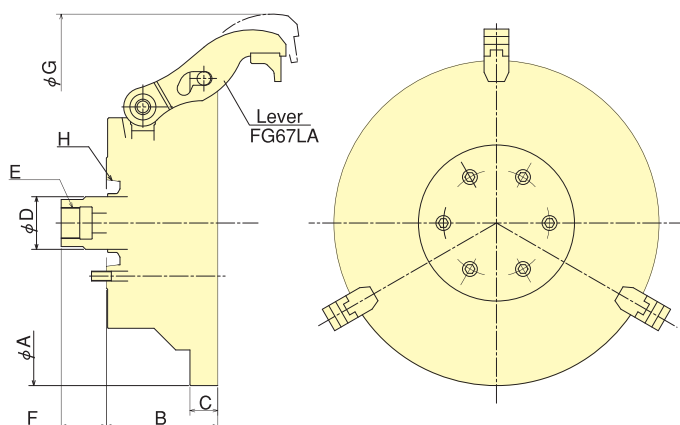

Dimensions

Model	A	B	C	D	E	F max.	F min.	G	H
FG50V	525	180	45	85	M50×1.5	73	38	675	A2-8
FG56V	575	180	45	85	M50×1.5	73	38	725	A2-11
FG62V	625	180	45	85	M50×1.5	73	38	775	A2-11

Specifications

Model	Max. plunger thrust kN(kgf)	Max. speed min ⁻¹	Mass kg	Moment of inertia kg·m ²	Open jaw stroke/Clamping stroke mm	Gripping force/jaw kN(kgf)
FG50V	30.0 (3059)	2500	135.0	3.750	18.5/16.5	9.5 (969)
FG56V	30.0 (3059)	2500	190.0	5.800	18.5/16.5	9.5 (969)
FG62V	30.0 (3059)	2500	220.0	8.800	18.5/16.5	9.5 (969)

Measurement table for Wheel

Model	12"	13"	14"	15"	16"	17"	18"	19"	20"	21.5"	22.5"
FG50V		○	○	○	○	○	○				
FG56V		○	○	○	○	○	○	○	○		
FG62V					○	○	○	○	○	○	○



CHUCK

Finger Chuck for Automotive Wheels

FG-L series

Standard Finger Chuck

Light-Weight body for aluminium wheel machining for automobiles

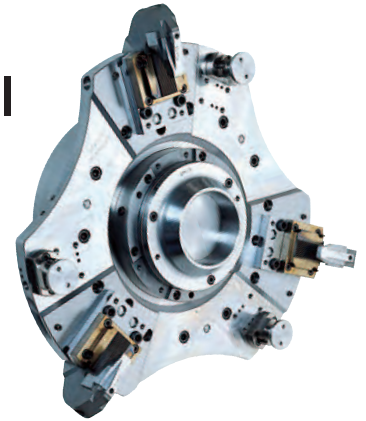

● High Speed

A technological breakthrough in the design has allowed a max speed of 3000 min⁻¹ for each wheel size (13"-18").

Gripping Examples

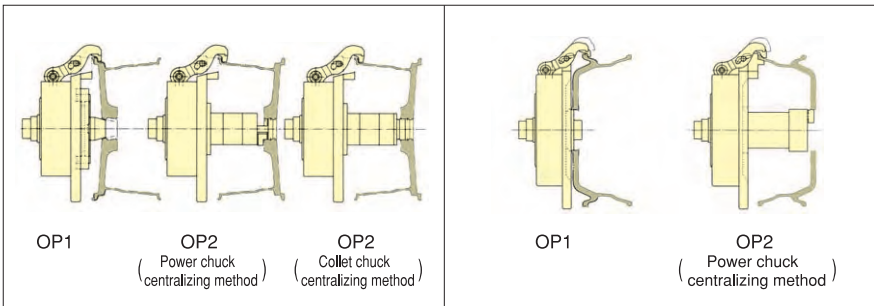

Advanced Chuck

Dimensional Drawings

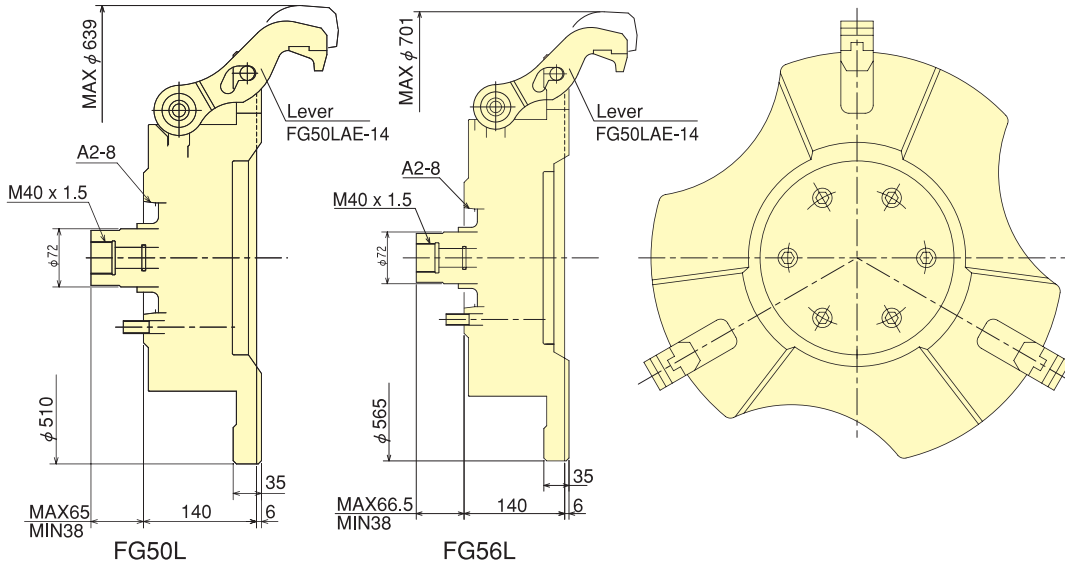

Dimensions

Model	Specs	Max. plunger thrust kN(kgf)	Max. speed min ⁻¹	Mass kg	Moment of Inertia kg · m ²	Open jaw stroke/Clamping stroke mm	Gripping force/jaw kN(kgf)
FG50L		30.0 (3059)	3000	97.0	2.350	17/10	9.5 (969)
FG56L		30.0 (3059)	2500	116.0	3.320	18.5/10	9.5 (969)

Measurement Table for Wheel

Model	Wheel size	12"	13"	14"	15"	16"	17"	18"	19"	20"	21.5"	22.5"
FG50L			○	○	○	○	○	○				
FG56L			○	○	○	○	○	○	○	○		



CHUCK

6-Jaw Finger Chuck for Motorcycle Wheels FG-M series

Finger Chuck ideally suited for aluminium wheel machining for motorcycles

- High Stability
The floating mechanism ensures firm chucking.

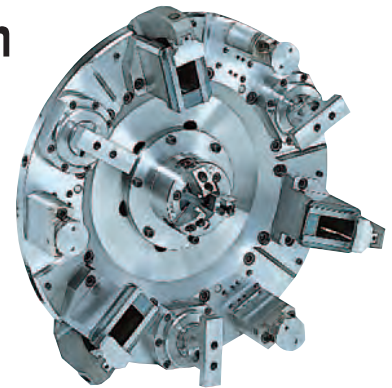

Gripping Examples

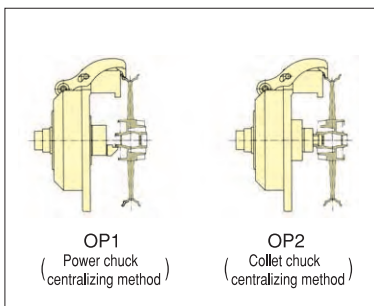

OP1
Power chuck
(centralizing method)

OP2
Collet chuck
(centralizing method)

Dimensional Drawings

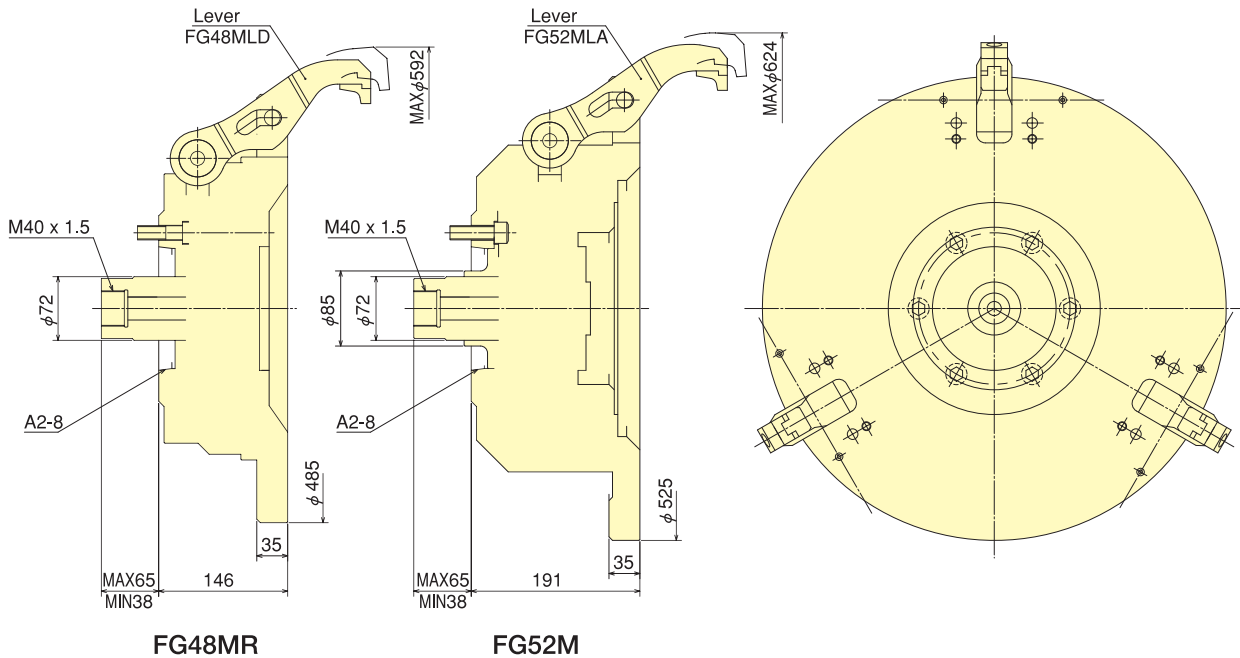

FG48MR

FG52M

Dimensions

Model	Specs	Max. plunger thrust kN(kgf)	Max. speed min ⁻¹	Mass kg	Moment of Inertia kg · m ²	Open jaw stroke/Clamping stroke mm	Gripping force/jaw kN(kgf)
FG48MR		12.0 (1224)	2500	91.0	1.780	14/13	3.5 (357)
FG52M		21.0 (2141)	2500	130.0	3.650	14/13	6.5 (663)

Measurement table for Wheel

Model	Wheel size	12"	13"	14"	15"	16"	17"	18"	19"	20"	21.5"	22.5"
FG48MR		○	○	○	○	○	○	○				
FG52M		○	○	○	○	○	○	○	○			



CHUCK

Easy Preparation Finger Chuck FG-Q series

Quick setup for size changes
Finger Chuck ideally suited for aluminium wheel machining for automobiles

- Easy preparation for each size of Wheel
 - The setup time is approximately 30 seconds
- Due to the preparation for each size, three levers and fixed jigs are moved simultaneously simply by rotating the handle, thus saving the setup time.

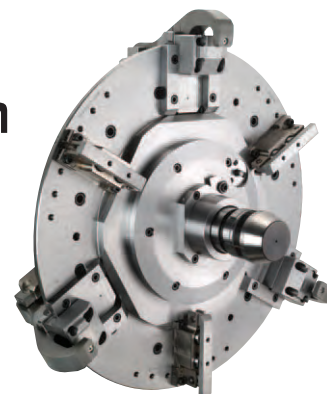

Advanced Chuck

Dimensional Drawings

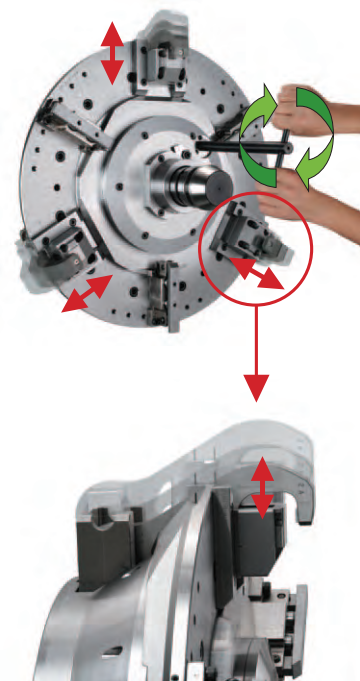
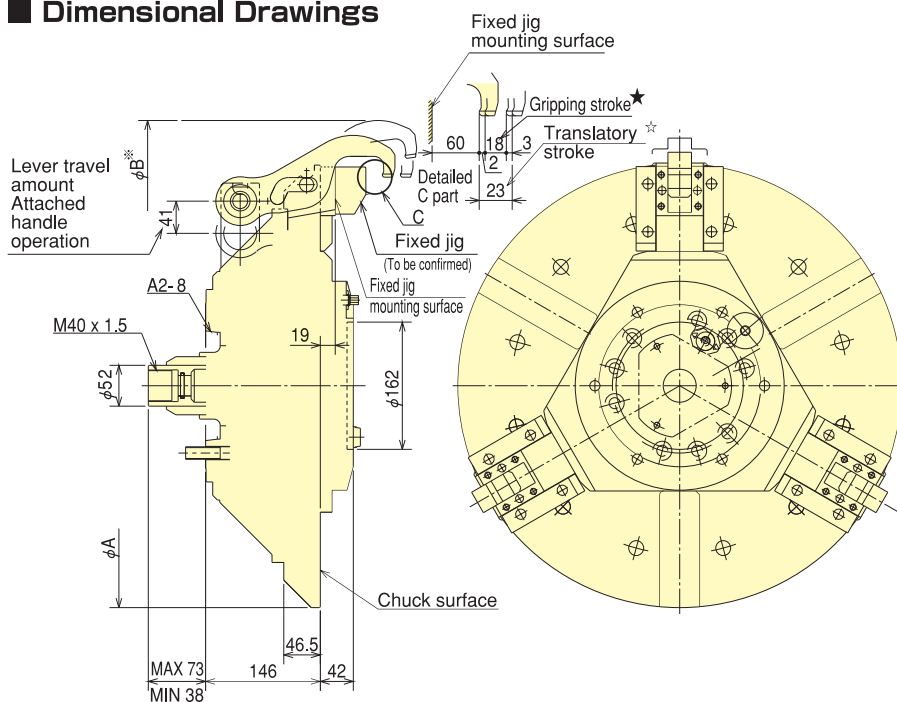

Dimensions

*B shows the state in use of the lever A.

Dimensions	A	B*
Model		
FG56Q	565	672
FG62Q	620	727

Specifications

Model	Jaw stroke			Max. plunger thrust kN(kgf)	Max. speed min ⁻¹	Mass kg	Moment of Inertia kg·m ²	Gripping force/jaw kN(kgf)
	Full stroke mm	Translatory/ gripping* stroke mm	Open jaw stroke mm					
FG56Q	35	23/18	12	30.0 (3059)	2500	117.5	4.130	9.5 (969)
FG62Q					2200	195.0	7.500	

Measurement table for Wheel

Model	Wheel size		13	14	15	16	17	18	19	20	21	22
	Lever											
FG56Q	A						○	○	○	○		
	C	○	○	○	○	○	○	○	○			
	B(option)			○	○	○	○	○	○			
FG62Q	A								○	○	○	○
	C			○	○	○	○	○	○	○	○	○
	B(option)						○	○	○	○	○	○



**ROTARY
CYLINDER**

▶ **P.55~P.65**

Cylinder

Cylinder

Cylinder Series exclusive for KITAGAWA Chucks

From standard to advanced type, a recognised line-up of high performance cylinders accommodates every KITAGAWA chuck.

When selecting the combination of chuck cylinders, contact us.



**ROTARY
CYLINDER**

Compact Style Hydraulic Cylinder with Open Centre SS series

**Accommodates BB200 and B-200 series
The compact design maximises Lathe performance**

- Compact : 30% reduction in length of current S series
- Speed Increased
- Can operate one size larger chuck due to increased pull forces

*CE correspondence (Only series with checking device)



Dimensional Drawings

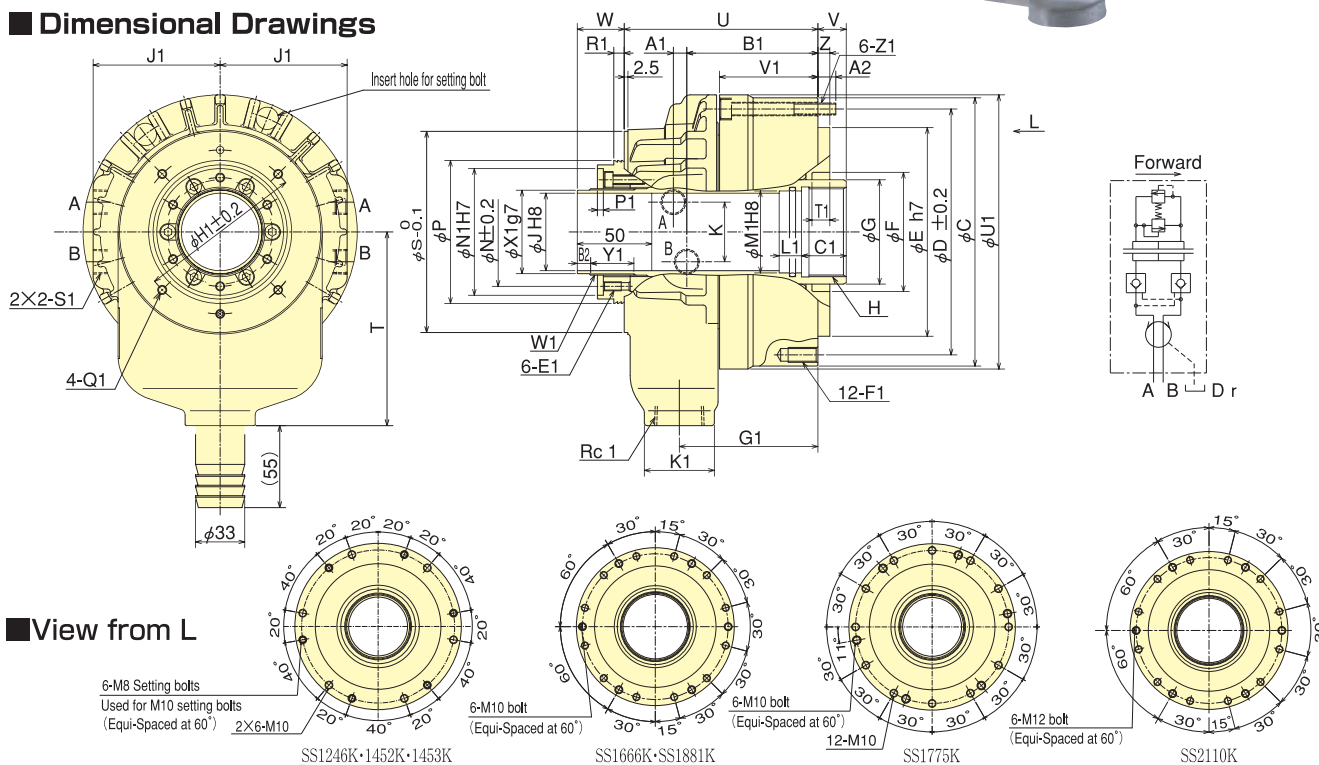

Dimensions

Model	C	D	E	F	G	H	J	K	N	P	S	T	U	V max.	V min.	W max.	W min.	Z	A1	B1	C1
SS1246K	162	147	130	75	65	M55×2	46	40	64	85	116	120	120	13	-3	45.0	29.0	8	8.5	79.5	25
SS1452K	180	165	140	80	70	M60×2	52	40	73	96	135	130	130	19	-3	53.5	31.5	8	9.0	88.0	30
SS1453K	180	165	140	80	70	M60×2	53	40	73	96	135	130	130	19	-3	53.5	31.5	8	9.0	88.0	30
SS1666K	207	190	168	95	85	M75×2	66	48	88	111	154	150	150	22	-3	58.0	33.0	8	13.0	99.5	35
SS1775K	212	195	160	105	95	M85×2	75	46	98	121	164	160	157	22	-3	57.0	32.0	8	17.5	99.0	35
SS1881K	222	205	168	110	100	M90×2	81	46	103	126	175	175	167	23	-2	58.0	33.0	8	17.0	106.0	35
SS2110K	260	240	200	135	125	M115×2	106	46	133	160	210	200	192	27	-3	64.0	34.0	8	20.0	120.5	35

Model	E1 depth	F1 depth	G1	H1	J1	K1	L1	M1	N1	P1	Q1 depth	R1	S1	T1	U1	V1	W1	X1	Y1	Z1	A2	B2
SS1246K	M6×10	M10×20	84	98	76	47	15	50	76	4	M5×6	6.5	Rc ³ / ₈	12	165	57.5	M52×1.5	50.0	29	M8	15	9
SS1452K	M6×12	M10×20	93	110	86	47	15	55	85	4	M6×6	7.0	Rc ³ / ₈	12	184	66.0	M58×1.5	56.0	30	M8	12	8
SS1453K	M6×12	M10×20	93	110	86	47	15	55	85	4	M6×6	7.0	Rc ³ / ₈	12	184	66.0	M58×1.5	56.0	30	M8	12	8
SS1666K	M6×12	M12×24	108	145	97	47	15	70	100	4	M6×10	16.5	Rc ¹ / ₂	12	211	71.0	M74×1.5	71.5	36	M10	18	9
SS1775K	M6×12	M10×20	110	155	100	47	15	80	108	4	M6×10	14.0	Rc ¹ / ₂	12	216	71.0	M84×2.0	81.0	33	M10	18	9
SS1881K	M6×12	M12×24	115	166	105	47	15	85	113	4	M6×10	16.5	Rc ¹ / ₂	12	226	71.0	M89×2.0	86.0	38	M10	18	9
SS2110K	M6×12	M12×24	130	201	124	47	15	110	145	4	M6×10	16.0	Rc ¹ / ₂	12	263	79.5	M118×2.0	115.0	45	M12	18	9

Specifications

Model	Piston Dia. mm	Piston stroke mm	Piston Area Push Side cm ²	Piston Area Pull Side cm ²	Draw bar Push Side kN(kgf)	Draw bar Pull Side kN(kgf)	Max. Operation Pressure MPa (kgf/cm ²)	Max. Speed min ⁻¹	Moment of inertia kg·m ²	Net Weight kg	Total leakage ℓ /min
SS1246K	128	16	102.6	91.5	43.6(4446)	38.9(3967)	4.50(45.9)	8000	0.017	8.0	3.0
SS1452K	145	22	132.9	122.6	56.5(5761)	52.1(5313)	4.50(45.9)	6500	0.031	13.0	3.9
SS1453K	145	22	132.9	122.6	56.5(5761)	52.1(5313)	4.50(45.9)	6500	0.031	13.0	3.9
SS1666K	165	25	166.1	152.9	70.6(7199)	65.0(6628)	4.50(45.9)	5600	0.065	19.0	4.0
SS1775K	170	25	166.4	152.2	70.7(7209)	64.6(6587)	4.50(45.9)	5500	0.061	18.5	4.2
SS1881K	180	25	187.1	172.0	79.5(8107)	73.1(7454)	4.50(45.9)	4800	0.087	24.0	4.3
SS2110K	210	30	229.8	218.5	74.7(7617)	71.0(7240)	3.50(35.7)	3500	0.197	37.0	6.0

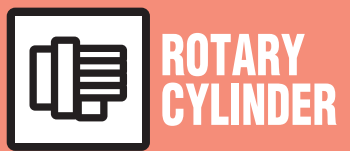

Large Thru-Hole High Speed Hydraulic Cylinder with Open Centre

S series

KITAGAWA standard thru-hole type

- Compact and light weight
- Built-in check valve and relief valve
- * CE correspondence (Only series with checking device)

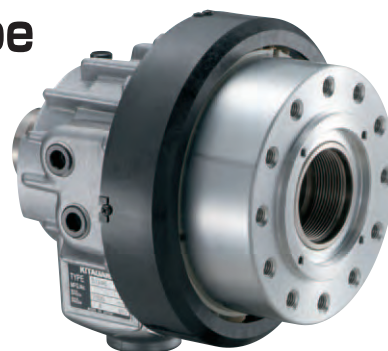

Dimensional Drawings

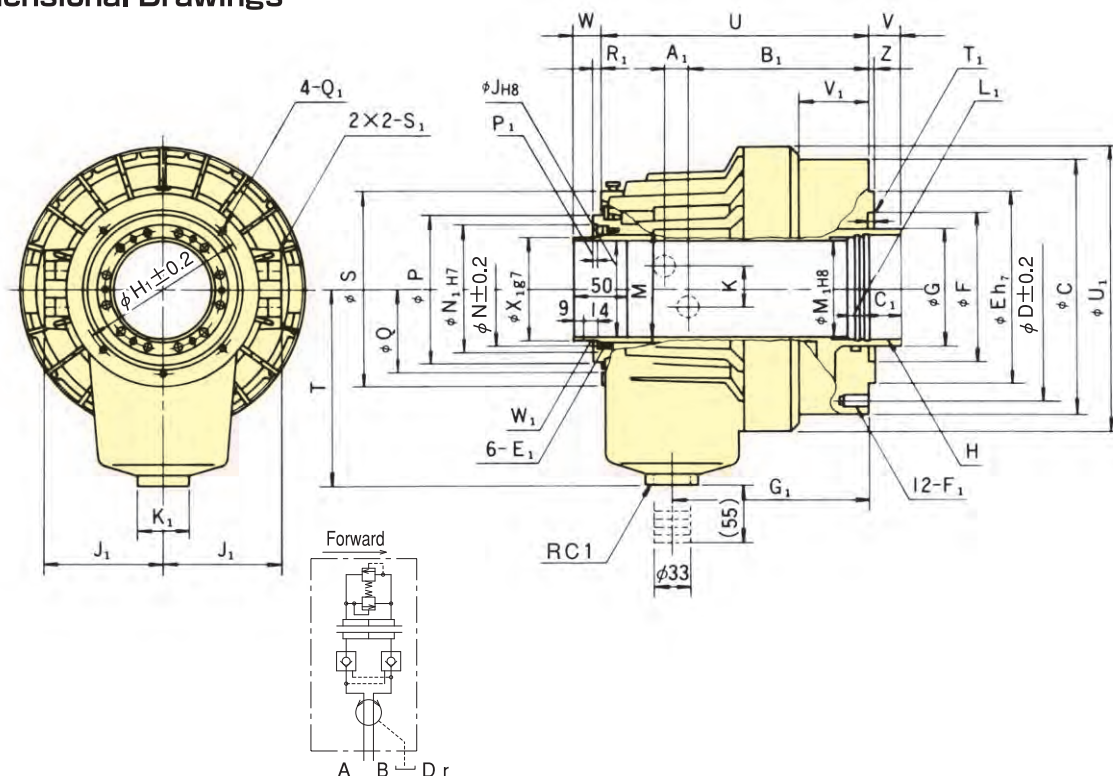

Dimensions

Model	C	D	E	F	G	H	J Thru-hole	K	M	N	P	Q	S	T	U	V max.	V min.	W max.	W min.	Z	A ₁
S1246	155	130	100	80	65	M 55×2.0	46	36	52.9	64	85	51.5	118	115	179	15	0	40	25	5	11.5
S1552	190	170	130	85	70	M 60×2.0	52	36	59.6	73	96	57.5	137	130	191	22	0	47	25	5	12
S1875	215	190	160	120	95	M 85×2.0	75	36	84.6	98	121	70.5	166	160	225	25	0	50	25	5	17.5
S2091	240	215	180	140	110	M100×2.0	91	34	99.6	108	138	79	182	185	248	30	0	55	25	5	21

Model	B ₁	C ₁	E ₁ depth	F ₁ depth	G ₁	H ₁	J ₁	K ₁	L ₁	M ₁	N ₁	P ₁	Q ₁ depth	R ₁	S ₁	T ₁	U ₁	V ₁	W ₁	X ₁
S1246	126.5	30	M6×9	M10×20	135	98	76	47	15	50	76	4	M5×10	6	RC1/2	6	200	46	M52×1.5	50
S1552	136	30	M6×9	M10×20	145	110	86	47	15	55	85	4	M6×12	7	RC1/2	6	220	51	M58×1.5	56
S1875	153.5	35	M6×9	M10×20	166.5	155	101	47	15	80	108	4	M6×12	7	RC1/2	6	242	58	M84×2.0	81
S2091	168	35	M6×14	M12×24	183	165	110	47	15	95	120	4	M6×12	7	RC1/2	6	267	66	M99×2.0	96

Specifications

*Total leakage : Pressure 3.00MPa (30.6kgf/cm²) and oil temperature 50°C. *Draw bar pull force : Pressure 4.00MPa (40.8kgf/cm²)

Model	Piston Dia. mm	Piston stroke mm	Piston Area		Draw bar		Max. Operation Pressure MPa (kgf/cm ²)	Max. Speed min ⁻¹	Moment of inertia kg·m ²	Net Weight kg	Total leakage ℓ /min
			Push Side cm ²	Pull Side cm ²	Push Side kN(kgf)	Pull Side kN(kgf)					
S1246	125	15	100	89	38.0 (3875)	33.0 (3365)	4.00 (40.8)	7000	0.019	12.0	3.0
S1552	155	22	161	150	60.0 (6118)	56.0 (5710)	4.00 (40.8)	6200	0.053	16.8	3.9
S1875	180	25	198	183	74.0 (7546)	69.0 (7036)	4.00 (40.8)	4700	0.095	26.0	4.2
S2091	205	30	252	234	94.0 (9585)	88.0 (8973)	4.00 (40.8)	3800	0.153	33.0	4.5

Cylinder



**ROTARY
CYLINDER**

Large Thru-Hole High Speed Hydraulic Cylinder with Open Centre S-L series

KITAGAWA standard thru-hole type

- Long piston stroke
- Built-in check valve and relief valve
- * CE correspondence (Only series with checking device)



Dimensional Drawings

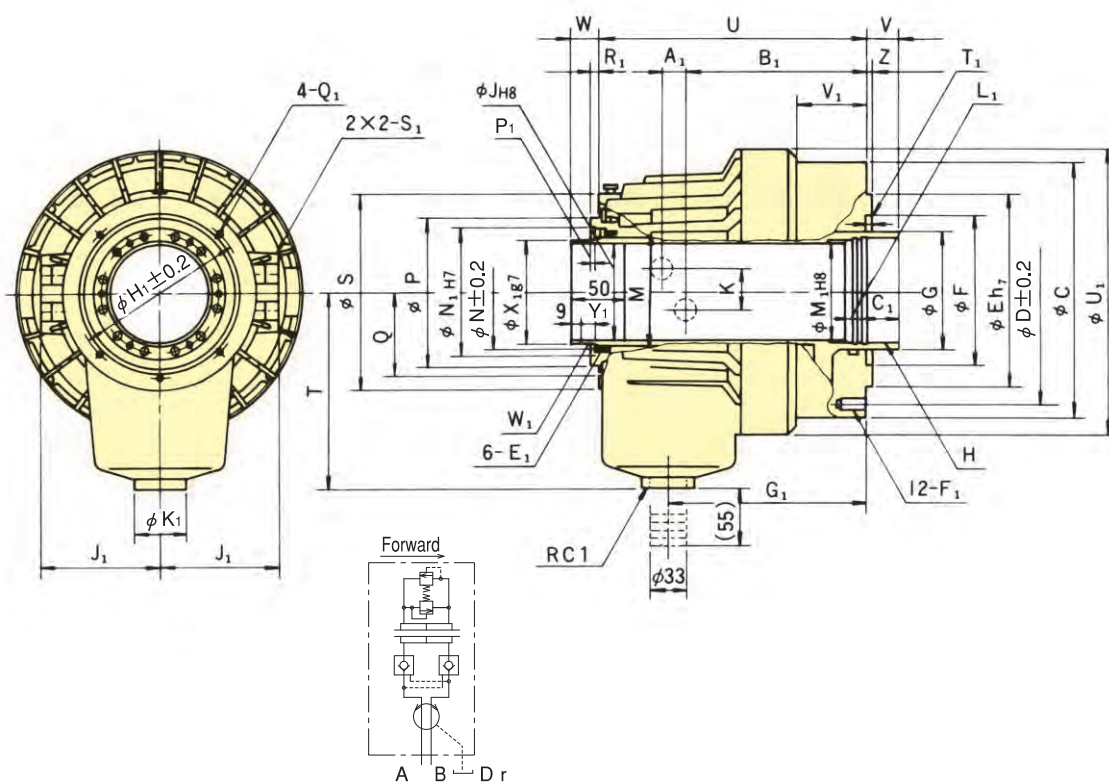

Dimensions

Dimensions Model	C	D	E	F	G	H	J Thru-hole	K	M	N	P	Q	S	T	U	V max.	V min.	W max.	W min.	Z	A ₁
S1246L	155	130	100	80	65	M55×2.0	46	36	52.9	64	85	51.5	118	115	200	27	-5	57	25	5	11.5
S1552L	190	170	130	85	70	M60×2.0	52	36	59.6	73	96	57.5	137	130	208	29	-5	59	25	5	12
S1875L	215	190	160	120	95	M85×2.0	75	36	84.6	98	121	70.5	166	160	241	35	-5	65	25	5	17.5
S2091L	240	215	180	140	110	M100×2.0	91	34	99.6	108	138	79	182	185	268	45	-5	75	25	5	21

Dimensions Model	B ₁	C ₁	Eidepth	Fidepth	G ₁	H ₁	J ₁	K ₁	L ₁	M ₁	N ₁	P ₁	Q ₁ depth	R ₁	S ₁	T ₁	U ₁	V ₁	W ₁	X ₁	Y ₁
S1246L	147.5	30	M6×9	M10×20	156	98	76	47	15	50	76	4	M5×10	6	RC1/2	12	200	67	M62×1.5	50	33
S1552L	153	30	M6×9	M10×20	162	110	86	47	15	55	85	4	M6×12	7	RC1/2	12	220	68	M68×1.5	56	33
S1875L	169.5	35	M6×9	M10×20	182.5	155	101	47	15	80	108	4	M6×12	7	RC1/2	12	242	74	M84×2.0	81	33
S2091L	188	35	M6×14	M12×24	203	165	110	47	15	95	120	4	M6×12	7	RC1/2	12	267	86	M99×2.0	96	38

Specifications *Total leakage : Pressure 3.00MPa (30.6kgf/cm²) and oil temperature 50°C. *Draw bar pull force : Pressure 4.00MPa (40.8kgf/cm²)

Specifications Model	Piston Dia. mm	Piston stroke mm	Piston Area		Draw bar		Max. Operation Pressure	Max. Speed	Moment of inertia	Net Weight	Total leakage
			Push Side cm ²	Pull Side cm ²	Push Side kN(kgf)	Pull Side kN(kgf)	MPa (kgf/cm ²)	min ⁻¹	kg·m ²	kg	ℓ /min
S1246L	125	32	100	89	38.0 (3875)	33.0 (3365)	4.00 (40.8)	7000	0.022	12.8	3.0
S1552L	155	34	161	150	60.0 (6118)	56.0 (5710)	4.00 (40.8)	6200	0.058	17.0	3.9
S1875L	180	40	198	183	74.0 (7546)	69.0 (7036)	4.00 (40.8)	4700	0.100	26.8	4.2
S2091L	205	50	252	234	94.0 (9585)	88.0 (8973)	4.00 (40.8)	3800	0.160	34.1	4.5



**ROTARY
CYLINDER**

High Speed Hydraulic Cylinder with Open Centre

F series

KITAGAWA standard thru-hole type

- Built-in check valve and relief valve
- * CE correspondence (Only series with checking device)

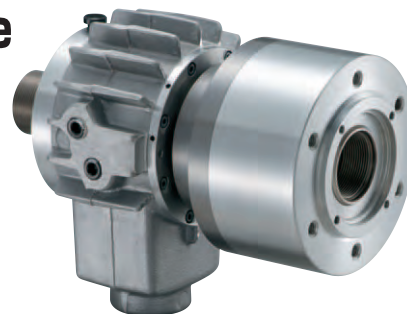

Dimensional Drawings

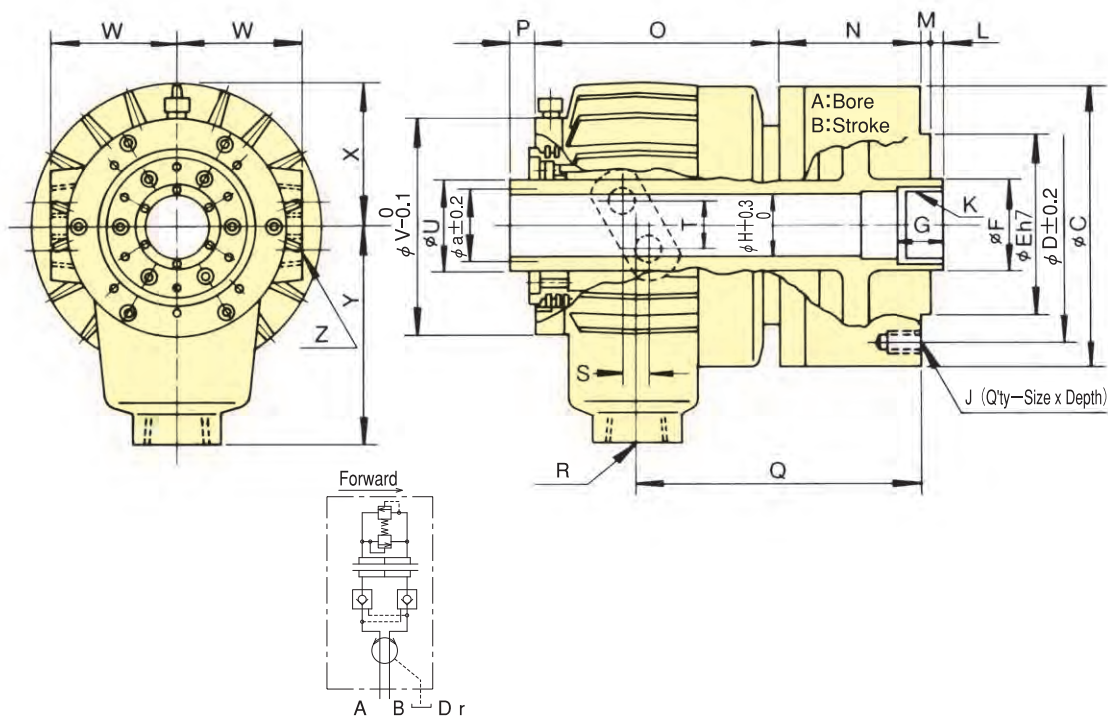

Dimensions

Dimensions Model	A	B	C	D	E (h7)	F	G	H	J	K	L max.	L min.	M	N	O	P max.	P min.	Q	R	S	T	U	V	W	X	Y	Z	a
F0933H	95	12	125	100	80	45	25	33.5	6-M 8x15	M 38x1.5	+7	-5	5	71	119	41	29	142	RC ³ / ₄	11.8	22	M39x1.5	104	64	66	110	2x2-RC ¹ / ₄	-
F2511H	250	23	310	275	230	140	45	117.5	12-M 16x32	M 130x2.0	+18	-5	6	101	209	38	15	217	RC 1	27	20	134.6	232	125	135.5	215	2x2-PT ³ / ₈	127

Specifications

*Total leakage : Pressure 3.00MPa (30.6kgf/cm²) and oil temperature 50°C. *Draw bar pull force : Pressure 4.00MPa (40.8kgf/cm²)

Specifications Model	Thru-Hole mm	Piston stroke mm	Piston Area		Draw bar		Max. Operation Pressure MPa (kgf/cm ²)	Total leakage ℓ /min	Max. Speed min ⁻¹	Net Weight kg	Moment of inertia kg·m ²
			Push Side cm ²	Pull Side cm ²	Push Side kN(kgf)	Pull Side kN(kgf)					
F0933H	33	12	58	55	22.0 (2243)	20.6 (2100)	4.00 (40.8)	3.0	8000	8.5	0.008
F2511H	117.5	23	348	336	125.0 (12746)	120.0 (12236)	4.00 (40.8)	7.0	2800	60.0	0.455

Cylinder



**ROTARY
CYLINDER**

Coolant Collector Confirmation Device

Dimensional Drawings

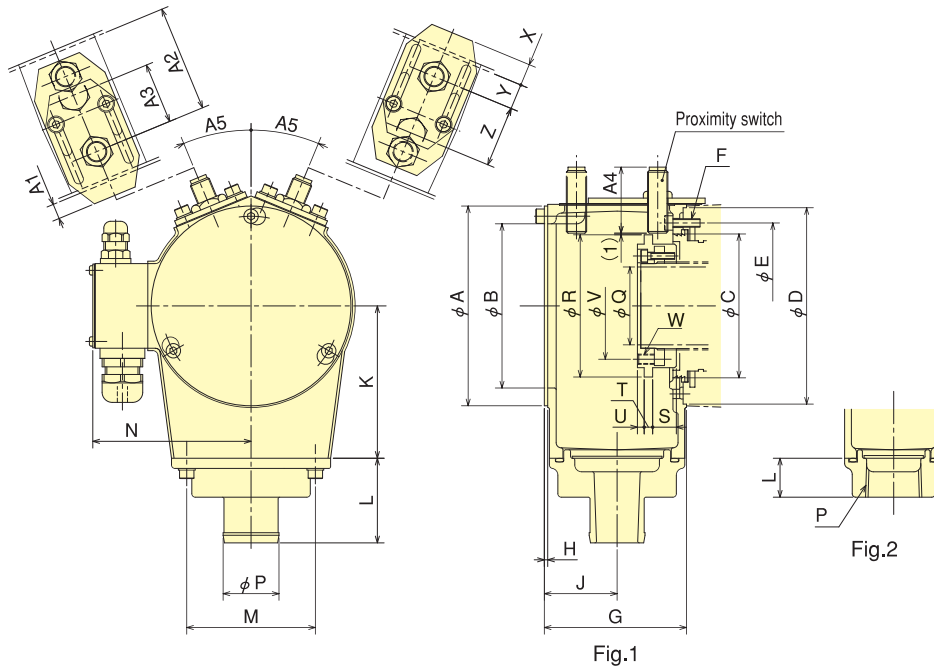

Proximity Switch Type 1
manufactured by B & Plus KK
BES516-329-E3R

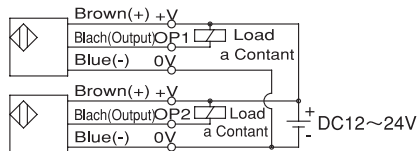

Circuit Diagram for Proximity Switch Output
NPN A Contact (Normally open)

Proximity Switch Type 2
manufactured by Yamatake
FL7M-3J6HD

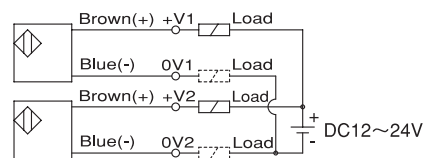

Circuit Diagram for Proximity Switch Output
DC two-wire system A Contact (Normally open)
Lead = Both sides connectable

Dimensions

*The under bodies of CSK12Y2A, CSK14Y2A, CSK16Y2A, CSK17Y2A, CSK18Y2A, CSK21Y2A, and CS-25HW are based on Fig. 2.

Model	Cylinder	A	B	C	D	E	F	G	H	J	K	L	M	N	P	Q
CS-S10BN	S1036	118	97	73	104	88	4-M5	84	2	43	90	50	76	93.5	33	36
CS-S12BN	S1246	118	97	85	116	98	4-M5	84	2	43	90	50	76	93.5	33	46
CS-S15BN	S1552	136	114	96	135	110	4-M6	84	2	43	100	50	76	103.5	33	52
CS-S18BN	S1875	181	154	121	164	155	4-M6	88	2	46	140	50	76	126.5	33	75
CS-S20BN	S2091	181	154	138	180	165	4-M6	104	2	44	140	50	76	126.5	33	91
CSK12Y2A	SS1246K	118	97	85	116	98	4-M5	62	2	32	90	23	76	92.5	Rc 1	46
CSK14Y2A	SS1453K	136	114	96	135	110	4-M6	84	2	35	100	23	76	102.5	Rc 1	53
CSK16Y2A	SS1666K	171	144	111	154	145	4-M6	88	2	38	135	23	76	121.5	Rc 1	66
CSK17Y2A	SS1775K	181	154	121	164	155	4-M6	71	2	37.5	140	23	76	123.5	Rc 1	75
CSK18Y2A	SS1881K	191	165	126	175	166	4-M6	88	2	38	145	23	76	130.5	Rc 1	81
CSK21Y2A	SS2110K	229	200	160	210	201	4-M6	84	2	35	163	23	76	150.5	Rc 1	106
CS-F08BN	F0933H	118	97	73	104	88	4-M5	84	2	43	90	50	76	93.5	26	33
CS-25HW	F2511H	232	200	179	-	206	4-M6	101.6	1.6	51.6	180	-	76	148.5	Rc3/4	117.5

Model	Cylinder	R	S	T	U	V	W	X _{max.}	Y	Z	A1 _{max.}	A2	A3	A4	A5	Proximity switch
CS-S10BN	S1036	84	14	5	4	52	4-M6	13	15	36	9	63	36	39	22.5°	TYPE.1
CS-S12BN	S1246	84	14	5	4	63	4-M6	13	15	36	9	63	36	39	22.5°	TYPE.1
CS-S15BN	S1552	99	14	5	4	70	4-M6	13	15	36	9	63	36	39	22.5°	TYPE.1
CS-S18BN	S1875	144	14	5	4	95	4-M6	15	15	39	15	71	39	39	15°	TYPE.1
CS-S20BN	S2091	144	21	5	2	108	4-M6	8	22	41	10	82	41	39	15°	TYPE.1
CSK12Y2A	SS1246K	84	10	5	8	63	4-M6	10	15	27	7	42	27	35	22.5°	TYPE.2
CSK14Y2A	SS1453K	99	4	5	11.5	70	4-M6	13	15	36	10	64	37	35	20°	TYPE.2
CSK16Y2A	SS1666K	134	12.5	5	4	85.5	4-M6	8	15	28	7	70	28	35	15°	TYPE.2
CSK17Y2A	SS1775K	144	14	5	4	95	4-M6	13.5	14.5	32.5	13.5	54.5	32.5	35	15°	TYPE.2
CSK18Y2A	SS1881K	155	12.5	5	4	100	4-M6	8	15	28	7	70	28	35	15°	TYPE.2
CSK21Y2A	SS2110K	190	14	5	4	130	4-M6	13	15	36	9	63	36	35	12°	TYPE.2
CS-F08BN	F0933H	72	25	7	-	-	-	13	15	36	9	63	36	39	22.5°	TYPE.1
CS-25HW	F2511H	192	12	12	-	-	-	18	17	52	11.4	85	36	39	22.5°	TYPE.1



**ROTARY
CYLINDER**

Double piston cylinder YW..R series

Best suited for HW-series chucks

- YW..R Built-in check valve and pressure relief valve
 - YW..RE Built-in check valve, pressure valve and sensor switches
- * CE correspondence (YW-RE)

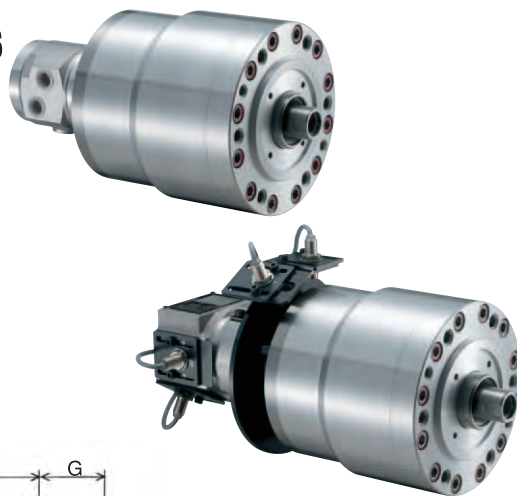

Dimensional Drawings

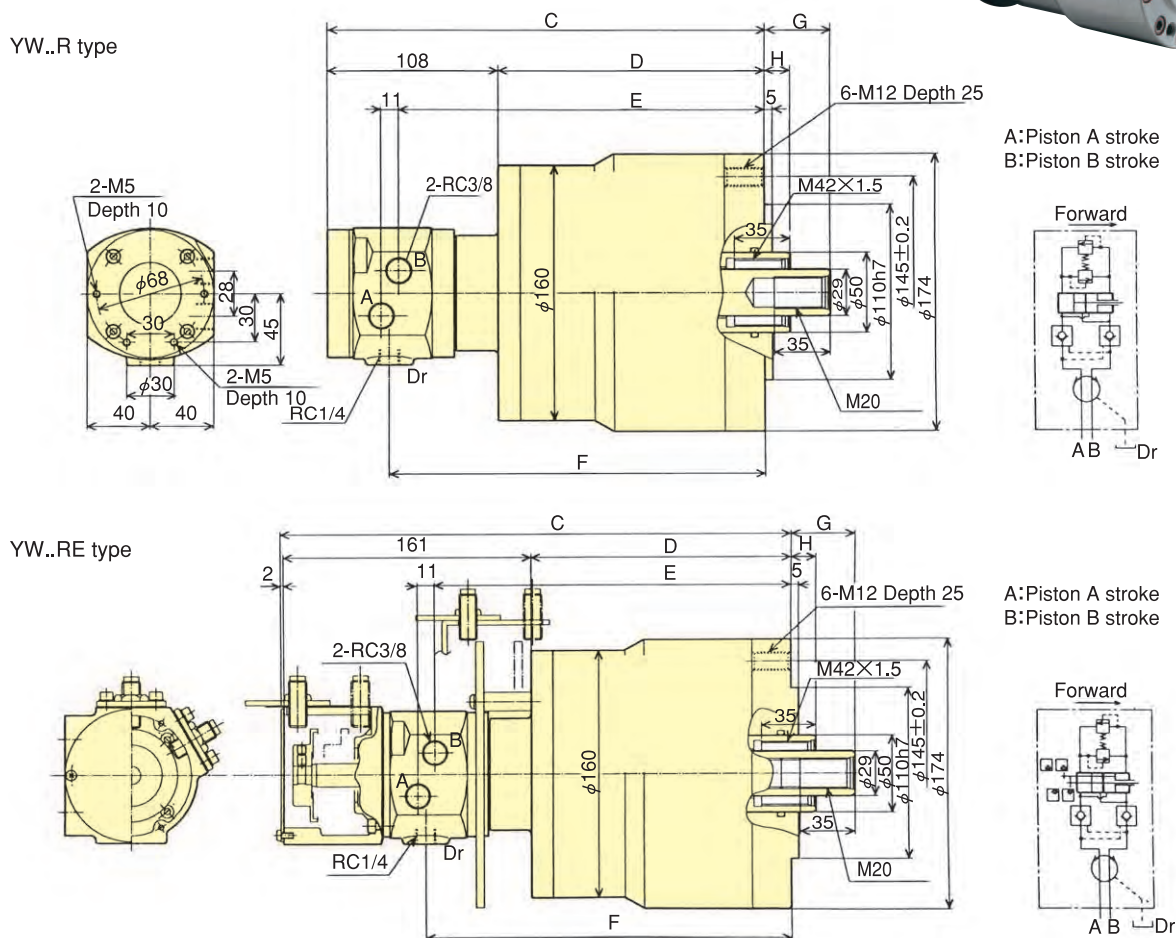

Dimensions

Model	A	B	C	D	E	F	G max.	G min.	H max.	H min.
YW1220R	20	20	276	168	231	237	61	41	36	16
YW1225R	25	25	286	178	241	247	56	31	36	11
YW1220RE	20	20	331	168	231	237	61	41	36	16
YW1225RE	25	25	341	178	241	247	56	31	36	11

Specifications ※ Draw bar pull force : Pressure 3.00MPa (30.6kgf/cm²) ※ Total leakage : 3.00MPa (30.6kgf/cm²) and oil temperature 50°C.

Model	Piston stroke mm	Piston Area		Piston Area		Max. Operation Pressure MPa (kgf/cm ²)	Total leakage ℓ /min	Max. Speed min ⁻¹	Weight kg	Moment of inertia kg·m ²
		Push Side cm ²	Pull Side cm ²	Push Side kN(kgf)	Pull Side kN(kgf)					
YW1220R	20	126	113	33.0(3365)	31.0(3161)	3.00 (30.6)	0.7	5000	15.3	0.043
YW1225R	25	126	113	33.0(3365)	31.0(3161)	3.00 (30.6)	0.7	5000	15.5	0.044
YW1220RE	20	123	113	32.0(3263)	31.0(3161)	3.00 (30.6)	0.7	5000	16.3	0.044
YW1225RE	25	123	113	32.0(3263)	31.0(3161)	3.00 (30.6)	0.7	5000	16.5	0.045



**ROTARY
CYLINDER**

Compact Style Hydraulic Cylinder with Closed Centre

M series

Short, Compact, and Light

The compact design maximises Lathe performance

- Compact and lightweight
- Built-in check valve and pressure relief valve, and sensor switches

*CE correspondence

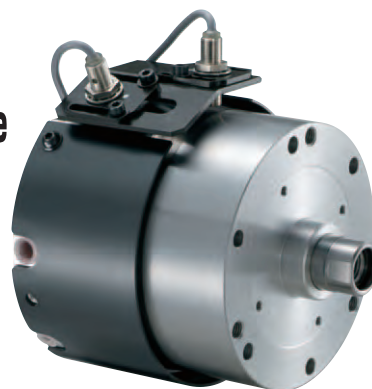

Dimensional Drawings

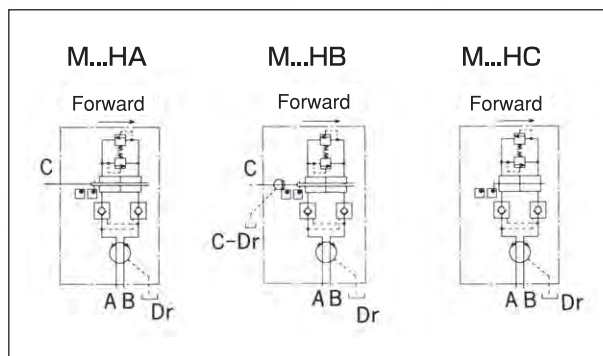
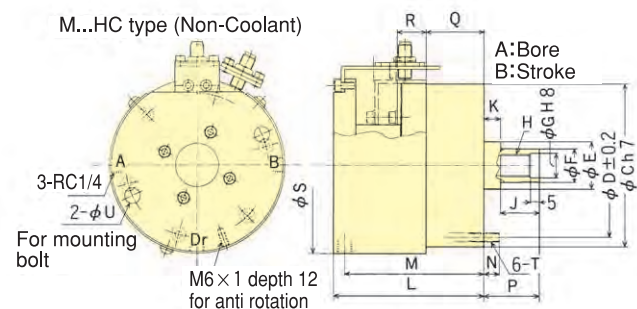
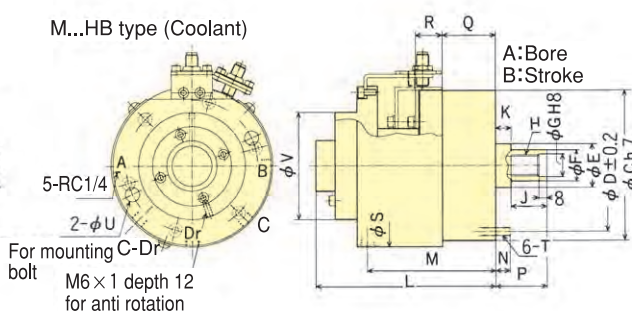
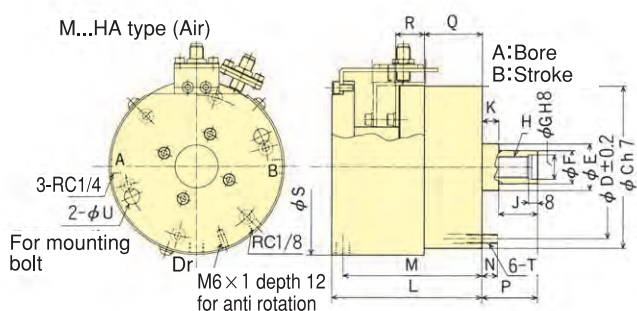

Dimensions

Model	A	B	C (h7)	D	E	F	G (H8)	H	J	K	L	M	N	P max.	P min.	Q max.	Q min.	R	S	T	U	V
M1120HA21N	110	20	145	128	42	30	22	M20	30	15	135	125	14	60	40	72	52	26	159.2	M 8	14	—
M1120HB21N	110	20	145	128	42	30	22	M20	30	15	175	125	14	60	40	72	52	26	159.2	M 8	14	104
M1120HC21N	110	20	145	128	42	30	22	M20	30	15	135	125	14	60	40	72	52	26	159.2	M 8	14	—
M1221HA21N	120	21	168	145	44	32	22	M20	30	15	138	128	14	60	39	75	54	27	182.2	M10	17	—
M1221HB21N	120	21	168	145	44	32	22	M20	30	15	178	128	14	60	39	75	54	27	182.2	M10	17	104
M1221HC21N	120	21	168	145	44	32	22	M20	30	15	138	128	14	60	39	75	54	27	182.2	M10	17	—
M1330HA21N	130	30	168	150	51	36	26	M24	35	15	144	134	18	60	30	79	49	37	182.2	M10	17	—
M1330HB21N	130	30	168	150	51	36	26	M24	35	15	184	134	18	60	30	79	49	37	182.2	M10	17	104
M1330HC21N	130	30	168	150	51	36	26	M24	35	15	144	134	18	60	30	79	49	37	182.2	M10	17	—

Specifications

*Draw bar: Max. Operation Pressure M1120H $\frac{1}{2}$ 3.5MPa (35.7kgf/cm 2), M1221H $\frac{1}{2}$ 4.0MPa (40.8kgf/cm 2), M1330H $\frac{1}{2}$ 4.0MPa (40.8kgf/cm 2)

*Total leakage: Pressure 3.0MPa (30.6kgf/cm 2) and oil temperature 50°C. *Proximity switch: Model BES516-325-E3R (manufactured by B & Plus KK) DC 12/24 V 200mA PNP

Model	Piston stroke mm	Piston Area Push Side cm 2	Piston Area Pull Side cm 2	Draw bar Push Side kN(kgf)	Draw bar Pull Side kN(kgf)	Max. Operation Pressure MPa (kgf/cm 2)	Total leakage ℓ /min	Max. Speed min $^{-1}$	Weight kg	Moment of inertia kg·m 2
M1120HA21N	20	87.6	84	28.0 (2855)	27.0 (2753)	3.50 (35.7)	1.2	6000	8.2	0.016
M1120HB21N	20	87.6	84	28.0 (2855)	27.0 (2753)	3.50 (35.7)	1.2	6000	8.5	0.016
M1120HC21N	20	87.6	84	28.0 (2855)	27.0 (2753)	3.50 (35.7)	1.2	6000	8.2	0.016
M1221HA21N	21	105.7	102	39.0 (3977)	38.0 (3875)	4.00 (40.8)	1.2	6000	10.2	0.028
M1221HB21N	21	105.7	102	39.0 (3977)	38.0 (3875)	4.00 (40.8)	1.2	6000	10.5	0.028
M1221HC21N	21	105.7	102	39.0 (3977)	38.0 (3875)	4.00 (40.8)	1.2	6000	10.2	0.028
M1330HA21N	30	125.3	119	47.0 (4793)	45.0 (4589)	4.00 (40.8)	1.2	6000	10.3	0.029
M1330HB21N	30	125.3	119	47.0 (4793)	45.0 (4589)	4.00 (40.8)	1.2	6000	10.6	0.029
M1330HC21N	30	125.3	119	47.0 (4793)	45.0 (4589)	4.00 (40.8)	1.2	6000	10.3	0.029



**ROTARY
CYLINDER**

Hydraulic Cylinder with Closed Centre Y-R series

Closed Centre KITAGAWA standard type

- Built in safety check valves and pressure relief valves

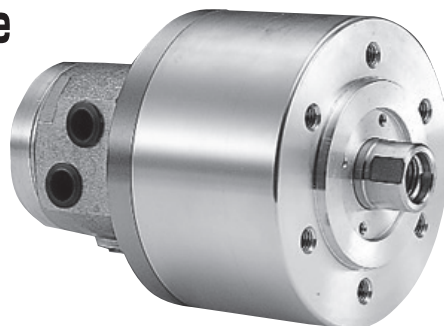

Dimensional Drawings

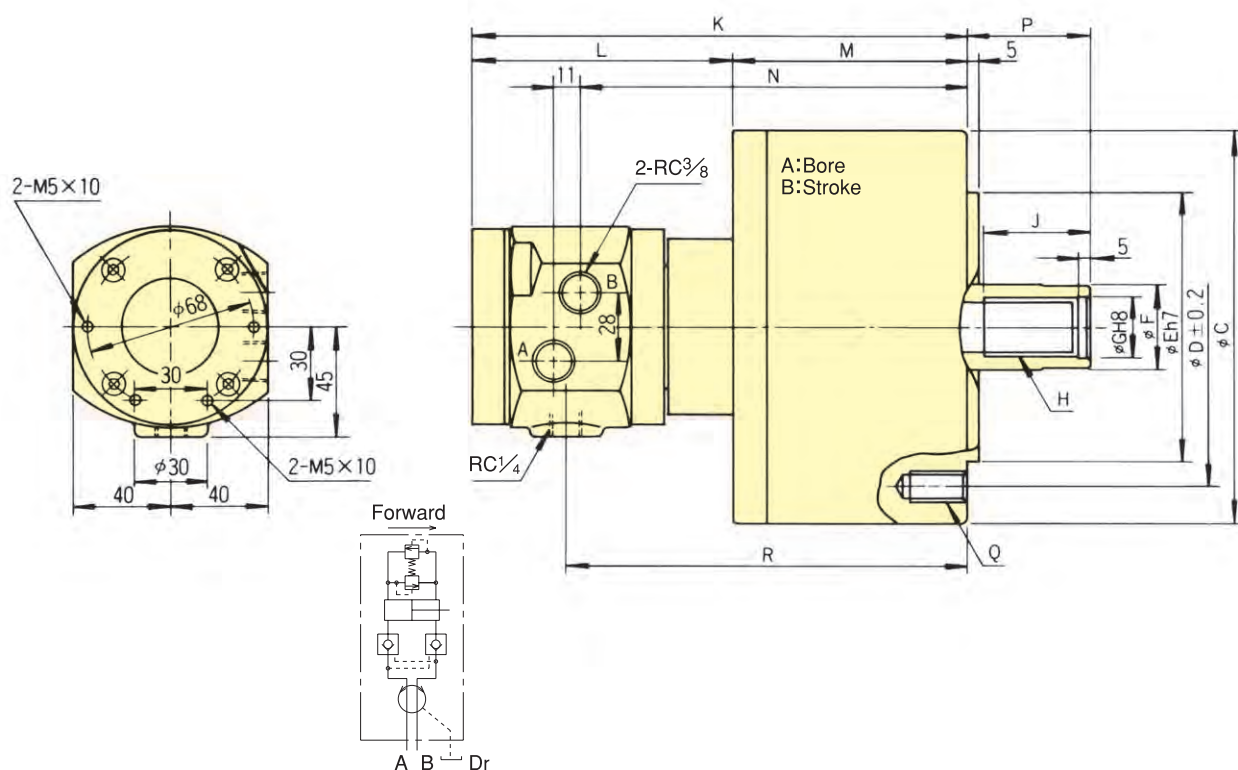

Dimensions

Model	A	B	C	D	E	F	G	H	J	K	L	M	N	P max.	P min.	Q	R
Y0715R	75	15	104	90	65	30	21	M20	35	172	106	66	127	46	31	6-M 6×20	133
Y1020R	105	20	135	100	80	30	21	M20	35	197	108	89	152	45	25	6-M10×20	158
Y1225R	125	25	160	130	110	35	25	M24	44	205	108	97	160	51	26	6-M12×24	166
Y1530R	150	30	190	130	110	45	31	M30	45	214	108	106	169	56	26	12-M12×24	175
Y2035R	200	35	245	145	120	55	37	M36	60	228	106	122	183	69	34	12-M16×30	189

Specifications

*Draw bar pull force : Pressure 4.0MPa (40.8kgf/cm²) *Total leakage : 3.0MPa (30.6kgf/cm²) and oil temperature 50°C.

Model	Piston stroke mm	Piston Area		Draw bar		Max. Operation Pressure MPa (kgf/cm ²)	Total leakage ℓ / min	Max. Speed min ⁻¹	Weight kg	Moment of inertia kg·m ²
		Push Side cm ²	Pull Side cm ²	Push Side kN(kgf)	Pull Side kN(kgf)					
Y0715R	15	44	37	16.6 (1693)	13.9 (1417)	4.00 (40.8)	0.8	6000	4.0	0.003
Y1020R	20	86	79	32.0 (3263)	29.0 (2957)	4.00 (40.8)	0.8	6000	7.1	0.013
Y1225R	25	122	113	46.0 (4691)	42.0 (4283)	4.00 (40.8)	0.8	6000	10.0	0.023
Y1530R	30	176	160	66.0 (6730)	60.0 (6118)	4.00 (40.8)	0.8	5500	13.5	0.048
Y2035R	35	314	290	117.0 (11930)	108.0 (11013)	4.00 (40.8)	0.8	5500	22.0	0.098

Cylinder



**ROTARY
CYLINDER**

Hydraulic Cylinder with Closed Centre Y-RE series

Closed Centre Kitagawa standard series Built in proximity switch

- Built-in check valve, relief valve and sensor switches
- * CE correspondence

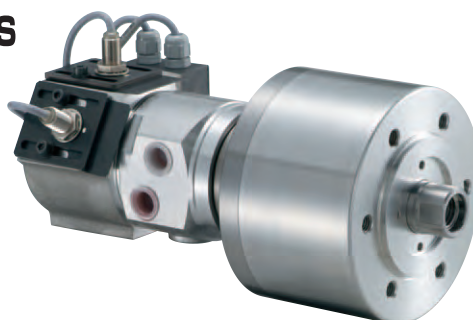

Dimensional Drawings

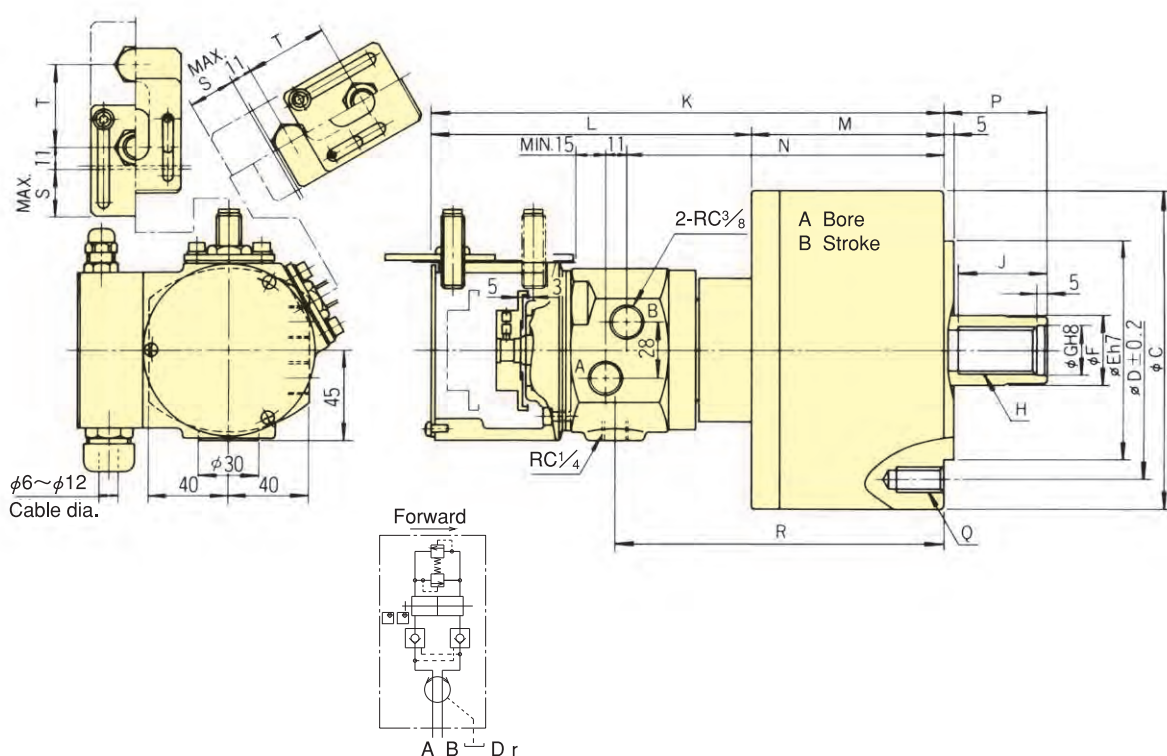

Dimensions

Dimensions	A	B	C	D	E	F	G	H	J	K	L	M	N	P max.	P min.	Q	R	S	T
Y0715RE	75	15	104	90	65	30	21	M20	32	227	161	66	127	46	31	6-M 6×20	133	23	41
Y1020RE	105	20	135	100	80	30	21	M20	35	252	163	89	152	45	25	6-M10×20	158	23	41
Y1225RE	125	25	160	130	110	35	25	M24	44	260	163	97	160	51	26	6-M12×24	166	23	41
Y1530RE	150	30	190	130	110	45	31	M30	45	269	163	106	169	56	26	12-M12×24	175	23	41
Y2035RE	200	35	245	145	120	55	37	M36	60	288	166	122	183	69	34	12-M16×30	189	28	46

※Draw bar pull force : Pressure 4.00MPa (40.8kgf/cm²) ※Total leakage : Pressure 3.00MPa (30.6kgf/cm²) and oil temperature 50°C.

※Proximity switch:Model BES516-329-E3R (manufactured by B & Plus KK) DC12/24V 200mA NPN

Specifications

Model	Piston stroke mm	Piston Area		Draw bar		Max. Operation Pressure MPa (kgf/cm ²)	Total leakage ℓ /min	Max. Speed min ⁻¹	Net Weight kg	Moment of inertia kg·m ²
		Push Side cm ²	Pull Side cm ²	Push Side kN(kgf)	Pull Side kN(kgf)					
Y0715RE	15	42	37	15.9 (1621)	13.9 (1417)	4.00 (40.8)	0.8	6000	4.5	0.003
Y1020RE	20	84	79	31.0 (3161)	29.0 (2957)	4.00 (40.8)	0.8	6000	7.6	0.012
Y1225RE	25	120	113	45.0 (4589)	42.0 (4283)	4.00 (40.8)	0.8	6000	10.5	0.023
Y1530RE	30	174	160	65.0 (6628)	60.0 (6118)	4.00 (40.8)	0.8	5500	14.0	0.048
Y2035RE	35	312	290	117.0 (11930)	108.0 (11013)	4.00 (40.8)	0.8	5500	22.5	0.098



**ROTARY
CYLINDER**

High Speed Air Cylinder with Closed Centre AY-R series

Ideally for extremely thin walled workpieces

- Secure operation even at low thrust
Air cylinder for machining easily deformed thin workpieces



Dimensional Drawings

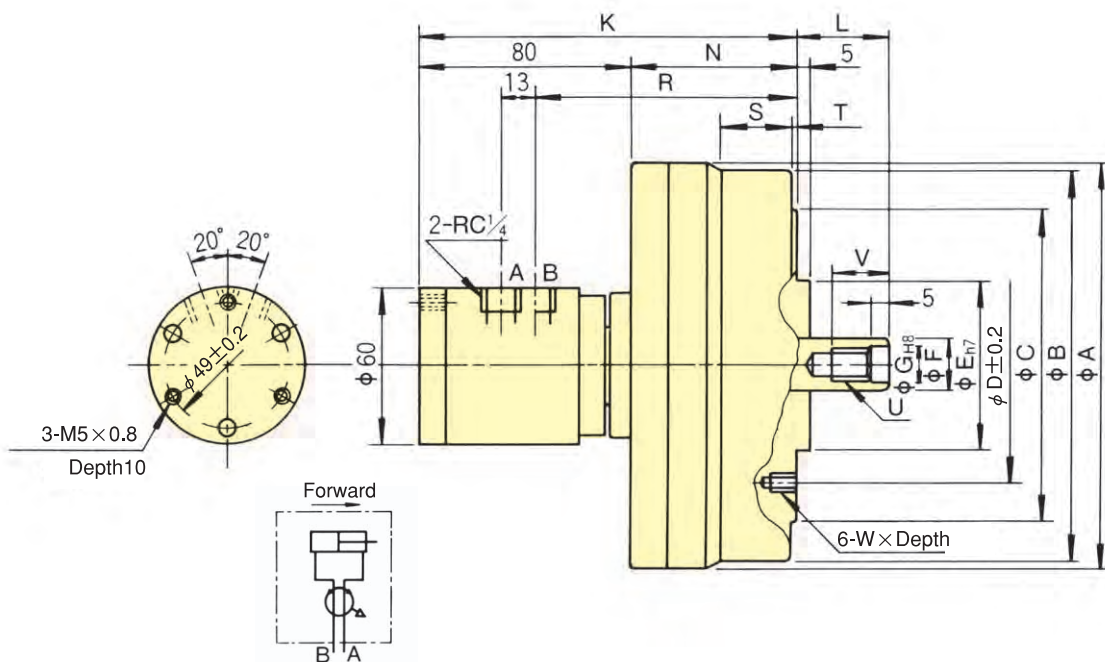

Dimensions

Dimensions	A	B	C	D	E (h7)	F	G (H8)	K	L max.	L min.	N	R	S	T	U	V	W
AY1315R	156	150	120	90	65	20	13	143	35	20	63	99	27	2	M12	22	M 6×10
AY1720R	200	195	140	100	80	25	17	162	65	45	82	118	45	5	M16	30	M10×16
AY2225R	255	245	170	130	110	30	21	173	71	46	93	129	33	5	M20	35	M12×20

Specifications *Draw bar pull force : air pressure 0.5MPa (5.1kgf/cm²) [at efficiency 75%]

Specifications	Piston stroke mm	Piston Area		Draw bar		Max. air pressure MPa (kgf/cm ²)	Max. Speed min ⁻¹	Net Weight kg	Moment of inertia kg·m ²
		Push Side cm ²	Pull Side cm ²	Push Side kN(kgf)	Pull Side kN(kgf)				
AY1315R	15	131	128	4.9 (500)	4.8 (489)	0.8 (8.2)	5000	5.0	0.010
AY1720R	20	227	220	8.5 (867)	8.2 (836)	0.8 (8.2)	5000	8.2	0.028
AY2225R	25	378	371	14.1 (1438)	13.9 (1417)	0.8 (8.2)	4000	9.8	0.080



CHUCK

▶ **P.67~P.73**

Manual Chuck



CHUCK

Scroll Chuck with Integrated Jaw (Straight Recess) SC·JN series

**Durable, reliable and versatile
KITAGAWA'S standard type**

- Straight Recess
- Single Piece Jaw Type
Available with hard jaw for internal and external gripping.
- Steel body
Body is manufactured from high quality steel to increase rigidity, durability and rotational speed.

(SC-3, 4, 5, 14, 16 are made of cast iron,
and JN-6, 7, 9, 10 and 12 are made of steel.)

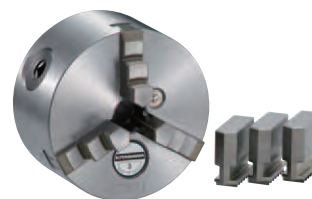
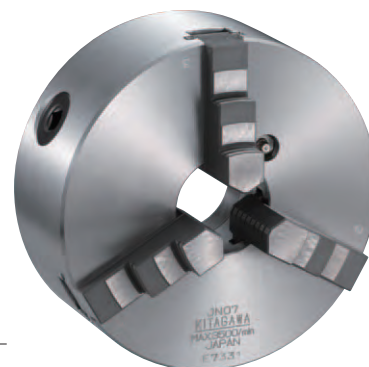
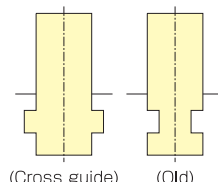

Dimensional Drawings

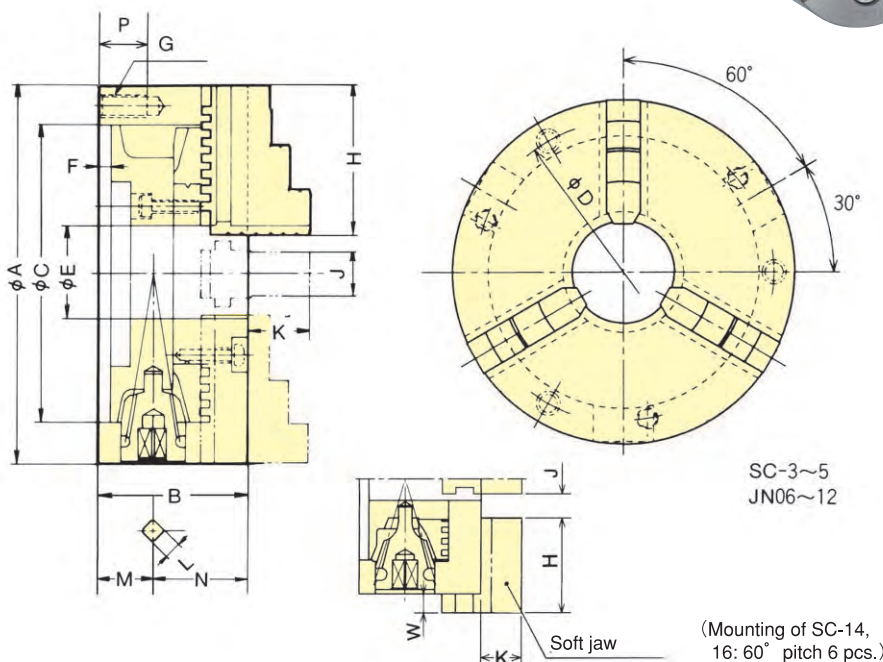

Dimensions

Type	Size	A	B	C (H6)	D	E	F	G	H	J	K	L	M	N	P	W max.	W min.
SC-3(F)		85	45	60	73	16	3.5	3-M 6	35	11	15	7	17	28	13	(1.5)	(- 7)
SC-4(F)		110	58	80	95	24	4.5	3-M 8	42	14	18	8	24.5	33.5	16	(2.5)	(-12)
SC-5(F)		130	60	100	115	32	4.5	3-M 8	50	16	20	8	22.5	37.5	16	(3.5)	(-14.5)
JN06		165	65	130	147	45	5	3-M10	66	20.5	27	10	24	41	20		
JN07		190	75	155	172	55	5	3-M10	78	22.5	31	11	27.5	47.5	20		
JN09		232	84	190	210	70	6	3-M12	88	26.5	33	12	29.5	54.5	23		
JN10		273	86	230	250	85	6	3-M12	98	26.5	37	12	31.5	54.5	23		
JN12		310	96	260	285	96	7	3-M12	113	30.5	44	14	31.5	64.5	25		
SC-14		355	110	300	328	100	7	6-M12	132	35	52	15	38	72	35		
SC-16		405	120	345	375	110	8	6-M12	146	40	58	15	43.5	76.5	35		

Specifications

Type	Spec.	Thru-Hole mm	Max. static gripping force kN(kgf)	Max. speed min ⁻¹	Weight with standard jaws kg	Moment of inertia kg·m ²	Gripping range Outer dia.φmm Inner dia.φmm	Handle torque N·m(kgf·m)
SC-3(F)		16	9.0(918)	2500	1.5	0.001	2~ 70 24~ 64	29.4(3.0)
SC-4(F)		24	12.0(1224)	2500	3.1	0.004	3~ 95 29~ 84	44.1(4.5)
SC-5(F)		32	15.0(1530)	2500	4.4	0.009	3~110 33~100	63.7(6.5)
JN06		45	31.0(3161)	4000	8.4	0.030	3~160 48~150	88.3(9.0)
JN07		55	31.0(3161)	3500	12.2	0.060	4~180 56~170	107.9(11.0)
Type	Spec.	Thru-Hole mm	Max. static gripping force kN(kgf)	Max. speed min ⁻¹	Weight with standard jaws kg	Moment of inertia kg·m ²	Gripping range Outer dia.φmm Inner dia.φmm	Handle torque N·m(kgf·m)
JN09		70	37.0(3773)	2900	21.2	0.160	5~220 62~210	147.0(15.0)
JN10		85	46.0(4691)	2500	28.0	0.253	5~260 70~250	176.5(18.0)
JN12		96	55.0(5608)	2200	41.0	0.588	10~300 86~290	206.0(21.0)
SC-14		100	40.5(4130)	1500	54.0	0.950	25~315 107~290	225.6(23.0)
SC-16		110	45.0(4589)	1500	74.0	1.725	25~360 113~340	245.0(25.0)

※SC type and JN type, each one set of internal jaws and external jaws are attached as standard. Soft jaws cannot be used for JN type. SC-F type, each one set of internal jaws, external jaws and soft jaws are attached as standard. ※When the soft jaws are used for SC-F type, use the chuck of lower specification.

※Since there are types mounted to the front side, please contact your agent if required.



CHUCK

Scroll Chuck with 2 piece Jaw (Straight Recess) JN..T series

Two piece jaw

- Straight Recess
- Cross guide (JN..T series)
Base jaw is located using cross guide reducing runout and distortion.
- Two Piece Jaw Type (with hard jaw and soft jaws)
Top jaw can be changed according to application (i.e. hard jaw suitable for heavy cutting, and soft jaw suitable for precisely machining. Each jaw can also be changed easily. Especially, the hard jaw can clamp inner diameter and outer diameter of work.
- Steel body
Body is manufactured from high quality steel to increase rigidity, durability and rotational speed.

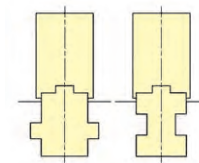

(Cross guide) (Old)

Dimensional Drawings

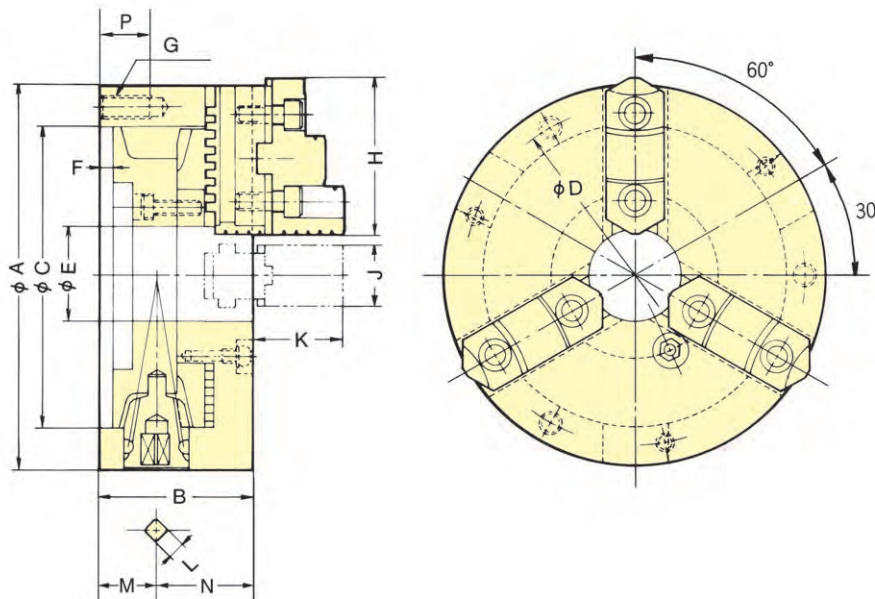

Dimensions

Type	Size	A	B	C (H6)	D	E	F	G	H	J	K	L	M	N	P
JN06T	165	65	130	147	45	5	3-M10	68	26	39	10	24	41	20	
JN07T	190	75	155	172	55	5	3-M10	80	28	42	11	27.5	47.5	20	
JN09T	232	84	190	210	70	6	3-M12	90	32	50	12	29.5	54.5	23	
JN10T	273	86	230	250	85	6	3-M12	100	35	54	12	31.5	54.5	23	
JN12T	310	96	260	285	96	7	3-M12	115	40	56	14	31.5	64.5	25	

Specifications

Type	Spec.	Thru-Hole mm	Max. static gripping force kN(kgf)	Max. speed min ⁻¹	Weight (with standard jaws) kg	Gripping range kg·m ²	Gripping range		Matching soft jaw (hard jaw)	Handle torque N·m(kgf·m)
							Outer dia. φ mm	Inner dia. φ mm		
JN06T	45	31.0(3161)	31.0(3161)	4000	9.0	0.033	3~160	55~150	SBS06(HBS06C)	88.3(9.0)
JN07T	55	31.0(3161)	31.0(3161)	3500	13.0	0.063	4~180	62~170	SBS07(HBS07C)	107.9(11.0)
JN09T	70	37.0(3773)	37.0(3773)	2900	22.0	0.163	5~220	70~210	SBS09(HBS09C)	147.0(15.0)
JN10T	85	46.0(4691)	46.0(4691)	2500	29.0	0.265	5~260	80~250	SBS10(HBS10C)	176.5(18.0)
JN12T	96	55.0(5608)	55.0(5608)	2200	43.0	0.588	10~300	90~290	SBS12(HBS12C)	206.0(21.0)

※For dimensions of soft jaws and hard jaws, refer to pages 93 and 94 on the catalogue.
Since there are types mounted to the front side, please contact your agent if required.



CHUCK

Scroll Chuck with Two Piece Jaw JN..RA series

Two piece jaw

- Short taper

Direct mount to short taper without the need for separate adaptor.

- Soft jaw (option)

Supplied with standard hard jaws (fitted). Soft jaw can also be used. (Option, used together with JN-T type)



Dimensional Drawings

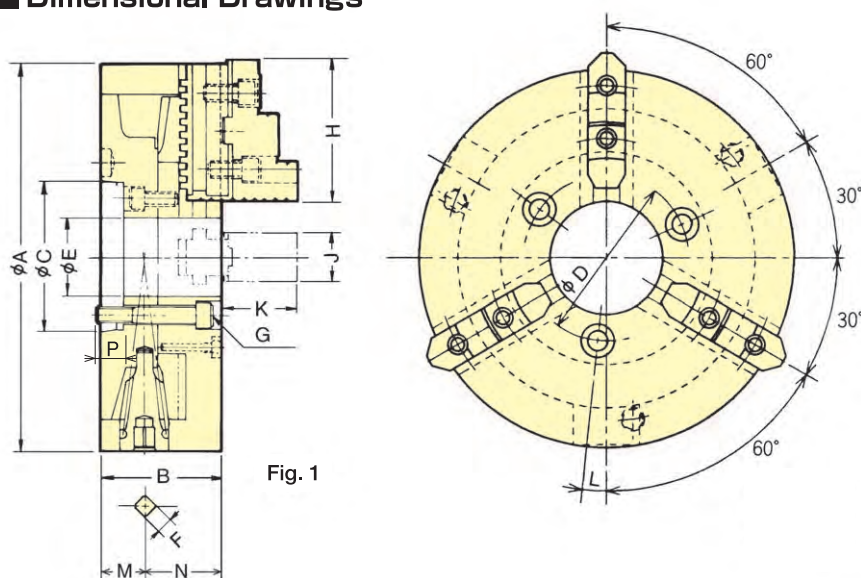
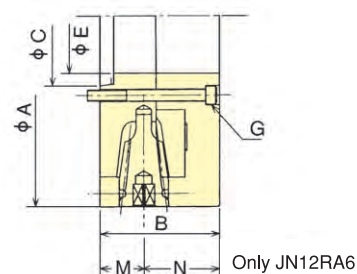

Fig. 1

Fig. 2



Only JN12RA6

Dimensions

Type	Size	A	B	C	D	E	F	G	H	J	K	L	M	N	P
JN06RA5		165	65.5	82.563	61.9	40	10	3-M10	68	26	39	6°	24	41	16
JN07RA5		190	75	82.563	61.9	40	11	3-M10	80	28	42	5°	27.5	47.5	16.5
JN08RA6		210	75	106.375	82.6	59	11	3-M12	80	28	42	6°	29	46	15.5
JN09RA6		232	84	106.375	82.6	59	12	3-M12	90	32	50	6°	29.5	54.5	16.5
JN10RA6		273	86	106.375	82.6	59	12	3-M12	100	35	54	0°	31.5	54.5	14.5
JN10RA8		273	86	139.719	111.1	78	12	3-M16	100	35	54	15°	31.5	54.5	18.5
JN12RA6		310	96	106.375	133.4	96	14	3-M12	115	40	56	0°	31.5	64.5	18.5
JN12RA8		310	96	139.719	111.1	78	14	3-M16	115	40	56	0°	31.5	64.5	23.5

Specifications

Type	Spec.	Thru-Hole mm	Max. static gripping force kN(kgf)	Max. speed min ⁻¹	Weight kg	Moment of inertia kg·m ²	Gripping range		Matching hard jaw	Handle torque N·m(kgf·m)
							Outer dia. φmm	Inner dia. φmm		
JN06RA5		40	31.0(3161)	4000	9.3	0.035	3~160	55~150	HBS06C	88.3(9.0)
JN07RA5		40	31.0(3161)	3500	13.4	0.068	4~180	62~170	HBS07C	107.9(11.0)
JN08RA6		59	31.0(3161)	3200	18.0	0.103	4~200	62~190	HBS07C	107.9(11.0)
JN09RA6		59	37.0(3773)	2900	23.5	0.170	5~220	70~210	HBS09C	147.0(15.0)
JN10RA6		59	46.0(4691)	2500	30.5	0.275	5~260	80~250	HBS10C	176.5(18.0)
JN10RA8		78	46.0(4691)	2500	31.0	0.280	5~260	80~250	HBS10C	176.5(18.0)
JN12RA6		96	55.0(5608)	2200	44.0	0.595	10~300	90~290	HBS12C	206.0(21.0)
JN12RA8		78	55.0(5608)	2200	45.0	0.608	10~300	90~290	HBS12C	206.0(21.0)



CHUCK

2-Jaw Scroll Chuck

JT series

This two jaw chuck provides the optimum solution for gripping valves, pipe joints and other irregularly shaped components

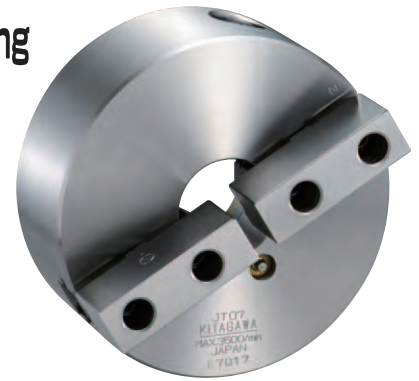

- Straight recess
Mounting dimensions are the same as the JN type.

Dimensional Drawings

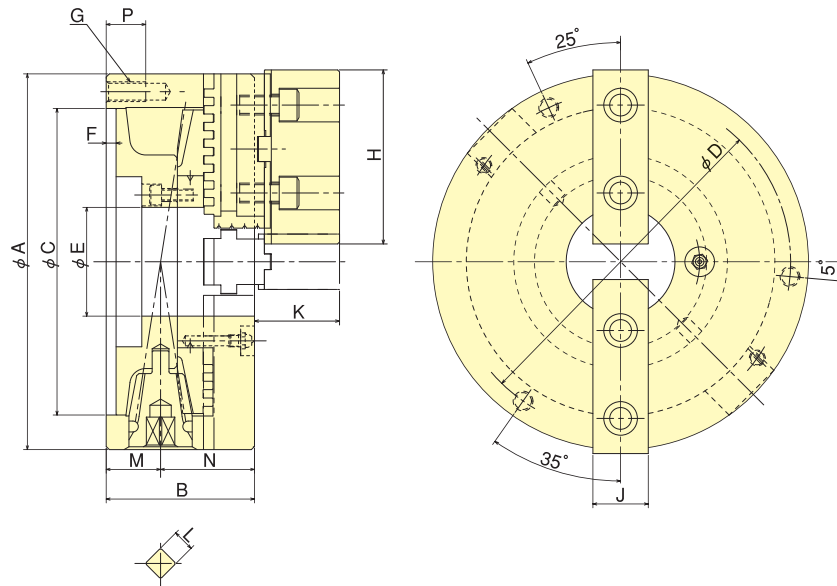

Dimensions

Type	Size	A	B	C Size	C Tolerance	D Size	D Tolerance	E	F	G	H	J	K	L Size	L Tolerance	M	N	P
JT07		190	75	155	$^{+0.025}_0$	172	± 0.2	55	5	3-M10	88	28	43	11	$^{+0.15}_{+0.06}$	27.5	47.5	20
JT09		232	84	190	$^{+0.029}_0$	210	± 0.2	70	6	3-M12	100	32	50	12	$^{+0.15}_{+0.06}$	29.5	54.5	23

Specifications

Type	Spec.	Thru-Hole mm	Max. static gripping force kN(kgf)	Max. speed min ⁻¹	Weight (with standard jaws) kg	Moment of inertia kg·m ²	Gripping range		Matching soft jaw	Handle torque N·m(kgf·m)
							Outer dia.φmm	Inner dia.φmm		
JT07		55	20.7(2110)	3500	12.6	0.065	4~180	62~170	For JT07	73.5 (7.5)
JT09		70	24.7(2518)	2900	21.4	0.160	5~220	70~210	For JT09	98.0 (10.0)



CHUCK

4-Jaw Scroll Chuck

JS series

Reliable and effective gripping of irregularly shaped components

- Thin walled materials ensure minimal distortion, even with thin-walled cylindrical pipe
- Straight recess
Mounting dimensions are the same as the JN type.



Dimensional Drawings

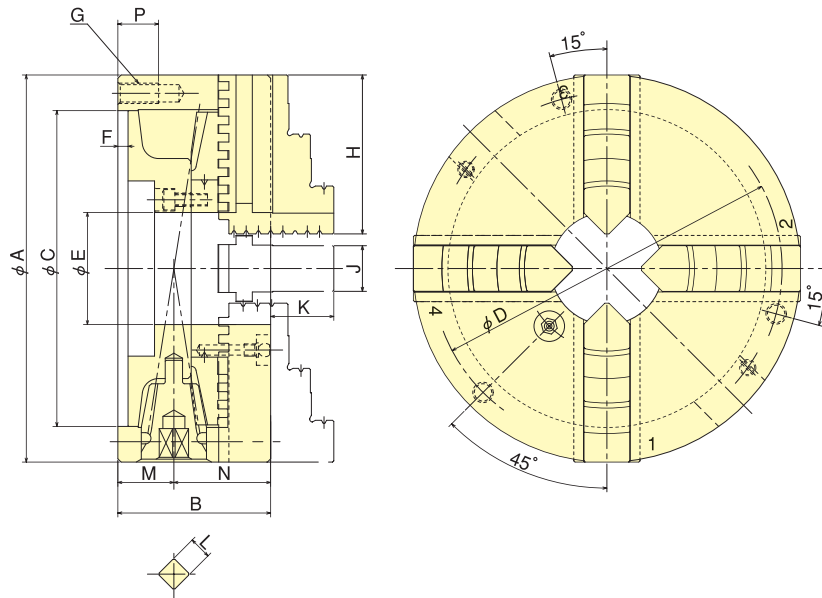

Dimensions

Type	Size	A	B	C Size	C Tolerance	D Size	D Tolerance	E	F	G	H	J	K	L Size	L Tolerance	M	N	P
JS07	190	75	155	$+0.025_0$	172	± 0.2	55	5	3-M10	78	22.4	31	11	$+0.15_{+0.05}$	27.5	47.5	20	
JS09	232	84	190	$+0.029_0$	210	± 0.2	70	6	3-M12	88	26.4	33	12	$+0.15_{+0.05}$	29.5	54.5	23	

Specifications

Type	Spec.	Thru-Hole mm	Max. static gripping force kN(kgf)	Max. speed min ⁻¹	Weight kg	Moment of inertia kg·m ²	Gripping range		Handle torque N·m(kgf·m)
							Outer dia. φ mm	Inner dia. φ mm	
JS07		55	31.0(3161)	3500	12.5	0.063	4~180	56~170	107.9(11.0)
JS09		70	37.0(3773)	2900	21.5	0.163	5~220	62~210	147.0(15.0)



CHUCK

Independent Chuck (Straight Recess)

IC series

Independent 4 Jaw Chuck

● Straight recess



Dimensional Drawings

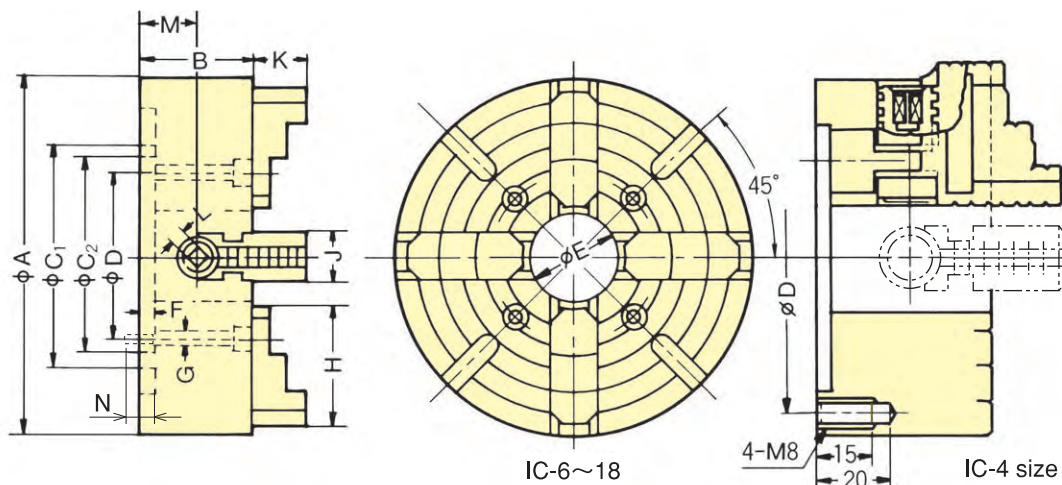

(Note) In IC-4, 6 and 8, there is no T-groove on the chuck surface.

Dimensions

Type	Size	A	B	C ₁	Size	Tolerance	D	E	F	G	H	J	K	Size	L	Tolerance	M	N
	IC-4	IC-6	IC-8	IC-10	IC-12									IC-14				
IC-4	100	48	-	75H7	+0.030	86	30	4	-	40	18	20	6	+	26	-		
IC-6	150	60	-	130H7	0	115	40	5	4-M10	55	25	25	8	+	33	16		
IC-8	200	75	-	175H7	+0.040	155	50	6	4-M12	75	30	30	10	+	43.5	20		
IC-10	250	80	165	150H7	0	125	55	6	4-M12	90	30	35	10	+	47.5	21		
IC-12	300	90	186	170H7	0	140	65	6	4-M12	100	35	40	12	+	53	21		
IC-14	350	90	210	190H7	+0.046	160	75	8	4-M12	110	35	45	12	+	53	18		
IC-16	400	100	230	210H7	0	180	90	8	4-M16	120	40	50	14	+	58.5	24		
IC-18	450	105	250	230H7	0	200	100	8	4-M16	130	40	55	14	+	63.5	24		

Specifications

Type	Spec. Thru-Hole mm	Max. static gripping force		Max gripping dia.		Min. gripping dia. Inner jaw ϕ mm	Chuck		
		Handle torque N·m (kgf·m)	Tightening force of a jaw kN (kgf)	Inner jaw ϕ mm	Outer jaw ϕ mm		Weight kg	Moment of inertia kg·m ²	Max. speed min ⁻¹
IC-4	30	34.0 (3.5)	5.0 (510)	40	90	8	2.4	0.003	2000
IC-6	40	49.0 (5.0)	6.0 (612)	60	140	8	6.1	0.020	1600
IC-8	50	83.0 (8.5)	10.0 (1020)	75	185	14	14.8	0.075	1600
IC-10	55	118.0 (12.0)	14.0 (1428)	95	220	14	21.0	0.150	1600
IC-12	65	147.0 (15.0)	16.0 (1632)	125	265	18	29.5	0.350	1400
IC-14	75	157.0 (16.0)	17.0 (1733)	155	310	20	40.0	0.725	1400
IC-16	90	216.0 (22.0)	20.0 (2039)	190	360	30	56.5	1.125	1200
IC-18	100	216.0 (22.0)	20.0 (2039)	220	405	35	70.0	1.750	1200

※T-slot for jig mounting is provided from IC-10 or more.

※Four mounting bolts are provided. (Except IC-4, chucks are mounted with hexagon socket set screws. Consequently, tap the backplate.)

※One hex wrench is attached for the chuck of each size (except IC-4).



CHUCK

Independent Chuck (Short Taper)

IA series

Independent 4 Jaw Chuck

- Chuck for short taper that can be directly mounted without back plate



Dimensional Drawings

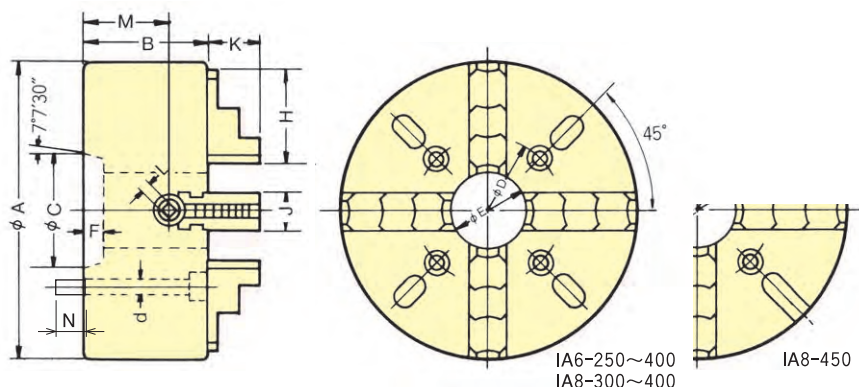

IA6-250~400
IA8-300~400

IA8-450

Dimensions

Spindle nose	Type	Size	Dimensions (mm)												(Mounting bolt)	Number of mounting bolts
			A	B	C	D	E	F	H	J	K	L	M	N		
A ₂ - 5	IA 5 -200	200	70	82.563	104.8	50	15	75	30	30	10	38.5	17	M10×75	4	
	IA 6 -250	250	77	106.375	133.4	55	17	90	30	35	10	44.5	17	M12×80	4	
	IA 6 -300	300	90	106.375	133.4	65	17	100	35	40	12	53	19	M12×95	4	
A ₂ - 6	IA 6 -350	350	90	106.375	133.4	75	17	110	35	45	12	53	19	M12×95	4	
	IA 6 -400	400	100	106.375	133.4	75	17	120	40	50	14	58.5	17	M12×100	4	
	IA 6 -450	450	105	106.375	133.4	80	17	130	40	55	14	63.5	20	M12×110	8	
	IA 8 -300	300	100	139.719	171.4	75	18.5	120	40	50	14	58.5	24	M16×105	4	
A ₂ - 8	IA 8 -350	350	100	139.719	171.4	75	18.5	120	40	50	14	58.5	24	M16×105	4	
	IA 8 -400	400	105	139.719	171.4	90	18.5	120	40	50	14	58.5	24	M16×110	4	
	IA 8 -450	450	105	139.719	171.4	100	18.5	130	40	55	14	63.5	24	M16×110	4	

Specifications ※Mounting of IA-6-450 : 45° pitch, 8 pcs.

Spindle nose	Type	Spec.	Thru-Hole mm	Max. static gripping force		Max gripping dia.		Min. gripping dia.		Chuck		
				Handle torque N·m(kgf·m)	Tightening force of a jaw kN(kgf)	Inner jaw φmm	Outer jaw φmm	Inner jaw φmm	Weight kg	Moment of inertia kg·m ²	Max. speed min ⁻¹	
A ₂ - 5	IA 5 -200		50	83.0 (8.5)	10.0(1020)	75	185	14	14.9	0.080	3600	
	IA 6 -250		55	118.0(12.0)	15.0(1530)	95	220	14	24.2	0.188	3000	
	IA 6 -300		65	147.0(15.0)	16.0(1632)	125	265	18	39.1	0.400	2000	
A ₂ - 6	IA 6 -350		75	147.0(15.0)	16.0(1632)	155	310	20	50.9	0.750	2000	
	IA 6 -400		75	216.0(22.0)	20.0(2039)	190	360	30	69.8	1.175	1800	
	IA 6 -450		80	245.0(25.0)	23.0(2345)	220	405	35	97.2	1.775	1200	
	IA 8 -300		75	147.0(15.0)	16.0(1632)	125	265	18	39.1	0.400	2000	
A ₂ - 8	IA 8 -350		75	216.0(22.0)	20.0(2039)	155	310	20	56.2	0.775	2000	
	IA 8 -400		90	245.0(25.0)	23.0(2345)	190	360	30	73.8	1.250	1800	
	IA 8 -450		100	245.0(25.0)	23.0(2345)	220	405	35	102.5	1.825	1200	



**WORK
GRIPPER**

▶ P.75~P.84

Work Gripper



WORK GRIPPER

Work Gripper AS series

Pneumatically operated stationary chuck Can be used as an alternative to a fixture

- Small and lightweight design, with inbuilt air cylinder
- Easy mounting by air piping
- Hollow structure optimal for bar workpiece and air blow
- Standard Soft Jaw for Power Chuck is used
- Lock valve unit ensures constant and regular gripping force in all machining conditions

* CE correspondence

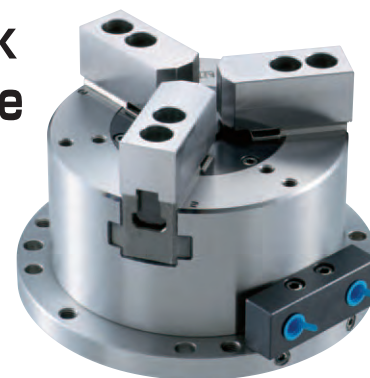

Dimensional Drawings

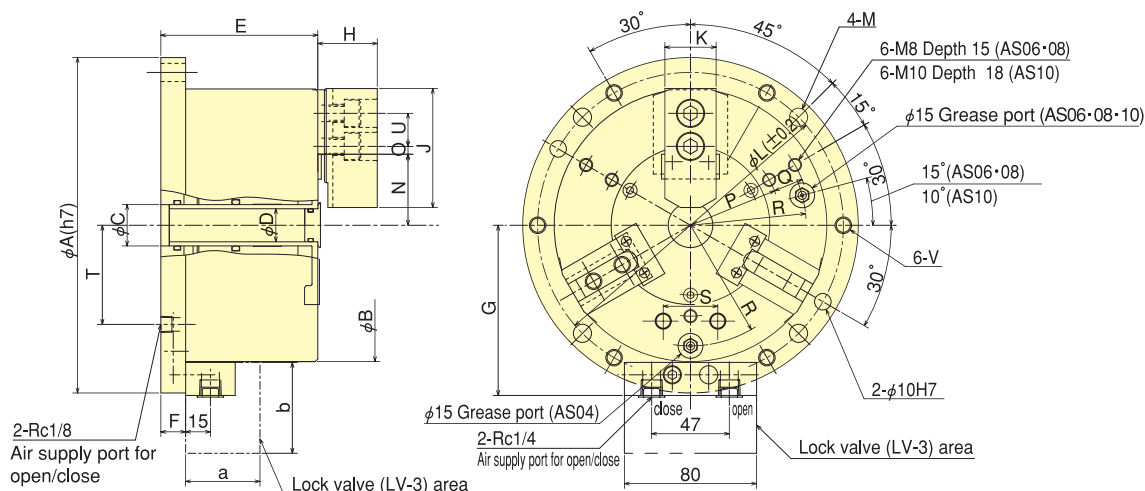

Dimensions

*The dimensions of a/b marked are the size of LV-3(Lock-valve).

Model	Dimensions	ϕA (h7)	ϕB	ϕC (H7)	ϕD	E	F	G	H	J	K	ϕL (± 0.2)	ϕM	N max.	N min.	O max.	O min.	P	Q	R
AS04		148	110	20H7	-	90	15	75.5	27	55	23	130	9	25.5	22.9	9.75	6.75	-	-	43
AS06		203	165	25H7	20	95	15	103	36	72	31	185	11	44.5	41.9	9.25	4.75	55	18	70
AS08		248	210	36H7	30	106	15	125.5	42	95	35	230	11	53	49.85	14.75	8.75	68	25	90
AS10		300	254	50H7	43	110	16	147.5	46	110	40	280	13	66	62.85	16	8.5	85	30	110

Model	Dimensions	S	T	U	V	a	b
AS04		33	34	14	M8	45	55
AS06		33	60.3	20	M10	45	55
AS08		33	80	25	M10	45	55
AS10		33	95	30	M12	45	55

Specifications

*Air Consumption = Under Pressure 0.6MPa Plunger Stroke per 10mm

Model	Specifications	Jaw Stroke (diameter) mm	Gripping force [Pneumatic at 0.6MPa (0.6kgf/cm ²)] kN (kgf)	Weight (kg)	Max. air pressure MPa(kgf/cm ²)	Matching soft jaw	Gripping diameter(mm)		Air consumption (Nℓ)
							Max.	Min.	
AS04		5.2	7.5 (765)	7.3	0.7 (7.0)	SB04B1	110	10	0.40
AS06		5.2	21.0 (2140)	16.0	0.7 (7.0)	SB06B1	165	23	1.04
AS08		6.3	33.0 (3365)	27.7	0.7 (7.0)	SB08B1	210	30	1.81
AS10		6.3	48.0 (4895)	42.5	0.7 (7.0)	SB10A1	254	50	2.52



WORK GRIPPER

Work Gripper (Multi-Plate) AS.M.C series

Multi-plate allows simultaneous machining with up to six grippers on one plate

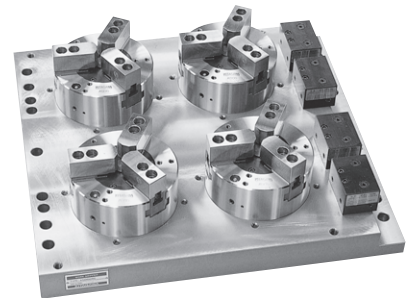

- Lock valve unit (option) can be mounted
- Three jaws (AS type) and two jaws (AT type) can be combined freely

MODEL NUMBER EXPLANATION

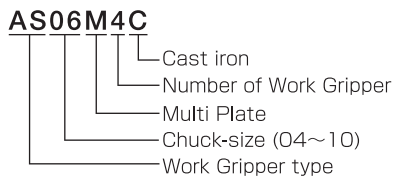

Dimensional Drawings

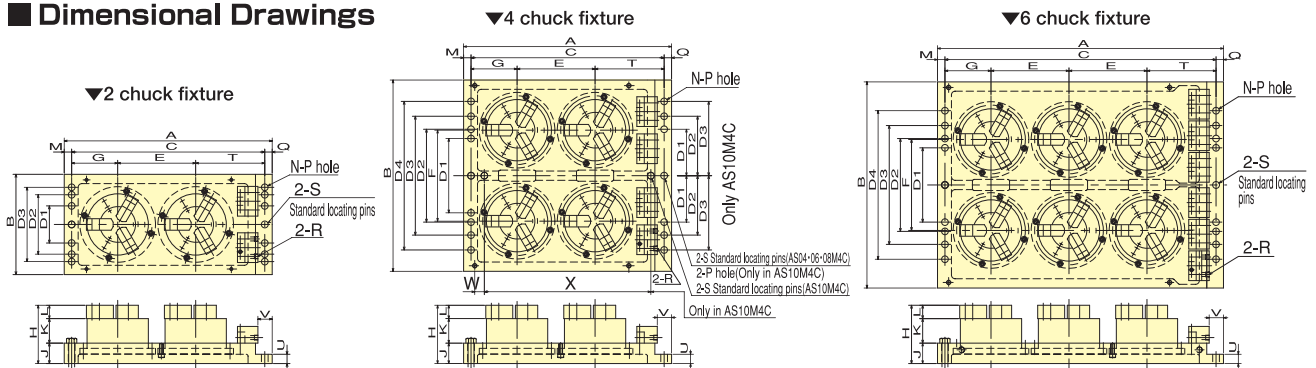

Dimensions

Model	Dimensions spec	Matching Work Gripper	A	B	C	D1	D2	D3	D4	E	F	G	H	J
AS04M2C	2 chuck fixture	AS04	450	205	410	100	160	-	-	155	-	100	143	55
AS06M2C	2 chuck fixture	AS06	560	270	520	100	160	200	-	210	-	124	157	55
AS08M2C	2 chuck fixture	AS08	655	315	615	160	200	250	-	255	-	150	174	55
AS10M2C	2 chuck fixture	AS10	765	375	725	160	200	250	-	310	-	175	182	60
AS04M4C	4 chuck fixture	AS04	450	380	410	160	200	250	320	155	180	100	143	55
AS06M4C	4 chuck fixture	AS06	560	515	520	200	250	320	400	210	245	124	157	55
AS08M4C	4 chuck fixture	AS08	655	600	615	200	250	400	500	255	285	150	174	55
AS10M4C	4 chuck fixture	AS10	765	705	725	160	200	250	-	310	335	175	182	60
AS04M6C	6 chuck fixture	AS04	660	380	620	160	200	250	320	155	180	155	143	55
AS06M6C	6 chuck fixture	AS06	770	555	730	200	250	320	400	210	245	124	157	55

Model	Dimensions	K	L	M	N	φP	Q	R	φS	T	U	V	W	X	Weight (kg)
AS04M2C		61	27	20	8	18	20	Rc1/4	18	155	25	38.5	-	-	17.0
AS06M2C		66	36	20	12	18	20	Rc1/4	18	186	25	38.5	-	-	26.0
AS08M2C		77	42	20	12	18	20	Rc1/4	18	210	25	38.5	-	-	32.0
AS10M2C		76	46	20	12	18	20	Rc1/4	18	240	25	43.5	-	-	50.0
AS04M4C		61	27	20	16	18	20	Rc1/4	18	155	25	38.5	-	-	31.0
AS06M4C		66	36	20	16	18	20	Rc1/4	18	186	25	38.5	-	-	47.0
AS08M4C		77	42	20	16	18	20	Rc1/4	18	210	25	38.5	-	-	58.0
AS10M4C		76	46	20	14	18	20	Rc1/4	18	240	25	43.5	40	645	90.0
AS04M6C		61	27	20	16	18	20	Rc1/4	18	155	25	38.5	-	-	40.0
AS06M6C		66	36	20	16	18	20	Rc1/4	18	186	25	38.5	-	-	67.0



WORK GRIPPER

2-Jaw Work Gripper AT series

Secure gripping of all types of component
Can be used as an alternative to a fixture

- Small and lightweight design, with inbuilt air cylinder
- Easy mounting by air piping
- Hollow structure optimal for bar workpiece and air blow
- Standard Soft Jaw for Power Chuck is used
- Lock valve unit ensures constant and regular gripping force in all machining conditions

* CE correspondence



Dimensional Drawings

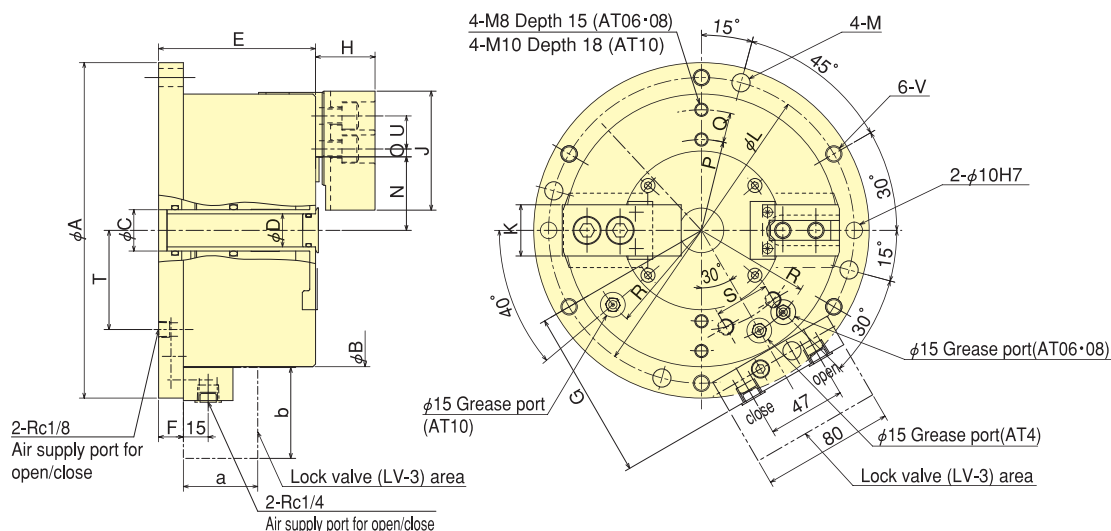

Dimensions

*The dimensions of W/X marked are the size of LV-3(Lock-valve).

Model	Dimensions	φA (h7)	φB	φC	φD	E	F	G	G	H	J	K	φL (±0.2)	φM	N max.	N min.	O max.	O min.	P	Q
AT04		148	110	20H7	-	90	15	75.5 (110.5)		27	55	23	130	9	25.5	22.9	9.75	6.75	-	-
AT06		203	165	25H7	20	95	15	103 (138)		36	72	31	185	11	44.5	41.9	9.25	4.75	55	18
AT08		248	210	36H7	30	106	15	125.5 (160.5)		42	95	35	230	11	53	49.85	14.75	8.75	68	25
AT10		300	254	50H7	43	110	16	147.5 (182.5)		46	110	40	280	13	66	62.85	16	8.5	85	30

Model	Dimensions	R	S	T	U	V	a	b
AT04		43	33	34	14	M8	45	55
AT06		70	33	60	20	M10	45	55
AT08		90	33	80	25	M10	45	55
AT10		110	33	95	30	M12	45	55

Specifications

*Air Consumption = Under Pressure 0.6MPa Plunger Stroke per 10mm

Model	Specifications	Jaw Stroke (diameter) mm	Gripping force [Pneumatic at 0.6MPa (0.6kgf/cm ²)] kN (kgf)	Weight (kg)	Max. air pressure MPa (kgf/cm ²)	Matching soft jaw	Gripping diameter (mm) Max.	Gripping diameter (mm) Min.	Air Consumption (Nℓ)
AT04		5.2	7.5 (765)	6.9	0.6 (6.0)	SB04A1T	110	10	0.40
AT06		5.2	21.0 (2140)	15.0	0.6 (6.0)	SB06A1T	165	23	1.04
AT08		6.3	33.0 (3365)	26.7	0.6 (6.0)	SB08A1T	210	30	1.81
AT10		6.3	48.0 (4895)	40.8	0.6 (6.0)	SB10A1T	254	50	2.52



WORK GRIPPER

2-Jaw Work Gripper (Multi-Plate) ATM.C series

Multi-plate allows simultaneous machining with up to six grippers on one plate

- Lock valve unit (option) can be mounted
- Three jaws (AS type) and two jaws (AT type) can be combined freely

MODEL NUMBER EXPLANATION

AT06M4C

- Cast iron
- Number of Work Gripper
- Multi Plate
- Chuck-size (04~10)
- Work Gripper type

Dimensional Drawings

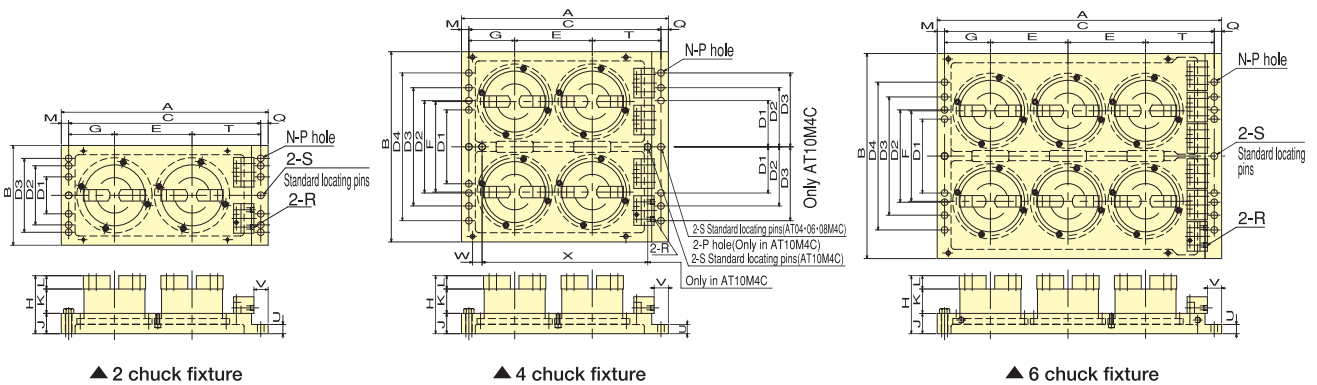

Dimensions

Model	Dimensions		Matching Work Gripper	A	B	C	D1	D2	D3	D4	E	F	G	H	J
	spec														
AT04M2C	2 chuck fixture		AT04	450	205	410	100	160	-	-	155	-	100	143	55
AT06M2C	2 chuck fixture		AT06	560	270	520	100	160	200	-	210	-	124	157	55
AT08M2C	2 chuck fixture		AT08	655	315	615	160	200	250	-	255	-	150	174	55
AT10M2C	2 chuck fixture		AT10	765	375	725	160	200	250	-	310	-	175	182	60
AT04M4C	4 chuck fixture		AT04	450	380	410	160	200	250	320	155	180	100	143	55
AT06M4C	4 chuck fixture		AT06	560	515	520	200	250	320	400	210	245	124	157	55
AT08M4C	4 chuck fixture		AT08	655	600	615	200	250	400	500	255	285	150	174	55
AT10M4C	4 chuck fixture		AT10	765	705	725	160	200	250	-	310	335	175	182	60
AT04M6C	6 chuck fixture		AT04	660	380	620	160	200	250	320	155	180	155	143	55
AT06M6C	6 chuck fixture		AT06	770	555	730	200	250	320	400	210	245	124	157	55

Model	Dimensions													Weight (kg)
	K	L	M	N	φP	Q	R	φS	T	U	V	W	X	
AT04M2C	61	27	20	8	18	20	Rc1/4	18	155	25	38.5	-	-	17.0
AT06M2C	66	36	20	12	18	20	Rc1/4	18	186	25	38.5	-	-	26.0
AT08M2C	77	42	20	12	18	20	Rc1/4	18	210	25	38.5	-	-	32.0
AT10M2C	76	46	20	12	18	20	Rc1/4	18	240	25	43.5	-	-	.050
AT04M4C	61	27	20	16	18	20	Rc1/4	18	155	25	38.5	-	-	31.0
AT06M4C	66	36	20	16	18	20	Rc1/4	18	186	25	38.5	-	-	47.0
AT08M4C	77	42	20	16	18	20	Rc1/4	18	210	25	38.5	-	-	58.0
AT10M4C	76	46	20	14	18	20	Rc1/4	18	240	25	43.5	40	645	90.0
AT04M6C	61	27	20	16	18	20	Rc1/4	18	155	25	38.5	-	-	40.0
AT06M6C	66	36	20	16	18	20	Rc1/4	18	186	25	38.5	-	-	67.0



WORK GRIPPER

Power Wing Work Gripper PWS06

Suitable for 3 to 5-Axis machines
Cost reduction achieved by built-in Cylinder

- Stationary clamping by pull back the workpiece
 Suitable for rough machining, OP-10 or OP-20 with reduced setup time.
- Cost reduction achieved by built-in Cylinder * No need to introduce separated Cylinder for Chuck.
- Available on the standard column of machine * Total height is reduced by built-in Cylinder.
- Available to be mounted on NC Rotary Table



Dimensional Drawings

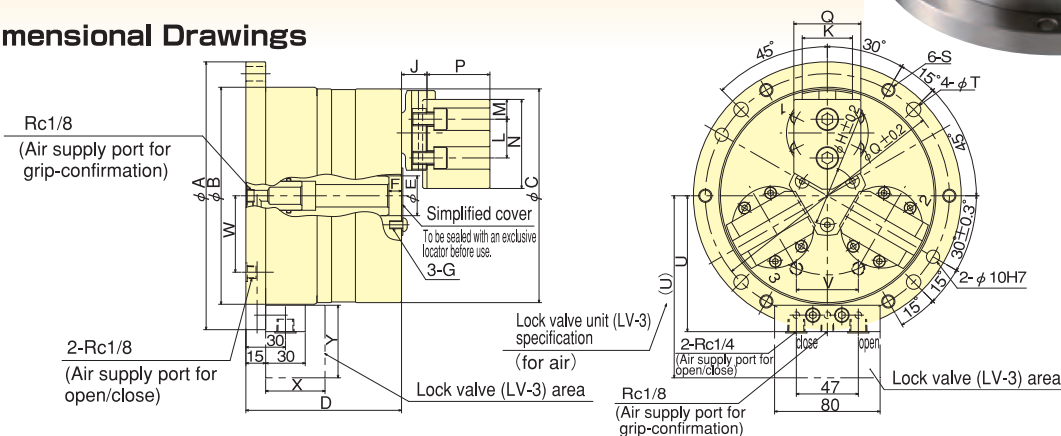

Dimensions

*The dimensions of (U)/X/Y marked are the size of LV-3(Lock-valve).

Dimensions	A	B	C	D	E	F	G	H	J	K	L	M	N	P	Q	R	S	T	U	(U)	V	W	X	Y
Model	h7				+0.02 0	min	M6 Depth 1.2																	
PWS06	203	164.5	162	118	30.17	3.5		44	19.3	38.07	29.36	15	67.5	47.7	50.8	185	M10	11	103	138	47	60	45	55

Specifications

*Clamping force varies in clamping state for jaws and workpiece. *Air Consumption = Under Pressure 0.6MPa Plunger Stroke per 10mm

Dimensions	Plunger stroke mm	Jaw stroke (diameter) mm	Gripping force kN (kgf)		Max. allowable pressure MPa (kgf/cm ²)		Min. allowable pressure MPa (kgf/cm ²)	Gripping diameter mm				Mass (with Standard Soft Jaw) kg	Air Consumption (Nℓ)
			Pneumatic at 0.6MPa (6kgf/cm ²)	Hydraulic at 1.3MPa (13kgf/cm ²)	Pneumatic	Hydraulic		Outer dia. φ	Inner dia. φ	Max.	Min.		
Model								Max.	Min.	Max.	Min.		
PWS06	11.1	7.7	19 (1937)	53 (5404)	0.7 (7)	1.3 (13)	0.2 (2)	120	12.7	152	70	24	0.54

Dimensional Drawing for actuated position (External Gripping)

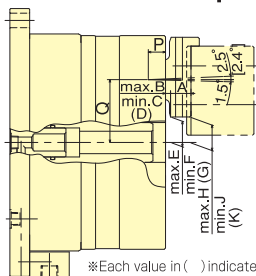

*Each value in () indicate that surface of chuck and Jaw mounting side is parallel.

Dimensions for actuated position (External Gripping)

Dimensions	A	B	C	D	E	F	G	H	J	K
Model										
PWS06	15.50	4.96	3.05	3.80	20.06	18.89	19.33	20.70	18.48	19.33

Dimensional Drawing for actuated position (Internal Gripping)

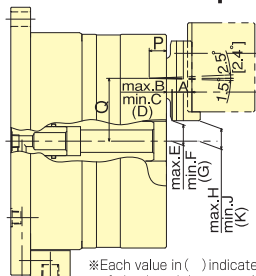

*Each value in () indicate that surface of chuck and Jaw mounting side is parallel.

Dimensions for actuated position (Internal Gripping)

Dimensions	A	B	C	D	E	F	G	H	J	K
Model										
PWS06	15.03	5.59	3.43	4.27	16.28	15.08	15.53	17.17	14.52	15.53



WORK GRIPPER

Internal Pull Lock Work Gripper PUES06

Suitable for 3 to 5-Axis machines
Cost reduction achieved by built-in Cylinder

- Pull back and clamping the inner diameter of workpiece
Suitable for finish machining with stationary machining accuracy.
- Cost reduction achieved by built-in Cylinder
No need to introduce separated Cylinder for Chuck.
- Available on the standard column of machine
Total height is reduced by built-in Cylinder.
- Available to be mounted on NC Rotary Table

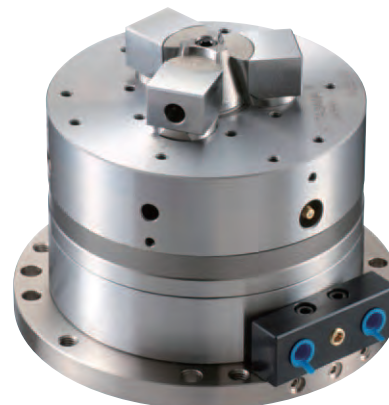

Dimensional Drawings

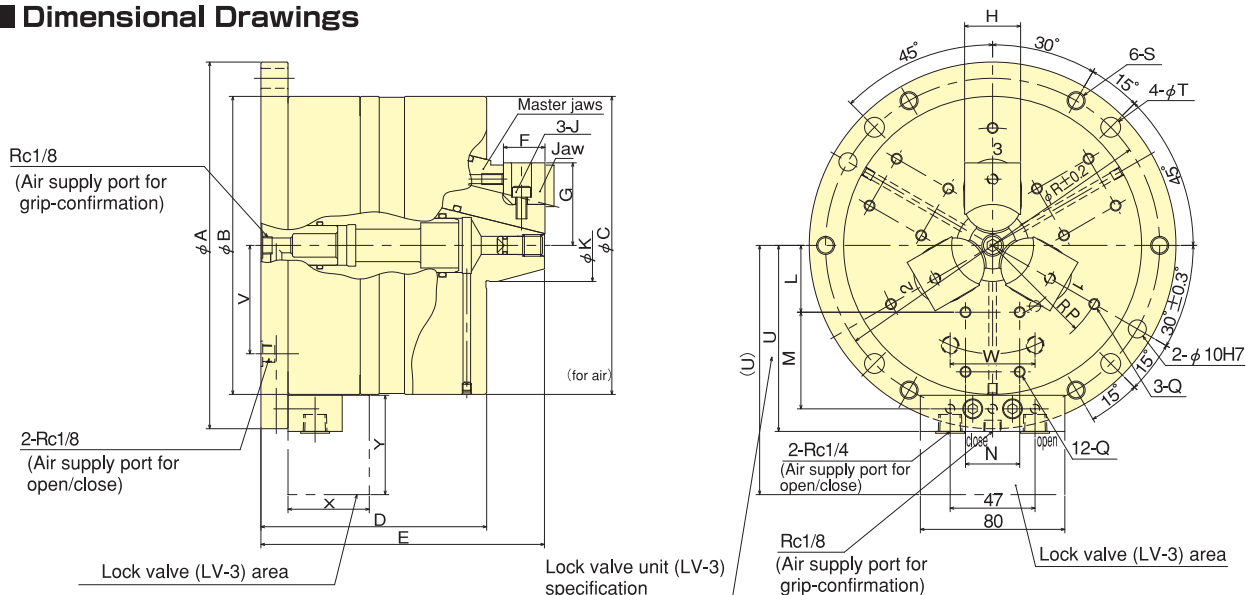

Dimensions ※The dimensions of (U)/X/Y marked are the size of LV-3(Lock-valve).

Dimensions	A	B	C	D	E	F	G		H	J	K	L	M	N	P	Q	R	S	T	U	(U)	V	W	X	Y	
Model	$h7$						max.	min.								$M6$ Depth12										
PUES06	203	165	165	125	157	23	45.7	44.5	31	M6	40	37	33	30	65		185	M10	11	103	1387	60	47	45	55	

Specifications ※Clamping force varies in clamping state for jaws and workpiece. ※Air Consumption = Under Pressure 0.6MPa Plunger Stroke per 10mm

Dimensions	Plunger stroke mm	Jaw stroke (diameter) mm	Gripping force kN (kgf)		Max. allowable pressure MPa (kgf/cm ²)		Min. allowable pressure MPa (kgf/cm ²)	Gripping diameter mm			Mass (with Standard Soft Jaw) kg	Air Consumption (Nl)
			Pneumatic at 0.6MPa (6kgf/cm ²)	Hydraulic at 1.3MPa (13kgf/cm ²)	Pneumatic	Hydraulic		Standard jaws	Option jaws	Master jaws		
PUES06	10	4.8	20 (2039)	57 (5812)	0.7 (7)	1.3 (13)	0.2 (2)	$\phi 70 \sim \phi 89$	$\phi 89 \sim \phi 105$	$\phi 44 \sim \phi 70$	21	0.54

Work Gripper



WORK GRIPPER

Pull Lock Work Gripper

PLS series

Pull Lock for steady gripping
Stable cutting is guaranteed through the high precision and exceptional gripping performance. Can be used as alternative to a fixture

- Stable cutting is performed by high precision and high gripping force
 - Perfect for CNC machining applications, thanks to component detection feature
 - Multiplate system also accommodates PLS Series gripper, allowing up to six grippers per station
 - It's compact design, featuring an inbuilt cylinder allows for more space in the machining envelope
- * CE correspondence



Dimensional Drawings

PLS06, PLS08

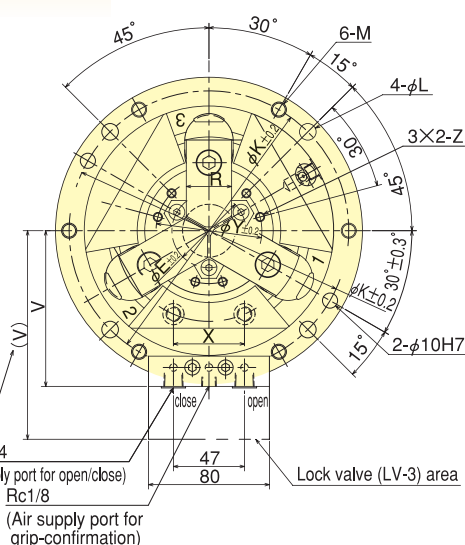
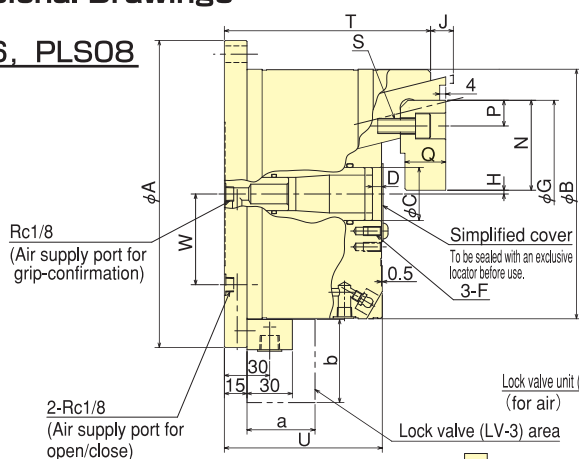

PLS04

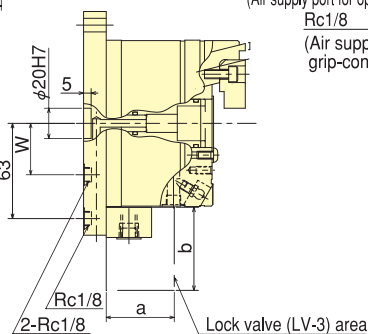

Dimensions *The dimensions of a/b marked are the size of LV-3(Lock-valve).

Dimensions Model	A (h7)	B (0.0/-0.1)	C (0.01/0)	D min.	E	F	G (H6)	H max.	H min.	H max.	H min.	K (±0.2)	L	M	N
PLS04	148	110.1	32	4.5	42	M5×10	84	2.25	0.75	7	1	130	9	M 8	40.5
PLS06	203	165.1	35	6.0	49	M6×12	124	3.75	1.25	15	5	185	11	M10	59.5
PLS08	248	210.1	55	6.0	71	M6×12	154	3.75	1.25	17	7	230	11	M10	74.5

Dimensions Model	P	Q	R	S	T	U	V	(V)	W	X	Y	Z	a	b
PLS04	9.5	14	20	M 6	103	85.5	75.5	110.5	34	33	62	M5×10	45	55
PLS06	17	27	30	M10	136.5	104.5	103	138	60	47	70	M6×12	45	55
PLS08	20.5	31	35	M12	155.5	118.5	125.5	160.5	80	47	95	M6×12	45	55

Specifications *Clamping force varies in clamping state for jaws and workpiece. *Air Consumption = Under Pressure 0.6MPa Plunger Stroke per 10mm

Specifications Model	Plunger stroke mm	Jaw stroke (diameter) mm	Gripping force kN (kgf)				Max. allowable pressure MPa (kgf/cm ²)		Min. allowable pressure MPa (kgf/cm ²)	Gripping diameter mm		Weight (with standard soft jaw) kg	Air Consumption (N ℓ)
			Pneumatic at 0.6MPa (6kgf/cm ²)		Hydraulic at 1.3MPa (13kgf/cm ²)		Pneumatic	Hydraulic		Max.	Min.		
			Use of soft jaw	Use of hardened jaw	Use of soft jaw	Use of hardened jaw							
PLS04	6	3	6.7 (683)	7.4 (754)	16.0(1631)	17.4(1774)	0.7 (7.0)	1.3 (13.0)	0.2 (2.0)	φ60	φ4	7.4	0.22
PLS06	10	5	18.5(1886)	22.0(2243)	40.0(4078)	45.0(4588)				φ100	φ7	18.0	0.54
PLS08	10	5	37.0(3772)	40.0(4078)	80.0(8157)	84.0(8565)				φ130	φ7	33.0	0.93



WORK GRIPPER

Jig Module JM200

Securely grips a wide range of irregularly shaped components
New clamping system accommodates a variety of workpieces

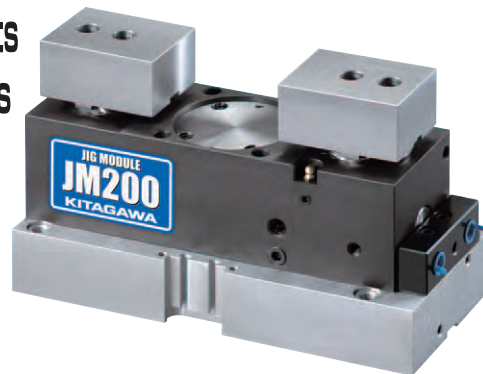

- Option of lock valve mechanism meaning that during machining work can be held without air line
- Centralizing or compensating is switchable
- Face grip (end grip) is possible
- Seating can be checked automatically

One unit is equipped with three gripping functions.

Centralizing Grip Centralizing

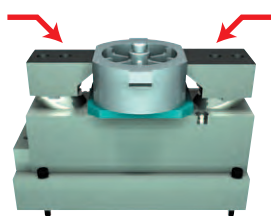

External gripping by pull down

Center compensation grip Compensating

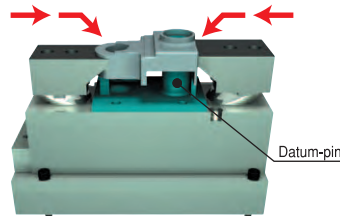

Compensating gripping using pin locators and pull down

End face grip Face Grip

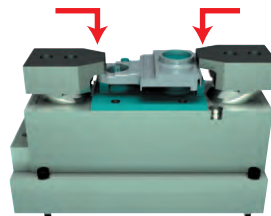

Face gripping by pull down

Seating can be checked

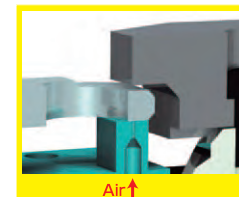

Dimensional Drawings

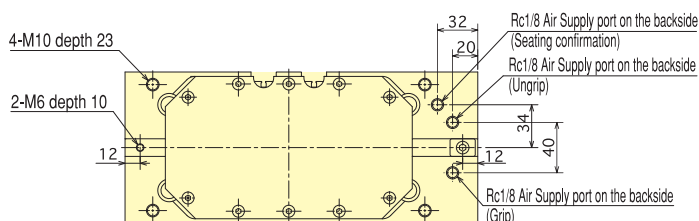
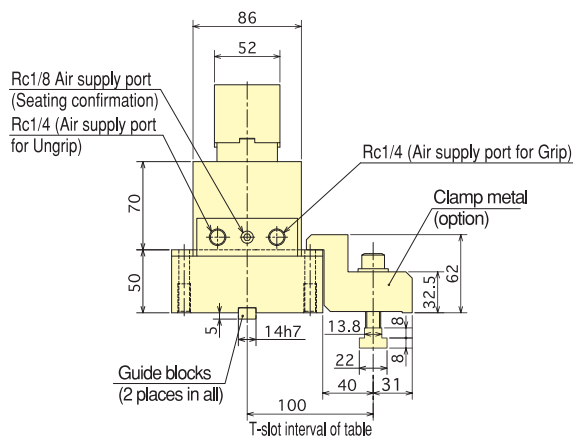
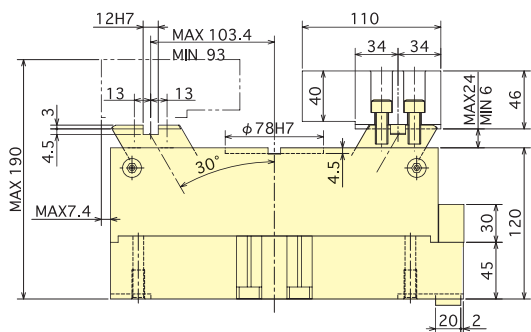
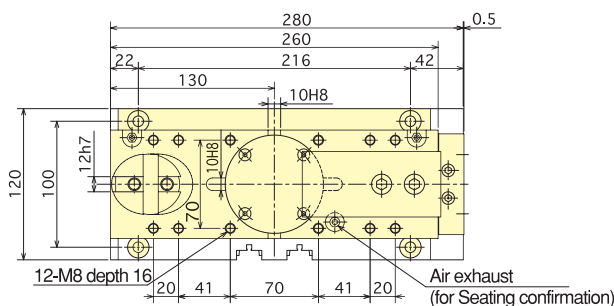

Note : Grip metals for mounting main part can be optionally offered.

Specifications

Cylinder stroke (mm)	Jaw stroke (mm)		Max. Gripping force kN (kgf)		Min. Gripping force kN (kgf)		Max. Oscillating amount (mm)		Work size (mm)		Weight (kg)	Max. air pressure MPa (kgf/cm ²)	Max. air pressure MPa (kgf/cm ²)
	Centering/Compensation	Face grip	Centering/Compensation	Face grip	Centering/Compensation	Face grip	Centering/Compensation	Face grip	Centering/Compensation	Face grip			
18	20.8	18	9.0(918)	5.5(561)	3.0(306)	1.8(184)	1.5	2.5	40~200	40~150	19.0	0.6(6.0)	0.2(2.0)



WORK GRIPPER

Stationary Scroll Chuck SC-S series

**Durable, reliable and versatile
Stationary scroll chuck**



- Available on multiplate for easy fixture mounting
- Compact designed
- Soft jaw can be machined to adapt to a wide range of machine workpieces
- Uses exclusive handle for clamping

Dimensional Drawings

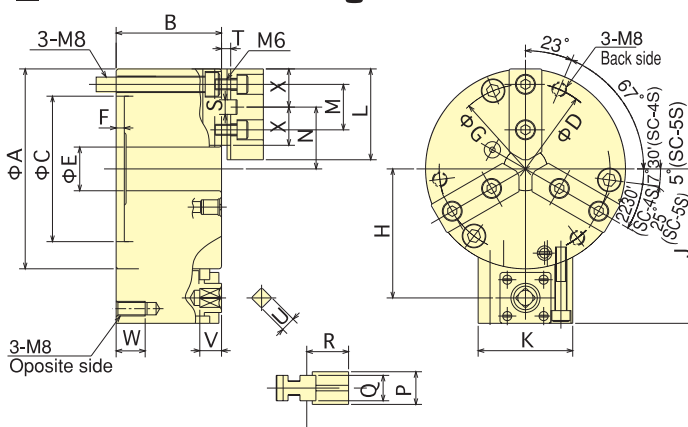
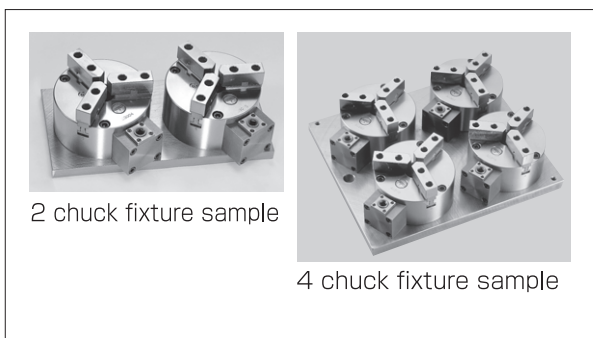

Specifications

Model	Specifications	Max. Gripping force kN (kgf)	Allowable handle torque N·m (kgf·m)	Weight (kg)	Gripping range	
					External mm	Internal mm
SC-4S		9.6 (979)	27.5 (2.8)	4.0	3~95	29~84
SC-5S		12.0 (1224)	39.2 (4.0)	5.3	3~110	33~100

Dimensions

Model	Dimensions																						
	A	B	C (H6)	D	E	F	G	H	J	K	L	M	Nmin	Nmax	P	Q	R	S	T	U	V	W	X
SC-4S	110	58	80	95	24	4.5	93	71	85	52	50	25	26	37	18	14	23	8	5	8	12	16	21
SC-5S	130	60	100	115	32	4.5	113	81	95	56	60	30	30	45	20	16	26	8	6	8	12	16	25

Dimensional Drawings for Soft Jaw

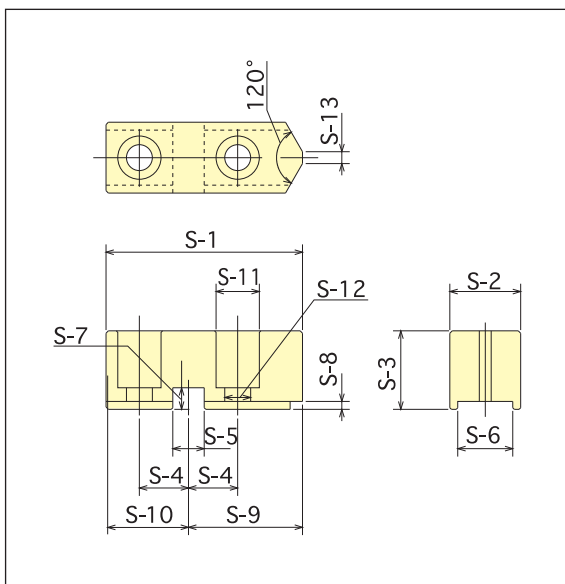

Dimensions for Soft Jaws

Model	Dimensions	chuck size	Soft Jaws					
			S-1	S-2	S-3	S-4 ±0.1	S-5 +0.01/0	S-6 +0.05/+0.02
SBS04S		4	50	18	20	12.5	8	14
SBS05S		5	60	20	22	15	8	16

Model	Dimensions	Soft Jaws						
		S-7	S-8	S-9	S-10	S-11	S-12	S-13
SBS04S		5.5	2	29	21	11	6.6	3
SBS05S		5.5	2	35	25	11	6.6	3

Dimensional Drawings for Handle

Dimensions for Handles

Model	Dimensions						
	a	b	c	d	e	f	g
SC-4S	130	60	17	120	8	10	11
SC-5S	150	60	20	130	10	12	11

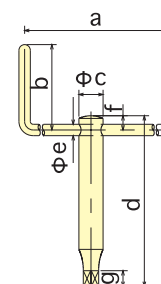



WORK GRIPPER

Option

LV-3

■ Air Lock Valve Unit

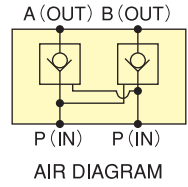
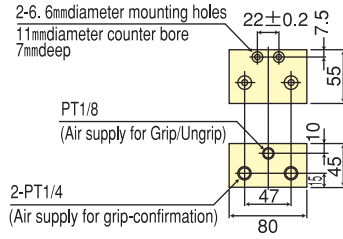
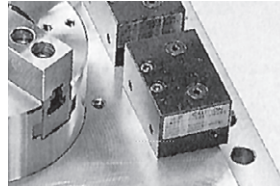
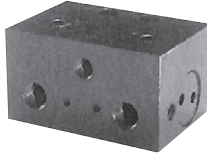

AV-02F

■ Original manual air valve by **KITAGAWA**

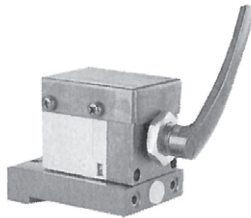

AV-02F allows air system to be simplified

※Valves can be easily mounted onto work gripper and multiplate.

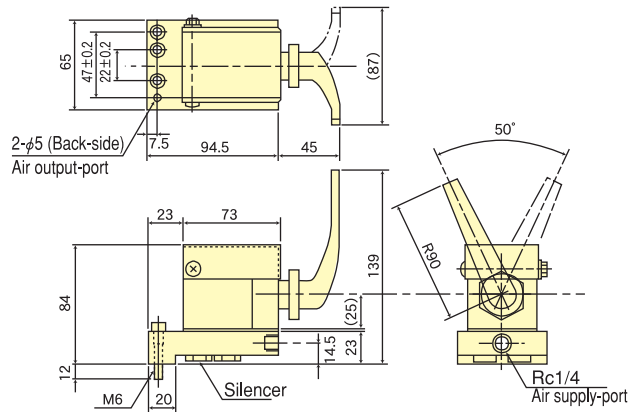

■ Mounting Drawing (by AV-02F)

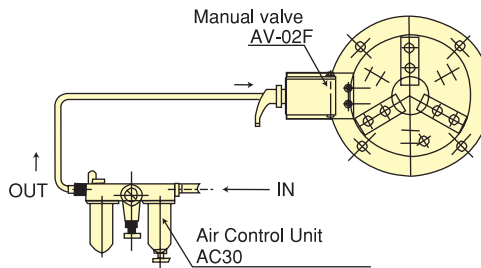

Max. pressure	1MPa (10kgf/cm ²)
Lever movement	50°
Connection port	Rc ¹ / ₄

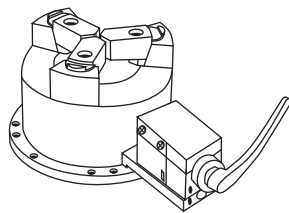

VH-201

■ Manual Air Valve

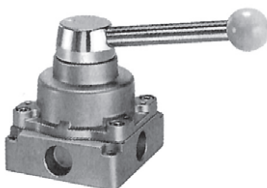

Max. pressure	1MPa (10kgf/cm ²)
Lever movement	90°
Connection port	Rc ¹ / ₄

■ Mounting Drawing (by VH-201)

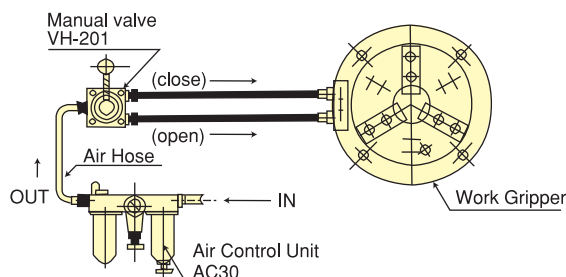

AC30

■ Air Control Unit (With Lubrication)

Max. pressure	1MPa (10kgf/cm ²)
pressure setting range	0.05~0.85MPa (0.5~8.6kgf/cm ²)
Filter mesh	5μm
Max. temperature	60°C
Connection port	Rc ¹ / ₄



CHUCK

▶ **P.87~P.104**

Jaws and Accessories



CHUCK

Soft Jaws for Power Chuck

SB series

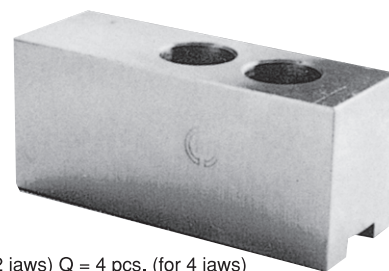

Description of Model **SB06A1-80**

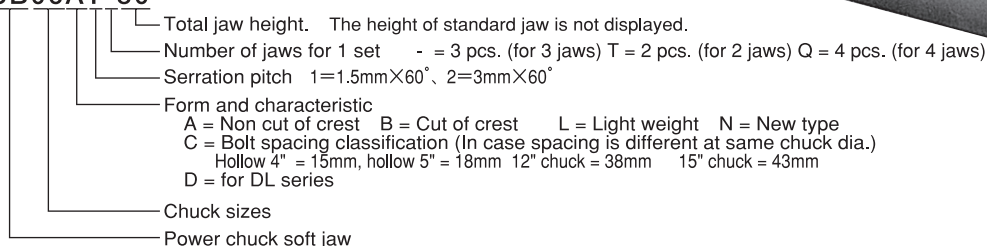

Combination of Soft Jaws ※Chuck models in parentheses are discontinued models.

Standard jaw	High jaw	Adaptive closed centre chuck	Adaptive open centre chuck
SB04C1	SB04C1-036, SB04C1-048		(B-04, HOB-4)
SB04C1T	SB04C1T048		(BT04, HOBT-4)
SB04B1	SB04A1-036, SB04A1-048	N-04 (HJ-4), AS04, NL04, NRC04	
SB04A1T	SB04A1T048	NT04, AT04	
SB04N1	SB04N1-036, SB04N1-048		B-204
SB04N1T			BT204
SB05C1	SB05C1-038, SB05C1-053		(B-05, HOB-5)
SB05C1T	SB05C1T053		(BT05, HOBT-5)
SB05B1	SB05A1-038, SB05A1-053	N-05 (HJ-5)	
SB05A1T	SB05A1T053	NT05	
SB05N1	SB05N1-038, SB05N1-053		B-205
SB05N1T			BT205
SB06B1	SB06A1-066	N-06, NL06, AS06, NRC06, (HJA5-6)	BB206, B-06 (HOB-6, HOS-6, HO-6, HOH-06K, BB06)
SB06A1T	SB06A1T066	NT06, NLTO6, AT06	(BT06, HOBT-6)
SB06C1		(HT-6)	UVE160K
SB06D1		DL206 (DL06)	
SB06L1A			BS306, B-206, HOH-206, BL206
SB06L1T			BT206
SB08B1	SB08A1-056, SB08A1-076	N-08, NL08, AS08, NRC08, DL208 (DL08), (HJA6-8)	BB208, BS308, B-208, HOH-208, BL208, B-08 (HOB-8, HOS-8, HO-8, HOH-08K, BB08)
SB08B1Q	SB08B1Q-76	HW-08	
SB08A1T	SB08A1T056, SB08A1T076	NT08, NLTO8, AT08	BT208, (BT08, HOBT-8)
SB10A1		NL10, AS10, NRC10	
SB10B1	SB10A1-056, SB10A1-080, SB10A1-116	N-10, (HJA6-8-10)	BB210, BS310, B-210, BL210, B-10, (HOB-10, HOS-10, HO-10), HOH-10K, UVE200K, UVE250K
SB10A2Q	SB10A2Q080	HW-10, 12	
SB10A2	SB10A2-080	(HJ-10)	
SB10A1T	SB10A1T080	NT10, NL10, AT10	BT210, (BT10, HOBT-10)
SB10D1		DL210 (DL10)	
SB12A1	SB12A1-090	N-12, NL12, DL212 (DL12), (HJA6-8-12)	B-12, (HOB-12, HOS-12), HOH-12K
SB12C1			UVE315K, (HO-12)
SB12A1T	SB12A1T090	NT12, NL12	(BT12, HOBT-12)
SB12N1	SB12N1-090		BB212, B-212, BL212
SB12N1T			BT212, BLT212
SB15C1	SB15C1-110		B-15-18, (HOB-15-18, HO-15, HOS-15), HOH-15K
SB15A1	SB15A1-110	(HJA8-15-18-21, HJA11-15)	
SB15A2		(HJ-15)	UVE400K
SB15A2Q		HW-15	
SB15C1T			(BT15, HOBT-15)
SB15N1	SB15N1-110	N-15, N-18	B-215
UVE500AR			(UVE500AR)
SB18A2	SB18A2-110	N-21, N-24, (HJ-18-21, HJA11-18-21)	B-21-24, (HOB-21-24, UVE500K-630K, UVE500AR-630AR, UVE500L, UVE630L, UVE500LB, UVE630LB)
SB24A2	SB24A2-130	(HJA11-24, HJ-24)	(UVE800K, UVE750AR, UVE800LB)
SB06BB	SB06BB-040		QB306, (QB206)
SB08BB	SB08BB-056		QB308, (QB208)
SB10BB	SB10BB-060		QB310, (QB210)
SB12BB	SB12BB-070		QB312, (QB212)
PW-06		PW-06	
PW-08		PW-08	
PW-10		PW-10	
PW-12		PW-12	
PW-15		PW-15	

■ Combination Table for Standard Soft Jaws

Chuck	Soft jaw	Chuck	Soft jaw
B-204	SB04N1	N-04	SB04B1
B-205	SB05N1	N-05	SB05B1
B-206	SB06L1A	N-06	SB06B1
B-208	SB08B1	N-08	SB08B1
B-210	SB10B1	N-10	SB10B1
B-212	SB12N1	N-12	SB12A1
B-215	SB15N1	N-15	SB15N1
		N-18	SB15N1
B-04	SB04C1	N-21	SB18A2
B-05	SB05C1	N-24	SB18A2
B-06	SB06B1		
B-08	SB08B1	NL04	SB04B1
B-10	SB10B1	NL06	SB06B1
B-12	SB12A1	NL08	SB08B1
B-15	SB15C1	NL10	SB10A1
B-18	SB15C1	NL12	SB12A1
B-21	SB18A2		
B-24	SB18A2	NT04	SB04A1T
		NT05	SB05A1T
BB206	SB06B1	NLT06	SB06A1T
BB208	SB08B1	NLT08	SB08A1T
BB210	SB10B1	NLT10	SB10A1T
BB212	SB12N1	NLT12	SB12A1T
BB06	SB06B1		
BB08	SB08B1	HW-08	SB08B1Q
		HW-10	SB10A2Q
BS306	SB06L1A	HW-12	SB10A2Q
BS308	SB08B1	HW-15	SB15A2Q
BS310	SB10B1		
		UVE160K	SB06C1
BL206	SB06L1A	UVE200K	SB10B1
BL208	SB08B1	UVE250K	SB10B1
BL210	SB10B1	UVE315K	SB12C1
BL212	SB12N1	UVE400K	SB15A2
		UVE500LB	SB18A2
HOH-206	SB06L1A	UVE500AR	UVE500AR
HOH-208	SB08B1	UVE630LB	SB18A2
HOH-10K	SB10B1	UVE630AR	SB18A2
HOH-12K	SB12A1	UVE750AR	SB24A2
HOH-15K	SB15C1	UVE800LB	SB24A2
QB306	SB06BB	UB450K	UB450
QB308	SB08BB	UB560K	UB560K
QB310	SB10BB	UB630K	UB710
QB312	SB12BB	UB710K	UB710
BT204	SB04N1T	DL206	SB06D1
BT205	SB05N1T	DL208	SB08B1
BT206	SB06L1T	DL210	SB10D1
BT208	SB08A1T	DL212	SB12A1
BT210	SB10A1T	DL06	SB06D1
BT212	SB12N1T	DL08	SB08B1
BT-04	SB04C1T	DL10	SB10D1
BT-05	SB05C1T	DL12	SB12A1
BT-06	SB06A1T		
BT-08	SB08A1T		
BT-10	SB10A1T		
BT-12	SB12A1T		
BT-15	SB15C1T		

■ Combination Table for Standard Soft Jaws

Chuck	Soft jaw	Chuck	Soft jaw
PW-06	SBPW-06	AT04	SB04A1T
PW-08	SBPW-08	AT06	SB06A1T
PW-10	SBPW-10	AT08	SB08A1T
PW-12	SBPW-12	AT10	SB10A1T
PW-15	SBPW-15		
		NRC04	SB04B1
AS04	SB04B1	NRC06	SB06B1
AS06	SB06B1	NRC08	SB08B1
AS08	SB08B1	NRC10	SB10B1
AS10	SB10A1		

■ Interchangeable High jaws with standard jaws

Standard jaw	High jaw
SB04C1	SB04C1-036, SB04C1-048
SB04C1T	SB04C1T048
SB04B1	SB04A1-036, SB04A1-048
SB04A1T	SB04A1T048
SB04N1	SB04N1-036, SB04N1-048
SB05C1	SB05C1-038, SB05C1-053
SB05C1T	SB05C1T053
SB05B1	SB05A1-038, SB05A1-053
SB05A1T	SB05A1T053
SB05N1	SB05N1-038, SB05N1-053
SB06B1	SB06A1-066
SB06A1T	SB06A1T066
SB08B1	SB08A1-056, SB08A1-076
SB08B1Q	SB08B1Q-76
SB08A1T	SB08A1T056, SB08A1T076
SB10B1 (A1)	SB10A1-056, SB10A1-080, SB10A1-116
SB10A2Q	SB10A2Q080
SB10A2	SB10A2-080
SB10A1T	SB10A1T080
SB12A1	SB12A1-090
SB12A1T	SB12A1T090
SB12N1	SB12N1-090
SB15A1	SB15A1-110
SB15C1	SB15C1-110
SB15N1	SB15N1-110
SB18A2	SB18A2-110
SB24A2	SB24A2-130
SB06BB	SB06BB-040
SB08BB	SB08BB-056
SB10BB	SB10BB-060
SB12BB	SB12BB-070

Ref. DWG. 1

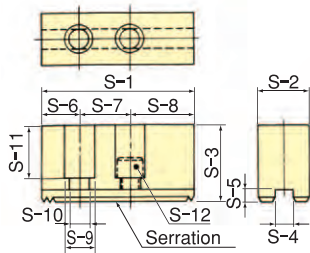

Ref. DWG. 2

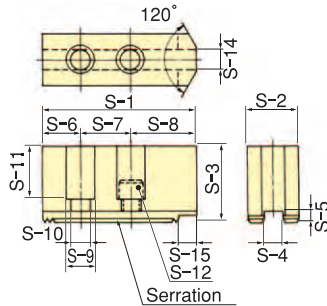

Ref. DWG. 3

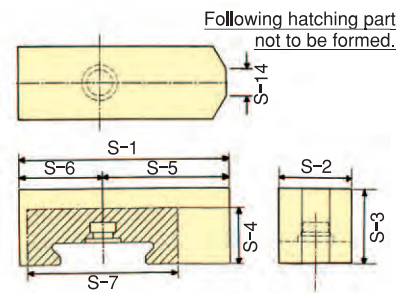

Dimensions

Soft Jaw TYPE	S-1	S-2	S-3	S-4	S-5	S-6	S-7	S-8	S-9	S-10	S-11	S-12	S-14	S-15	Serration pitch	Ref. DWG.
SB04C1	48	19	23	8	3	8	15	25	11	6.6	15	M6	6		1.5x60°	2
SB04C1-036	48	19	36	8	3	8	15	25	11	6.6	28	M6			1.5x60°	1
SB04C1-048	48	19	48	8	3	8	15	25	11	6.6	40	M6			1.5x60°	1
SB04C1T	48	19	23	8	3	8	15	25	11	6.6	15	M6			1.5x60°	1
SB04C1T048	48	19	48	8	3	8	15	25	11	6.6	40	M6			1.5x60°	1
SB04B1	55	23	25	10	4	13	14	28	13.5	8.5	16	M8	3	13	1.5x60°	2
SB04A1-036	55	23	36	10	4	13	14	28	13.5	8.5	27	M8			1.5x60°	1
SB04A1-048	55	23	48	10	4	13	14	28	13.5	8.5	39	M8			1.5x60°	1
SB04A1T	55	23	25	10	4	13	14	28	13.5	8.5	16	M8			1.5x60°	1
SB04A1T048	55	23	48	10	4	13	14	28	13.5	8.5	39	M8			1.5x60°	1
SB04N1	49.5	23	23	10	4	10	14	25.5	13.5	8.5	14.5	M8	4		1.5x60°	2
SB04N1T	49.5	23	23	10	4	10	14	25.5	13.5	8.5	14.5	M8			1.5x60°	1
SB04N1-036	49.5	23	36	10	4	10	14	25.5	13.5	8.5	27.5	M8			1.5x60°	1
SB04N1-048	49.5	23	48	10	4	10	14	25.5	13.5	8.5	39.5	M8			1.5x60°	1
SB05C1	57	23	31	10	3	10	18	29	13.5	8.5	22	M8	12		1.5x60°	2
SB05C1-038	57	23	38	10	3	10	18	29	13.5	8.5	29	M8			1.5x60°	1
SB05C1-053	57	23	53	10	3	10	18	29	13.5	8.5	44	M8			1.5x60°	1
SB05C1T	57	23	31	10	3	10	18	29	13.5	8.5	22	M8			1.5x60°	1
SB05C1T053	57	23	53	10	3	10	18	29	13.5	8.5	44	M8			1.5x60°	1
SB05B1	62	23	27	10	4	14	19	29	13.5	8.5	18	M8	12	14	1.5x60°	2
SB05A1-038	62	23	38	10	4	14	19	29	13.5	8.5	29	M8			1.5x60°	1
SB05A1-053	62	23	53	10	4	14	19	29	13.5	8.5	44	M8			1.5x60°	1
SB05A1T	62	23	27	10	4	14	19	29	13.5	8.5	18	M8			1.5x60°	1
SB05A1T053	62	23	53	10	4	14	19	29	13.5	8.5	44	M8			1.5x60°	1
SB05N1	54	23	25	10	4	12	14	28	13.5	8.5	16.5	M8	5		1.5x60°	2
SB05N1T	54	23	25	10	4	12	14	28	13.5	8.5	16.5	M8			1.5x60°	1
SB05N1-038	54	23	38	10	4	12	14	28	13.5	8.5	29.5	M8			1.5x60°	1
SB05N1-053	54	23	53	10	4	12	14	28	13.5	8.5	44.5	M8			1.5x60°	1
SB06B1	72	31	32	12	5	15	20	37	17	11	20	M10	12	15	1.5x60°	2
SB06A1-066	72	31	66	12	5	15	20	37	17	11	54	M10			1.5x60°	1
SB06A1T	72	31	32	12	5	15	20	37	17	11	20	M10			1.5x60°	1
SB06A1T066	72	31	66	12	5	15	20	37	17	11	54	M10			1.5x60°	1
SB06C1	76.5	40	37	14	5	15	25	36.5	19	13	22	M12			1.5x60°	1
SB06D1	72	31	32	12	5	22	20	30	17	11	20	M10	6	15	1.5x60°	2
SB06L1A	66	26	28	12	5	12	20	34	17	11	16	M10	5	12	1.5x60°	2
SB06L1T	66	26	28	12	5	12	20	34	17	11	16	M10			1.5x60°	1
SB08B1	95	35	38	14	5	24	25	46	19	13	23	M12	12	20	1.5x60°	2
SB08A1-056	95	35	56	14	5	24	25	46	19	13	41	M12			1.5x60°	1
SB08A1-076	95	35	76	14	5	24	25	46	19	13	61	M12			1.5x60°	1
SB08B1Q	90	31	38	12	5	24	20	46	17	11	26	M10	16	24	1.5x60°	2
SB08B1Q-76	90	31	76	12	5	24	20	46	17	11	64	M10	16	24	1.5x60°	2
SB08A1T	95	35	38	14	5	24	25	46	19	13	23	M12			1.5x60°	1
SB08A1T056	95	35	56	14	5	24	25	46	19	13	41	M12			1.5x60°	1
SB08A1T076	95	35	76	14	5	24	25	46	19	13	61	M12			1.5x60°	1
UB450	165	62	66	25.5	8	37	43	85	32	21	43	M20			3.0x60°	1
UB560K	180	65	69.2	25.5	8	39.5	60	80.5	32	21	45.3	M20			3.0x60°	1
UB710	209.5	75	80	30	9	40	60	109.5	39	26	55	M24			3.0x60°	1

Ref. DWG. 4

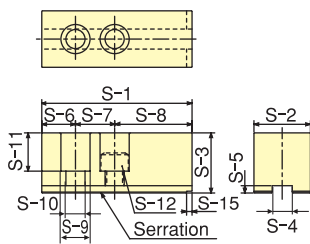

Ref. DWG. 5

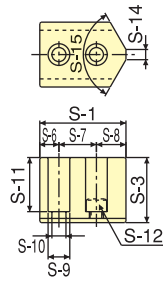
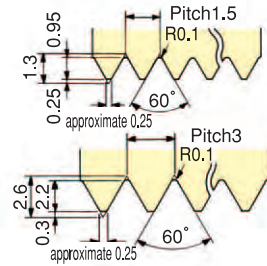
Ref. DWG. 1, 2, 4
Serration

Dimensions

Soft Jaw TYPE	S-1	S-2	S-3	S-4	S-5	S-6	S-7	S-8	S-9	S-10	S-11	S-12	S-14	S-15	Serration pitch	Ref. DWG.
SB10B1	110	40	42	16	5	30	30	50	19	13	27	M12	15	20	1.5×60°	2
SB10A1	110	40	42	16	5	30	30	50	19	13	27	M12			1.5×60°	1
SB10A1-056	110	40	56	16	5	30	30	50	19	13	41	M12			1.5×60°	1
SB10A1-080	110	40	80	16	5	30	30	50	19	13	65	M12			1.5×60°	1
SB10A1-116	110	40	116	16	5	30	30	50	19	13	101	M12			1.5×60°	1
SB10A2Q	110	40	42	16	6	30	30	50	19	13	26	M12			3.0×60°	1
SB10A2Q080	110	40	80	16	6	30	30	50	19	13	64	M12			3.0×60°	1
SB10A2	110	40	42	16	6	30	30	50	19	13	26	M12			3.0×60°	1
SB10A2-080	110	40	80	16	6	30	30	50	19	13	65	M12			3.0×60°	1
SB10A1T	110	40	42	16	5	30	30	50	19	13	27	M12			1.5×60°	1
SB10A1T080	110	40	80	16	5	30	30	50	19	13	65	M12			1.5×60°	1
SB10D1	101.5	45	45	18	5	22.5	30	49	22	15	25	M14	15	17.5	1.5×60°	2
SB12A1	129	50	50	18	5	39	30	60	22	15	30	M14			1.5×60°	1
SB12A1-090	129	50	90	18	5	39	30	60	22	15	70	M14			1.5×60°	1
SB12C1	129	50	50	18	5	32	38	59	22	15	35	M14			1.5×60°	1
SB12A1T	129	50	50	18	5	39	30	60	22	15	30	M14			1.5×60°	1
SB12A1T090	129	50	90	18	5	39	30	60	22	15	70	M14			1.5×60°	1
SB12N1	111	50	50	21	4	21	30	60	25	17	33	M16			1.5×60°	1
SB12N1-090	111	50	90	21	4	21	30	60	25	17	73	M16			1.5×60°	1
SB12N1T	111	50	50	21	4	21	30	60	25	17	33	M16		6	1.5×60°	1
SB15C1	165	62	66	22	8	37	43	85	32	21	42	M20		6	1.5×60°	4
SB15C1-110	165	62	110	22	8	37	43	85	32	21	86	M20			1.5×60°	4
SB15A1	156	62	70	22	8	36	60	60	32	21	45	M20			1.5×60°	1
SB15A1-110	156	62	110	22	8	36	60	60	32	21	85	M20			1.5×60°	1
SB15A2	156	62	70	22	9	36	60	60	32	21	45	M20			3.0×60°	1
SB15A2Q	129	50	50	18	6	32	38	59	22	15	34	M14		6	3.0×60°	1
SB15C1T	165	62	66	22	8	37	43	85	32	21	42	M20			1.5×60°	4
SB15N1	135	50	60	25.5	5	26	43	66	32	21	39	M20			1.5×60°	1
SB15N1-110	135	50	110	25.5	5	26	43	66	32	21	89	M20			1.5×60°	1
UVE500AR	210	65	100	25	9	40	60	110	32	21	75	M20			3.0×60°	1
SB18A2	180	65	70	25	9	40	60	80	32	21	45	M20			3.0×60°	1
SB18A2-110	180	65	110	25	9	40	60	80	32	21	85	M20			3.0×60°	1
SB24A2	210	75	90	25	9	40	80	90	32	21	65	M20			3.0×60°	1
SB24A2-130	210	75	130	25	9	40	80	90	32	21	105	M20			3.0×60°	1
SB06BB	90	32	30	24	54	36	68							5		3
SB06BB-040	90	32	40	24	54	36	68							5		3
SB08BB	106	37	38	28	64	42	76							14		3
SB08BB-056	106	37	56	28	64	42	76							14		3
SB10BB	125	42	42	31	76	49	88							26		3
SB10BB-060	125	42	60	31	76	49	88							26		3
SB12BB	139	42	50	34	90	49	92							30		3
SB12BB-070	139	42	70	34	90	49	92							30		3
PW-06	67.5	50.8	51	38.07	3.3	15	29.36	23.14	17	11	42.4	M10	8	120°		5
PW-08	74	57	57.47	44.45	3.3	15	34.14	24.86	20	13.5	47	M12	41	90°		5
PW-10	89.5	70.1	70.2	57.1	3.3	19	44.45	26.05	25	17	59	M16				5
PW-12	108.5	70.1	70.2	57.1	3.3	19	44.45	45.05	25	17	59	M16				5
PW-15	140	76.2	76.5	66.62	3.3	23.9	53.98	62.12	32	21	61.2	M20				5



CHUCK

Hard Jaws for Power Chuck HB series

Description of Model HB06B1

- Serration pitch
1=1.5mm×60°, 2=3mm×60°, 3=1/16"×90°, 4=3/32"×90°
- Form and characteristic
A = 3-step jaw B = 2-step jaw
C = Bolt spacing classification (In case spacing is different at same chuck dia.)
U = for UVE N = New type
- Chuck sizes
- Power chuck hard jaw

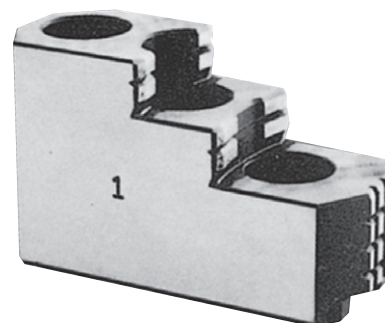

Combination of Hard Jaws *Chuck models in parentheses are discontinued models.

Hard Jaw TYPE	Adaptive closed centre chuck	Adaptive open centre chuck
HBO4B1		(B-04)
HBO4N1	N-04	B-204, B-205
HBO5B1		(B-05)
HBO5C1	N-05	
HBO6A1	N-06, NL06, (HJA5-6)	BB206, BS306, B-206, HOH-206, BL206, (BB06)
HBO6B1	N-06, NL06, (HJA5-6)	BB206, BS306, B-206, HOH-206, BL206, (BB06) B-06, (HOB-6, HOS-6, HO-6)
HBO8A1	N-08, NL08, (HJA6-8)	B-208, HOH-208, BL208, B-08, (HOB-8, HOS-8, HO-8)
HBO8B1		BB208, BS308
HBO8N1		(BB08)
HB10A1	N-10, NL10, (HJA6-8-10)	B-210, HOH-10K, BL210, B-10, (HOB-10, HOS-10, HO-10)
HB10AA1		BB210, BS310
HB12B1	N-12, NL12, (HJA6-8-12, HLA6-12, HLA6-8-15)	HOH-12K, B-12, (HOB-12, HOS-12, HO-12)
HB12C1		(HO-12)
HB12N1		BB212, B-212, BL212
HB15A1		HOH-15K, B-15, (HOB-15, HOS-15, HO-15), B-18, (HOB-18)
HB15B1	(HJA8-15-18-21, HJA11-15, HLA-18-21)	
HB15N1	N-15, N-18, NV15, NV18	B-215
HB18B2	N-21, N-24, NV21, NV24, NV28, NV32, NV36, NV40, (HJA11-18-21, HJA15-21)	B-21 (HOB-21), B-24 (HOB-24) (UVE500, UVE630)
HB24B2	(HJA11-15-24)	(UVE800)
HBO6U1		UVE160K
HBO8U1		UVE200K, UVE250K
HB12U1		UVE315K
HB16U2		UVE400K
HB18W2		UB450K

Ref. DWG. 1

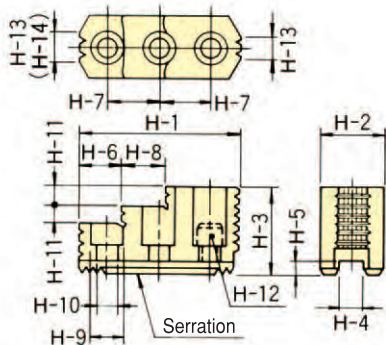

Ref. DWG. 2

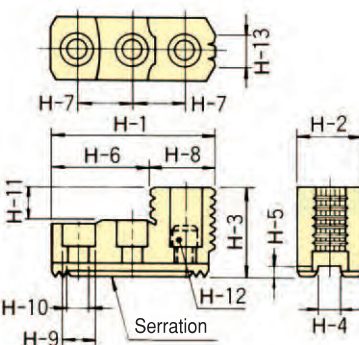

Ref. DWG. 3

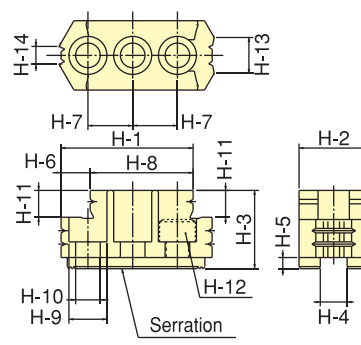

Dimensions

Hard Jaw TYPE	H-1	H-2	H-3	H-4	H-5	H-6	H-7	H-8	H-9	H-10	H-11	H-12	H-13	H-14	Serration pitch	Ref. DWG.
HBO4B1	46	19	23	8	3	15	15	23.5	11	6.6	9	M 6	6	-	1.5	3
HBO4N1	53	23	27.5	10	4	30.5	14	22.5	13.5	8.5	10	M 8	6	-	1.5	2
HBO5B1	55.5	23	31	10	3	22.5	18	21.5	13.5	8.5	14	M 8	6	-	1.5	3
HBO5C1	61	23	30	10	4	7.5	19	53.5	13.5	8.5	12	M 8	6	-	1.5	2
HBO6A1	66.6	31	36	12	5	40	20	26.6	17	11	12	M10	10	-	1.5	2
HBO6B1	67.5	31	35	12	5	13	20	46	17	11	12	M10	16	10	1.5	3
HBO8A1	86	35	51	14	5	31	25	18	19	13	12	M12	12	12	1.5	1
HBO8B1	92	35	51	14	5	12	25	63	19	13	18	M12	11	11	1.5	3
HBO8N1	88	35	51	14	5	36	25	14	19	13	12	M12	12	11	1.5	1
HB10A1	99.5	40	54	16	5	43	30	17	19	13	13	M12	15	15	1.5	1
HB10AA1	102.5	40	54	16	5	43	30	17	19	13	13	M12	15	15	1.5	1
HB12B1	97.5	50	55	18	5	64.5	30	33	23	15	20	M14	30	-	1.5	2
HB12C1	113	50	50	18	5	69.5	38	43.5	22	15	20	M14	18	-	1.5	2
HB12N1	103	50	52	21	4	62.5	30	40.5	25	17	17	M16	30	-	1.5	2
HB15A1	149	62	86	22	8	63	43	34	32	21	20	M20	40	40	1.5	1
HB15B1	141.75	70	77.5	22	8	87.75	43	54	32	21	30	M20	50	-	1.5	2
HB15N1	149	62	86	25.5	5	69	43	27	32	21	20	M20	43	38	1.5	1
HB18B2	159.5	80	90	25	9	104.5	50	55	32	21	40	M20	55	-	3.0	2
HB24B2	183.5	90	105	25	9	116.5	60	67	32	21	50	M20	76	-	3.0	2
HBO6U1	69.5	35	48	14	5	34	19	18	19	13	12	M12	12	20	1.5	1
HBO8U1	79.25	40	42	16	5	35.25	21	44	19	13	14	M12	12	-	1.5	2
HB12U1	107.25	45	50	18	5	56.75	30	50.5	22	15	20	M14	25	-	1.5	2
HB16U2	138.5	60	71	22	9	76.5	43	62	32	21	26	M20	35	-	3.0	2
HB18W2	155.5	60	85	25.5	9	79.5	43	24	32	21	20	M20	38	-	3.0	1



T-nut

Ref. DWG. 1

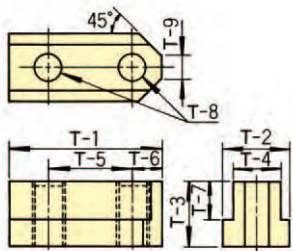

※T-8 is the size of soft jaw mounting bolt.

Ref. DWG. 2

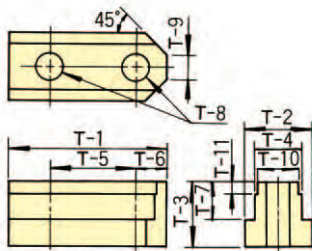

※T-8 is the size of soft jaw mounting bolt.

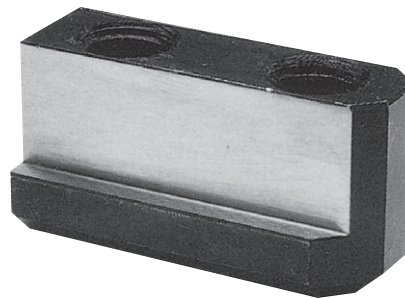

Ref. DWG. 3

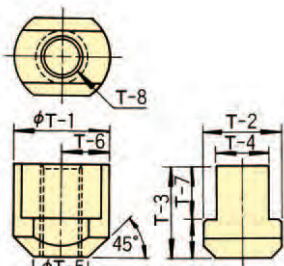

※T-8 is the size of soft jaw mounting bolt.

Ref. DWG. 4

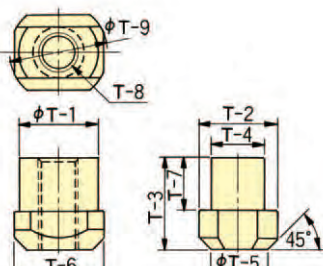

※T-8 is the size of soft jaw mounting bolt.

Ref. DWG. 5

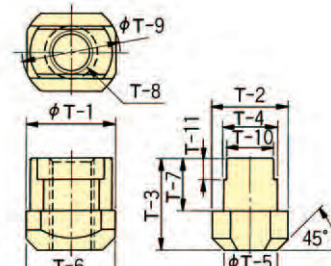

※T-8 is the size of soft jaw mounting bolt.

※Please inform us of the chuck type and T-Nut dimensions before ordering.

Dimensions and Combination

※Chuck models in brackets are discontinued models.

T-1	T-2	T-3	T-4	T-5	T-6	T-7	T-8	T-9	T-10	T-11	Adaptive chuck	Ref. DWG.
24.5	11.5	13.5	8	15	4.5	9	M6	5	—	—	(B-04, BT04)	1
26	14.5	15	10	14	6	9.5	M8	5	—	—	B-204, BT204, B-205, BT205	1
26	14.5	18	10	14	6	12.5	M8	5	—	—	N-04, NT04, NL04, AS04, AT04, NRC04, (HJ-4)	1
30	14	15.5	10	18	6	10	M8	5	—	—	(B-05, BT05, HOB-5, HOBT-5)	1
32	14.5	18	10	19	6	12.5	M8	6	—	—	N-05, NT05, (HJ-5)	1
36.5	17	18.5	12	20	8.25	11	M10	8	—	—	HW-08	1
36.5	17	22.5	12	20	7.5	15	M10	8	—	—	N-06, (NT06, HJ-6), NL06, NLT06, AS06, AT06, NRC06	1
46.5	20	20.5	14	25	10.5	12	M12	12	—	—	B-208, BB208, BS308, BT208, HOH-208, BL208, BLT208	1
48	20	25.5	14	25	11	16	M12	8	—	—	N-08, (NT08, HJ-8), NL08, NLT08, AS08, AT08, NRC08	1
51	22	21.5	16	30	11	13	M12	11	—	—	B-210, BB210, BS310, BT210, BL210, BLT210	1
55	22	25.5	16	30	11	16	M12	8	—	—	N-10, (NT10, HJ-10), NL10, NLT10, AS10, AT10, NRC10, HW-10, HW-12	1
56.25	29.5	22.75	21	30	12	11.25	M16	9.5	—	—	BB212	1
55.5	29.5	27.75	21	30	12	16.25	M16	13	—	—	B-212, BT212, BL212, BLT212	1
55.5	26.5	31	18	30	11.5	17.5	M14	12	—	—	HOH-12K	1
55.5	26.5	33.5	18	30	11.5	20	M14	12	—	—	N-12, (NT12), NL12, NLT12	1
62.5	26.5	33.5	18	38	12	20	M14	12	—	—	HW-15, (HJ-12)	1
90	37.5	45	25	50	20	26	M20	16	—	—	B-21-24, (HOB-21-24) For hard jaw	1
100	37.5	45	25	60	20	26	M20	16	—	—	B-21-24, (HOB-21-24) For soft jaw	1
100	37.5	54	25	60	20	35	M20	16	—	—	(HO-18)	1
100	40	54	25	60	20	35	M20	16	—	—	(HJ-18, HJ-21)	1
120	40	54	25	60	20	35	M20	16	—	—	(HJA11-24 For hard jaw)	1
120	40	54	25	60	20	35	M20	16	—	—	(HJ-24, HJA11-15-24)	1
80	33.5	40.5	24	43	17	24	M20	11	22	7.5	HOH-15K	2
80	33.5	45.5	24	43	17	29	M20	11	22	8.2	(HLA8-18, HJA11-15)	2
97	33.5	45.5	24	60	17	29	M20	11	22	8.5	(HJ-15, HJA8-11-15, HLA8-18-21)	2
80	35	39.25	25.5	43	17	20.25	M20	14	—	—	B-215	1
42	35	39.25	25.5	25	—	20.25	M20	—	—	—	N-15, N-18	3
46	37.5	45	25	26.5	—	26	M20	—	—	—	N-21, N-24	3
19	22.5	23.5	14	19.5	19	15	M12	24.5	—	—	UVE160	4
19	22.5	24	16	19.5	19	15.5	M12	24.5	—	—	UVE200, UVE250	4
24	28.5	27.5	18	24	24	17	M14	32	—	—	UVE315	4
32	36	30.5	24	30	32	20	M20	40	22	8.5	UVE400	5
100	36	31.5	25	60	20	21	M20	16	—	—	(UVE500LB, UVE630LB)	1
120	36	31.5	25	80	20	21	M20	16	—	—	(UVE800LB)	1
32	36	31.5	25	30	32	21	M20	40	—	—	(UVE500AR)	4
32	37.5	45.5	25	30	34	26	M20	42	—	—	(UVE550AR, UVE630AR, UVE750AR)	4
46	19.8	10.7	12.65	29.36	8.5	6	M10	—	—	—	PW-06	1
53.2	21.6	12.9	14.24	34.14	9.5	7.4	M12	—	—	—	PW-08	1
68.45	27.4	17	19	44.45	12	10	M16	—	—	—	PW-10, PW-12	1
32	36	29.5	25.5	32	32	19	M20	42	—	—	UB450K, UB560K	4
—	44	44	30	32	36	26	M24	52	—	—	UB630K, UB710K	4



CHUCK

Hard Jaws for Scroll Chuck HBS series

Description of Model **HBS06C**

- Chuck type
C=JN
- Chuck sizes
- Hard jaw of scroll chuck



Combination Table for Hard Jaws

Hard jaw type	Adaptive chuck model
HBS06C	JN06T, JN06RA5
HBS07C	JN07T, JN07RA5, JN08RA6
HBS09C	JN09T, JN09RA6
HBS10C	JN10T, JN10RA6 (8)
HBS12C	JN12T, JN12RA6 (8)

Dimensional Drawings

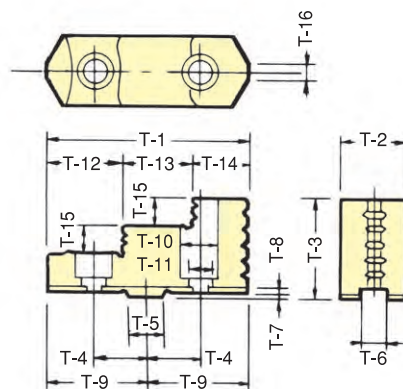
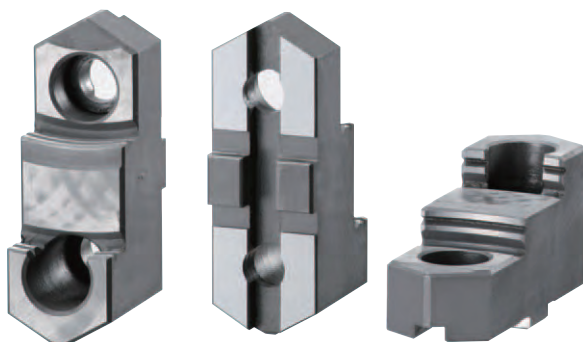

Dimensions

TYPE	Chuck size	T-1	T-2	T-3	T-4	T-5	T-6	T-7	T-8	T-9	T-10	T-11	T-12	T-13	T-14	T-15	T-16	Mounting bolt
HBS06C	6	68	26	37	19.05 ^{+0.1}	12.68 ^{+0.008} _{-0.003}	7.94 ^{+0.05} ₀	3	3.5	34	14	8.5	26	21.5	20.5	8.5	2	M 8 × 20
HBS07C	7	80	28	40	22.225 ^{+0.1}	12.68 ^{+0.008} _{-0.003}	7.94 ^{+0.05} ₀	3	3.5	40	17	11	30.5	26	23.5	9.5	2	M10 × 20
HBS09C	9	90	32	48	26.99 ^{+0.1}	19.03 ^{+0.009} _{-0.004}	12.7 ^{+0.05} ₀	3	3.5	45	19	13	34	30	26	12	3	M12 × 25
HBS10C	10	100	35	52	26.99 ^{+0.1}	19.03 ^{+0.009} _{-0.004}	12.7 ^{+0.05} ₀	3	3.5	50	19	13	38	32	30	14	3	M12 × 25
HBS12C	12	115	40	54	31.75 ^{+0.1}	19.03 ^{+0.009} _{-0.004}	12.7 ^{+0.05} ₀	3	3.5	57.5	19	13	46	35	34	15	4	M12 × 25



CHUCK

Soft Jaws for Scroll Chuck

SBS series

Description of Model **SBS06**

Chuck sizes
Soft jaw of scroll chuck



Combination Table for Soft Jaws

Soft jaw type	Adaptive chuck model	Old chuck model
SBS03	SC-3F	
SBS04	SC-4F	
SBS05	SC-5F	SK-6, KA5-165, KA5C-6
SBS06	JN06T, JN06RA5	SK-7, KA6-190, KA6C-200, KA6C-8
SBS07	JN07T, JN07RA5, JN08RA6, JT07	SK-9, KA6-230
SBS09	JN09T, JN09RA6, JT09	SK-10, KA6 (8) -270, KA6 (8) C-10
SBS10	JN10T, JN10RA6 (8)	SK-12, KA6 (8) -310, KA6 (8) C-12
SBS12	JN12T, JN12RA6 (8)	



Dimensional Drawings

SBS03, SBS04, SBS05

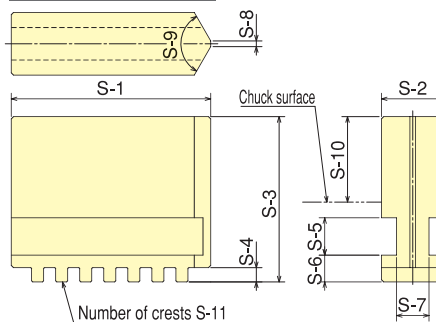

SBS06, SBS07, SBS09, SBS10, SBS12

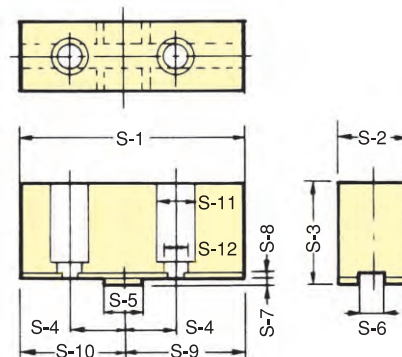

Dimensions

TYPE	Chuck size	S-1	S-2	S-3	S-4	S-5	S-6	S-7	S-8	S-9	S-10	S-11	S-12	Mounting bolt
SBS03	3	35	11	29	2.5	6.55	4.7	5.7	1	120°	15	7		
SBS04	4	42	14	34.5	3.5	6.55	6.2	7.2	1.5	120°	18	7		
SBS05	5	50	16	40	4	8.2	7.7	7.2	1.5	120°	20	7		
SBS06	6	75	26	38	19.05 ^{±0.1}	12.68 ^{+0.008/-0.003}	7.94 ^{+0.05/0}	3	3.5	41	34	14	8.5	M 8 × 20
SBS07	7	88	28	41	22.225 ^{±0.1}	12.68 ^{+0.008/-0.003}	7.94 ^{+0.05/0}	3	3.5	48	40	17	11	M10 × 20
SBS09	9	100	32	48	26.99 ^{±0.1}	19.03 ^{+0.009/-0.004}	12.7 ^{+0.05/0}	3	3.5	55	45	19	13	M12 × 25
SBS10	10	110	35	52	26.99 ^{±0.1}	19.03 ^{+0.009/-0.004}	12.7 ^{+0.05/0}	3	3.5	60	50	19	13	M12 × 25
SBS12	12	125	40	54	31.75 ^{±0.1}	19.03 ^{+0.009/-0.004}	12.7 ^{+0.05/0}	3	3.5	67.5	57.5	19	13	M12 × 25



CHUCK

Back Plate

■ Back Plate Acceptable table

Model	Nose	5	6	8	11	15
B-200	6	CB-06A05				
	8		CB-08A06			
	10		CB-10A06	CB-10A08		
	12		CB-10A06	CB-10A08		
	15			CB-15A08	CB-15A11	
B	15			CB-15A08	CB-15A11	
	18				CB-18A11	
	21					CB-21A15
	24					CB-21A15
BB200	6	CB-06A05				
	8		CB-08A06			
	10		CB-10A06	CB-10A08		
	12		BB212A600	CB-15A08		
BS300	6	BS306A500				
	8		BS308A600			
	10		BS310A600	BS310A800		
BL200	6	CB-06A05				
	8		CB-08A06			
	10		CB-10A06	CB-10A08		
	12		CB-10A06	CB-10A08		
QB300	6	CB-06A05				
	8		CB-08A06			
	10		CB-10A06	CB-10A08		
	12		CB-10A06	CB-10A08		
BT200	6	CBT06A05				
	8		CBT08A06			
	10		CBT10A06	CBT10A08		
	12		CBT10A06	CBT10A08		
BLT200	6	CBT06A05				
	8		CBT08A06			
	10		CBT10A06	CBT10A08		
	12		CBT10A06	CBT10A08		
N	6	CB-06A05				
	8		CB-08A06			
	10		CN-10A06	CB-10A08		
	12		CN-10A06	CB-10A08		
	15			CN-15A08	CB-15A11	
	18			CN-15A08	CB-15A11	
	21			CN-21A08	CN-21A11	CB-21A15
	24				CN-21A11	CB-21A15
NL	6	CB-06A05				
	8		CB-08A06			
	10		CN-10A06	CB-10A08		
	12		CN-10A06	CB-10A08		
	18			CN-15A08	CB-15A11	
ML	6	CB-06A05				
	8		CB-08A06			
NT	15			CBT15A08	CBT15A11	
NLT	6	CBT06A05				
	8		CBT08A06			
	10		CNT10A06	CBT10A08		
	12		CBT10A06	CBT10A08		
MLT	6	CBT06A05				
	8		CBT08A06			
MLV	6	CBT06A05				
	8		CBT08A06			



CHUCK

Chuck Bung

■ Dimensional Drawings

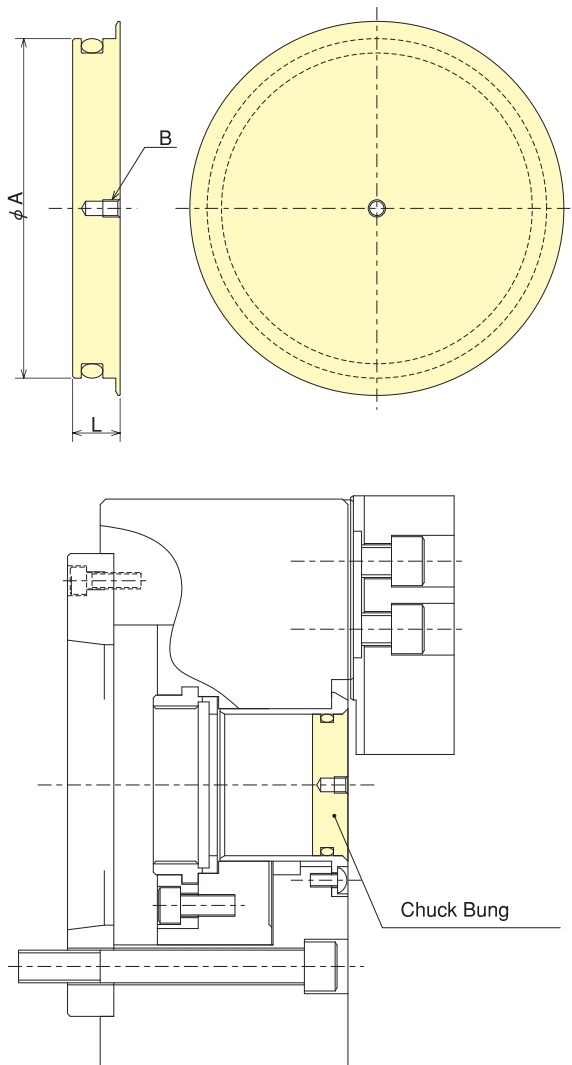

■ Dimensions

Chuck Model	Dimension			O-ring
	A	L	B	
B-15	117.5	16.5	—	P105
B-18	117.5	15	M6	P105
B-21	140	15	M6	P130
B-24	165	15	M6	G155
B-28	195	15	M6	G185
B-204	26	9	M5	P22
B-205	33	12	M5	P26
B-206	45	13	M6	P38
B-208	52	13	M6	P46
B-210	75	15	M6	P65
B-212	91	15	M6	P80
B-215	100	17	M6	P90
BB206	53	13	M6	P46
BB208	66	15	M6	P56
BB210	81	15	M6	P71
BB212	106	15	M6	P95
BL206	28	12	M5	P22A
BL208	45	13	M6	P38
BL210	53	13	M6	P46
BL212	63	15	M6	P53
BS306	45	13	M6	P38
BS308	52	13	M6	P46
BS310	75	15	M6	P65



CHUCK

Chuck Grease **CHUCK GREASE PRO**

Chuck Gripping Force 1.5 times
(Compared to Standard Grease)

Service Life 3 times
(Compared to Standard Grease)



- Conforms to international standards for health, safety and the environment
- Loss of grip over time is reduced
Refer to graph below for B206 chuck.
- White grease is cleaner and reduces contamination
- Various sizes available; 18kg can, 1kg can, 400g bellows and 400gDIN cartridge



Chuck Grease Pro has been specially developed by Kitagawa by utilising long term experience in many applications.

The use of Chuck Grease Pro will extend life, increase gripping force and improve safety.

Fig.1 Gripping force check by grease

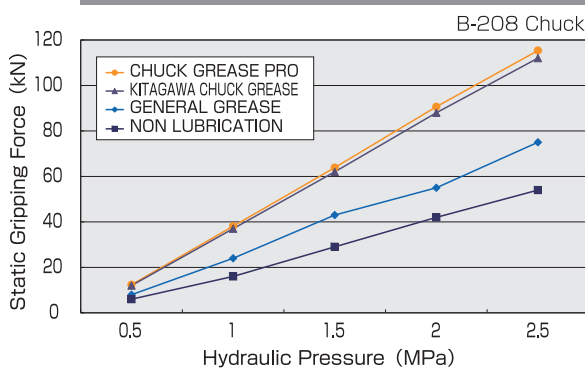
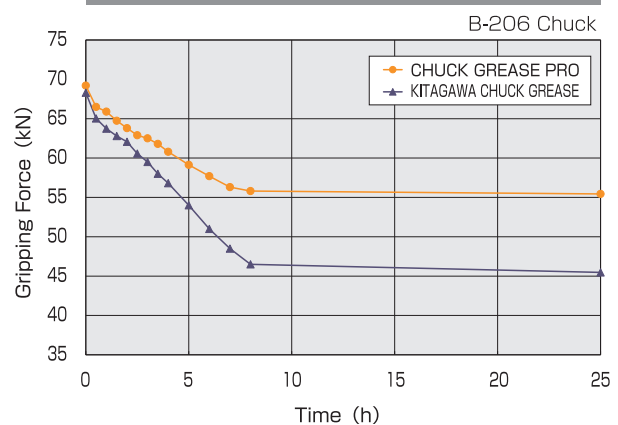

Fig.2 Grease Check Test



※The graphs show the grease performance, not the condition of using Chuck. Please refer to Chuck specification table for the condition of Chuck.

■ Using method

Grease the chuck with a commercial grease gun according to the instruction manual of the chuck as well as general grease.

■ Features

Color	Lemon yellow ~ yellow paste form
Density g/cm ³	1.12
Temperature range °F (°C)	18~300 (-28~149)
Friction factor	0.06~0.1 (by LFW-1 Rotary Reciprocating Test Machine)
NLGI Consistency	#2
JIS K-2220 PS consistency	Mixing 60 times 265-295



CHUCK

Chuck Grease GREASE NIPPLE

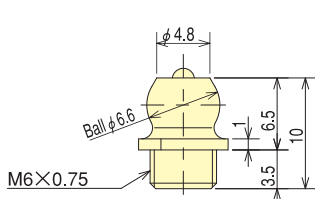

61S403879

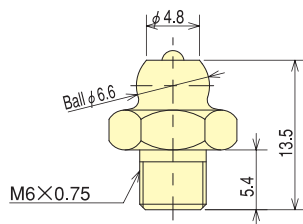

A M6

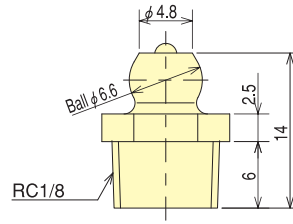

WA-100

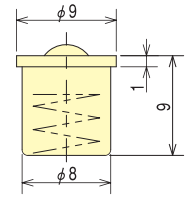

Ball cup 8.0

Grease nipple details

Model	Counterbore dia.	Grease nipple type (DWG No.)	Model	Counterbore dia.	Grease nipple type (DWG No.)
B-204	φ12	61S403879	UVE200K	φ12	A M6
B-205	φ12	61S403879	UVE250K	φ12	A M6
B-206	φ15	A M6	UVE315K	φ12	A M6
B-208	φ15	A M6	UVE400K	φ12	A M6
B-210	φ15	A M6	UB series	φ15	WA-100
B-212	φ15	A M6	UBR series	φ15	WA-100
B-215	φ15	A M6	KPC series	M5 (Body)	M5
B series	φ15	A M6	DL06	φ15 (Body)	61S403879
BB200 series	φ15	61S403879	DL08	φ15 (Body)	A M6
BS306	φ15	61S403879	DL10	φ15 (Body)	A M6
BS308	φ15	A M6	DL12	φ15 (Body)	A M6
BS310	φ15	A M6	PW series	φ15 (Body)	A M6
BL200 series	φ21 (Body) φ15 (Lever)	A M6	PWT series	φ15 (Body)	A M6
HOH-206	φ15 (Body) φ15 (Lever)	61S403879	PUB series	φ15 (Body)	A M6
HOH-208	φ15 (Body) φ17 (Lever)	61S403879, A M6	PU203	φ12 (Body)	A M6
HOH-10K	φ15 (Body) φ17 (Lever)	A M6	PU204	φ15 (Body)	A M6
HOH-12K	φ15 (Body) φ19 (Lever)	A M6	PU205	φ15 (Body)	A M6
HOH-15K	φ15 (Body) φ21 (Lever)	A M6	PU206	φ15 (Body)	A M6
QB306	φ15	61S403879	PU208	φ15 (Body)	A M6
QB308	φ15	A M6	PU210	φ15 (Body)	A M6
QB310	φ15	A M6	PU212	φ15 (Body)	A M6
QB312	φ15	A M6	PUE series	φ15 (Body)	A M6
BT204	φ12	61S403879	LU series	φ15 (Body)	A M6
BT205	φ12	61S403879	FGT05/FG05	φ12 (Body) φ12 (Finger bushing)	A M6
BT206	φ15	A M6	FGT06/FG06	φ15 (Body) φ12 (Finger bushing)	A M6
BT208	φ15	A M6	FGT08/FG08	φ15 (Body) φ15 (Finger bushing)	A M6
BT210	φ15	A M6	FGT10/FG10	φ15 (Body) φ15 (Finger bushing)	A M6
BT212	φ15	A M6	FGT12/FG12	φ15 (Body) φ15 (Finger bushing)	A M6
BLT206	φ21 (Body) φ15 (Lever)	A M6	FG-V series	φ15 (Plunger)	A M6
BLT208	φ21 (Body) φ15 (Lever)	A M6	FG-L series	φ15 (Plunger)	61S403879
BLT210	φ24 (Body) φ15 (Lever)	A M6	FG48MR	Filling type in assembling	Filling in spherical surface part
BLT212	φ26 (Body) φ15 (Lever)	A M6	FG52M	φ15 (Plunger)	61S403879
N-04	φ15	A M6	FG-Q series	φ14 (Plunger)	A M6
N-05	φ15	A M6	SC-3(F)	Ball cup	Ball cup 8.0
N-06	φ15	A M6	SC-4(F)	Ball cup	Ball cup 8.0
N-08	φ15	A M6	SC-5(F)	Ball cup	Ball cup 8.0
N-10	φ15	A M6	JN06	φ15 (Body)	61S403879
N-12	φ15	A M6	JN07	φ15 (Body)	61S403879
N-15	φ15	A M6	JN09	φ15 (Body)	61S403879
N-18	φ15	A M6	JN10	φ15 (Body)	61S403879
N-21	φ15	WA-100	JN12	φ15 (Body)	61S403879
N-24	φ15	WA-100	SC-14	Ball cup	Ball cup 8.0
NLO4	φ15	A M6	SC-16	Ball cup	Ball cup 8.0
NLO6	φ15	A M6	JN..T series	φ15 (Body)	61S403879
NLO8	φ15	A M6	JN..RA series	φ15 (Body)	61S403879
NL10	φ15	A M6	JT series	φ15 (Body)	61S403879
NL12	φ15	A M6	JS series	φ15 (Body)	61S403879
NL18	φ15	A 01	AS04	φ15 (Body)	61S403879
ML series	φ21 (Body) φ15 (Lever)	A M6	AS06	φ15 (Body)	A M6
NT series	φ15	A M6	AS08	φ15 (Body)	A M6
NLT series	φ15	A M6	AS10	φ15 (Body)	A M6
MLT series	φ21 (Body) φ15 (Lever)	A M6	AT04	φ15 (Body)	61S403879
MLV series	φ21 (Body) φ15 (Lever)	A M6	AT06	φ15 (Body)	A M6
HW-08	φ24 (Body)	A M6	AT08	φ15 (Body)	A M6
HW-10	φ26 (Body) φ14 (Lever)	A M6	AT10	φ15 (Body)	A M6
HW-12	φ26 (Body) φ14 (Lever)	A M6	PLS series	φ15 (Body)	A M6
HW-15	φ40 (Body) φ17 (Lever)	A M6	JM200	φ15 (Body)	A M6
UVE160K	φ12	A M6	SC-S series	Ball cup	Ball cup 8.0



CHUCK

Stationary Gripping Meter JFT-S100

Gripping force can be checked at a glance!

Compact design with excellent workability
Chuck gripping force is quantified, thus improving quality control and safety!

- **Compact and integral**
Integrated detector and display. Easy to handle with a low weight of only 1.3kg!
- **Zero adjustment NOT required**
Enables quick measurement with the automatic zero adjustment function!
- **Measured value memory function**
Stores three required measured values, and enables later checking.
- **Power-saving function**
Saves power with the automatic power-off function.
- **Battery voltage drop, excessive input, out-of-range zero adjustment, etc.**



The calibration certificate for ISO-9001 can be issued (option)

Dimensional Drawings

When the number of gripping points is 3.

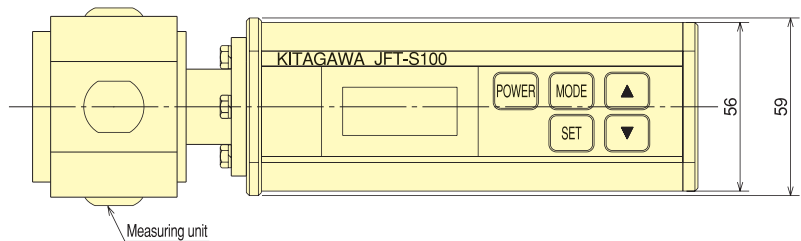
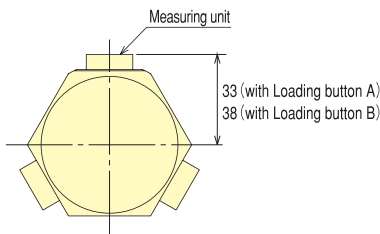

When the number of gripping points is 2.

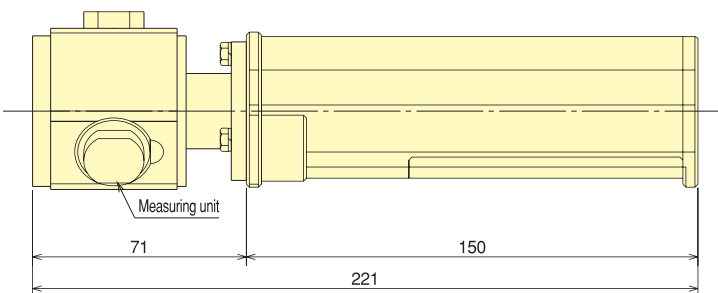
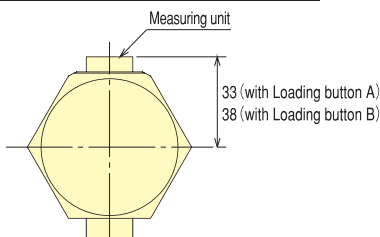

Specifications

Loading Cell	
Constant Capacity(per jaw)	100 kN
Allowable load	150 %
Gripped points	Two or three positions
Accuracy	±2 % R.O.
Measurable diameter	φ62~φ65mm (with Loading button A) φ62~φ75mm (with Loading button B)

Display	
Measuring range	0.5~100 kN
Max. Display	110.0 kN
Display unit	0.1 kN
Operation Switch	Sheet Switch Panel
Display unit	LCD Character display (8×2 line with Back light)

Others	
Power	Lithium Battery (CR123A)×2sets
Operation Temperature	0~50°C
Operation Humidity	80%RH or less
Weight	1.3 kg
Accessory	Loading button A (H 7mm)×3pieces Loading button B (H 12mm)×3pieces Battery for operation check (CR123A×2pieces)



CHUCK

Compatibilities of Lathes to Short Taper Chucks

	Model	First Spindle	Second Spindle		
		Nose (JIS)	Nose (JIS)		
AMADA MACHINE TOOLS	L	3-J2,3-J3	A1-6	—	
		5-J2,5-J3	A2-8	—	
		6-J	A1-11	—	
		7-J	A2-11	—	
		12-C,15-C	A1-8	—	
		LE(G)	19K	A1-6	—
		LEO(G)	80A,125A	A1-6	—
		LG	5,6,7,7M	A2-4	—
			7F,8,8M,8MC	A2-6	—
		LJ	3A	A2-4	—
	3B,5B		A2-6	—	
	6,10,6M(MC),10M(MC)		A2-8	—	
	LN	32N,50N	A1-6	—	
	LPT	35C	A1-5	—	
	LR	55A	A1-5	—	
	SH	5 (M,D,DM)	A2-4	—	
	SL	10,10S	A2-6	—	
		12	A2-8	—	
	TH	5 (M)	A2-4	—	
		10 (M)	A2-6 (at special A2-4)	—	
	G	04T,04-UP	Special	—	
		05-UP	φ95 Flat	—	
		05,06,07,07-M	φ100 Flat	—	
		G-5	φ80 Flat	—	
		07-F	A2-6	—	
	J	1	φ100 Flat	—	
		f-1,J-1	φ80 Flat	—	
		3	A2-6	—	
		5	A2-6/A2-8	—	
	A	18,18f	φ56 Flat/φ80 Flat	—	
		12,D-12	A2-6	—	
		18-S,D-18S	A2-8	—	
	IKEGAI	AN	20N	A2-6	—
			25N	A2-8	—
			30N	A2-8	—
		AX	40B	A2-15	—
			EC18	A1-5	—
		ED18	A1-5	—	
		FT	20	A2-6	—
			20U,25U,20J,25J,600	A2-8	—
		FX	10N	A1-5	—
			15N,MINI	Straight, plate	—
			20N	A1-6	—
			20II	A2-6	—
			25W,25II	A2-8	—
LX20N			A1-6	—	
TC		8,10	Straight, plate	—	
	15	A2-6	—		
TCR	25	A2-8	—		
	25,25Y	A2-8	—		
TU	15	A2-6	—		
TUR	15	A2-6	—		
TM25YS	Sub	A2-6	—		
	Maine	A2-8	—		
OKUMA	LB	2000EX	φ140 Flat (A2-6)	φ140 Flat	
		2500EX	A2-6	—	
		3000EX	A2-6(A2-8,A2-11)	φ140 Flat	
		4000EX	A2-8(A2-11)	—	
		35II	A2-8(A2-11,A2-15)	—	
		45II	A2-11 (A2-20)	—	
	LU	300	φ140 Flat (A2-6,A2-8)	—	
		400	A2-8(A2-11)	—	
		35	A2-8(A2-11,A2-15)	—	
		45	A2-11 (A2-20)	—	
	LCS	250	A2-6(A2-8)	—	
		25	A2-8	—	
	2SP	150H	φ140 Flat	—	
		250H	A2-6	—	
		10HG	φ140 Straight	φ140 Straight	
		25HG	A2-6	A2-6	
		35HG,V40	A2-8	A2-8	
		V60,V80	A2-11	A2-11	
	LFS	10-2SP	φ140 Straight	φ140 Straight	
		10M-2SP	φ140 Straight	φ140 Straight	
	3SP	25HG	A2-6	A2-6	
		LVT	300	A2-6	—
	LAW	400	A2-8	—	
		VI,2S	A2-8	—	
	MAC TURN	V24	A2-11	—	
		250	A2-6(A2-8)	φ140 Flat (A2-6)	
		350	A2-6(A2-8)	φ140 Flat (A2-6,A2-8)	
		550	A2-8(A2-11)	A2-8	

	Model	First Spindle	Second Spindle	
		Nose (JIS)	Nose (JIS)	
OKUMA	MULTUS	B200	φ140 Flat	—
		B200(W)	φ140 Flat	φ140 Flat
		B300	A2-6(A2-8)	—
		B300(W)	A2-6(A2-8)	A2-6
		B400	A2-8(A2-11)	—
	LT	B400(W)	A2-8(A2-11)	A2-8
		200-M	φ140 Flat (A2-6)	φ140 Flat (A2-6)
		300-M	A2-6(A2-8)	A2-6(A2-8)
	LOC	650	A2-15(A2-20,φ725 Flat)	—
	LH(※)	55-N	A2-11(A2-15,A2-20)	—
	HJ	18	φ140 Straight	—
		28,250	A2-6	—
	HL	20	A2-6	—
		35(L)	A2-8	—
	SV	250	φ140 Flat	—
40R		A2-8	—	
V	60R,80R	A2-11	—	
	100R	φ380 Flat	—	
VTM	70	A2-11	—	
	65,100,80YB,120YB	A2-11	—	
※Mounting bolts of LH are unifying specifications. Numerical values in () are large diameter as option.				
KITAKO	ACE		A2-6	—
	HS	4200	A2-6	—
	mini ACE		A2-5	—
	MT4	75,80,80-200,85	φ60 Straight	—
		120,120G,125	A2-5	—
		170,200,250S	A2-6	—
	MT3	120	A2-5	—
		200	A2-6	—
	TG1	52	A2-6	—
	TM1	52	A2-6	—
	V	5 II,Turn	A2-6	—
	VT1	200	A2-6	—
	400,500	A2-8	—	
VT2	500	A2-8	—	
VT4	200	A2-6	—	
	350,450,550	A2-8	—	
DANICHIKINZOKU KOGYO	B70		A2-11	—
	DGL	6,8,10	A1-6	—
	DHK,DHM,N105,SH		A1-11	—
	DLG	SH	A1-6	—
		SHB	A1-11	—
	DM		A1-11	—
		III	A2-11	—
	F	15	A2-5	—
		20	A2-6	—
		25	A1-6	—
		30,35	A2-8	—
	M95		A1-11	—
MC	112,132,152	A2-15	—	
TAL	460,510	A1-6	—	
	600	A1-8	—	
TC	100	Straight φ140	—	
	200	A2-6orStraightφ140	—	
	350	A2-8	—	
	40	A2-11	—	
TAKIZAWA	TK	2	A2-6	—
	TAC	360	A1-5	—
		510,650	A2-8	—
		780	A2-11	—
		950	A2-11	—
	TSL	550,800	A1-5	—
	TT	160	Straight φ140	—
		200	A2-6	—
	TMM	250	A2-8	A2-6
		200	A2-6	A2-6
TNR	200	A2-6	A2-6	
OHBUKI	LLA	800,1000,1500,2000,2500,3000	A2-8	—
	CLL	1000,1500,2000,2500,3000	A2-11	—
TSUGAMI	PAN	1,2	Straight, plate	—
	NCM	45/160,70/160	Straight, plate	—
	NL	1	A1-6	—
NAKAMURA	1H		A1-5	—
	TMC	12	A2-5	—
		18	A2-6	—
	TMY	25	A2-6	—
	SC	150 II	A2-5	—
	200	A2-6	—	
	250	A2-8	—	
	300	A1-8	—	
	450	A2-8	—	

Model		First Spindle	Second Spindle	
		Nose (JIS)	Nose (JIS)	
NAKAMURA	TW	8	Straight ϕ 108	
		10	A2-5	
		20	A2-6	
		30	A1-8	
	WT	100	A2-5	
		150	A2-5	
		250A	A2-6	
		250B	A2-5	
		250C	A2-5	
		300	A2-6	
	STW/STS	40	A1-8	
	WTW/WTS	150 Big bore	A2-6 ϕ 65	A2-5 ϕ 51
		150 Big bore	A2-5 ϕ 51	A2-5 ϕ 42
		150A	A2-5 ϕ 42	A2-5 ϕ 42
		150B	A2-5 ϕ 32	A2-5 ϕ 32
	NTX-W	ϕ 61	A2-6	
	NTX-S	ϕ 71	A1-8	
	NTJ	ϕ 51	A2-5	
		ϕ 65	A2-6	
	NTM3	ϕ 51	A2-5	
	NTY3		A2-5	
	NTJX	ϕ 51	A2-5	
		ϕ 65	A2-6	
	SUPER TURN	2AM	A2-5	—
2BM		A1-8	—	
3		A1-6	—	
4		A1-8	—	
5		A1-8	—	
6		A1-11	—	
MIYANO	ABX	51SY,51TH2	A2-6	
		64SY,64TH2	A2-8	
	BNC	34C5,42C5	Straight, plate	—
	BND	34C5,42C5	Straight, plate	—
		34S5,42S5	Straight, plate	—
		51C2	A2-6(Enlarged:A2-8)	—
	BNE	51S2,51SY2	A2-6(Enlarged:A2-8)	Straight, plate
		34S5,34SY5	Straight, plate	Straight, plate
	BNJ	51S,51SY5	A2-6	Straight, plate
		34S,34SY	Straight, plate	Straight, plate
	BX	42S,42SY	Straight, plate	Straight, plate
		51S,51SY2	A2-6(Enlarged:A2-8)	Straight, plate
		20S,26S	Straight, plate	Straight, plate
	LX	06E2	Straight, plate	—
		08C,08R	Straight, plate	—
	LZ	08E2	A2-6	—
		01R2,01RY2	Straight, plate	—
	GN	02R2,02RY2	A2-6	—
3200,3000,4		Straight, plate	—	
3000W,3100W		Straight, plate	Straight, plate	
	BM250	Straight, plate	Straight, plate	
MURATA	MW	100G(HG),120G(HG)	A2-5	
		200G	A2-6	
		200GS	A2-8	
		300G	A2-8	
		400G	A2-11	
	MS	50G,60G	A2-5	—
		100G	A2-6	—
	MZ	60G	Flat	—
	MD	60G	A2-5	—
		100G	A2-6	—
		120G	A2-5	A2-5
	MT	200G	A2-6	A2-6
12		A2-5	A2-5	
MV	20,25	A2-6	A2-6	
	120(M)	A2-5	—	
WSC	6	Straight, plate	—	
	12	A2-5	—	
1SC	10M5000	A2-6	—	
	12M5020	A2-8	—	
MSC	22	A2-8	—	
	2SC	15M5060,18M5090	A1-11	—
3SC	24(M5240),28	A1-15	—	
MORI SEIKI	CL	1500	A2-5	
		2000A,2000B(Large bore spec)	A2-6	
	Dura Turn	1530	A2-5	—
		2030	A2-6	—
		2050	A2-6	—
		2550	A2-8	—
	MT		A2-5	—
		(Large bore spec)	A2-6	—
		With 2nd main spindle	A2-5	A2-5
		With 2nd main spindle(Large bore spec)	A2-6	A2-5
		2000	A2-6	—
		2000(With 2nd main spindle)	A2-6	A2-5
		2500,3000	A2-8	—
		2500(With 2nd main spindle),3000(With 2nd main spindle)	A2-8	A2-6
		4000A Type	A2-11	—
4000B Type		A2-15	—	
4000C Type		A1-20	—	
4000A Type(With 2nd main spindle)		A2-11	A2-8	
4000B Type(With 2nd main spindle)		A2-15	A2-8	

Model		First Spindle	Second Spindle
		Nose (JIS)	Nose (JIS)
MORI SEIKI	MT	4000C Type(With 2nd main spindle)	A1-20
	NL	1500	A2-5
		1500(With 2nd main spindle)	A2-5
		2000	A2-6
		2000(With 2nd main spindle)	A2-6
		2500,3000	A2-8
		2500(With 2nd main spindle)	A2-8
	NT	3100,3150	A2-5
		3100(With 2nd main spindle),3150(With 2nd spindle)	A2-5
		3200,4200	A2-6
		3200(With 2nd main spindle),4200(With 2nd spindle)	A2-6
		4250,4300	A2-8
		4250(With 2nd main spindle),4300(With 2nd spindle)	A2-8
		5400	A2-11
		5400(With 2nd main spindle)	A2-11
		6600B	A2-15
		6600B(With 2nd main spindle)	A2-15
	NZ	6600C	A1-20
		6600C(With 2nd main spindle)	A1-20
		1500	A2-5
	NZ-S	2000	A2-6
		1500	A2-5
	RL	1500(Large bore spec)	A2-6
		153	A2-5
203		A2-6	
SL	2500	A2-8	
	154	A2-5	
	154(With 2nd main spindle)	A2-5	
	204	A2-6	
	204(With 2nd main spindle)	A2-6	
	2500Y,303A,303B(Large bore spec)	A2-8	
VL	403B,65B,65MC	A2-11	
	403C,603B,803A,80A,80F	A2-15	
	603C,65C,803B,80,80B	A1-20	
	65A,75A	A1-11	
	803C,80C	A2-20	
	1000	A2-5	
	253A1	A2-8	
	553	A2-11	
	ZL	153	A2-5
		153(With 2nd main spindle)	A2-5
203,253(High speed spec.)		A2-6	
203(With 2nd main spindle)		A2-6	
253,35		A2-8	
ZT	253S	A2-8	
	45B,45MC	A2-11	
	1000Y,1500Y	A2-5	
	1500YB	A2-6	
	1500YB(With 2nd main spindle, Large bore spec)	A2-6	
MAZAK	CT	2500	A2-8
		S1500	A2-5
		S1500(Large bore spec)	A2-6
	DT	4500	A2-11
		5500	A2-20
	INTE	20	A2-6
		25	A2-8
		1004	A2-5
		1004S	A2-5
		2004	A2-6
		2004S	A2-6
		30,044,004	A2-8
3004S,4004S		A2-8	
410H2,410H2 Option spec.,420H2		A2-8	
410HS2,410HS2 Option spec.,420HS2		A2-8	
420H2 Option spec.,500H2,650H2	A2-11		
420HS2 Option spec.,500HS2,650HS2	A2-11		
500H2 Option spec.,650H2 Option spec.	A2-15		
500HS2 Option spec.,650HS2 Option spec.	A2-15		
IVS	200	A2-6	
	300	A2-8	
	400	A2-11	
M	4	A2-8	
	5	A2-11	
MP	6100	A2-5	
	4200,6200	A2-6	
	4300,6250,6300,650	A2-8	
MPN	8200Y	A2-6	
NANO TURN		ϕ 85h6 Flat	
PM		A1-11	
QTN	100	A2-5	
	100S	A2-5	
	150,200	A2-6	
	200S	A2-6	
	250	A2-8	
	300	A2-8	
	350,400	A2-11	
450	A2-15		
ST	450,50	A1-11	
	60	A2-15	
	80	A2-11	



CHUCK

For mounting a short taper chuck to lathe spindle end

●About lathe spindle end

Standards covering the lathe spindle end are stipulated in ISO, ASA, DIN, etc except JIS.

Japan major lathe manufacturers manufacture the great majority of lathe spindle end parts at standards of JIS-A1, A2 (ISO-A1, A2). However, a part of lathe spindle end parts is manufactured at ASA-A1, A2.

Although the spindle end dimensions according to each standard are the same, the dimensional tolerance of a face plate (chuck or back plate) varies by a few microns.

●Mounting the short taper (direct type) chuck for spindle end

The taper diameter of the short taper chuck for the spindle end is small slightly and the chuck has the some amount of interference (tolerance). A little gap occurs in mutual mounting end faces when the chuck is set. The chuck is closely touched by screwing mounting bolts. (The face having mounting bolt holes is the mounting face.) Tighten the chuck evenly by screwing bolts diagonally.

When interference (tolerance) of the chuck is large or small, any gap may occur in diameter direction. In the former case, the chuck may be deformed at the time of chuck mounting. In the latter case, a gripping accuracy becomes low for increasing a mounting error.

Similarly, the scroll chuck will also be deformed by tightening it excessively when mounting the chuck to the small end face of spindle end taper. Thus, the handle operation or chuck motion becomes heavy extremely.

Moreover, take care since the more interference, the more failure becomes large.

※See a lathe matching list of the short taper chuck.

When you need taper correction, since correction expense is required separately, please consult our company.

●For order of separate jaw scroll chucks JN..RA for short taper

When placing an order, establish contact with your agent or our company to advise a manufacturer name and type of a lathe used in a customer shop.

Since the dimensional tolerance of spindle end face may vary by manufacturers, it is necessary to correct the taper of the chuck rear body. (Please understand that there is a fluctuation of a delivery date and a price.)

Moreover, JN..RA types are standard and chuck mounting M bolts are packed together with the chuck. Since each chuck mounting bolt is manufactured at inch (UNIH1 bolt or wit screw) by manufacturers, confer with our company.

Nose shape figure

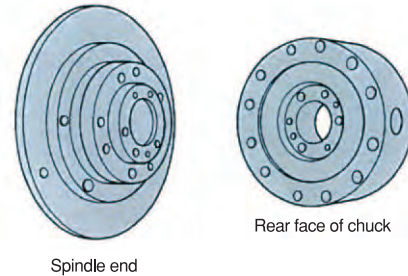

Nose dimension figure

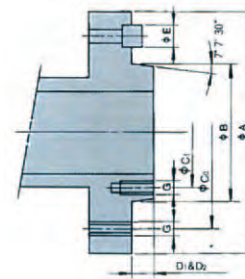

Spindle end and face plate of JIS B 6109 lathe

No.	5-nose	6-nose	8-nose	11-nose	15-nose
A	133	165	210	280	380
B	82.563	106.375	139.719	196.869	285.775
C ₀	104.8	133.4	171.4	235	330.2
C ₁	61.9	82.6	111.1	165.1	247.6
D ₁	14.288	15.875	17.462	19.050	20.638
D ₂	13	14	16	18	19
E	15.88	19.05	23.81	28.58	34.93
G	M10	M12	M16	M20	M22

■Note) D1 is nose A1 and D2 nose A2



For order of Scroll chuck

- For order of hard jaws of scroll chuck [Internal, External & 2 piece jaw (Top and Base jaws)]
 - SC series · · · Bodies of 3, 4, 5, 14 and 16 inches are made of cast iron.
 - JN/JN-T JN..RA series · · · Bodies of 12 -16 inches are made of steel.

In SC series, Hard jaws are ground with the chuck and it is required the tolerance combination on the jaw fitting. As a general rule, Gripping face is ground concentrically in our shop as repair.

In JN series, the tolerance combination is not required but Gripping face is need to be ground concentrically.

In case of Base jaw for the 2 piece jaw chucks(JN-T/JN..RA), the tolerance combination is also required as well as SC type chucks.

At customer's strong demand, only parts will be supplied however, problem may occur, i.e. Accuracy is not satisfied because jaws are not ground with the existing chuck body.

■ Hard Jaw (SC series)

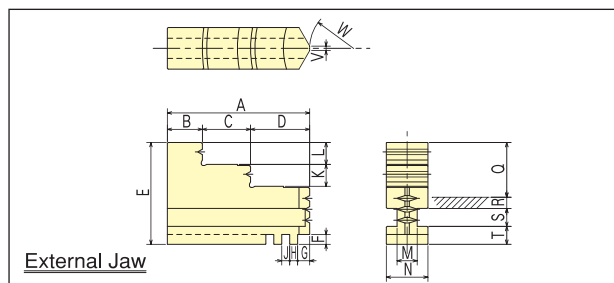
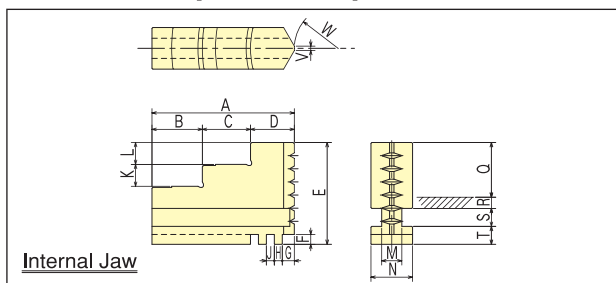

■ SC series Jaw Dimensions

Model		A	B	C	D	E	F	G	H	J	K	L	M	N	Q	R	S	T	V	W
SC-3	Internal jaw	35	14	10	11	29	2.5	4	2.11	2.11	6	6	5.7	11	15	2.75	6.55	4.7	1	R 7.5
	External jaw	35	9	10	16	29	2.5	4	2.11	2.11	6	6	5.7	11	15	2.75	6.55	4.7	1	R 7.5
SC-4	Internal jaw	42	16	13	13	34.5	3.5	4.5	2.54	2.54	7	7	7.2	14	18	3.75	6.55	6.2	1.5	R11
	External jaw	42	10	13	19	34.5	3.5	4.5	2.54	2.54	7	7	7.2	14	18	3.75	6.55	6.2	1.5	R11
SC-5	Internal jaw	50	20	15	15	40	4	4	3.175	3.175	8	8	7.2	16	20	4.1	8.2	7.7	1.5	R15
	External jaw	50	14	15	21	40	4	4	3.175	3.175	8	8	7.2	16	20	4.1	8.2	7.7	1.5	R15
SC-14	Internal jaw	132	49	42	41	93.5	7	8	5.08	5.08	18	18	19	35	52	9.3	16.2	16	5	R47
	External jaw	132	40	41	51	93.5	7	8	5.08	5.08	18	18	19	35	52	9.3	16.2	16	5	R47
SC-16	Internal jaw	146	52	50	44	102	7	10.5	5.08	5.08	20	20	23	40	58	11.8	16.2	16	6	R53
	External jaw	146	43	50	53	102	7	10.5	5.08	5.08	20	20	23	40	58	11.8	16.2	16	6	R53

■ Hard Jaw (JN series)

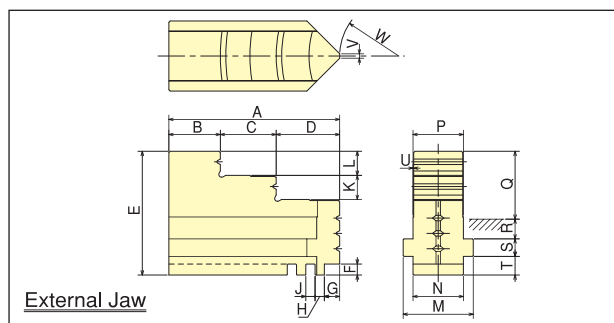
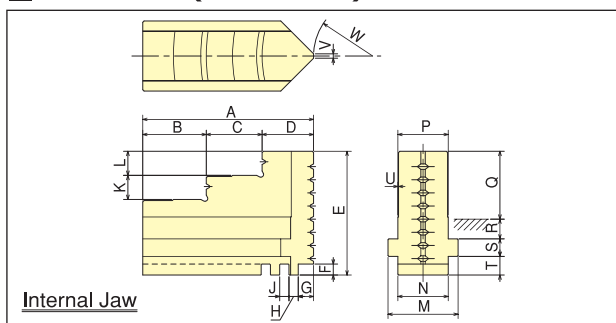

■ JN series Jaw Dimensions

Model		A	B	C	D	E	F	G	H	J	K	L	M	N	P	Q	R	S	T	U	V	W
JN06	Internal jaw	66	26.5	19	20.5	48.5	4.5	5.5	3.629	3.629	9	9	29	21	21	27	8	6.5	7	0.3	2	R19.5
	External jaw	66	18	19	29	48.5	4.5	5.5	3.629	3.629	9	9	29	21	21	27	8	6.5	7	0.3	2	R19.5
JN07	Internal jaw	78	29	25.5	23.5	56.5	5	7	4.233	4.233	11	11	32	23	23	31	9	8	8.5	0.3	2	R27
	External jaw	78	20.5	25.5	32	56.5	5	7	4.233	4.233	11	11	32	23	23	31	9	8	8.5	0.3	2	R27
JN09	Internal jaw	88	34	28	26	62.5	5	7.5	4.233	4.233	13	13	38	27	27	33	10.5	9.5	9.5	0.3	3	R34.5
	External jaw	88	24	28	36	62.5	5	7.5	4.233	4.233	13	13	38	27	27	33	10.5	9.5	9.5	0.3	3	R34.5
JN10	Internal jaw	98	36.5	32	29.5	66.5	5	7.5	4.233	4.233	14	14	38	27	27	37	10.5	9.5	9.5	0.3	3	R42
	External jaw	98	28	32	38	66.5	5	7.5	4.233	4.233	14	14	38	27	27	37	10.5	9.5	9.5	0.3	3	R42
JN12	Internal jaw	113	41.5	36.5	3.5	81	6	8	5.08	5.08	15	15	44	31	31	44	14.5	12	11	0.3	4	R42
	External jaw	113	33	36.5	43.5	81	6	8	5.08	5.08	15	15	44	31	31	44	14.5	12	11	0.3	4	R42

■ Gripping range

Model	Gripping range							
	External gripping					Internal gripping		
	A1	A2	A3	A4	Soft Jaw	B1	B2	Soft Jaw
SC-3 (F)	2~35	33~55	53~70	2~35	(2~70)	24~44	42~64	(24~64)
SC-4 (F)	3~43	41~69	67~95	3~43	(3~95)	29~57	55~84	(29~84)
SC-5 (F)	3~46	44~77	75~110	3~46	(3~110)	33~67	65~100	(33~100)
JN06	3~64	62~112	110~160	3~64	—	48~100	98~150	—
JN06T	3~64	62~112	110~160	—	3~160	55~104	102~150	55~150
JN06R	3~64	62~112	110~160	—	—	55~104	102~150	—
JN07	4~72	70~126	124~180	4~72	—	56~114	112~170	—
JN07T	4~68	66~124	122~180	—	4~180	62~117	115~170	62~170
JN07R	4~68	66~124	122~180	—	—	62~117	115~170	—
JS07	4~72	70~126	124~180	4~72	—	56~114	112~170	—
JT07	—	—	—	—	4~180	—	—	62~170
JN08R	4~76	74~138	136~200	—	—	62~127	125~190	—
JN09	5~84	82~150	150~220	5~84	—	62~137	135~210	—
JN09T	5~80	78~150	148~220	—	5~220	70~141	139~210	70~210
JN09R	5~80	78~150	148~220	—	—	70~141	139~210	—
JS09	5~84	82~152	150~220	5~84	—	62~137	135~210	—
JT09	—	—	—	—	5~220	—	—	70~210
JN10	5~96	94~178	176~260	5~96	—	70~161	159~250	—
JN10T	5~94	92~177	176~260	—	5~260	80~166	164~250	80~250
JN10R	5~94	92~177	176~260	—	—	80~166	164~250	—
JN12	10~108	108~204	202~300	10~108	—	86~189	187~290	—
JN12T	10~108	108~204	202~300	—	10~300	90~191	189~290	90~290
JN12R	10~108	108~204	202~300	—	—	90~191	189~290	—
SC-14	25~118	116~210	208~315	25~118	—	107~188	186~290	—
SC-16	25~132	130~215	213~360	25~132	—	113~212	210~340	—

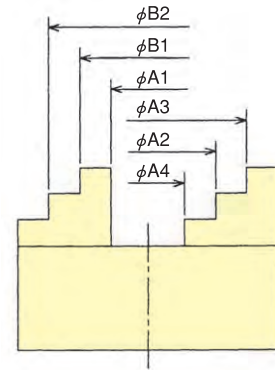

SC (F) / JN / JS type

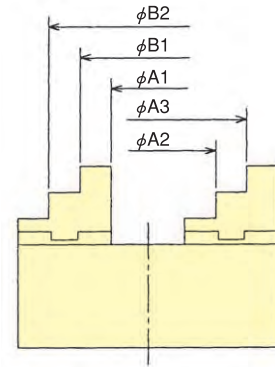

JN.T / JN.R type

■ Chuck handle Dimensions

Model	F1	F2	F3	F4	F5
SC-3	65	15	8	110	7
SC-4	70	17	8	140	8
SC-5	75	20	10	170	8
JN06	120	20	10	210	10
JN07	160	20	12	240	11
JN09	160	22	12	290	12
JN10	160	22	12	360	12
JN12	200	26	16	390	14
SC-14	140	30	16	450	15
SC-16	140	30	16	450	15
IC-4	75	12	8	120	6
IC-6	100	13	8	150	8
IC-8	130	15	10	200	10
IC-10	150	18	12	250	10
IC-12	170	19	14	300	12
IC-14	170	19	14	300	12
IC-16	220	22	16	400	14
IC-18	220	22	16	400	14

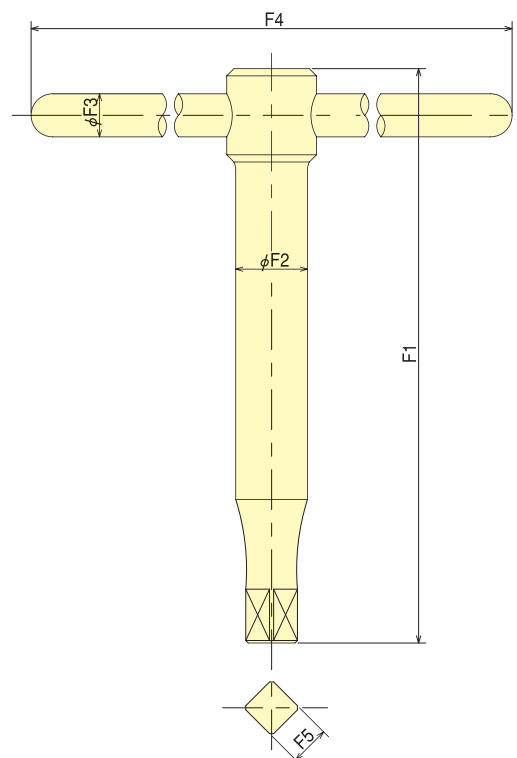



America Contact

KITAGAWA - NORTHTECH INC.
 Tel. +1 847-310-8787 Fax. +1 847-310-9484

301 E. Commerce Dr, Schaumburg, IL. 60173 USA
<http://www.kitagawa.com>

Europe Contact

KITAGAWA EUROPE LTD.
 Tel. +44 1725-514000 Fax. +44 1725-514001
 KITAGAWA EUROPE GmbH
 Tel. +49 2102-123-78-00 Fax. +49 2102-123-78-69
KITAGAWA EUROPE GmbH Poland Office
 Tel. +48 607-39-8855 Fax. +48 32-749-5918
KITAGAWA EUROPE GmbH Czech Office
 Tel. +420 603-856-122 Fax. +420 549-273-246

Unit 1 The Headlands, Downton, Salisbury, Wiltshire SP5 3JJ, United Kingdom
<http://www.kitagawaeurope.com>
 Borsigstrasse 3, 40880, Ratingen Germany
<http://www.kitagawaeurope.de>
 44-240 Zory, ul. Niepodleglosci 3 Poland
<http://www.kitagawaeurope.de>
 Lysicka 3, 621 00 Brno, Czech Republic
<http://www.kitagawaeurope.de>

Asia Contact

KITAGAWA INDIA PVT LTD.
 Tel. +91 20-6500-5981 Fax. +91 20-2615-0588
 KITAGAWA (THAILAND) CO.,LTD. Bangkok Office
 Tel. +66 2-712-7479 Fax. +66 2-712-7481
 KITAGAWA IRON WORKS CO.,LTD. Singapore Branch
 Tel. +65 6838-4318 Fax. +65 6408-3935
 KITAGAWA IRON WORKS (SHANGHAI) CO.,LTD.
 Tel. +86 21-6295-5772 Fax. +86 21-6295-5792
 DEAMARK LIMITED
 Tel. +886 2-2393-1221 Fax. +886 2-2395-1231
 KITAGAWA KOREA AGENT CO.,LTD.
 Tel. +82 2-2026-2222 Fax. +82 2-2026-2113

Lotus House East, Lane 'E' North Main Road, Koregaon Park, Pune 411 001, Maharashtra, India
 9th FL, Home Place Office Building, 283/43 Sukhumvit 55Rd. (Thonglor 13),Klongton-Nua, Wattana, Bangkok 10110, Thailand
 #02-01 One Fullerton, 1 Fullerton Road, Singapore 049213
 Room308 3F Building B. Far East International Plaza, No.317 Xian Xia Road, Chang Ning, Shanghai, 200051 China
<http://www.kiw-sh.com>
 No. 6, Lane 5, Lin Sen North Road, Taipei, Taiwan
<http://www.deamark.com.tw>
 803 Ho, B-Dong, Woolim Lion's Valley, 371-28 Gasan-Dong, Gumcheon-Cu, Seoul, Korea
<http://www.kitagawa.co.kr>

Oceania Contact

DIMAC TOOLING PTY.LTD.
 Tel. +61 3-9561-6155 Fax. +61 3-9561-6705

61-65 Geddes Street, Mulgrave, Victoria, 3170 Australia
<http://www.dimac.com.au>

Japanese speaker available

kitagawa <http://www.mta.kiw.co.jp>

KITAGAWA IRON WORKS CO., LTD.

77-1 Motomachi, Fuchu-shi, Hiroshima-pref. 726-8610, Japan Tel. +81 847-40-0526 Fax. +81 847-45-8911

·Specifications and outside appearance are subject to change without notice due to ongoing research and development.
 ·The color of the actual product may be different from the catalogue's due to printing matters.
 ·Catalogue contents as of 2013.5
 ·The products herein are controlled under Japanese Foreign Exchange and Foreign Trade Control Act.
 In the event of importing and/or exporting the products,
 you are obliged to consult KITAGAWA as well as your government for the related regulation prior to any transaction.