

ENERGY  
2016

## Valves for oil-immersed transformers

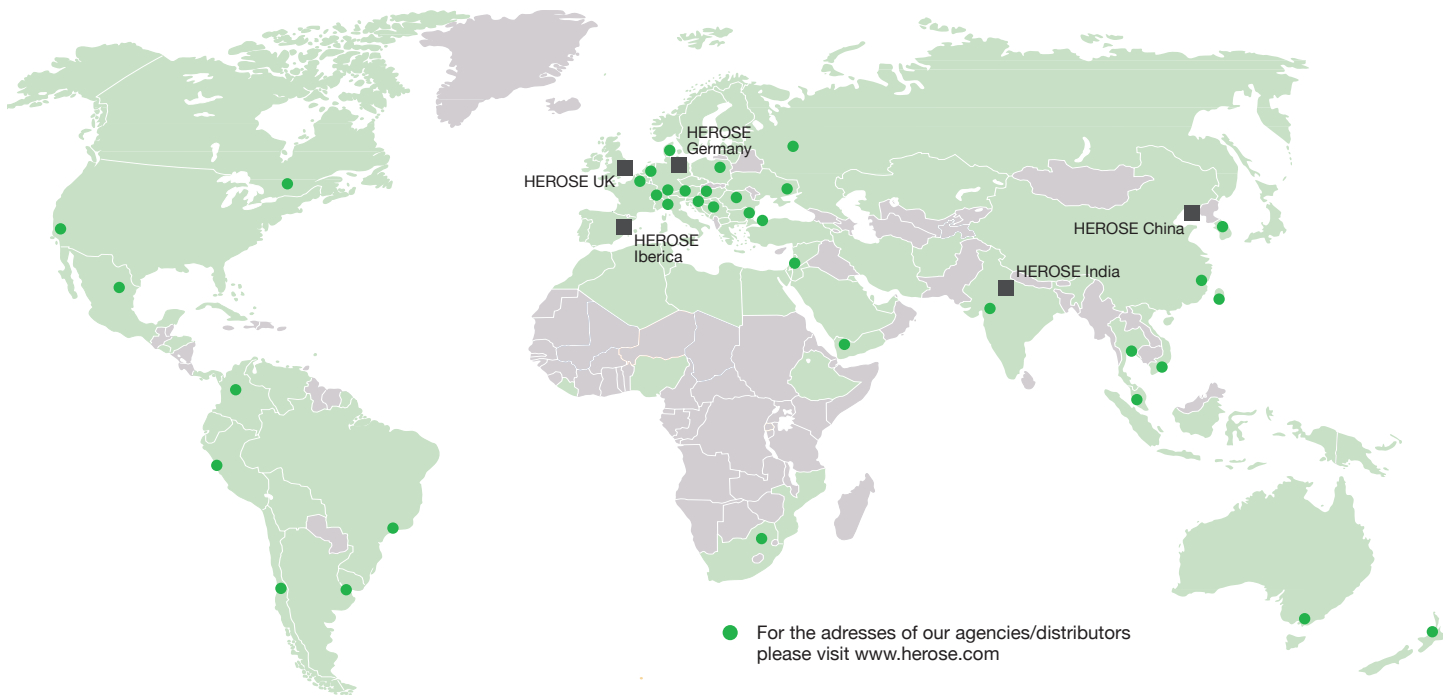



**Headquarter Germany**

**HEROSE GMBH**

Elly-Heuss-Knapp-Strasse 12  
 23843 Bad Oldesloe  
 Germany  
 Phone: +49 4531 509-0  
 Fax: +49 4531 509-120  
[info@herose.com](mailto:info@herose.com)

**International Subsidiaries**

**United Kingdom**

**HEROSE Ltd.**  
 3 Lindley Road  
**Finningley/Doncaster**  
 DN9 3DQ/U.K.  
 Mr. Keith Stewart  
 Phone: +44 1302 773 114  
 Fax: +44 1302 773 333  
[keith.stewart@herose.co.uk](mailto:keith.stewart@herose.co.uk)  
[www.herose.co.uk](http://www.herose.co.uk)

**Spain**









**HEROSE Iberica S.L.**  
 Deu i Mata, 117-121. 1-5.  
**08029 Barcelona**, Spain  
 Mr. Javier Gorriz  
 Phone: +34 662 625-614  
 Fax: +34 937 894-759  
[ofertas@herose.es](mailto:ofertas@herose.es)  
[www.herose.es](http://www.herose.es)

**P.R. China**

**HEROSE Trading Co., Ltd.**  
 Wanda Road 41-16#, Building 33  
 Jingang Industrial Park  
 Dalian Economy & Technology  
 Development Zone  
**Dalian 116600**, China  
 Mr. Guoyong Zhou  
 Phone: +86 411 6616 4388  
 Fax: +86 411 6616 4399  
[info@herose.cn](mailto:info@herose.cn)  
[www.herose.cn](http://www.herose.cn)

**India**

**HEROSE India**  
 IGEP Foundation, 630 - 636  
 6th Floor, Apparel House  
 Sector-44, Gurgaon  
**Haryana-122003** India  
 Mr. Sankalp Tiwari  
 Phone: +91 124 404 8273-77  
 Mobile: +91 98 1839 0222  
[tiwari.herose@igep.org](mailto:tiwari.herose@igep.org)  
[www.herose.com](http://www.herose.com)

Company	4	
Content	7	
<b>Onshore Applications</b>	11	
Gate Valves	12	
Outlet Valves	17	
Plug Cocks and Three-way Plug Cocks	22	
Ball Valves	27	
<b>Offshore Applications</b>	31	
Gate Valves	32	
Outlet Valves	35	
<b>Low Temperature Applications</b>	37	
Gate Valves	38	
General Information	41	

## Company

Throughout the world, HEROSE provides its customers with safety for handling technical gases, vapours and liquids in cryogenic applications and pressure vessels. With more than 140 years experience in the development, manufacture and sale of valves with a high level of innovation and modern production with certified quality management, HEROSE is one of the world's leading manufacturers of valves for industry and cryogenic applications. HEROSE employs around 200 employees and supplies to over 80 countries worldwide.



## Products

HEROSE offers a complete product range of globe, check and control valves as well as safety valves for cryogenic liquefied industrial gases like oxygen, nitrogen, hydrogen at temperatures down to  $-270^{\circ}\text{C}$  (3K) and for liquefied natural gas (LNG).

Additional HEROSE offers a large range of nonferrous safety valves for general industrial applications and DIN EN standard valves for engineering and plant construction industries.

## High Quality

No compromise on material selection, production and functional testing guarantee a hundred percent consistently high quality „Made in Germany“.





Headquarter in Bad Oldesloe – on more than 10,000 m<sup>2</sup> production and office area nearly 400,000 valves are produced every year



Frequently HEROSE offers trainings with integrated test lab demonstrations



HEROSE supplies valves for a wide range of industrial gas storage vessels from 180 to 500,000 litres and for larger LNG-vessels built on site



HEROSE-industrial safety valves are also used in the air supply unit of the breaking system for the high speed train Velaro RUS



HEROSE-valves for oil cooled transformers are proved to be used under the extreme climatic conditions for power generation at offshore sites



Material analysis and identification during the incoming goods check



100 % tightness test of the valves at design pressure



Continuous quality checks within the scope of the operator self check

# Product Catalogues at a glance

## CRYOGENIC

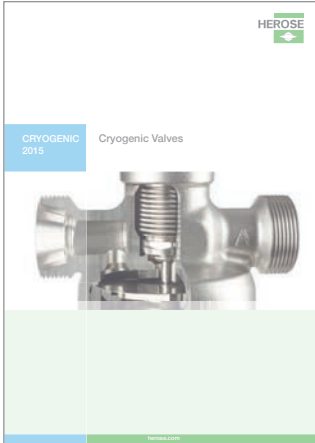

Valves and Safety Valves for

- Storage and Transportation of Cryogenic Gases
- Firesafe and Offshore Applications

## INDUSTRY

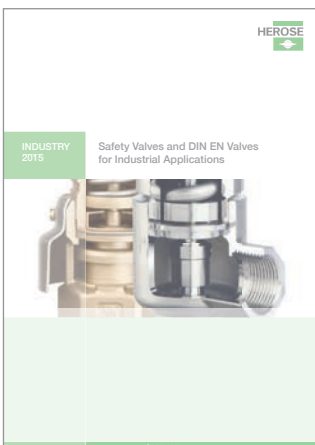

Valves for Industrial Applications

- Safety Valves and Overflow Valves
- DIN EN Valves

## ENERGY



Valves for oil-immersed Transformers for

- Onshore Applications
- Offshore Applications
- Low Temperature Applications



### Bronze Gate Valves for oil immersed Transformers

Type	Nominal size	Connections	Working pressure	Temperature	Page
09320	DN100 - DN250	Flanged	max. PN16, for oil max. 6,0 bar	-25°C - +120°C 248K - 393K	12
09420	DN25 - DN100	Flanged	max. PN16 for oil max. 6,0 bar	-25°C - +120°C 248K - 393K	13
09420	DN25 - DN100	Flanged	max. PN16 for oil max. 6,0 bar	-25°C - +120°C 248K - 393K	14
09420	DN25 - DN80	Flanged	max. PN16 for oil max. 6,0 bar	-25°C - +120°C 248K - 393K	15
09420	DN20 - DN80	Flanged - Guillemin	max. PN16 for oil max. 6,0 bar	-25°C - +120°C 248K - 393K	16

### Outlet Valves for oil immersed Transformers

Type	Nominal size	Connections	Working pressure	Temperature	Page
03196	DN15 - DN32	Flanged	max. PN6, for oil max. 6,0 bar	-20°C - +120°C 253K - 393K	17
03197	DN15 - DN32	Flanged	max. PN6, for oil max. 6,0 bar	-40°C - +180°C 233K - 453K	18
03198	DN15 - DN32	Flanged	max. PN6, for oil max. 6,0 bar	-40°C - +180°C 233K - 453K	19
03199	DN15 - DN32	Flanged	max. PN6, for oil max. 6,0 bar	-40°C - +115°C 233K - 388K	20
30199	DN15 - DN32				21

### Bronze Plug cocks and Three-way Plug cocks for oil immersed Transformers

Type	Nominal size	Connections	Working pressure	Temperature	Page
12170	DN25 - DN80	Flanged	max. PN16	-25°C - +115°C 248K - 388K	22
14170	DN25 - DN80	Flanged	max. PN16	-25°C - +115°C 248K - 388K	23
14175	DN80	Flanged	max. PN16	-25°C - +115°C 248K - 388K	24
30060, 30170	DN25 - DN80				25

### Bronze Plug Key

Type	Nominal size				Page
55322	DN25 - DN80				26

### Ball Valves for oil immersed Transformers

Type	Nominal size	Connections	Working pressure	Temperature	Page
15210	DN15 - DN150	Flanged	max. PN40	-50°C - +230°C 223K - 503K	27
15215	DN15 - DN150	Flanged	max. PN40	-50°C - +230°C 223K - 503K	28
15230	DN15 - DN150	Flanged	max. PN16	-40°C - +220°C 233K - 493K	29
15235	DN15 - DN150	Flanged	max. PN16	-40°C - +220°C 233K - 493K	30

### Bronze Gate Valves for oil immersed Transformers

Type	Nominal size	Connections	Working pressure	Temperature	Page
09320	DN100 - DN250	Flanged	max. PN16, for oil max. 6,0 bar	-25°C - +120°C 248K - 393K	32
09420	DN25 - DN100	Flanged	max. PN16, for oil max. 6,0 bar	-50°C - +120°C 223K - 393K	33
09420	DN25 - DN100	Flanged	max. PN16, for oil max. 6,0 bar	-50°C - +120°C 223K - 393K	34

### Bronze Outlet Valves for oil immersed Transformers

Type	Nominal size	Connections	Working pressure	Temperature	Page
03199	DN15 - DN32	Flanged	max. PN6, for oil max. 6,0 bar	-50°C - +115°C 223K - 388K	35



# Low Temperature Applications Content



## Bronze Gate Valves for oil immersed Transformers

Type	Nominal size	Connections	Working pressure	Temperature	Page
09320	DN100 - DN250	Flanged	max. PN16, for oil max. 6,0 bar	-50°C - +120°C 223K - 393K	38
09420	DN25 - DN100	Flanged	max. PN16, for oil max. 6,0 bar	-50°C - +120°C 223K - 393K	39
09420	DN25 - DN100	Flanged	max. PN16, for oil max. 6,0 bar	-50°C - +120°C 223K - 393K	40



## Valves for Onshore Applications



An oil-cooled power transformer supplies a chemical plant in central Germany. Provided with HEROSE valves for onshore applications.

# Gate Valves

## Type 09320



### Flanged Gate Valves, PN10 - 16, DIN EN 12288

Bronze body and topwork  
with maintenance-free gland packing (O-Ring) and non rising stem  
flanged connection acc. to DIN EN 1092-3 PN10 or PN16

#### Part No. 09320.X.110000

· Valve with opening indicator and locking device without lock

#### Part No. 09320.X.120000

· Valve with opening indicator and locking device with lock



### Applications:

Suitable for transformer oil.

Working temperatures: -25°C / -13°F (248K) up to +120°C / +248°F (393K) and maximum 6.0 bar

Materials	DIN EN	ASTM
1 Body	CC491K	B 62 UNS C83600
2 Wedge	CC491K	B 62 UNS C83600
3 Stem	CW614N	B 283 UNS C38500
4 Bonnet gasket	Klingsil C-4400	
5 Headpiece	CC491K	B 62 UNS C38600
6 Bolts	1.4571/A4 similar A 194 B8T	
7 O-Rings	FPM (Viton)	
8 Handwheel	Aluminium - diecasting	

**Essential:** When ordering or requesting an offer please indicate flow medium, working pressure and working temperature.

Standard marking acc. to Pressure Equipment Directive 97/23/EC (PED).

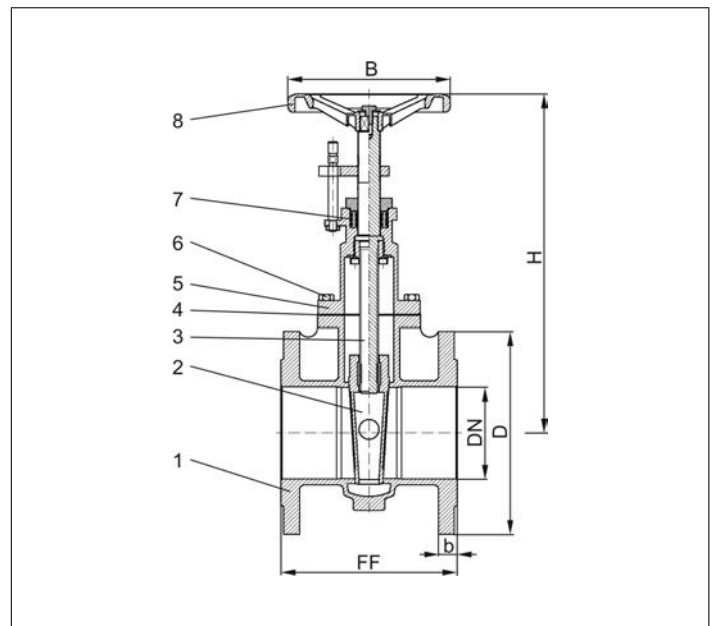

Type 09320	Technical data					
Nominal size	DN	100	125	150	200	250
Dimension code	X	1000	1250	1500	2000	2500
Max. working pressure	PN	16	16	16	10	10
Face-to-face dimension	FF	190	208	210	230	250
Height	H	367	429	469	593	690
Flange diameter	D	220	250	285	340	395
Flange connect DIN EN 1092-3	PN	16	16	16	10	10
Width of flange	b	20	22	22	24	24
Handwheel-Ø	B	175	200	225	300	300
Weight	approx. kg	23.5	32.0	42.5	71.0	106.0

Dimensions in mm.

# Gate Valves

## Type 09420



### Flanged Gate Valves, PN16, DIN EN 12288

Bronze body, screwed topwork in brass with maintenance-free gland packing (O-Ring) and non rising stem flanged connection acc. to DIN EN 1092-3 PN16

#### Part No. 09420.X.000000

· Standard valve

#### Part No. 09420.X.010000

· Valve with locking device without lock

#### Part No. 09420.X.020000

· Valve with locking device with lock

option:  
Locking device →



### Applications:

Suitable for transformer oil.

Working temperatures: -25°C / -13°F (248K) up to +120°C / +248°F (393K) and maximum 6.0 bar

Materials	DIN EN	ASTM
1 Body	CC491K	B 62 UNS C83600
2 Wedge	CC491K	B 62 UNS C83600
3 Stem	CW614N	B 283 UNS C38500
4 Bonnet gasket	Klingsil C-4400	
5 Headpiece	CW614N	B 283 UNS C38500
6 O-Rings	FPM (Viton)	
7 Handwheel	Aluminium - diecasting	

**Essential:** When ordering or requesting an offer please indicate flow medium, working pressure and working temperature.

Standard marking acc. to Pressure Equipment Directive 97/23/EC (PED).

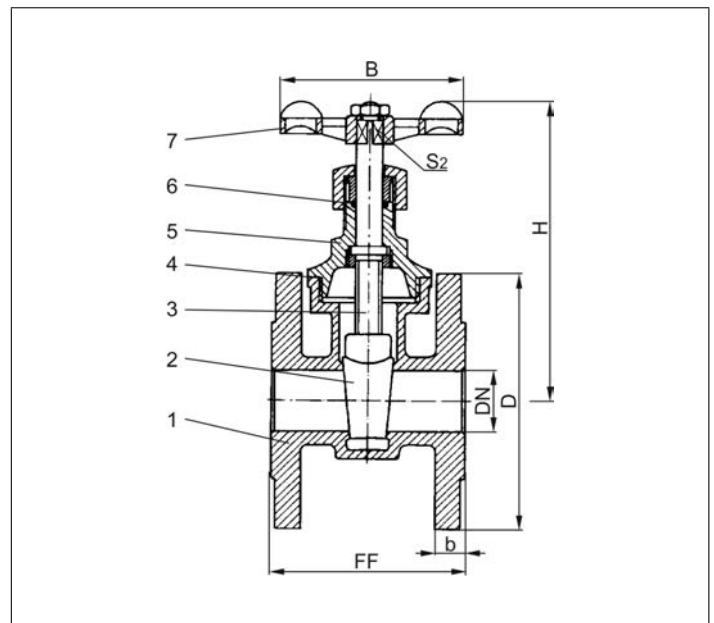

Type 09420	Technical data							
Nominal size	DN	25	32	40	50	65	80	100
Dimension code	.X.	0250	0320	0400	0500	0650	0800	1000
Face-to-face dimension	FF	80	90	100	110	130	150	165
Height	H	120	135	155	180	225	250	295
Flange diameter	D	115	140	150	165	185	200	220
Width of flange	b	12	14	14	16	16	18	20
Handwheel-Ø	B	70	80	80	110	130	150	150
Wrench size across flats	S <sub>2</sub>	8	9	9	11	12	14	14
Weight	approx. kg	2.5	3.9	4.9	7.0	9.5	12.1	19.0

Dimensions in mm.

# Gate Valves

## Type 09420



### Flanged Gate Valves, PN16, DIN EN 12288

Bronze body, screwed topwork in brass with maintenance-free gland packing (O-Ring) and non rising stem flanged connection acc. to DIN EN 1092-3 PN16

#### Part No. 09420.X.100000

· Valve with opening indicator

#### Part No. 09420.X.110000

· Valve with opening indicator and locking device without lock

#### Part No. 09420.X.120000

· Valve with opening indicator and locking device with lock

option:  
Locking device →



### Applications:

Suitable for transformer oil.

Working temperatures: -25°C / -13°F (248K) up to +120°C / +248°F (393K) and maximum 6.0 bar

Materials	DIN EN	ASTM
1 Body	CC491K	B 62 UNS C83600
2 Wedge	CC491K	B 62 UNS C83600
3 Stem	CW614N	B 283 UNS C38500
4 Bonnet gasket	Klingsil C-4400	
5 Headpiece	CW614N	B 283 UNS C38500
6 O-Rings	FPM (Viton)	
7 Handwheel	Aluminium - diecasting	

**Essential:** When ordering or requesting an offer please indicate flow medium, working pressure and working temperature.

Standard marking acc. to Pressure Equipment Directive 97/23/EC (PED).

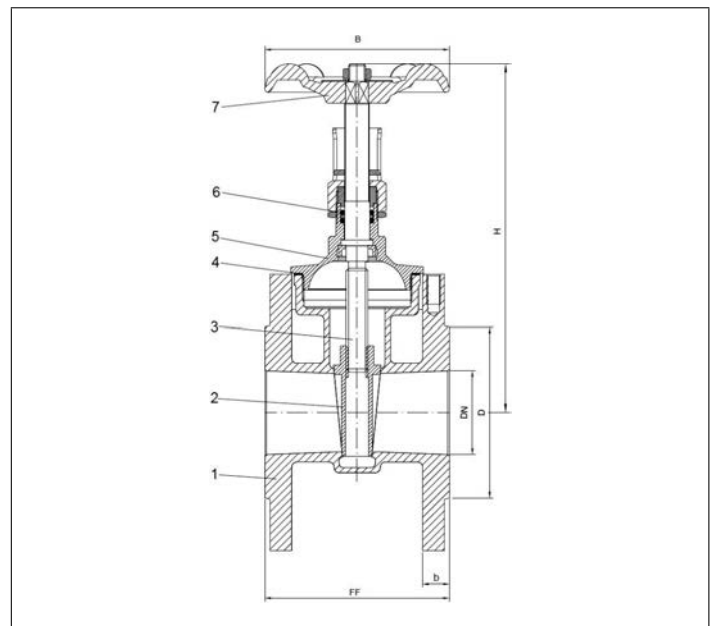

Type 09420	Technical data							
Nominal size	DN	25	32	40	50	65	80	100
Dimension code	.X.	0250	0320	0400	0500	0650	0800	1000
Face-to-face dimension	FF	80	90	100	110	130	150	165
Height	H	140	150	170	210	255	280	320
Flange diameter	D	115	140	150	165	185	200	220
Width of flange	b	12	14	14	16	16	18	20
Handwheel-Ø	B	70	80	80	110	130	150	150
Wrench size across flats	S <sub>2</sub>	8	9	9	11	12	14	14
Weight	approx. kg	2.6	4.0	4.9	6.8	8.0	12.2	19.0

Dimensions in mm.

# Gate Valves

## Type 09420



### Flanged Gate Valves, PN16, DIN EN 12288

Bronze body, screwed topwork in brass  
with maintenance-free gland packing (O-Ring) and non rising stem  
flanged connection acc. to DIN EN 1092-3, PN16

#### Part No. 09420.X.10D023

· Valve with opening indicator, flat flange with groove on both flanges

#### Part No. 09420.X.11D023

· Valve with opening indicator, flat flange with groove on both flanges and locking device without lock

#### Part No. 09420.X.12D023

· Valve with opening indicator, flat flange with groove on both flanges and locking device with lock

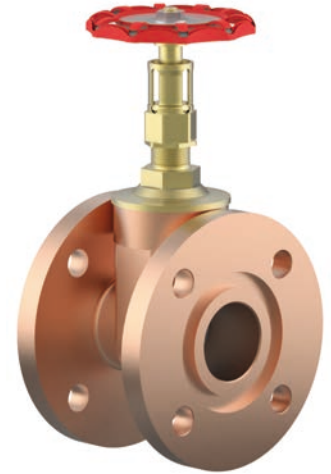

### Applications:

Suitable for transformer oil

Working temperatures: -25°C / -13°F (248K) up to +120°C / +248°F (393K) and maximum 6.0 bar.

Materials	DIN EN	ASTM
1 Body	CC491K	B 62 UNS C83600
2 Wedge	CC491K	B 62 UNS C83600
3 Stem	CW614N	B 455 UNS C38500
4 Bonnet gasket	Klingsil C-4400	
5 Headpiece	CW614N	B 455 UNS C38500
6 O-Rings	FPM (Viton)	
7 Handwheel	Aluminium - diecasting	

**Essential:** When ordering or requesting an offer please indicate flow medium, working pressure and working temperature.

Standard marking acc. to Pressure Equipment Directive 97/23/EC (PED).

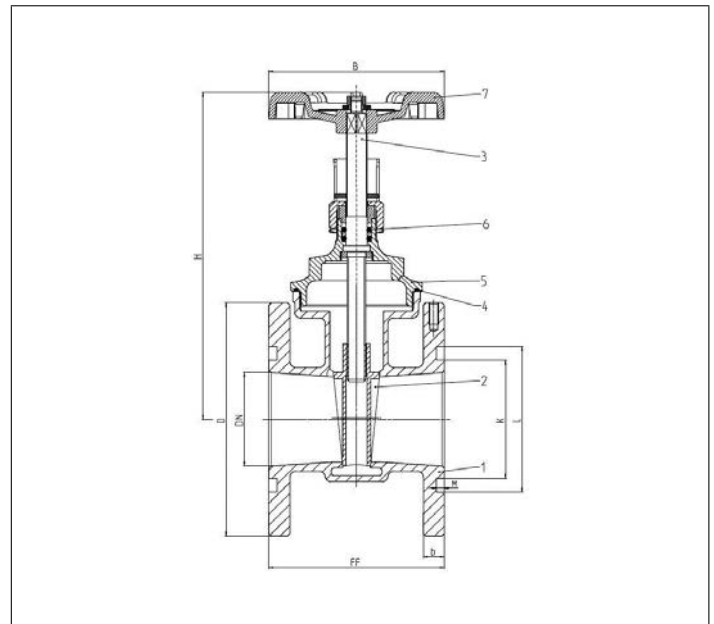

Type 09420	Technical data				
Nominal size	DN	25	40	50	80
Dimension code	.X.	0250	0400	0500	0800
Face-to-face dimension	FF	80	100	110	150
Height	H	138	169	208	281
Flange diameter	D	115	150	165	200
Inner diameter of the groove	K	44	61	69	101
Outer diameter of the groove	L	65	82	90	125
Groove depth	M	6	6	6	7
Width of flange	b	12	14	16	18
Handwheel-Ø	B	70	80	110	150
Wrench size across flats	S <sub>2</sub>	8	9	11	14
Weight	approx. kg	2.8	5.3	7.3	13.4

Dimensions in mm.

# Gate Valves

## Type 09420



### Flanged Gate Valves, PN16, DIN EN 12288 with "Guillemin"-outlet

Bronze body, screwed topwork in brass  
with maintenance-free gland packing (O-Ring) and non rising stem  
flanged connection acc. to DIN EN 1092-3 Pn16,  
sampling point with plug and chain

#### Part No. 09420.X.10C629

· Valve with opening indicator

#### Part No. 09420.X.11C629

· Valve with opening indicator and locking device without lock

#### Part No. 09420.X.12C629

· Valve with opening indicator and locking device with lock

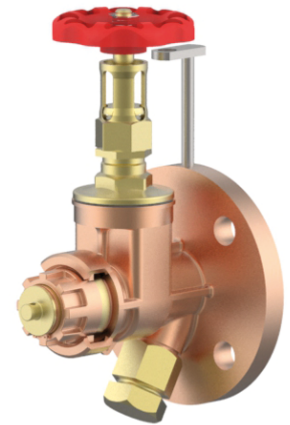

### Applications:

Suitable for transformer oil.

Working temperatures: -25°C / -13°F (248K) up to +120°C / 248°F (393K) and maximum 6.0 bar

Materials	DIN EN	ASTM
1 Body	CC491K	B 62 UNS C83600
2 Wedge	CC491K	B 62 UNS C83600
3 Stem	CW614N	B 455 UNS C38500
4 Bonnet gasket	Klingersil C-4400	
5 Headpiece	CW614N	B 455 UNS C38500
6 O-Ring	FPM (Viton)	
7 Handwheel	Aluminium - diecasting	
8 Plug	CW614N	B 455 UNS C38500
9 Plug part A	CW614N	B 455 UNS C38500
10 Plug part B	CC491K	B 62 UNS C83600

**Essential:** When ordering or requesting an offer please indicate flow medium, working pressure and working temperature.

Standard marking acc. to Pressure Equipment Directive 97/23/EC (PED).

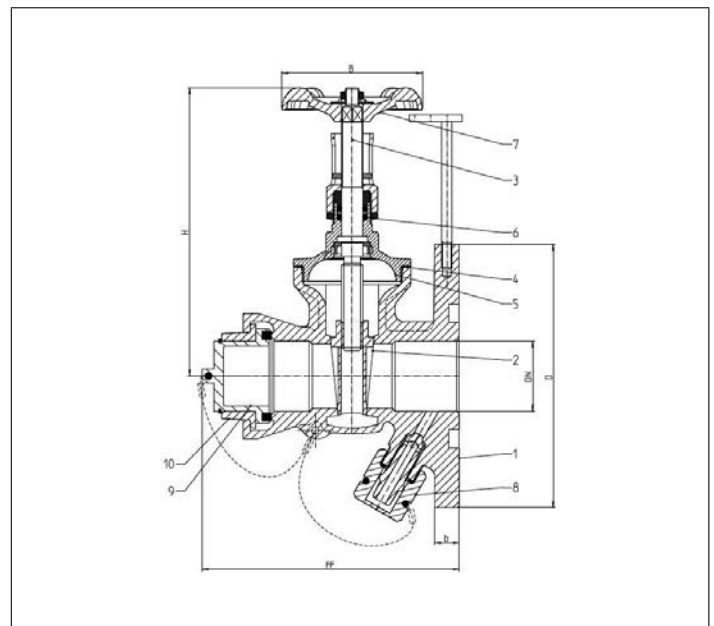

Type 09420	Technical data					
Nominal size	DN	20	25	40	50	80
Dimension code	.X.	0200	0250	0400	0500	0800
Face-to-face dimension	FF	110	114	146	168	190
Height	H	125	137	164	174	280
Flange diameter	D	105	115	150	165	200
Width of flange	b	12	12	14	16	18
Handwheel-Ø	B	70	70	80	110	150
Wrench size across flats	S <sub>2</sub>	7	8	9	11	14
Weight	approx. kg	1.8	2.1	4.4	5.4	11.7

Dimensions in mm.



# Outlet Valves

## Type 03196



### Outlet Valves, DIN 42568

Body and screwed topwork in brass, outlet with cap and chain, round/square flange, drilled acc. to DIN 2501 PN6

#### Part No. 03196.X.000510

· Standard design

#### Part No. 03196.X.010010

· Design with handwheel in aluminium (red) and locking device without lock

#### Part No. 03196.X.020010

· Design with handwheel in aluminium (red) and locking device with lock

Option:

Design with opening indicator



### Applications:

Suitable for transformer oil.

Working temperatures: -20°C / -4°F (253K) up to +120°C / +248°F (393K) and maximum 6.0 bar

Materials	DIN EN	ASTM
1 Body	CW614N	B 283 UNS C38500
2 Disc	CW614N	B 283 UNS C38500
3 Headpiece	CW614N	B 283 UNS C38500
4 Handwheel	Plastic	

**Essential:** When ordering or requesting an offer please indicate flow medium, working pressure and working temperature.

Standard marking acc. to Pressure Equipment Directive 97/23/EC (PED).

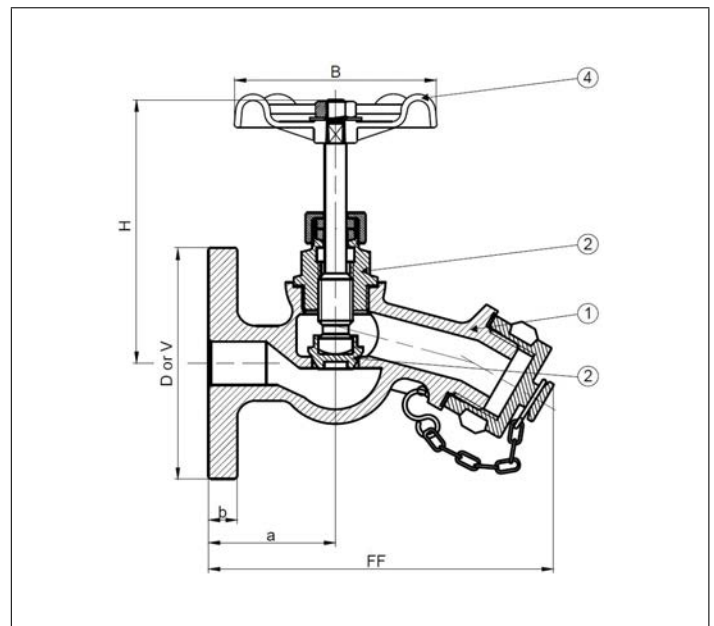

Type 03196	Technical data		
Nominal size	DN	15	32
Dimension code	.X.	0150	0320
Face-to-face dimension	FF	120	128
Height	H	92	133
Round-Flange-Ø	D	80	-
Square-Flange	V	-	90
Length	a	44	55
Width of flange	b	10	13
Handwheel- Ø	B	70	80
Weight	approx. kg	1.0	2.3

Dimensions in mm.

# Outlet Valves

## Type 03197



### Outlet Valves, DIN 42568

Body and screwed topwork in stainless steel (1.4308), outlet with cap and chain, round/square flange, drilled acc. to DIN 2501 PN6

#### Part No. 03197.X.000010

· Standard design

#### Part No. 03197.X.010010

· Design with handwheel in aluminium (black) and locking device without lock

#### Part No. 03197.X.020010

· Design with handwheel in aluminium (black) and locking device with lock

Option:

Design with opening indicator



### Applications:

Suitable for transformer oil.

Working temperatures: -40°C / -40°F (233K) up to +180°C / +356°F (453K) and maximum 6.0 bar

Materials	DIN EN	ASTM
1 Body	1.4308	A 351-CF8
2 Disc	1.4301	A 182-F304
3 Headpiece	1.4308	A 351-CF8
4 Handwheel	Aluminium	

**Essential:** When ordering or requesting an offer please indicate flow medium, working pressure and working temperature.

Standard marking acc. to Pressure Equipment Directive 97/23/EC (PED).

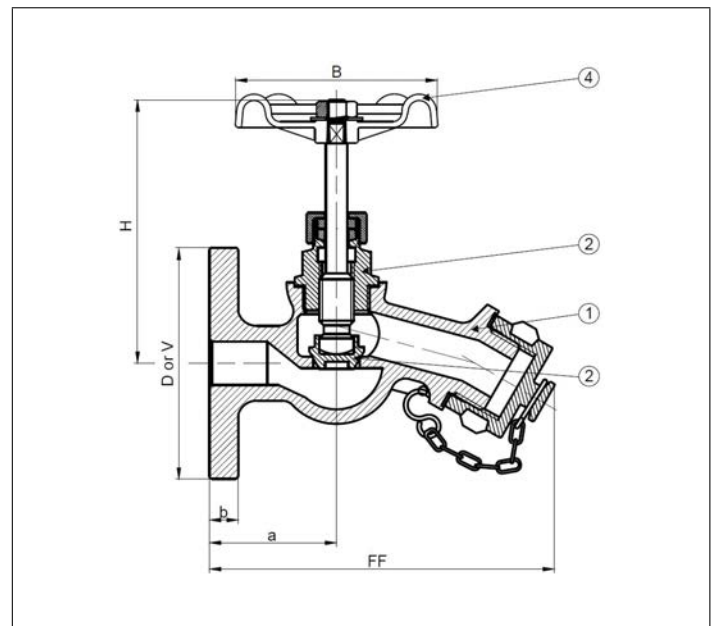

Type 03197	Technical data		
Nominal size	DN	15	32
Dimension code	.X.	0150	0320
Face-to-face dimension	FF	110	140
Height	H	95	133
Round-Flange-Ø	D	80	-
Square-Flange	V	-	90
Length	a	44	55
Width of flange	b	10	13
Handwheel- Ø	B	70	80
Weight	approx. kg	1.0	2.3

Dimensions in mm.

# Outlet Valves

## Type 03198



### Outlet Valves, DIN 42568

Body and screwed topwork in stainless steel (1.4408), outlet with cap and chain, round/square flange, drilled acc. to DIN 2501 PN6

#### Part No. 03198.X.000010

· Standard design

#### Part No. 03198.X.010010

· Design with handwheel in aluminium (black) and locking device without lock

#### Part No. 03198.X.020010

· Design with handwheel in aluminium (black) and locking device with lock

Option:

Design with opening indicator



### Applications:

Suitable for transformer oil.

Working temperatures: -40°C / -40°F (233K) up to +180°C / +356°F (453K) and maximum 6.0 bar

Materials	DIN EN	ASTM
1 Body	1.4408	A 351-CF8M
2 Disc	1.4301	A 182-F304
3 Headpiece	1.4408	A 351-CF8M
4 Handwheel	Aluminium	

**Essential:** When ordering or requesting an offer please indicate flow medium, working pressure and working temperature.

Standard marking acc. to Pressure Equipment Directive 97/23/EC (PED).

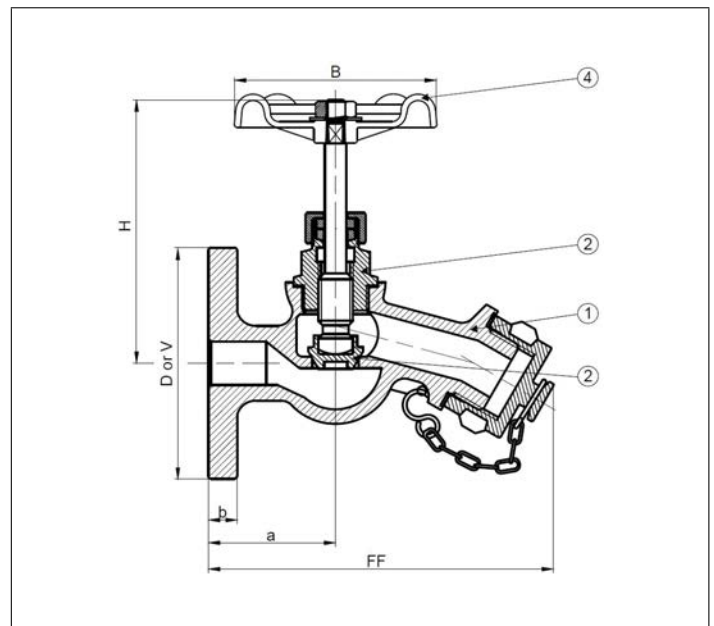

Type 03198	Technical data		
Nominal size	DN	15	32
Dimension code	.X.	0150	0320
Face-to-face dimension	FF	110	140
Height	H	95	133
Round-Flange-Ø	D	80	-
Square-Flange	V	-	90
Length	a	44	55
Width of flange	b	10	13
Handwheel- Ø	B	70	80
Weight	approx. kg	1.0	2.3

Dimensions in mm.

# Outlet Valves

## Type 03199



### Outlet Valves, DIN 42568

Bronze body and screwed topwork in brass  
Outlet with cap and chain, round/square flange,  
drilled acc. to DIN PN6

#### Part No. 03199.X.000500

· Standard design

#### Part No. 03199.X.010400

· Design with handwheel in cast iron (red) and locking device without lock

#### Part No. 03199.X.020400

· Design with handwheel in cast iron (red) and locking device with lock

Option:

Design with opening indicator



### Applications:

Suitable for transformer oil.

Working temperatures: -40°C / -40°F (233K) up to +115°C / +239°F (388K) and maximum 6.0 bar

Materials	DIN EN	ASTM
1 Body	CC491K	B 62 UNS C83600
2 Disc	CW614N	B 455 UNS C38500
3 Headpiece	CW614N	B 455 UNS C38500
4 Handwheel	PA6 (Polyamid)	

**Essential:** When ordering or requesting an offer please indicate flow medium, working pressure and working temperature.

Standard marking acc. to Pressure Equipment Directive 97/23/EC (PED).

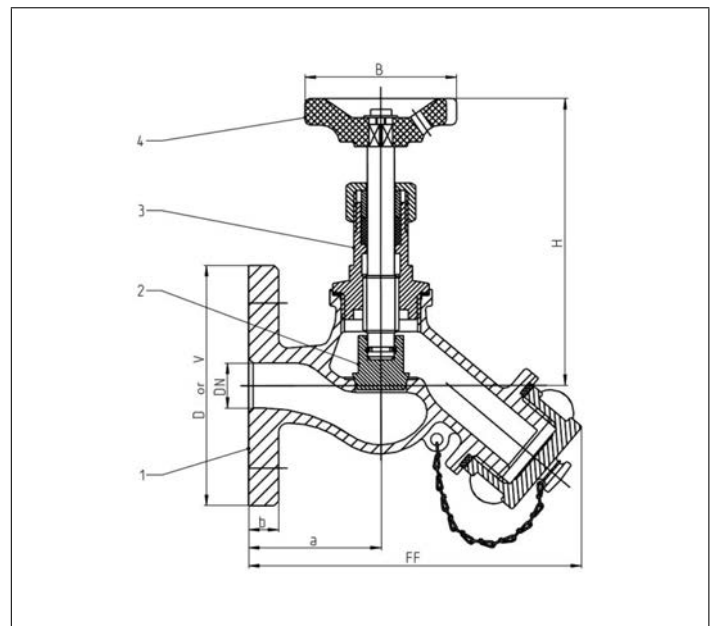

Type 03199	Technical data		
Nominal size	DN	15	32
Dimension code	.X.	0150	0320
Face-to-face dimension	FF	110	130
Height	H	97	120
Round-Flange-Ø	D	80	-
Square-Flange	V	-	90
Length	a	44	55
Width of flange	b	10	13
Handwheel- Ø	B	63	80
Weight	approx. kg	1.0	2.3

Dimensions in mm.

# Outlet Valves

## Type 30199



### Sealing kit for outlet valves type 03199

Sealing kit consisting of:

- Copper ring (headpiece/body)
- Polyamide ring (body/cap)

#### Part No. 30199.0150.0000

suitable for:

Type	Nominal size
03199	DN15

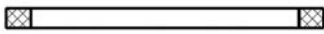

Sealing ring  
(Copper)

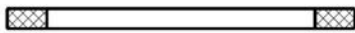

Sealing ring  
(Polyamide)



#### Part No. 30199.0320.0000

suitable for:

Type	Nominal size
03199	DN32

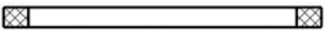

Sealing ring  
(Copper)

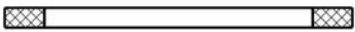

Sealing ring  
(Polyamide)



Type 30199	Technical Data		
Nominal size	DN	15	32
Dimension code	.X.	0150	0320
Dimensions copper ring	mm	35/27x2	42x51
Dimensions polyamide ring	mm	32/27x2	49/42x2
Weight	approx. kg	0.02	0.03

Dimensions in mm.

# Plug Cocks and Three-way Plug Cocks Type 12170



**Plug cock in Bronze, DIN 42544-A**  
with gland packing and square tap,  
with cap and safety catch

**Part No. 12170.X.0160**

· Standard version with round flanges drilled acc. to DIN PN 16

**Part No. 55322.0003.0105**

· Plug key in bronze for plug cock DN 25

**Part No. 55322.0004.0105**

· Plug key in bronze for plug cock DN 80



**Applications:**

Suitable for transformer oil.

Working temperatures: -25°C / -13°F (248K) up to +115°C / +239°F (388K) and maximum 5.0 bar.

Materials	DIN EN	ASTM
1 Body	CC491K	B 62 UNS C83600
2 Plug	CC491K	B 62 UNS C83600
3 Cap	CC491K	B 62 UNS C83600
4 Seal	PTFE	

**Essential:** When ordering or requesting an offer please indicate flow medium, working pressure and working temperature.

Standard marking acc. to Pressure Equipment Directive 97/23/EC (PED).

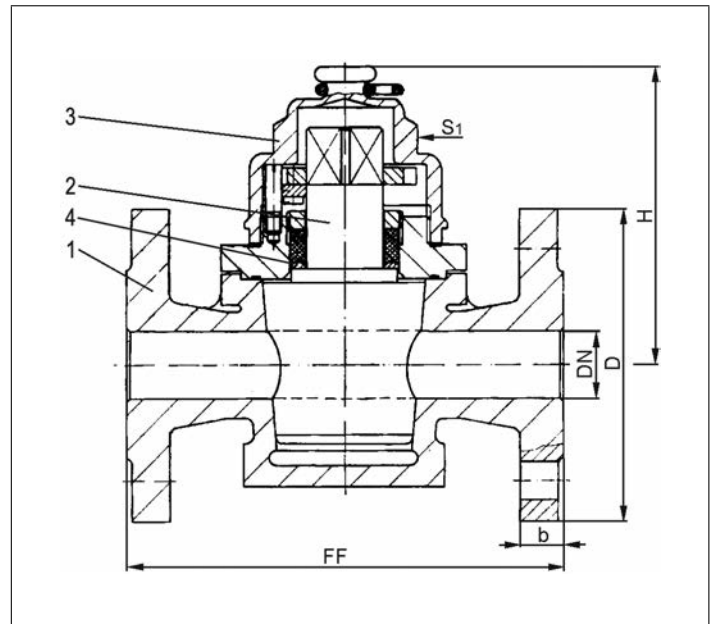

Type 12170	Technical data		
<b>Nominal size</b>	<b>DN</b>	<b>25</b>	<b>80</b>
Dimension code	.X.	0250	0800
Face-to-face dimension	FF	160	290
Height	H	115	155
Round-Flange-Ø	D	115	200
Width of flange	b	16	20
Wrench size across flats	S <sub>1</sub>	46	71
Weight	approx. kg	6.4	10.0

Dimensions in mm.

# Plug Cocks and Three-way Plug Cocks Type 14170



**Three-way plug cock in bronze, DIN 42544-B**  
with gland packing and square tap,  
with cap and safety catch,  
with T-port and round flanges drilled acc. to DIN PN 16

**Part No. 14170.X.LINK**

· Standard version, plug position stop left

**Part No. 14170.X.RECH**

· Plug position stop right

**Part No. 55322.0003.0105**

· Plug key in bronze for three-way plug cock DN 25

**Part No. 55322.0004.0105**

· Plug key in bronze for three-way plug cock DN 80



**Applications:**

Suitable for transformer oil.

Working temperatures: -25°C / -13°F (248K) up to +115°C / +239°F (388K) and maximum 5.0 bar.

Materials	DIN EN	ASTM
1 Body	CC491K	B 62 UNS C83600
2 Plug	CC491K	B 62 UNS C83600
3 Cap	CC491K	B 62 UNS C83600
4 Seal	PTFE	

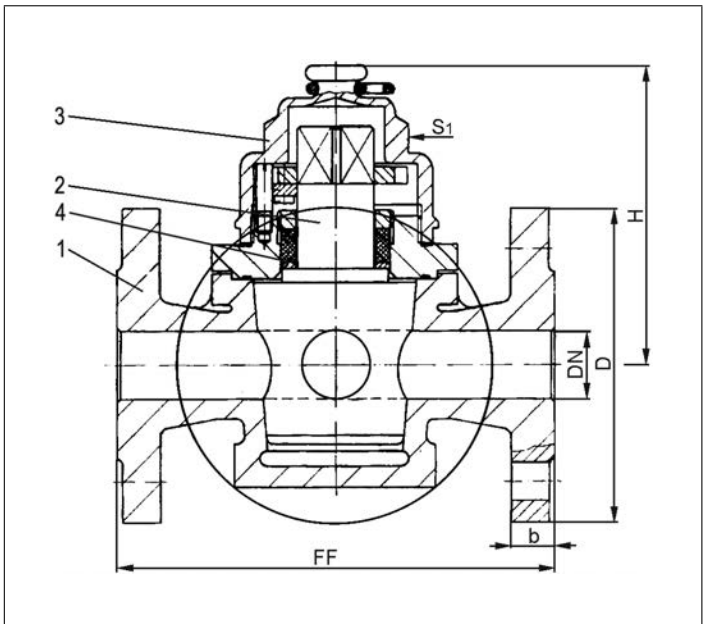

**Essential:** When ordering or requesting an offer please indicate flow medium, working pressure and working temperature.

Standard marking acc. to Pressure Equipment Directive 97/23/EC (PED).



Type 14170	Technical data		
<b>Nominal size</b>	<b>DN</b>	<b>25</b>	<b>80</b>
Dimension code	.X.	0250	0800
Face-to-face dimension	FF	160	290
Height	H	115	155
Rund-Flansch-Ø	D	115	200
Width of flange	b	16	20
Wrench size across flats	S <sub>1</sub>	46	71
Weight	approx. kg	7.9	22.0

Dimensions in mm.

# Plug Cocks and Three-way Plug Cocks Type 14175



**Three-way plug cock in Bronze, DIN 42544-C**  
with gland packing and square tap,  
with cap and safety catch,  
with T-port and square flanges drilled acc. to  $\text{Ø}132 \times 4 \times \text{Ø}18$

**Part No. 14175.X.0160**

· Standard version, plug position stop left

**Part No. 55322.0004.0105**

· Plug key in bronze for three-way plug cock DN 80

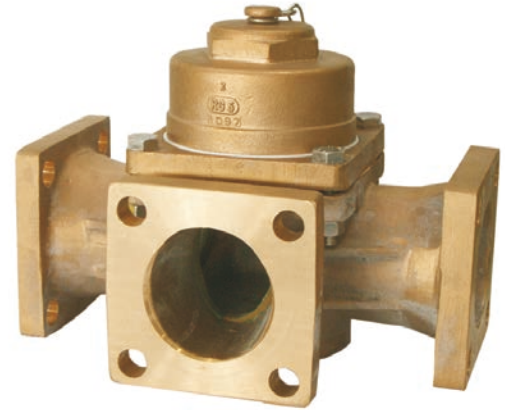

**Applications:**

Suitable for transformer oil.

Working temperatures:  $-25^{\circ}\text{C} / -13^{\circ}\text{F}$  (248K) up to  $+115^{\circ}\text{C} / +239^{\circ}\text{F}$  (388K) and maximum 5.0 bar.

Materials	DIN EN	ASTM
1 Body	CC491K	B 62 UNS C83600
2 Plug	CC491K	B 62 UNS C83600
3 Cap	CC491K	B 62 UNS C83600
4 Seal	PTFE	

**Essential:** When ordering or requesting an offer please indicate flow medium, working pressure and working temperature.

Standard marking acc. to Pressure Equipment Directive 97/23/EC (PED).

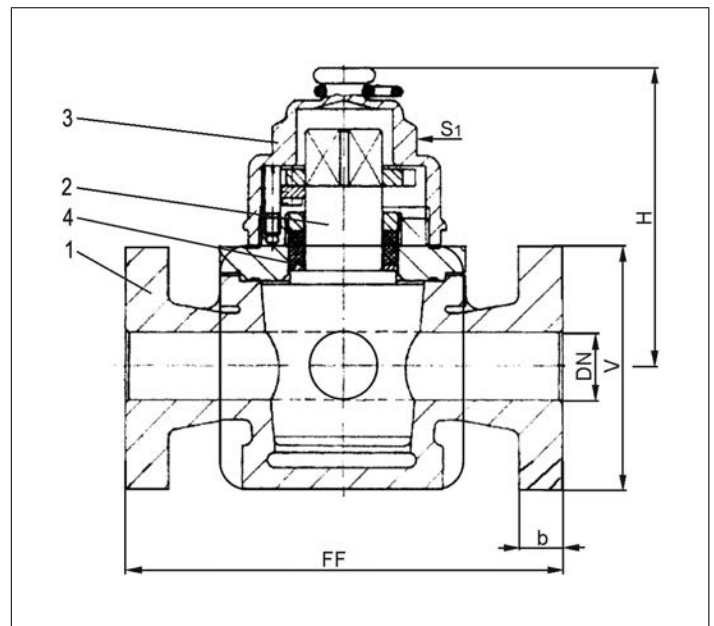

Type 14175	Technical data	
Nominal size	<b>DN</b>	<b>80</b>
Dimension code	.X.	0800
Face-to-face dimension	FF	290
Height	H	155
Square-Flange	V	125
Width of flange	b	18
Wrench size across flats	S <sub>1</sub>	71
Weight	approx. kg	22.0

Dimensions in mm.



# Plug Cocks and Three-way Plug Cocks

## Type 30060, 30170



### Spare parts for Plug Cocks and Three-way Plug Cocks Types 14060, 12170, 14170 and 14175

Gland packing Type 14060 consisting of:

- Gland packing

Sealing kit Types 12170, 14170 and 14175 consisting of:

- Gland seal
- Flat gasket
- O-ring

#### Part No. 30060.0500.0000

suitable for:

Type	Nominal size
14060	DN50

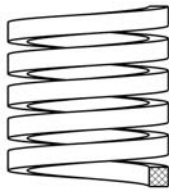

Gland packing (Ramie)



#### Part No. 30170.0250.0000

suitable for:

Types	Nominal size
12170, 14170, 14175	DN25



Gland seal (Perbunan)



Flat gasket (PTFE)



O-ring (PTFE)



#### Part No. 30170.0800.0000

suitable for:

Types	Nominal size
12170, 14170, 14175	DN80



Gland seal (Perbunan)



Flat gasket (PTFE)

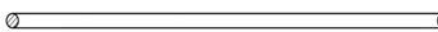

O-ring (PTFE)

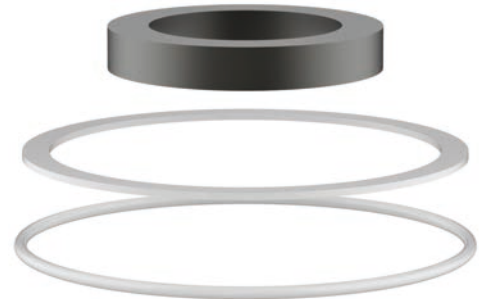

Type 30060	Technical data	
Nominal size	DN	50
Dimension code	.X.	0500
Cross section ramie	mm	6x6
Weight	approx. kg	0.02

Dimensions in mm.

Type 30170	Technical data		
Nominal size	DN	25	80
Dimension code	.X.	0250	0800
Dimensions gland seal	mm	39.5/28x10	77.0/54x12
Dimensions flat gasket	mm	68/63x2	125/110x2
Dimensions O-ring	mm	63x3	126.59x3.53
Weight	approx. kg	0.02	0.05

Dimensions in mm.

# Plug Cocks and Three-way Plug Cocks Type 55322



Plug key in Bronze, DIN 42544

**Part No. 55322.X.0105**

· Plug key in bronze for three-way plug cock DN 25

**Part No. 55322.X.0105**

· Plug key in bronze for three-way plug cock DN 80



Materials	DIN EN	ASTM
1 Plug key	CC491K	B 62 UNS C83600

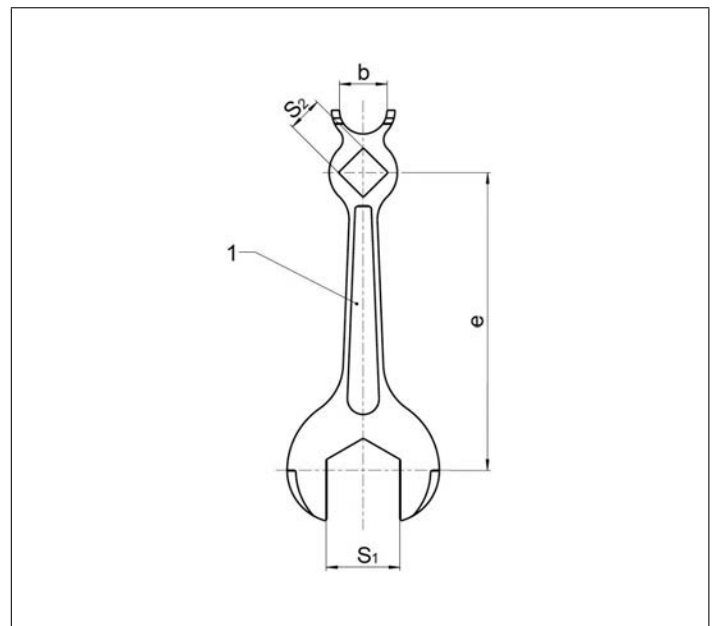

Type 55322	Technical data		
Nominal size	DN	25	80
Dimension code	.X.	0003	0004
Length	b	30	56
Length	e	188.5	481.5
Wrench size across flats	S <sub>1</sub>	46	71
Wrench size across flats	S <sub>2</sub>	22	41
Weight	approx. kg	0.9	3.8

Dimensions in mm.

# Ball Valves

## Type 15210



### Two-piece Flanged Ball Valves, cast steel, PN16 - 40, DIN EN

full bore, seat rings glass filled PTFE,  
gland packing with PTFE-rings  
with lever and locking device without lock  
face-to-face dimension acc. to DIN EN 558-1 row 27 (F4/5) - short pattern

**Part No. 15210.X.0600**



### Applications:

Suitable for non-toxic gases and fluids, oil.  
Working temperatures: -50°C / -58°F (223K) up to +230°C / +446°F (503K).

Materials	DIN EN	ASTM
1 Body	1.0619	A 216 Grade WCB
2 Ball	1.4308	A 351 CF8
3 Seat rings	PTFE-Fiberglass	
4 Stem	1.4401	A 216 Grade 316
5 Packing	PTFE	
6 Lever	1.4308	A 351 CF8

**Essential:** When ordering or requesting an offer please indicate flow medium, working pressure and working temperature.

Standard marking acc. to Pressure Equipment Directive 97/23/EC (PED).

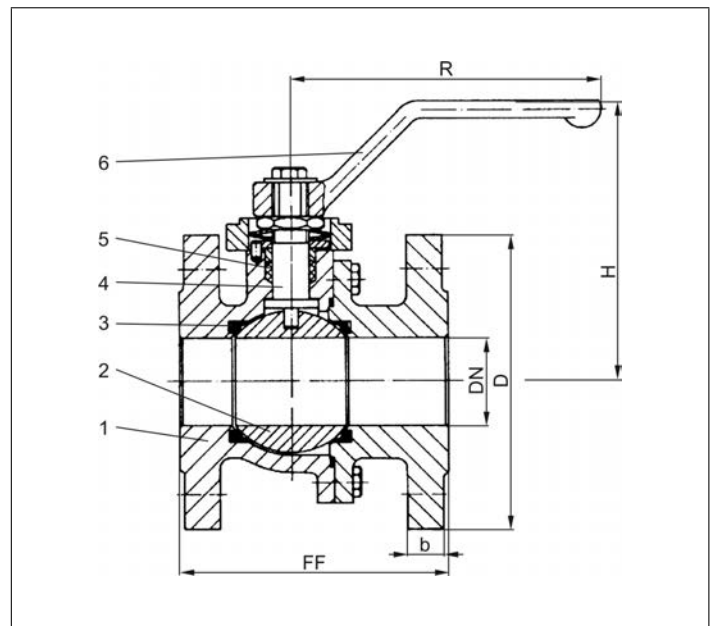

Type 15210	Technical data										
Nominal size	DN	15	20	25	32	40	50	65	80	100	150
Dimension code	X	0150	0200	0250	0320	0400	0500	0650	0800	1000	1500
Max. working pressure	PN	40	40	40	40	40	40	16	40	16	16
Face-to-face dimension	FF	115	120	125	130	140	150	170	180	190	350
Height	H	121	121	121	126	144	153	176	185	202	273
Flange diameter	D	95	105	115	140	150	165	185	200	220	285
Width of flange	b	16	18	18	18	18	20	18	24	20	22
Length	R	155	155	155	155	230	230	230	300	300	800
Weight	approx. kg	3.2	3.7	3.9	5.5	7.3	10.4	16.3	21.4	25.9	95

Dimensions in mm.

# Ball Valves

## Type 15215



### Two-piece Flanged Ball Valves, stainless steel, PN16 - 40, DIN EN

full bore, seat rings glass filled PTFE,  
gland packing with PTFE-rings  
with lever and locking device without lock  
face-to-face dimension acc. to DIN EN 558-1 row 27 (F4/5) - short pattern

**Part No. 15215.X.0600**



### Applications:

Suitable for non-toxic gases and fluids, oil, acid, solution and solvent.  
Working temperatures: -50°C / -58°F (223K) up to +230°C / +446°F (503K).

Materials	DIN EN	ASTM
1 Body	1.4408	A 351 CF8M
2 Ball	1.4408	A 351 CF8M
3 Seat rings	PTFE-Fiberglass	
4 Stem	1.4401	A 216 Grade 316
5 Packing	PTFE	
6 Lever	1.4308	A 351 CF8

**Essential:** When ordering or requesting an offer please indicate flow medium, working pressure and working temperature.

Standard marking acc. to Pressure Equipment Directive 97/23/EC (PED).

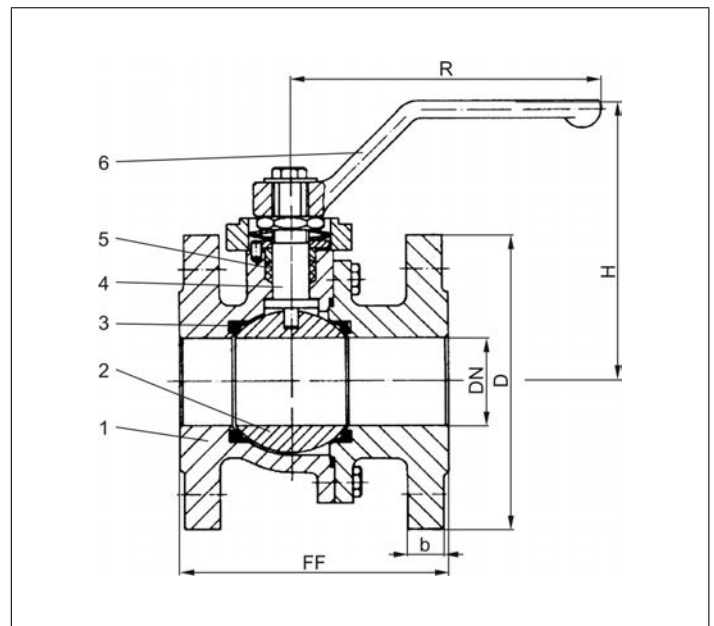

Type 15215	Technical data										
Nominal size	DN	15	20	25	32	40	50	65	80	100	150
Dimension code	X	0150	0200	0250	0320	0400	0500	0650	0800	1000	1500
Max. working pressure	PN	40	40	40	40	40	40	16	40	16	16
Face-to-face dimension	FF	115	120	125	130	140	150	170	180	190	350
Height	H	121	121	121	126	144	153	176	185	202	273
Flange diameter	D	95	105	115	140	150	165	185	200	220	285
Width of flange	b	16	18	18	18	18	20	18	24	20	22
Length	R	155	155	155	155	230	230	230	300	300	800
Weight	approx. kg	3.2	3.7	3.9	5.5	7.3	10.4	16.3	21.4	25.9	95

Dimensions in mm.

# Ball Valves

## Type 15230



### Two-piece Flanged Ball Valves, cast steel, PN16, DIN EN

full bore, seat rings PTFE, gland packing with PTFE-rings, with lever and locking device without lock, with ISO 5211 mounting pad, face-to-face dimension acc. to DIN EN 558-1 row 27 (F4) - short pattern, flanged connection acc. to DIN EN 1092-1 PN16

**Part No. 15230.X.11E000**

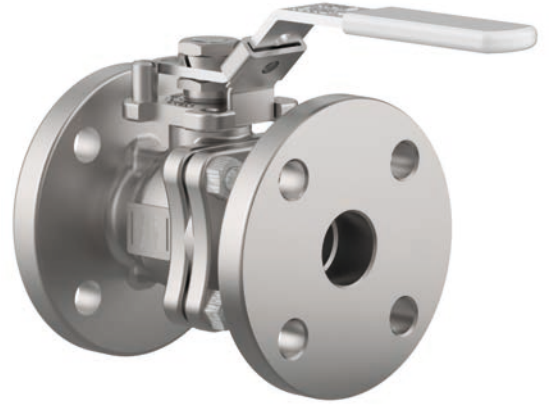

### Applications:

Suitable for transformer oil.

Working temperatures: -40°C / -40°F (233K) up to +220°C / +428°F (493K).

Materials	DIN EN	ASTM
1 Body	1.0619	A 216-WCB
2 Ball	1.4408	A 351-CF8M
3 Seat rings	PTFE	
4 Stem	1.4401	A 182-F316
5 Packing	PTFE	
6 Lever	1.4308	A 351-CF8

**Essential:** When ordering or requesting an offer please indicate flow medium, working pressure and working temperature.

Standard marking acc. to Pressure Equipment Directive 97/23/EC (PED).

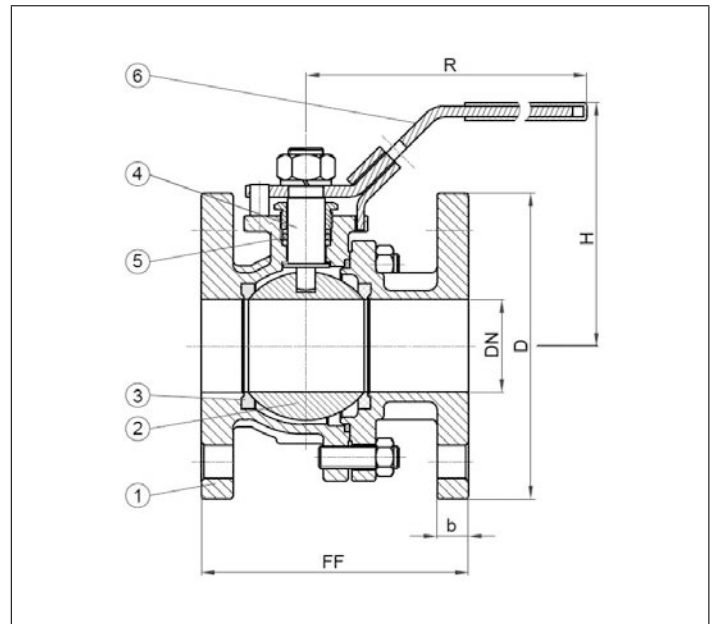

Type 15230	Technical data										
Nominal size	DN	15	20	25	32	40	50	65	80	100	150
Dimension code	X	0150	0200	0250	0320	0400	0500	0650	0800	1000	1500
Max. working pressure	PN	16	16	16	16	16	16	16	16	16	16
Face-to-face dimension	FF	115	120	125	130	140	150	170	180	190	350
Height	H	76	78	92	95	126	132	166	176	190	247
Flange diameter	D	95	105	115	140	150	165	185	200	220	285
Width of flange	b	12	12	13.5	14	14	18	18	20	20	22
Length of lever	R	153	153	160	160	185	185	230	230	330	750
Weight	approx. kg	3.2	3.7	3.9	5.5	7.3	10.4	16.3	21.4	25.9	95.0

Dimensions in mm. Further nominal sizes on request.

# Ball Valves

## Type 15235



### Two-piece Flanged Ball Valves, stainless steel, PN16, DIN EN

full bore, seat rings PTFE, gland packing with PTFE-rings, with lever and locking device without lock, with ISO 5211 mounting pad, face-to-face dimension acc. to DIN EN 558-1 row 27 (F4) - short pattern, flanged connection acc. to DIN EN 1092-1 PN16

**Part No. 15235.X.11E000**

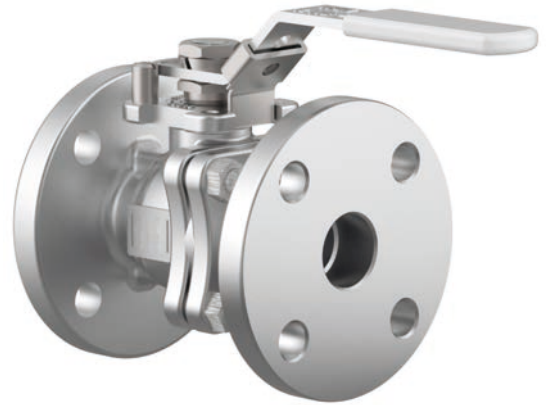

### Applications:

Suitable for transformer oil.

Working temperatures: -40°C / -40°F (233K) up to +220°C / +428°F (493K).

Materials	DIN EN	ASTM
1 Body	1.4408	A 351-CF8M
2 Ball	1.4408	A 351-CF8M
3 Seat rings	PTFE	
4 Stem	1.4401	A 182-F316
5 Packing	PTFE	
6 Lever	1.4308	A 351-CF8

**Essential:** When ordering or requesting an offer please indicate flow medium, working pressure and working temperature.

Standard marking acc. to Pressure Equipment Directive 97/23/EC (PED).

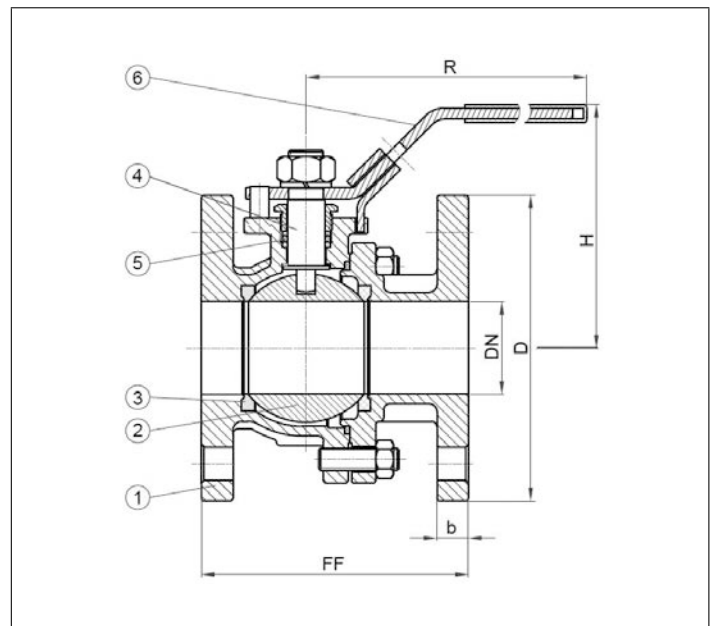

Type 15235	Technical data										
Nominal size	DN	15	20	25	32	40	50	65	80	100	150
Dimension code	X	0150	0200	0250	0320	0400	0500	0650	0800	1000	1500
Max. working pressure	PN	16	16	16	16	16	16	16	16	16	16
Face-to-face dimension	FF	115	120	125	130	140	150	170	180	190	350
Height	H	76	78	92	95	126	132	166	176	190	247
Flange diameter	D	95	105	115	140	150	165	185	200	220	285
Width of flange	b	12	12	13.5	14	14	18	18	20	20	22
Length of lever	R	153	153	160	160	185	185	230	230	330	750
Weight	approx. kg	3.2	3.7	3.9	5.5	7.3	10.4	16.3	21.4	25.9	95.0

Dimensions in mm. Further nominal sizes on request.

## Valves for Offshore Applications



The heart of an offshore wind farm is the transformer platform. It has the task to transform the electricity in order to transfer it to the mainland. The transformer are equipped with HEROSE valves for offshore applications.

# Gate Valves

## Type 09320



### Flanged Gate Valves, PN10 - 16, DIN EN 12288

Bronze body and topwork in seawater resistant bronze with maintenance-free gland packing (O-Ring) and non rising stem flanged connection acc. to DIN EN 1092-3 PN10 or PN16

#### Part No. 09320.X.110202

· Offshore - Valve with opening indicator and locking device without lock

#### Part No. 09320.X.120202

· Offshore - Valve with opening indicator and locking device with lock



### Applications:

Suitable for transformer oil.

Working temperatures: -25°C / -13°F (248K) up to +120°C / +248°F (393K) and maximum 6.0 bar

Materials	DIN EN	ASTM
1 Body	CC480K	B 30 UNS C90700
2 Wedge	CC480K	B 30 UNS C90700
3 Stem	CC480K	B 30 UNS C90700
4 Bonnet gasket	Klingsil C-4400	
5 Headpiece	CC480K	B 30 UNS C90700
6 Bolts	1.4571/A4 similar A 194 B8T	
7 O-Rings	FPM (Viton)	
8 Handwheel	CC491K	B 62 UNS C83600

**Essential:** When ordering or requesting an offer please indicate flow medium, working pressure and working temperature.

Standard marking acc. to Pressure Equipment Directive 97/23/EC (PED).

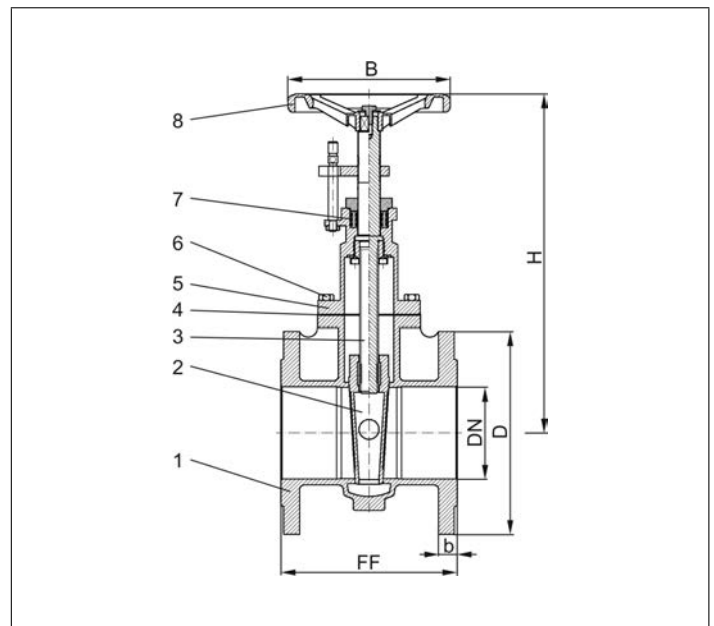

Type 09320	Technical data					
Nominal size	DN	100	125	150	200	250
Dimension code	X	1000	1250	1500	2000	2500
Max. working pressure	PN	16	16	16	10	10
Face-to-face dimension	FF	190	200	210	230	250
Height	H	352	410	449	585	680
Flange diameter	D	220	250	285	340	395
Flange connect. DIN EN 1092-3	PN	16	16	16	10	10
Width of flange	b	20	22	22	24	24
Handwheel-Ø	B	175	225	225	300	300
Weight	approx. kg	24.0	33.0	43.0	71.0	106.0

Dimensions in mm.



# Gate Valves

## Type 09420



### Flanged Gate Valves, PN16, DIN EN 12288

Body and screwed topwork in seawater resistant bronze with maintenance-free gland packing (O-Ring) and non rising stem  
flanged connection acc. to DIN EN 1092-3 PN16

#### Part No. 09420.X.000226

· Standard valve -50°C

#### Part No. 09420.X.010226

· Valve -50°C with locking device without lock

#### Part No. 09420.X.020226

· Valve -50°C with locking device with lock

option:  
Locking device →



### Applications:

Suitable for transformer oil.

Working temperatures: -50°C / -58°F (223K) up to +120°C / +248°F (393K) and maximum 6.0 bar

Materials	DIN EN	ASTM
1 Body	CC480K	B 30 UNS C90700
2 Wedge	CC480K	B 30 UNS C90700
3 Stem	CC483K	B 30 UNS C90800
4 Bonnet gasket	Klingsil C-4400	
5 Headpiece	CC480K	B 30 UNS C90700
6 O-Rings	Fluorosilicone	
7 Handwheel	CC491K	B 62 UNS C83600

**Essential:** When ordering or requesting an offer please indicate flow medium, working pressure and working temperature.

Standard marking acc. to Pressure Equipment Directive 97/23/EC (PED).

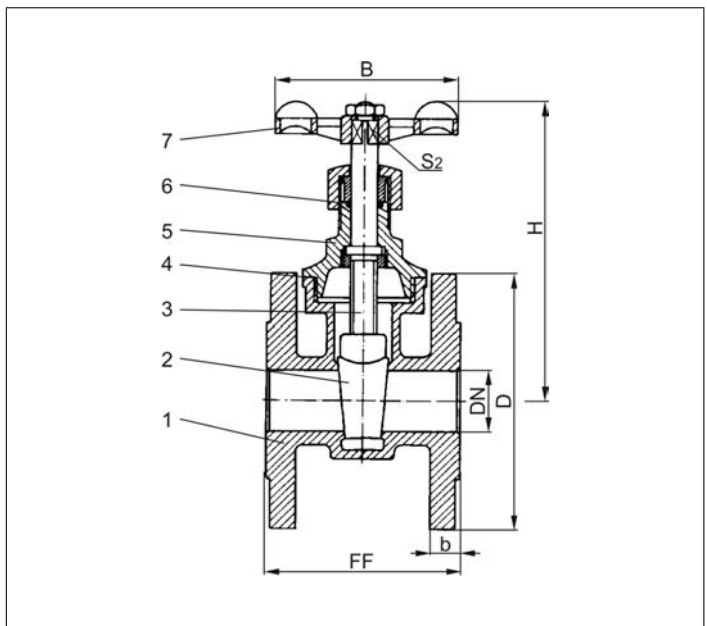

Type 09420	Technical data							
Nominal size	DN	25	32	40	50	65	80	100
Dimension code	.X.	0250	0320	0400	0500	0650	0800	1000
Face-to-face dimension	FF	80	90	100	110	130	150	165
Height	H	120	135	160	190	230	250	295
Flange diameter	D	115	140	150	165	185	200	220
Width of flange	b	12	14	14	16	16	18	20
Handwheel-Ø	B	80	100	100	125	140	150	150
Wrench size across flats	S <sub>2</sub>	8	9	9	11	12	14	14
Weight	approx. kg	2.5	3.9	4.9	7.0	9.5	12.1	19.0

Dimensions in mm.

# Gate Valves

## Type 09420



### Flanged Gate Valves, PN16, DIN EN 12288

Body and screwed topwork in seawater resistant bronze with maintenance-free gland packing (O-Ring) and non rising stem  
flanged connection acc. to DIN EN 1092-3 PN16

#### Part No. 09420.X.100226

· Valve -50°C with opening indicator

#### Part No. 09420.X.110226

· Valve -50°C with opening indicator and locking device without lock

#### Part No. 09420.X.120226

· Valve -50°C with opening indicator and locking device with lock

option:  
Locking device →



### Applications:

Suitable for transformer oil.

Working temperatures: -50°C / -58°F (223K) up to +120°C / +248°F (393K) and maximum 6.0 bar

Materials	DIN EN	ASTM
1 Body	CC480K	B 30 UNS C90700
2 Wedge	CC480K	B 30 UNS C90700
3 Stem	CC483K	B 30 UNS C90800
4 Bonnet gasket	Klingsil C-4400	
5 Headpiece	CC480K	B 30 UNS C90700
6 O-Rings	Fluorosilicone	
7 Handwheel	CC491K	B 62 UNS C83600

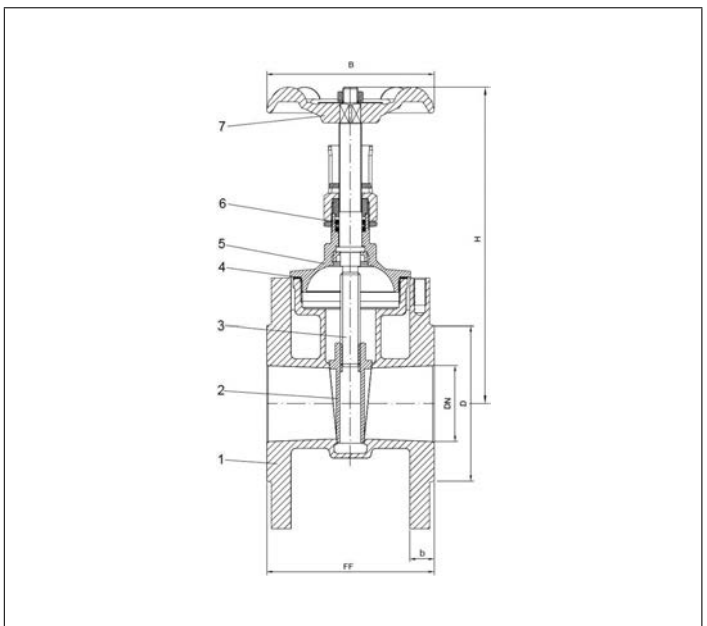

**Essential:** When ordering or requesting an offer please indicate flow medium, working pressure and working temperature.

Standard marking acc. to Pressure Equipment Directive 97/23/EC (PED).



Type 09420	Technical data							
Nominal size	DN	25	32	40	50	65	80	100
Dimension code	.X.	0250	0320	0400	0500	0650	0800	1000
Face-to-face dimension	FF	80	90	100	110	130	150	165
Height	H	145	160	175	220	260	280	320
Flange diameter	D	115	140	150	165	185	200	220
Width of flange	b	12	14	14	16	16	18	20
Handwheel-Ø	B	80	100	100	125	140	150	150
Wrench size across flats	S <sub>2</sub>	8	9	9	11	12	14	14
Weight	approx. kg	2.6	4.0	4.9	6.8	8.0	12.2	19.0

Dimensions in mm.

# Outlet Valves

## Type 03199



### Outlet Valves, DIN 42568

Bronze body and screwed topwork in seawater resistant bronze,  
Outlet with cap and steel cable, round/square flange,  
drilled acc. to DIN PN6

### Part No. 03199.X.110212

· Offshore-design with opening indicator and locking device without lock

### Part No. 03199.X.120212

· Offshore-design with opening indicator and locking device with lock



### Applications:

Suitable for transformer oil.

Working temperatures: -50°C / -58°F (223K) up to +115°C / +239°F (388K) and maximum 6.0 bar

Materials	DIN EN	ASTM
1 Body	CC480K	B 30 UNS C90700
2 Disc	CW452K	B 103 UNS C51900
3 Headpiece	CC483K	B 30 UNS C90800
4 Handwheel	CC491K	B 62 UNS C83600

**Essential:** When ordering or requesting an offer please indicate flow medium, working pressure and working temperature.

Standard marking acc. to Pressure Equipment Directive 97/23/EC (PED).

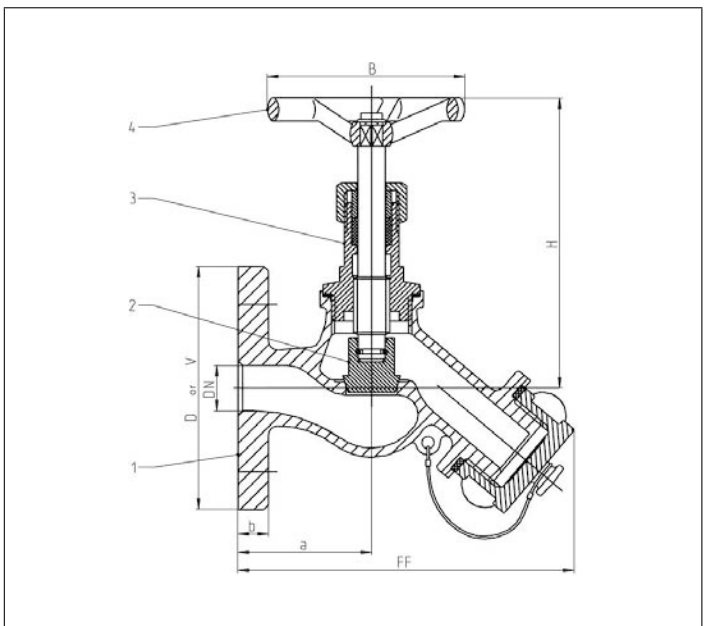

Type 03199	Technical data		
Nominal size	DN	15	32
Dimension code	.X.	0150	0320
Face-to-face dimension	FF	110	130
Height	H	97	120
Round-Flange-Ø	D	80	-
Square-Flange-Ø	V	-	90
Length	a	44	55
Width of flange	b	10	13
Handwheel-Ø	B	63	80
Weight	approx. kg	1.0	2.3

Dimensions in mm.



# Valves for Low Temperature Applications



An oil-immersed transformer on its frozen way to the final place of installation. Equipped with HEROSE valves for low temperature applications.

# Gate Valves

## Type 09320



### Flanged Gate Valves, PN10 - 16, DIN EN 12288

Bronze body and topwork  
with maintenance-free gland packing (O-Ring) and non rising stem  
flanged connection acc. to DIN EN 1092-3 PN10 or PN16

#### Part No. 09320.X.110200

· Valve -50°C with opening indicator and locking device without lock

#### Part No. 09320.X.120200

· Valve -50°C with opening indicator and locking device with lock



### Applications:

Suitable for transformer oil.

Working temperatures: -50°C / -58°F (223K) up to +120°C / +248°F (393K) and maximum 6.0 bar

Materials	DIN EN	ASTM
1 Body	CC491K	B 62 UNS C83600
2 Wedge	CC491K	B 62 UNS C83600
3 Stem	CW614N	B 283 UNS C38500
4 Bonnet gasket	Klingsil C-4400	
5 Headpiece	CC491K	B 62 UNS C83600
6 Bolts	1.4571/A4 similar A 194 B8T	
7 O-Rings	Fluor - Silicon	
8 Handwheel	CC491K	B 62 UNS C83600

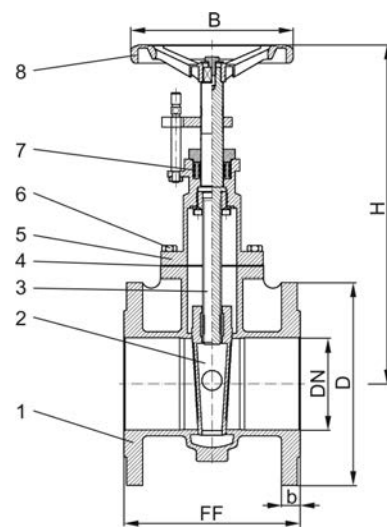

**Essential:** When ordering or requesting an offer please indicate flow medium, working pressure and working temperature.

Standard marking acc. to Pressure Equipment Directive 97/23/EC (PED).



Type 09320	Technical data					
Nominal size	DN	100	125	150	200	250
Dimension code	X	1000	1250	1500	2000	2500
Max. working pressure	PN	16	16	16	10	10
Face-to-face dimension	FF	190	208	210	230	250
Height	H	352	410	449	585	680
Flange diameter	D	220	250	285	340	395
Flange connect. DIN EN 1092-3	PN	16	16	16	10	10
Width of flange	b	20	22	22	24	24
Handwheel-Ø	B	175	225	225	300	300
Weight	approx. kg	23.5	32.0	43.0	71.0	106.0

Dimensions in mm.

# Gate Valves

## Type 09420



### Flanged Gate Valves, PN16, DIN EN 12288

Bronze body, screwed topwork in brass with maintenance-free gland packing (O-Ring) and non rising stem flanged connection acc. to DIN EN 1092-3 PN16

#### Part No. 09420.X.000200

· Standard valve -50°C

#### Part No. 09420.X.010200

· Valve -50°C with locking device without lock

#### Part No. 09420.X.020200

· Valve -50°C with locking device with lock

option:  
Locking device →



### Applications:

Suitable for transformer oil.

Working temperatures: -50°C / -58°F (223K) up to +120°C / +248°F (393K) and maximum 6.0 bar

Materials	DIN EN	ASTM
1 Body	CC491K	B 62 UNS C83600
2 Wedge	CC491K	B 62 UNS C83600
3 Stem	CW614N	B 283 UNS C38500
4 Bonnet gasket	Klingsil C-4400	
5 Headpiece	CW614N	B 283 UNS C38500
6 O-Rings	Fluor - Silicon	
7 Handwheel	CC491K	B 62 UNS C83600

**Essential:** When ordering or requesting an offer please indicate flow medium, working pressure and working temperature.

Standard marking acc. to Pressure Equipment Directive 97/23/EC (PED).

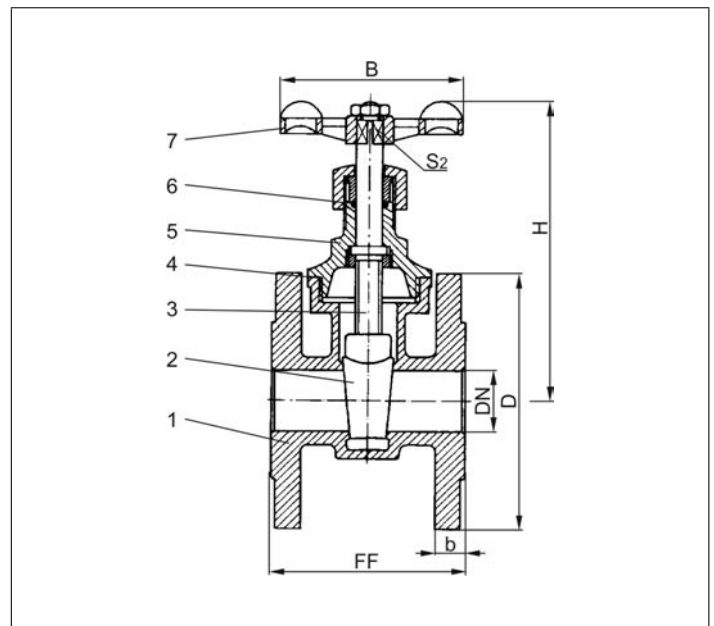

Type 09420	Technical data							
Nominal size	DN	25	32	40	50	65	80	100
Dimension code	.X.	0250	0320	0400	0500	0650	0800	1000
Face-to-face dimension	FF	80	90	100	110	130	150	165
Height	H	120	135	160	190	230	250	295
Flange diameter	D	115	140	150	165	185	200	220
Width of flange	b	12	14	14	16	16	18	20
Handwheel-Ø	B	80	100	100	125	140	150	150
Wrench size across flats	S <sub>2</sub>	8	9	9	11	12	14	14
Weight	approx. kg	2.5	3.9	4.9	7.0	9.5	12.1	19.0

Dimensions in mm.

# Gate Valves

## Type 09420



### Flanged Gate Valves, PN16, DIN EN 12288

Bronze body, screwed topwork in brass with maintenance-free gland packing (O-Ring) and non rising stem flanged connection acc. to DIN EN 1092-3 PN16

#### Part No. 09420.X.100200

· Valve -50°C with opening indicator

#### Part No. 09420.X.110200

· Valve -50°C with opening indicator and locking device without lock

#### Part No. 09420.X.120200

· Valve -50°C with opening indicator and locking device with lock

option:  
Locking device →



### Applications:

Suitable for transformer oil.

Working temperatures: -50°C / -58°F (223K) up to +120°C / +248°F (393K) and maximum 6.0 bar

Materials	DIN EN	ASTM
1 Body	CC491K	B 62 UNS C83600
2 Wedge	CC491K	B 62 UNS C83600
3 Stem	CW614N	B 283 UNS C38500
4 Bonnet gasket	Klingsil C-4400	
5 Headpiece	CW614N	B 283 UNS C38500
6 O-Rings	Fluor - Silicon	
7 Handwheel	CC491K	B 62 UNS C83600

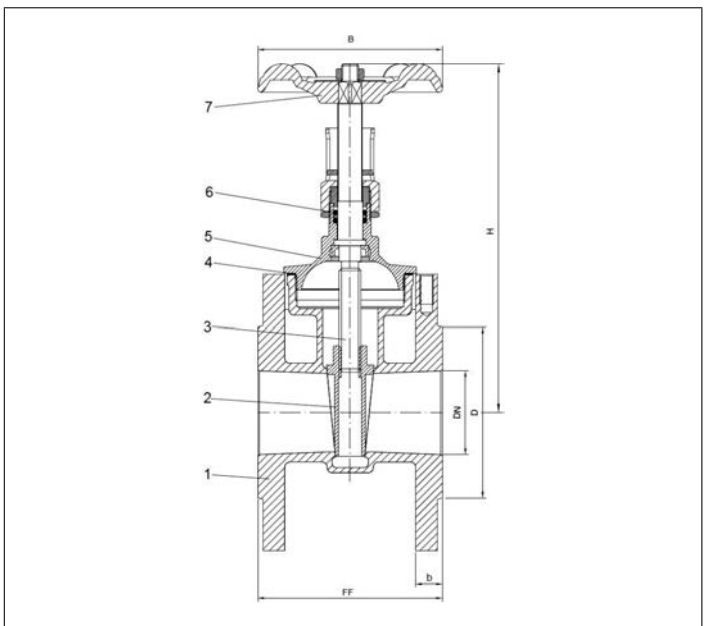

**Essential:** When ordering or requesting an offer please indicate flow medium, working pressure and working temperature.

Standard marking acc. to Pressure Equipment Directive 97/23/EC (PED).



Type 09420	Technical data							
Nominal size	DN	25	32	40	50	65	80	100
Dimension code	.X.	0250	0320	0400	0500	0650	0800	1000
Face-to-face dimension	FF	80	90	100	110	130	150	165
Height	H	145	160	175	220	260	280	320
Flange diameter	D	115	140	150	165	185	200	220
Width of flange	b	12	14	14	16	16	18	20
Handwheel-Ø	B	80	100	100	125	140	150	150
Wrench size across flats	S <sub>2</sub>	8	9	9	11	12	14	14
Weight	approx. kg	2.6	4.0	4.9	6.8	8.0	12.2	19.0

Dimensions in mm.



## Nonferrous materials

DIN EN new		DIN old		ASTM
CC490K	CuSn3Zn8Pb5-C	RG2	2.1098	-
CC491K	CuSn5Zn5Pb5-C	RG5	2.1096.01	B 62 UNS C83600
CC493K	CuSn7Zn4Pb7-C	RG7	2.1090	B 505 UNS C93200
CW450K	CuSn4	CUSN4	2.1016	B 103 UNS C51100
CW452K	CuSn6	CUSN6	2.1020	B 159 UNS C51900
CW453K	CuSn8	CUSN8	2.1030	B 103 UNS C52100
CW507L	CuZn36	CUZN36	2.0335	B 111 UNS C27000
CW508L	CuZn37	CUZN37	2.0321	B 111 UNS C27200
CW509L	CuZn40	CUZN40	2.0360	B 111 UNS C28000
CW610N	CuZn39Pb0,5	CUZN39PB	2.0372	B 111 UNS C36500
CW612N	CuZn39Pb2	MS58	2.0380.10	B 283 UNS C37770
CW614N	CuZn39Pb3	MS58	2.0401.08	B 283 UNS C38500
CW617N	CuZn40Pb2	MS58	2.0402.20	B 283 UNS C38000
CW710R	CuZn35Ni3Mn2AlPb	CUZN35NI	2.0540	-
CW713R	CuZn37Mn3Al2PbSi	CUZN40AL	2.0552	-
CW718R	CuZn39Mn1AlPbSi	CUZN40AL	2.0561	-
CW720R	CuZn40Mn1Pb1	CUZN40MN	2.0580	-
CW723R	CuZn40Mn2Fe1	CUZN40MN	2.0572	-

## Ferrous materials

DIN EN new		DIN old	ASTM
1.1200	Spring steel	Carbon steel	A 227
1.4021	C20Cr13	1.4021	A 276 Grade 420
1.4034	X45Cr13	1.4034	A 276 Grade 420
1.4057	X17CrNi16-2	1.4057	A 276 Grade 431
1.4104	X14CrMoS17	1.4104	A 276 Grade 430F
1.4112	X90CrMoV18	1.4112	A 276 Grade 440B
1.4122	X39CrMo17-1	1.4122	-
1.4300	X12CrNi18-8	1.4300	A 276 Grade 302
1.4301	X5CrNi18-10	1.4301	A 276 Grade 304
1.4305	X8CrNiS18-9	1.4305	A 276 Grade 303
1.4306	X2CrNi19-11	1.4306	A 312 TP 304L
1.4308	G-X6CrNi18-9	1.4308	A 351 CF8
1.4310	X10CrNi18-8	1.4310	A 313 Grade 301
1.4401	X5CrNiMo17-12-2	1.4401	A 276 Grade 316
1.4404	X2CrNiMo17-12-2	1.4404	A 276 Grade 316L
1.4408	GX5CrNiMo19-11-2	1.4408	A 351 CF 8M
1.4409	G-X2NiCrMo28-20-2	1.4409	A 351 CF 3M
1.4541	X6CrNiTi18-10	1.4541	A 276 Grade 321
1.4568	X7CrNiAl17-7	1.4568	A 313 Grade 631
1.4571	X6CrNiMoTi17-12-2	1.4571	A 313 Grade 316Ti
1.4552	G-X7CrNiNb18-9	1.4552	A 351 CF 8C
1.4923	X22CrMoV12-1	1.4923	A 193 Grade B6
1.4980	X5CrNiTi26-15	1.4980	A 286 Grade 660
1.5415	16Mo3	-	A 182 Grade F1
1.7225	42CrMo4	1.7225	A 194 Grade 7
1.7258	24CrMo5	1.7258	A 194 Grade B7
1.7335	13CrMo4-5	1.7335	A 182 Grade F12
1.7380	10CrMo9-10	1.7380	A 182 Grade F22
1.7709	21CrMoV5-7	1.7709	-

# Dimensions of DIN flanges



**DN** = Nominal diameter  
**D** = Diameter of flange  
**Lk** = Diameter of bolt circle  
**n** = Number of holes  
**d** = Diameter of holes

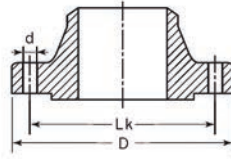

DN		PN 6				PN 10				PN 16				PN 25				PN 40			
		D	Lk	n	d	D	Lk	n	d	D	Lk	n	d	D	Lk	n	d	D	Lk	n	d
10	3/8"	75	50	4	11	90	60	4	14	90	60	4	14	90	60	4	14	90	60	4	14
15	1/2"	80	55	4	11	95	65	4	14	95	65	4	14	95	65	4	14	95	65	4	14
20	3/4"	90	65	4	11	105	75	4	14	105	75	4	14	105	75	4	14	105	75	4	14
25	1"	100	75	4	11	115	85	4	14	115	85	4	14	115	85	4	14	115	85	4	14
32	1-1/4"	120	90	4	14	140	100	4	18	140	100	4	18	140	100	4	18	140	100	4	18
40	1-1/2"	130	100	4	14	150	110	4	18	150	110	4	18	150	110	4	18	150	110	4	18
50	2"	140	110	4	14	165	125	4	18	165	125	4	18	165	125	4	18	165	125	4	18
65	2-1/2"	160	130	4	14	185	145	4	18	185	145	4	18	185	145	8	18	185	145	8	18
80	3"	190	150	4	18	200	160	8	18	200	160	8	18	200	160	8	18	200	160	8	18
100	4"	210	170	4	18	220	180	8	18	220	180	8	18	235	190	8	22	235	190	8	22
125	5"	240	200	8	18	250	210	8	18	250	210	8	18	270	220	8	26	270	220	8	26
150	6"	265	225	8	18	285	240	8	22	285	240	8	22	300	250	8	26	300	250	8	26
200	8"	320	280	8	18	340	295	8	22	340	295	8	22	360	310	12	26	375	320	12	30

DN		PN 63				PN 100				PN 160				PN 250				PN 320			
		D	Lk	n	d	D	Lk	n	d	D	Lk	n	d	D	Lk	n	d	D	Lk	n	d
10	3/8"	100	70	4	14	100	70	4	14	100	70	4	14	125	85	4	18	125	85	4	18
15	1/2"	105	75	4	14	105	75	4	14	105	75	4	14	130	90	4	18	130	90	4	18
20	3/4"	-	-	-	-	-	-	-	-	-	-	-	-	-	-	-	-	-	-	-	-
25	1"	140	100	4	18	140	100	4	18	140	100	4	18	150	105	4	22	160	115	4	22
32	1-1/4"	-	-	-	-	-	-	-	-	-	-	-	-	-	-	-	-	-	-	-	-
40	1-1/2"	170	125	4	22	170	125	4	22	170	125	4	22	185	125	4	26	195	145	4	26
50	2"	180	135	4	22	195	145	4	26	195	145	4	26	200	150	8	26	210	160	8	26
65	2-1/2"	205	160	4	22	220	170	8	26	220	170	8	26	230	180	8	26	255	200	8	30
80	3"	215	170	4	22	230	180	8	26	230	180	8	26	255	200	8	30	275	220	8	30
100	4"	250	200	4	22	265	210	8	30	265	210	8	30	300	235	8	30	300	265	8	36

# CERTIFICATE



Management system as per  
**DIN EN ISO 9001 : 2008**

In accordance with TÜV NORD CERT procedures, it is hereby certified that

**HEROSE GMBH**  
**ARMATUREN UND METALLE**  
Elly-Heuss-Knapp-Straße 12  
23843 Bad Oldesloe  
Germany



with the site **HEROSE Valves Co., Ltd., Building 18, JinGang Industry Park,  
Dalian Economy & Technology Development Park No. 49, Dalian 116600, China**

applies a management system in line with the above standard for the following scope

**Development, Manufacture and Sales of  
Industrial Valves and Pressure Safety Valves**

Certificate Registration No. 78 100 023710  
Audit Report No. 3513 7037

Valid until 2017-08-14  
Initial certification 2002

**Kaas**  
Certification Body  
at TÜV NORD CERT GmbH

Essen, 2014-08-15

This certification was conducted in accordance with the TÜV NORD CERT auditing and certification procedures and is subject to regular surveillance audits.

TÜV NORD CERT GmbH

Langemarckstrasse 20

45141 Essen







[www.tuev-nord-cert.com](http://www.tuev-nord-cert.com)



TGA-ZM-07-06-00

Nowadays, product approvals are essential for many customer applications. Below is an excerpt of our most important certifications. A detailed list can be found at [herose.com](http://herose.com).

## Type approvals

Approval company	Approval	Mark
TÜV	CE LNG (DIN EN 12567) Firesafe (DIN EN ISO 10497)	
National Board	ASME / UV	
AQSIQ	CCC	
DIN GOST TÜV	EAC	
TSSA	CRN	
AAR		

## Classification societies



Bureau Veritas



China Classification Society



Det Norske Veritas/  
Germanischer Lloyd



Lloyd's Register



Russian Maritime Register of Shipping

The following Conditions shall apply for all purchase contracts and contracts for work and services between us and our commercial contract partners (hereinafter referred to as: the Customer) as well as for our offers, even if we do not explicitly refer to these in individual cases. Deviations from these shall only be binding for us if we have explicitly confirmed this in writing. The Customer's purchasing terms and conditions shall not be binding for us, even if we do not explicitly object to these.

## 1. Offer and conclusion of order

Our offer remains non-binding with regard to the price, quantity, delivery data and possibility of delivery until the order has been confirmed in writing. Ancillary agreements shall only be effective if we have confirmed these in writing.

## 2. Scope of delivery

The scope of delivery is finalised in the confirmation of the order. For goods which are not catalogue items, a tolerance in the quantity of 10% more or less items is permitted.

## 3. Delivery and delivery periods

The delivery period commences when all details of the order have been confirmed, however not until the fulfilment of the Customer's contractual obligations. The delivery period shall be deemed to have been completed if the goods have left the warehouse prior to its expiry, or, if dispatch is delayed for reasons for which the Customer is responsible, with the notification of readiness for dispatch within the agreed delivery period.

Compliance with the delivery period is conditional on correct and timely deliveries to us.

Partial deliveries which are in good time and in suitable quantities are permissible and can be invoiced separately.

If the fulfilment of our obligation for delivery is prevented by force majeure, labour disputes or other events which are not within our sphere of influence - regardless of whether these occur with us or our sub-suppliers - the fulfilment of our obligation for delivery shall be extended for the duration of the disturbance. If delivery is rendered impossible due to such an event, or is not reasonable for one of the parties, both parties shall be entitled to withdraw. In case of arrears or impossibility of delivery for which we are responsible, the customer shall be entitled to withdraw the order according to the statutory conditions. Art. 14 of these Terms and Conditions shall apply in the case of claims for compensation.

If dispatch is delayed at the wish of the customer, commencing one month after notification of readiness for delivery, the costs which are incurred due to storage, however at least 1% of the invoiced amount shall be invoiced to the customer.

## 4. Prices

All prices are ex stock plus the statutory VAT. The prices which are valid on the day of delivery apply. Packaging, loading costs, customs duties etc. shall be borne by the customer.

## 5. Shipping

Dispatch and shipping of the goods shall be at the account and risk of the customer.

## 6. Transfer of risk

The risk shall be transferred to the customer as soon as the goods have left our company. If the dispatch of the goods is delayed due to the customer, the risk shall be transferred with the notification of readiness for delivery.

## 7. Terms of payment

The invoiced amounts are payable in cash within 14 days after the date of the invoice with 2% discount of the net value of the goods, or within 30 days without deduction. Discounts may not be deducted for new invoices, as long as older invoices which are due for payment have not been settled.

In case of arrears or for the time of deferment of receivables, the statutory interest on arrears shall be charged, regardless of any further claims for compensation. If it becomes apparent subsequent to the conclusion of the contract that our claim for payment is endangered by lack of solvency on the part of the Customer, all of our outstanding invoices shall become due for payment immediately. In this case, we shall be entitled to make outstanding deliveries conditional on cash payment or the provision of a security. Any further statutory claims shall remain unprejudiced by this. Offsetting is only permissible with regard to undisputed or legally established counterclaims. The Customer is only entitled to exercise a right of retention if the claim is based on the same contractual relationship.

The same shall apply for the retention of payments.

## 8. Reservation of title

Goods which have been delivered remain our property until payment of all of our outstanding claims, including ancillary costs and interest. This shall also apply to the cashing of cheques for payment of such claims. In case of current accounts, the reservation of title is deemed to be security for our balance claim. Modification or processing of the goods subject to reservation of title shall be performed on our behalf, without this giving rise to any obligations for us.

In the case of processing, combination or mixing of our goods with other goods which are not our property, we shall be entitled to co-ownership of the new goods in the relationship of the invoice value of the goods subject to reservation of title to the value of the other processed goods at the time of processing, combination or mixing. If the Customer obtains the sole ownership of the new goods, he herewith transfers co-ownership of the new goods in the relationship of the other processed goods at the time of processing, combination or mixing and shall keep the said goods on our behalf with due business diligence.

Resale of the delivered goods, regardless of whether these are unprocessed, or have been processed, combined or mixed is only permitted in the normal course of business with reservation of title, and only then, if the claims resulting from the resale are ceded to us. The Customer is prohibited from pledging or transferring the goods as security, as is the agreement of a prohibition of assignment and an assignment without our consent in the context of factoring. The Customer shall inform us without delay in case of seizure or any other impairment of our entitlements by third parties. The Customer hereby assigns to us in advance, all claims to which he is entitled now or at a later date from the resale or for whatever legal reason with regard to the goods which we have delivered. We accept the said assignment. The value of the goods subject to reservation of title is our invoice amount plus a security surcharge of 10%, which however remains without effect if this is precluded by the rights of third parties. In the case of resale of our goods after processing, combination or mixing, or the resale of the new goods which result from processing, combination or mixing, the claim against the Customer's buyer shall be assigned to the amount of the invoice value of our processed, combined or mixed goods. This shall also apply in the case of resale after our goods have become an essential part of another good after combination or processing with other goods which are not our property. If the value of the securities which are provided to us exceeds a total of 10%, we shall be obliged to release securities of our choice if so requested by the Customer. With the payment of our claims, ownership of the goods subject to reservation of title and the assigned claims shall be transferred to the Customer. Until this is revoked by us, the Customer is entitled to collect the purchase price on our behalf. On demand, the Customer shall be obliged to notify the assignment to his buyer and to provide the necessary information and to surrender the documents which are necessary for us to enforce our claims against the said buyer.

## 10. Liability for defects

The warranty rights of the Customer are conditional on him having fulfilled his obligations for examination and complaint according to Art 377 HGB (German Commercial Code).

Increases or reductions in weight due to the casting process do not entitle the Customer to complain. If the item being purchased is defective, we can remedy the defect or deliver a replacement, at our discretion. If we remedy the defect, we shall bear all expenses necessary to remedy the defect, especially the costs of transport, travel, work and material unless they are increased due to the fact that the item being purchased was taken to a place other than the place of performance. The Customer may withdraw from the contract or demand a reduction if after having been set a reasonable period of grace we fail to provide a subsequent delivery or correction, if correction has finally failed, if we refuse the said correction or if this is unreasonable to the Customer. If there is only an insignificant fault and the goods can be utilised by the Customer without disadvantage, he is only entitled to a reduction in the purchase price.

For new products, the warranty period is 1 year from the date of delivery. No warranty is assumed for used products. The period of limitation in case of a delivery recourse according to Art. 478, 479 BGB is not affected by the regulations of the two previous provisions. Compensation claims due to an injury to life, limb or health which are due to a fault, or according to product liability law are also not restricted by the aforementioned regulations. Other claims for compensation under warranty law are also not restricted by this regulation in the case of gross negligence, wilful action or breach of major contractual obligations. Clause 14 of these Terms and Conditions applies.

## 11. Return delivery

Return deliveries which are not based on a legal claim may only be made with carriage paid with our explicit consent. As compensation for the costs which we incur for any return delivery, we reserve the right to an appropriate deduction from the net value of the goods in the credit note of at least 20% of the net value of the goods.

## 12. Catalogues

Illustrations in our catalogues and brochures are not binding with regard to the design. We reserve the right to changes to the design, insofar as these is necessary for technical reasons and do not impair the purpose of the contract. Deviations from the specified dimensions and weights are permissible, if the said do not impair the contractual purpose and quality.

## 13. Copyright

We reserve ownership and copyright for catalogues, illustrations, drawings, samples and other documents. These may not be made accessible to third parties without our consent and must be returned to us immediately on demand. If an order which is placed with us on the basis of submitted drawings or models infringes against third party patent rights, design rights or trademarks, the Customer shall bear all responsibility for this and shall be liable to us for any claims for damages or loss of profit and shall indemnify us against any claims by third parties, unless he is not responsible for the infringement.

## 14. General liability

We shall only be liable in the case of wilful action or gross negligence. In the case of a breach of major contractual obligations we shall also be liable for simple negligence. Major contractual obligations are those, whose fulfillment enables the proper fulfillment of the contract and on whose fulfillment the purchaser may normally rely and does rely. Except for the case of wilful intent, our liability shall be restricted to damage which is typical for the contract and which is reasonably foreseeable.

The aforementioned limitation of liability shall not apply in the case of injury to life, limb or health and in cases of liability under product liability laws.

The Customers claims for the compensation of expenses pursuant to Section 284 BGB are excluded to the extent that the claim for damages in lieu of performance is excluded pursuant to the foregoing provisions. The aforementioned restriction of liability shall also apply in favour of our employees, bodies and other agents.

## 15. Place of performance, place of jurisdiction, applicable law, miscellaneous

The place of performance for all claims arising from this contract is our registered office. The place of jurisdiction for all disputes with businessmen, legal entities under public law or special funds under public law, or with persons who do not have a general jurisdiction in Germany, is our registered office. However, we are entitled to bring an action against the Customer at the Customers registered place of business.

These Conditions shall be governed by the laws of the Federal Republic of Germany to the exclusion of the UN Convention of the International Sale of Goods (CISG).



## CRYOGENIC



### Globe valves, control valves, check valves and fillsystems for Cryogenic Service

Media: liquefied gases such as oxygen, nitrogen, argon, krypton and LNG  
 Sizes: DN10 (3/8") to DN50 (2") (gunmetal/brass)  
 DN10 (3/8") to DN200 (8") (stainless steel)  
 Temperature: -255°C (-427°F) to +120°C (+248°F)  
 Pressure: up to 50 bar (725 psi)



### Safety valves for Cryogenic Service

Media: liquefied gases such as oxygen, nitrogen, argon, carbon dioxide and LNG  
 Sizes: DN6 (1/4") to DN50 (2")  
 Temperature: -270°C (-454°F) to +400°C (+752°F)  
 Pressure: 0.2 bar (3 psi) to 250 bar (3626 psi)

## INDUSTRY



### Safety valves for gases, vapours and fluids

Media: Gases, vapours, fluids, liquefied gases, refrigerants and dusty media  
 Sizes: DN6 (1/4") to DN50 (2")  
 Temperature: -270°C (-454°F) to +400°C (+752°F)  
 Pressure: 0.2 bar (3 psi) to 250 bar (3626 psi)



### DIN EN valves made of gunmetal/brass

Media: non-flammable and non-toxic fluids, gases and vapours  
 Sizes: DN6 (1/4") to DN150 (6")  
 Temperature: -10°C (+14°F) to +200°C (+392°F)  
 Pressure: up to 16 bar (232 psi)

## ENERGY



### Drain valves, three-way valves, ball valves and gate valves for oil-immersed transformers

Media: Transformer oil  
 Sizes: DN15 (1/2") to DN250 (10")  
 Temperature: -50°C (-58°F) to +120°C (+248°F)  
 Pressure: up to 16 bar (232 psi)

**HEROSE GMBH**  
**ARMATUREN UND METALLE**

Elly-Heuss-Knapp-Strasse 12  
23843 Bad Oldesloe  
Germany

Phone: +49 4531/509-0  
Fax: +49 4531/509-120  
info@herose.com

