

Ortlinghaus

Prop.*act*



Ortlinghaus Group.

For more than 75 years, we have specialized in marine technology. Today we offer the complete product range from plates, clutches, and clutch systems in ship drives to brakes in deck machinery.

We are the only manufacturer that combines many years of highly successful experience in the design of clutches with the in-house production of plate linings. The quality of Ortlinghaus has an outstanding reputation throughout the world – and we feel obliged to maintain it. Together with our customers, we develop individual solutions that stand out as a result of innovative capacity and superior engineering.

With **Prop.act** – our shifting clutch system – we have taken another step toward the future. The hydraulically actuated, wet-running clutch unit with shaft end connections on both sides, integrated oil supply and hydraulic control can be installed on a ship as a ready-to-use compact unit. A stand-by pump is additionally installed, that keeps the system self-contained at any time.

There are numerous application areas for this self-contained clutch unit. It functions as a connecting unit between the engine and the above-water gearbox – for instance, in drive lines of rudder propellers – and for hybrid solutions as a connection between main diesel engine and electric motor in order to connect the propeller shaft, for working ships, tugboats, supply ships, yachts, passenger ships, and ferries. Trolling mode is possible, if required.

Prop.act impresses with a series of technical innovations and advantages, which make it efficient and economical to use.

Ortlinghaus

Founded in:	1898
Employees:	> 550
Subsidiaries:	Ortlinghaus (U.K.) Ltd. / England Ortlinghaus France / France Ortlinghaus AG / Switzerland Ortlinghaus Drive Technology (Shanghai) Co., Ltd / China Ortlinghaus Drive Technology India Pvt.Ltd. / India OOO „Ortlinghaus RUS“ / Russia
Manufacturing:	Wermelskirchen / Germany Gams / Switzerland Shanghai / China
Sales:	Worldwide via agencies

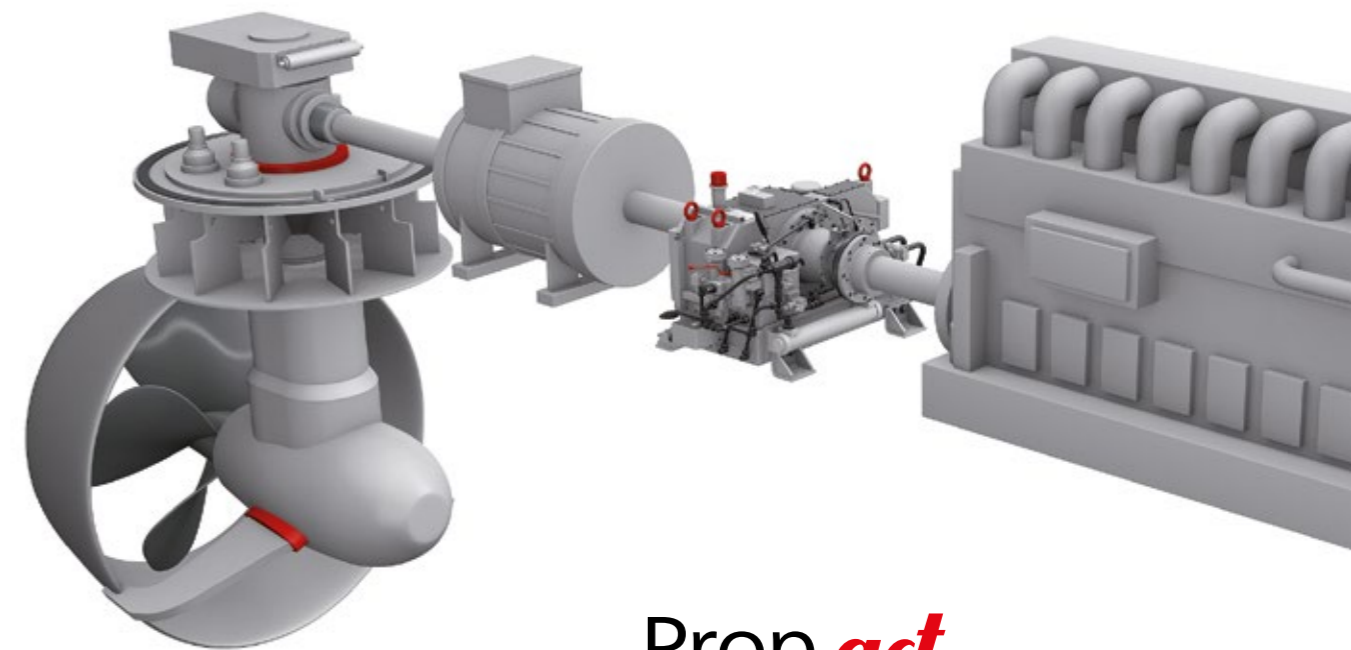

Prop.act

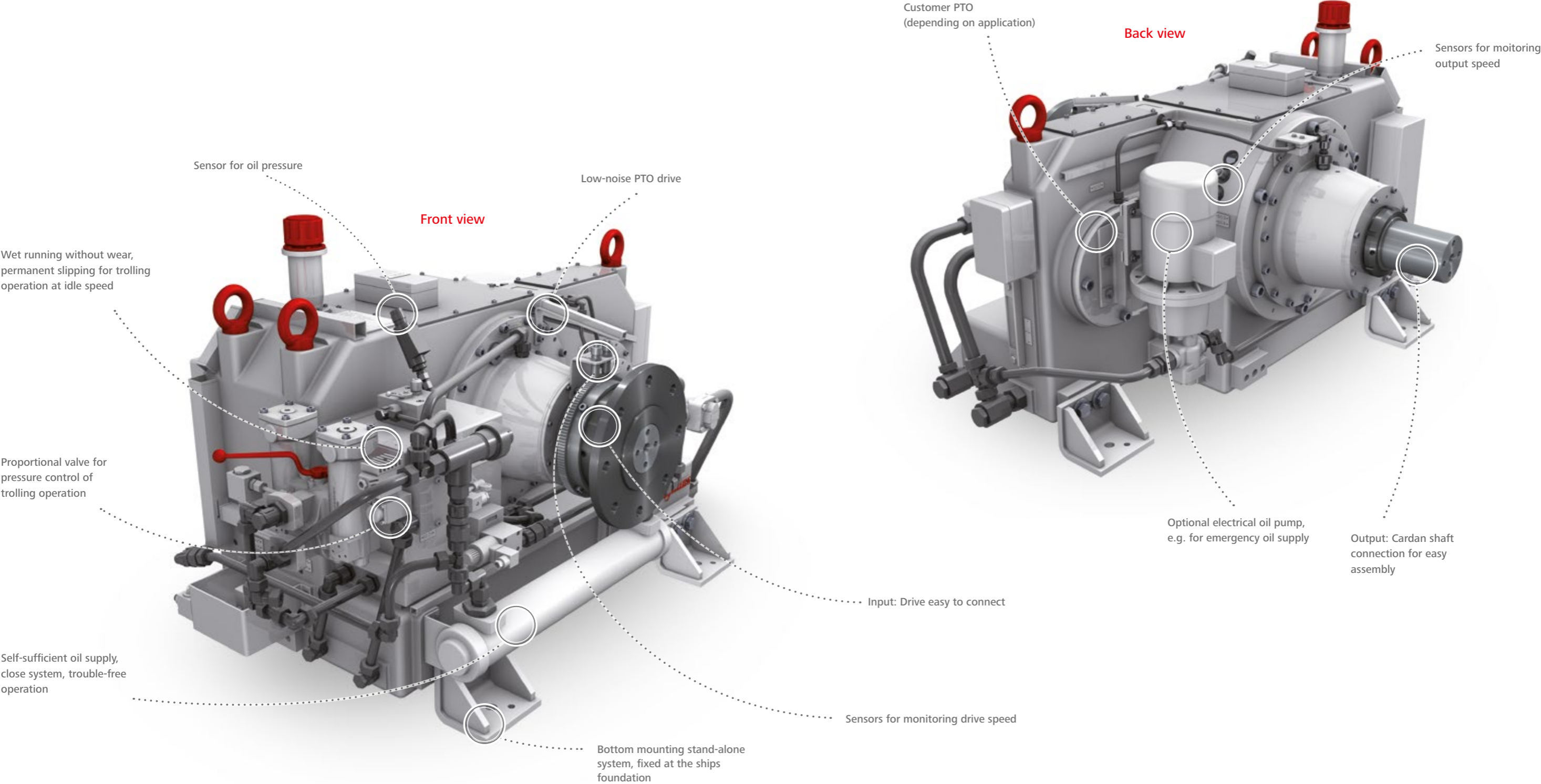

Drive train concepts.

| Conventional drive technology with Prop.act

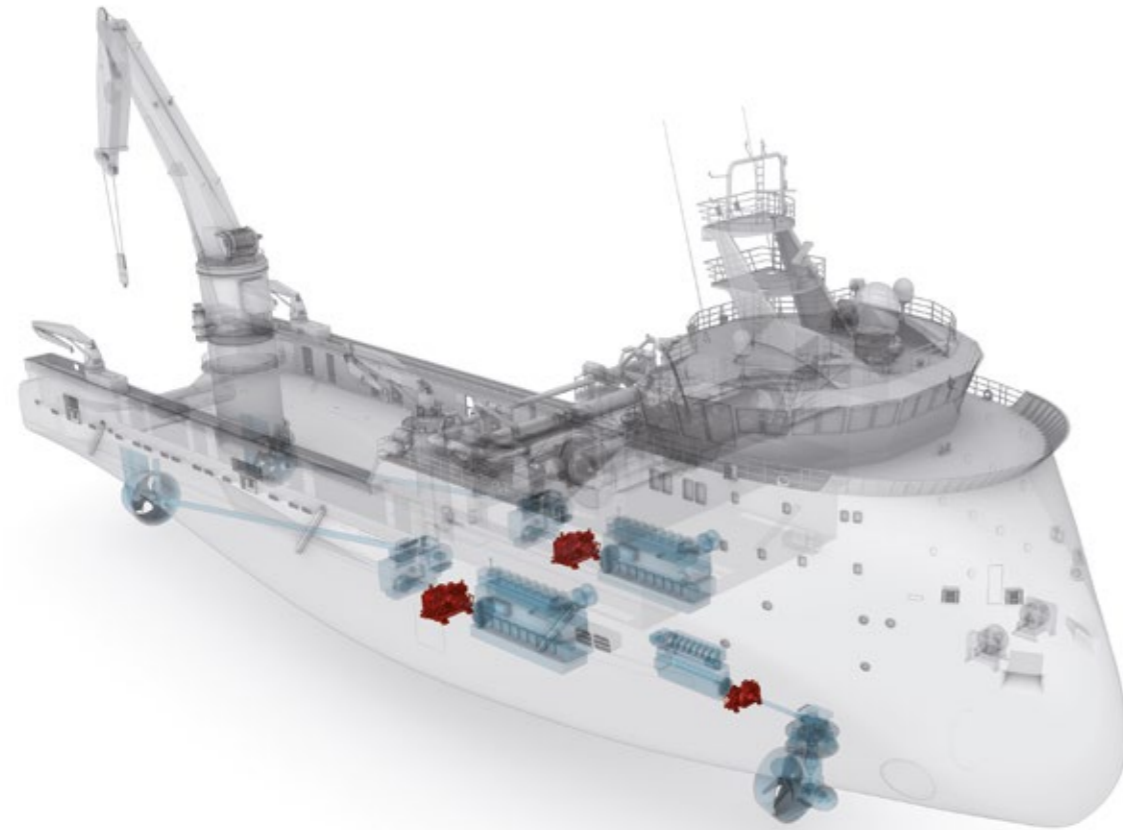

Prop.act in conventional main drive

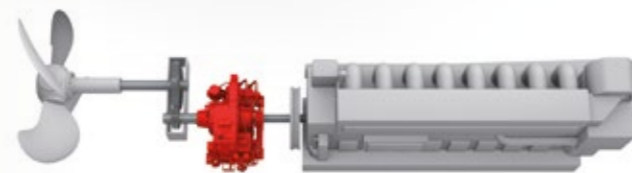

Prop.act in conventional z-drive

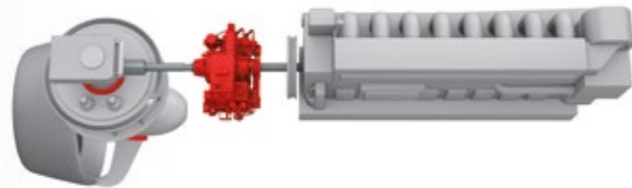

| Hybrid drive technology with Prop.act

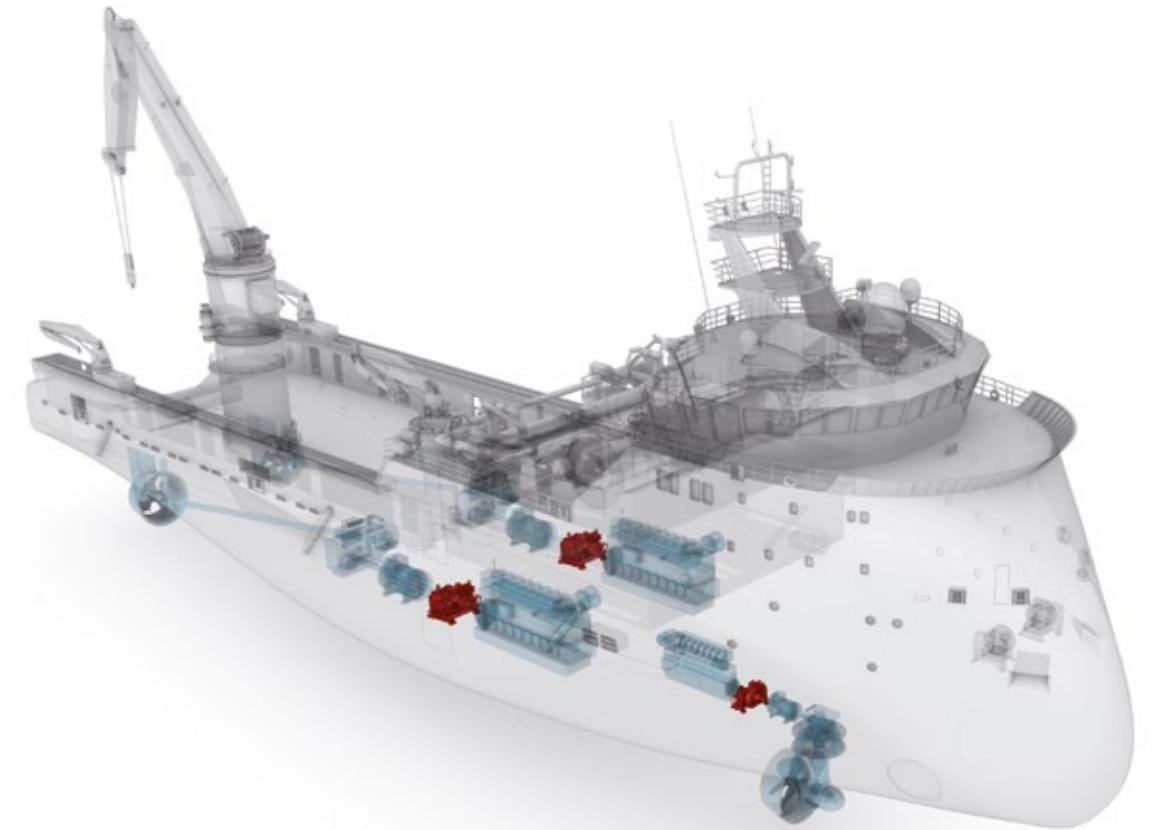

Prop.act in hybrid main drive



Prop.act in hybrid z-drive

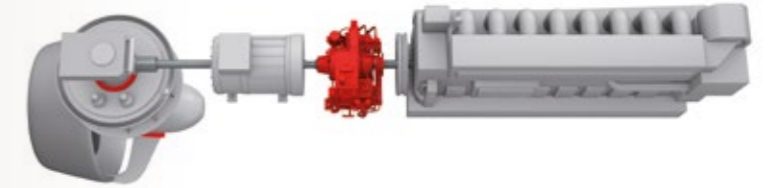

Prop.act

- T** Torque: 13,500-24,670 Nm
- n** Speed: 1,200-1,800 rpm
- P** Power: 2,500-3,100 kW
- P/n** Ratio: 1,4-2,6
- PTO** PTO-Power: 40-70 kW

- n** Engine / idle speed: 500-750 rpm
- n** Output speed: 750-100 rpm
- Δn** Differential speed: 650-0 rpm
- P** Cooling Power: 24-100 kW
- t** Max. water temperature: 38 °C
- v̇** Min. water flow: 3,5 m³/h

Trolling operation
Prop.act

Prop.act – our shifting clutch system is a hydraulically actuated, wet-running clutch unit. It is a stand-alone system, which is bottom mounting. Within the drive train it can be connected between two shaft ends of the cardan shafts for example.

Prop.act impresses with a series of technical innovations and advantages, which makes it efficient and economical to use.

The **Prop.act** clutch system can be applied in hybrid propulsions between the E-engine and the diesel engine for example. In this case the power take off can't be used because a stand by pump has to be installed

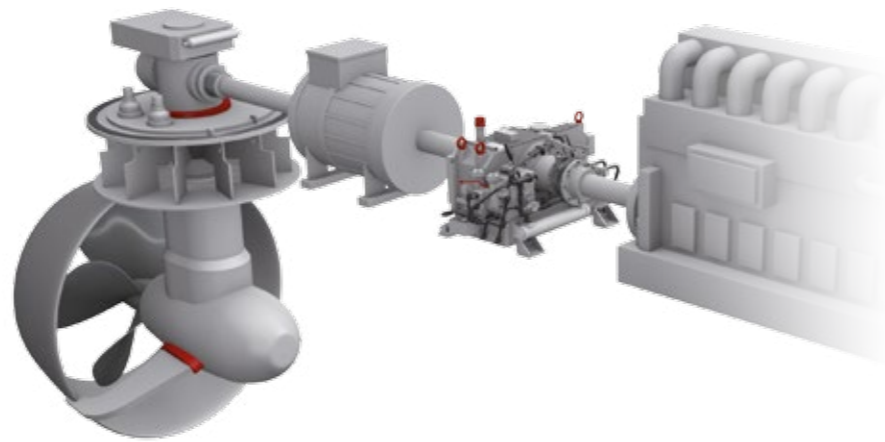

	Technical data Prop.act		
	Series	66	72
Power _{max.}	kw	2,500	3,100
Speed _{max.}	1/min	1,800	1,200
Torque engine _{max.}	Nm	13,500	24,670
Operating pressure	bar	25	27
P/n	kW/min	1,4	2,6
PTO-Power	kW	40	70

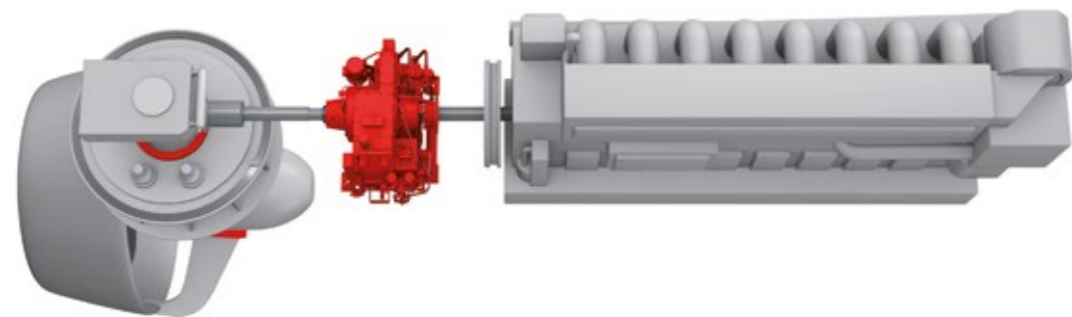

The trolling mode allows very fine adjustment of the propeller speed due to the slipping capabilities of the **Prop.act**. The wet running system ensures wear-free operation and trolling within defined technical limits. The minimum output speed while slipping is 100 rpm. During trolling operation the output speed covers a range of 750 to 100 rpm while the engine runs constantly at idle speed. From engine idle speed to maximum speed the clutch is fully engaged.

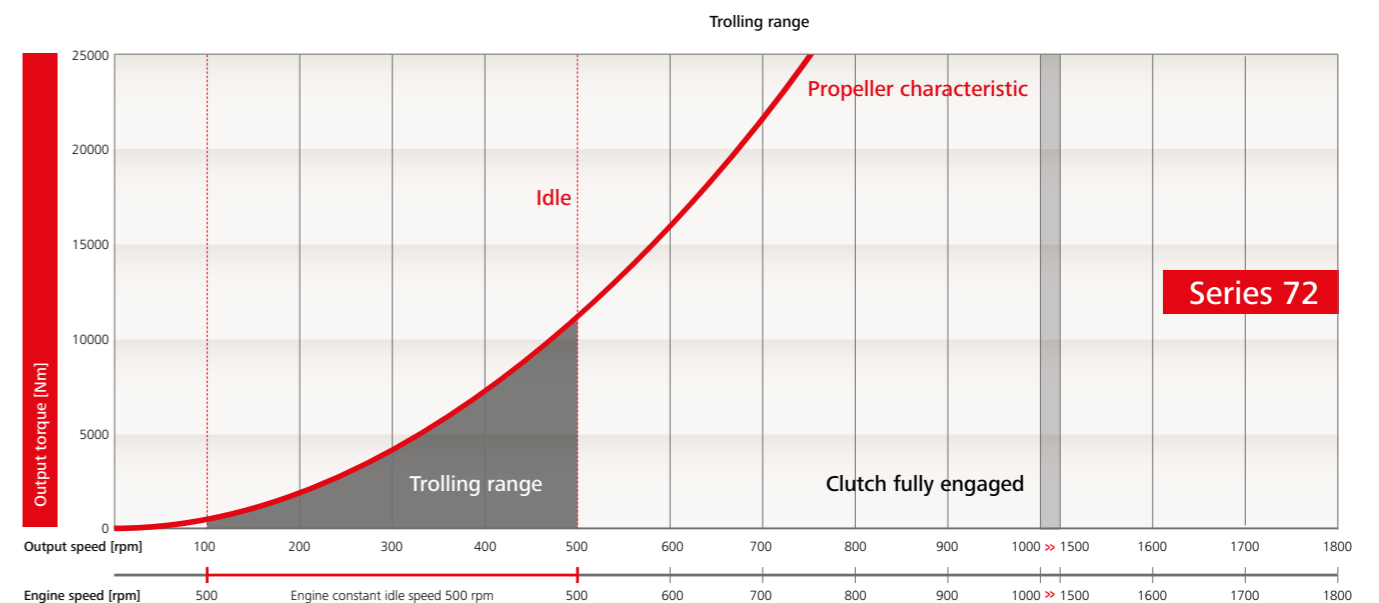
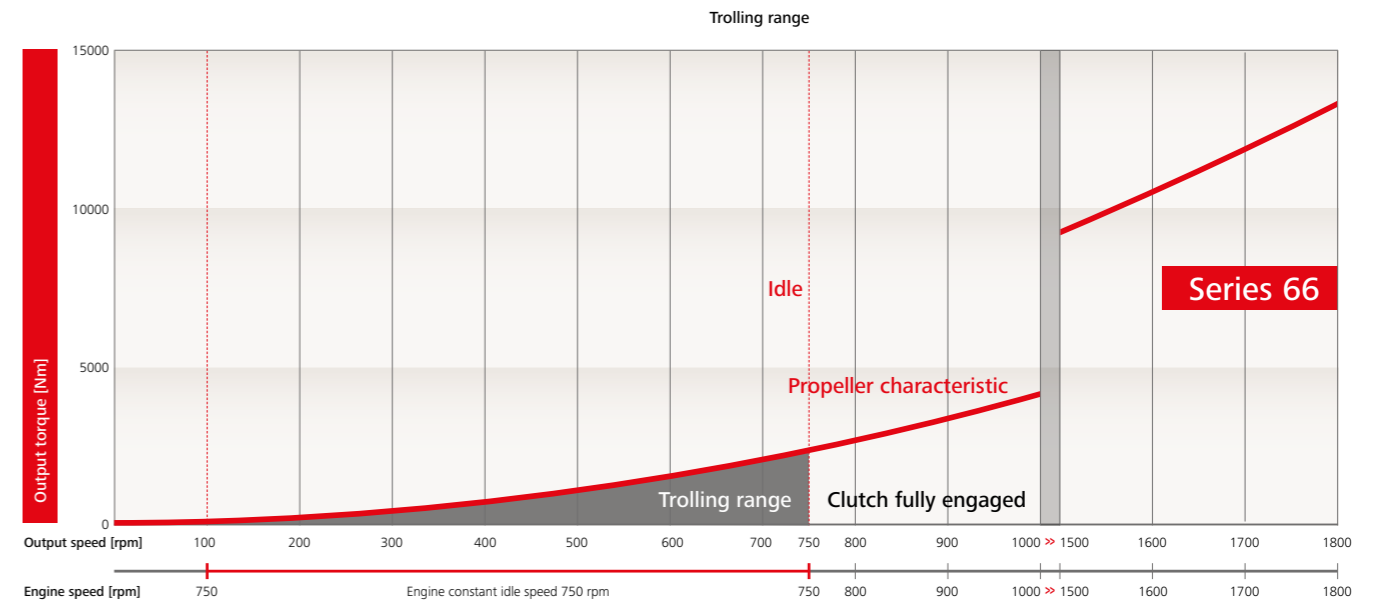

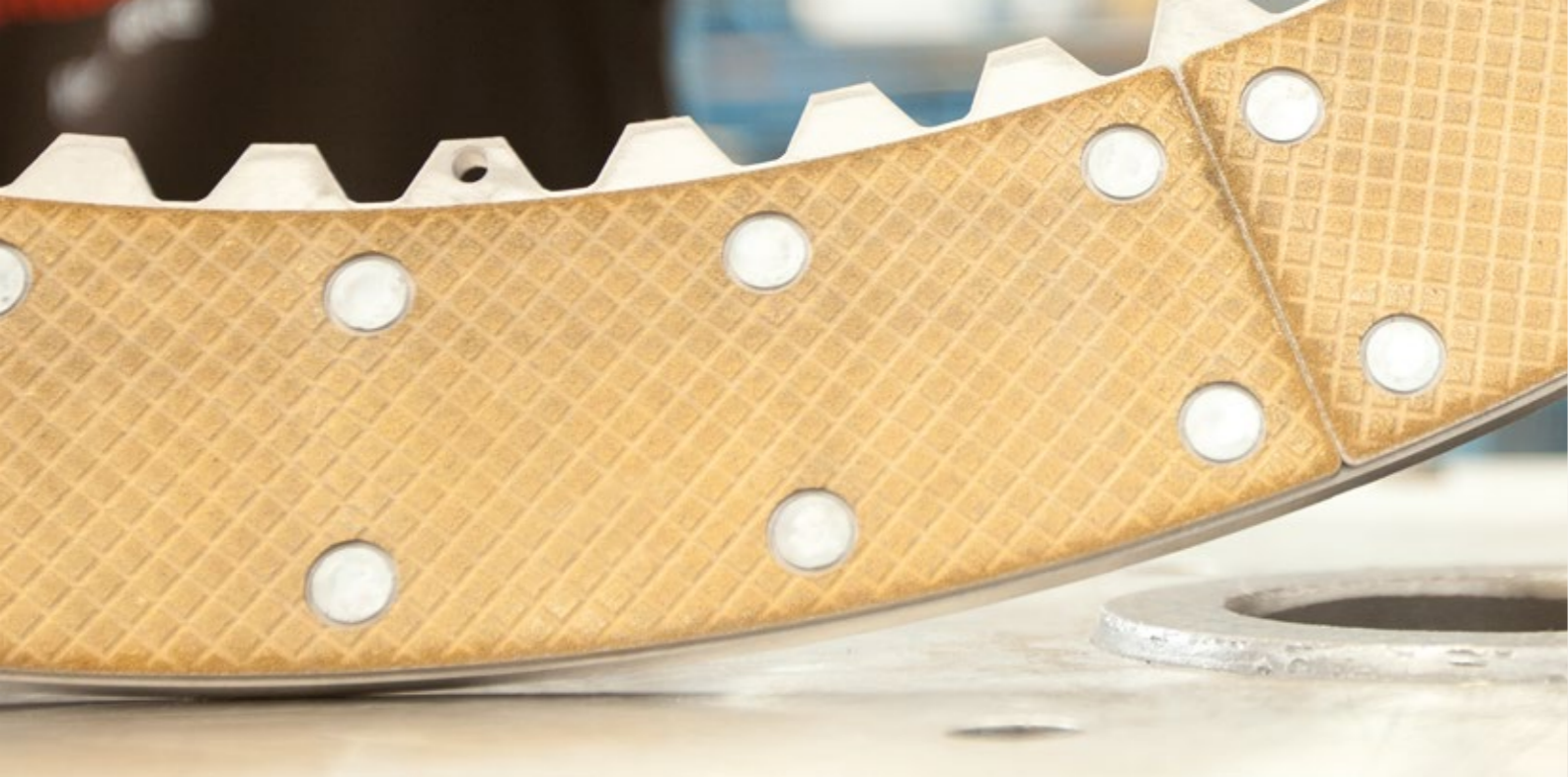

Auxiliary Output

Prop.act's design facilitates the simple assembly of an additional auxiliary output, e.g. for a variable pump for rotating the rudder propeller.

Noise

The operation of **Prop.act** generates little noise. The auxiliary output takes place by way of a chain drive and is surprisingly quiet, according to feedback from our customers.

The Essential Advantages.

Prop.act is a system that can directly and positively influence the main factors of your equipment effectiveness. It achieves this by reducing or avoiding the main productivity losses of standard

products. This in turn results in a higher equipment availability, an increased performance rate and an improved quality rate.

Efficiency

Prop.act is a sophisticated end-to-end system, which has many advantages and can increase the overall equipment efficiency.



Wear-free system

The wet-running sinter lining of the clutch ensures wear-free operation and problem-free trolling (within defined technical limits).



Integrated Oil Supply

The supply of pressure oil and cooling oil is integrated with a built-in oil tank. As a result, no external controls are required and separate pumps, valves, and heat exchangers are made superfluous.

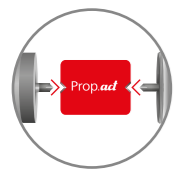

Easy Assembly

This self-sufficient system with integrated cooling oil, circuit tank, monitoring allows a plug-and-play operation. Defined drive interfaces enable simple assembly of the drive shaft through adjusted connection dimensions. In addition,

defined connection dimensions in the take off interfaces guarantee optimal connection to the gearbox.



Integrated Sensors

Built-in sensors produce all necessary signals for operation and monitoring, like input/output speed, temperature and pressure setup: This eliminates the need to install additional sensors and makes overall installation much easier.



Performance range

Broad range power range for various ship types trolling operation: Permanent slipping at idle speed for trolling operation.

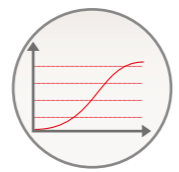

Durability

The sum of all these features is a robust system and a prolonged lifetime due to systems design coming from one developer.

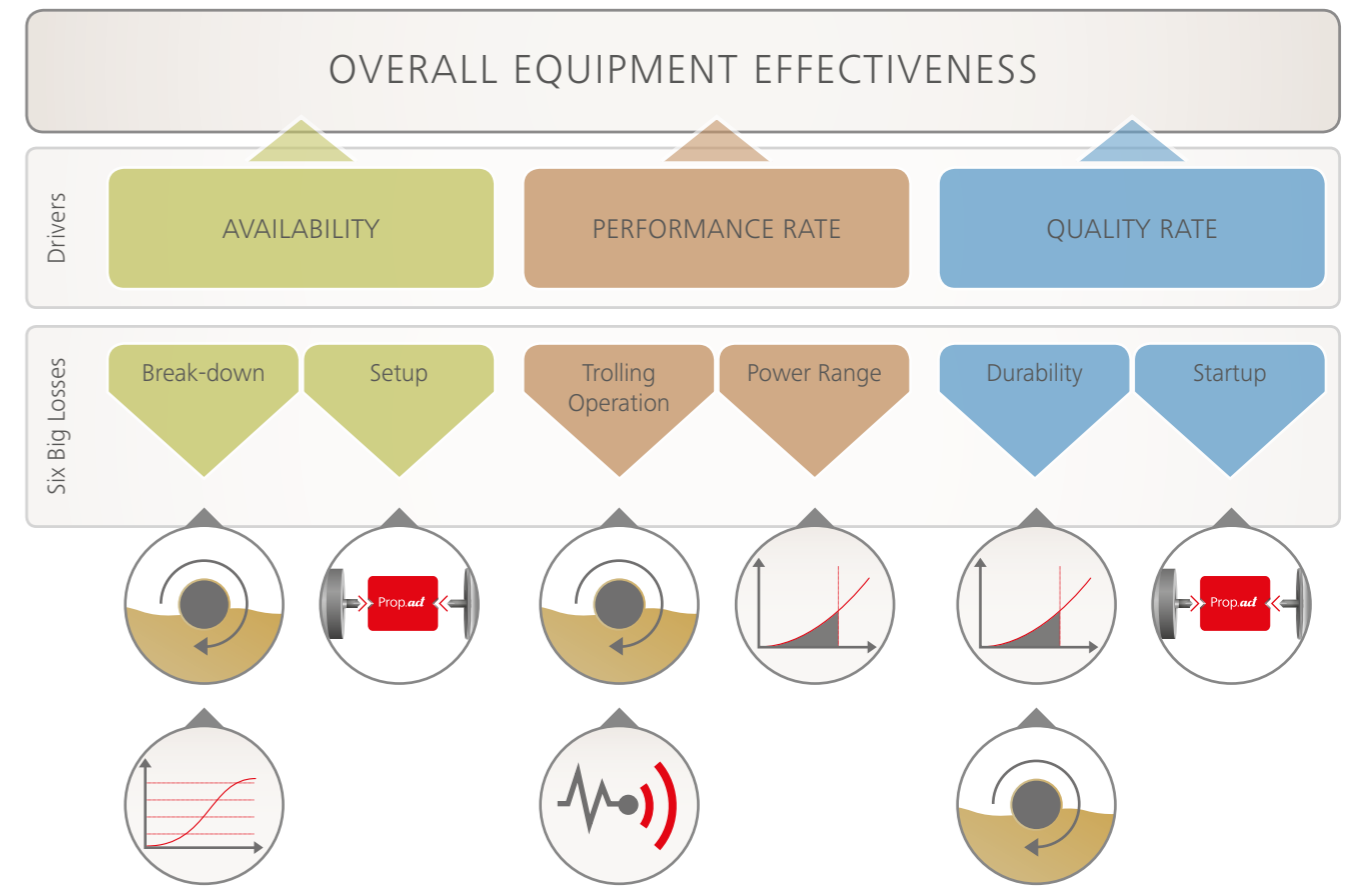

Ortlinghaus Innovations Process.

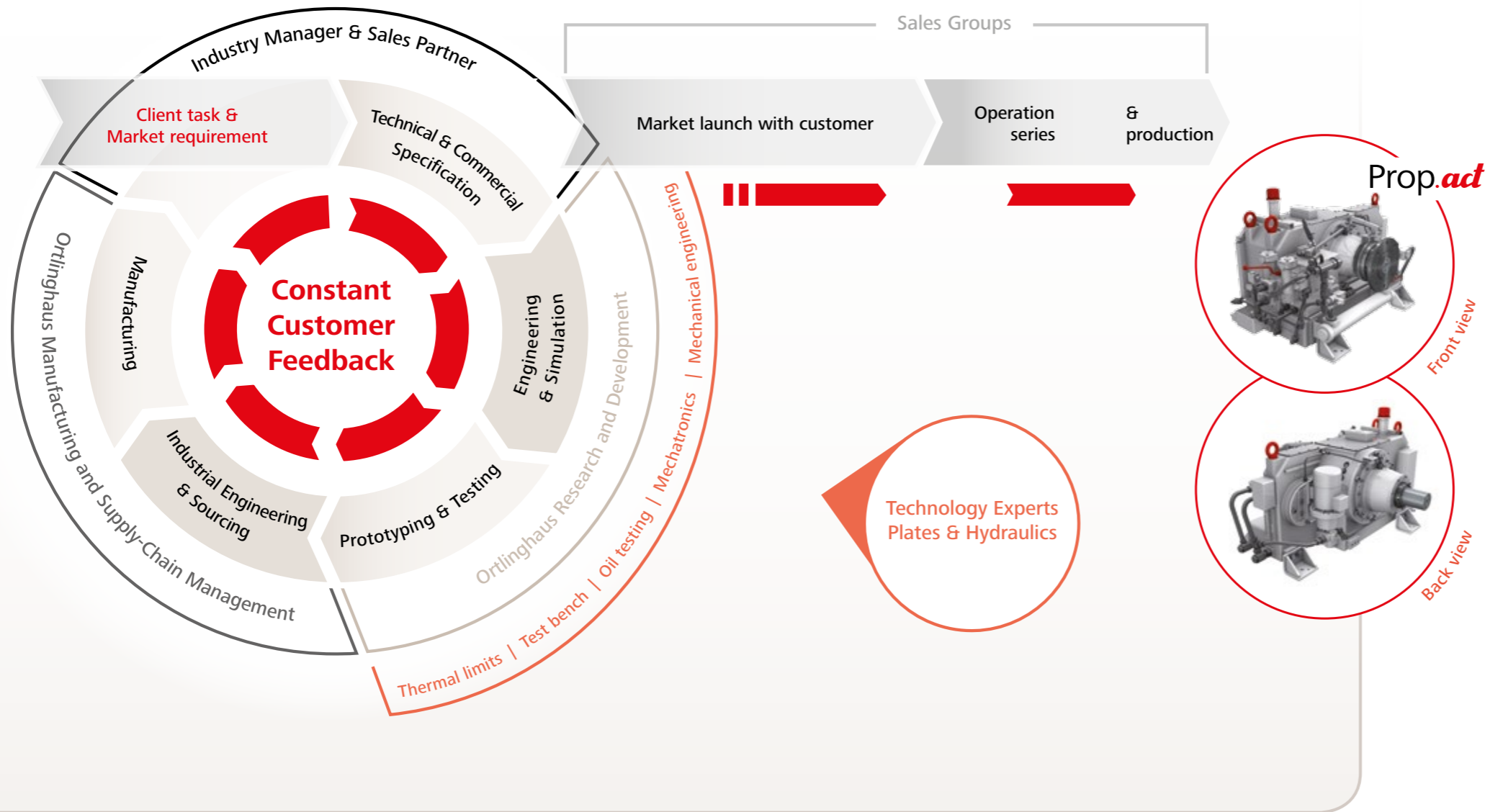

Product development

Practical experience and cumulative expertise from 75 years in marine technology are the foundation for our success. **Prop.act** is a new product development that needed less than a year to advance from conception to the start of production. It is the result of the close collaboration with a customer, Ortlinghaus branch management, and the R&D department.

Providing pressure and cooling oil is an integral part of product development. This dispenses with the need for external hydraulic actuators including piping and separate pumps and valves.

Another major factor is our high degree of integrated value creation: Manufacturing all of the relevant components of **Prop.act** ourselves significantly expedites the development process.



Quality, Health, Safety and Environment.



An integrated management system (IMS) that takes into account all processes is the basis for Ortlinghaus' corporate policy. Quality, occupational health and safety, and environmental protection play crucial roles for our company.

We have analyzed and documented all relevant processes in the value chain. Our IMS is based on the resulting summary of process descriptions, plans, procedures and guidelines as well as the Ortlinghaus Management Manual.

The management system is the basis for all business activities in our company and for our relationship with our customers. It ensures that all customer-oriented product and manufacturing specifications are reflected in elaborate instructions regarding

quality assurance and quality control and that they comply with the relevant operating instructions and quality standards of the Ortlinghaus Management System.

Our quality management system is based on the ISO 9001 standard. In the area of environmental protection, we are certified at the Wermelskirchen site according to ISO 14001. In energy management, we are certified according to ISO 50001.

Ortlinghaus assigns the highest priority to occupational health and safety. We live up to our principles in this area in our daily conduct. At Wermelskirchen, we are currently working toward ISO 18001 certification.

Our goal is to minimize the impact of our activities on the environment. For this reason, all employees of the Ortlinghaus Group have committed themselves to complying with essential environmental guidelines. In addition, all our processes in Wermelskirchen are certified accordingly.

We are convinced that long-term success can be achieved only through the right balance of economic, ecological and social conduct.

We certify our products according to your specifications (e.g. DNV-GL, Lloyds Register and CCS).



Ortlinghaus-Werke GmbH
Kenkhauser Str. 125
42929 Wermelskirchen
Germany

Phone: +49 (0)2196 85-0
Fax: +49 (0)2196 855-444

info@ortlinghaus.com
www.ortlinghaus.com