

Turning Power into Motion.
Product catalogue.

Linde Hydraulics

Linde



COMPANY		VALVE TECHNOLOGY	
EDITORIAL	03	LSC LINDE SYNCHRON CONTROL-SYSTEM	24
PARTNERSHIP	04	LSC VALVE TECHNOLOGY	27
SERVICE CENTER	05	VT MODULAR	28
HIGH PRESSURE HYDROSTATICS		MONOBLOCK	29
SERIES 02	06	SWING DRIVE SOLUTIONS	
HPV-02 VARIABLE DISPLACEMENT PUMPS	08	SWING DRIVE SOLUTIONS	30
CONTROLS	09	HMF-P SWING DRIVE MOTORS	31
HPR-02 SELF-REGULATING PUMPS	10	ELECTRIC COMPONENTS	
SPU NOISE OPTIMIZATION	11	LINTRONIC	32
HMV-02 VARIABLE DISPLACEMENT MOTORS	12	ELECTRONIC CONTROL UNITS	33
LOW SPEED CONCEPT	13	PERIPHERAL EQUIPMENT	34
HMR-02 SELF-REGULATING MOTORS	14	PERIPHERAL EQUIPMENT AND SENSORS	35
PTO THROUGH-DRIVE MOTORS	15	LINDIAG [®] -SOFTWARE	36
HMF-02/HMA-02 FIXED DISPLACEMENT MOTORS	16		
MULTIPLE UNITS	18		
K-02 UNITS	20		
MEDIUM PRESSURE HYDROSTATICS			
MEDIUM PRESSURE PUMPS	22		
MPR 50 OPEN CIRCUIT	23		

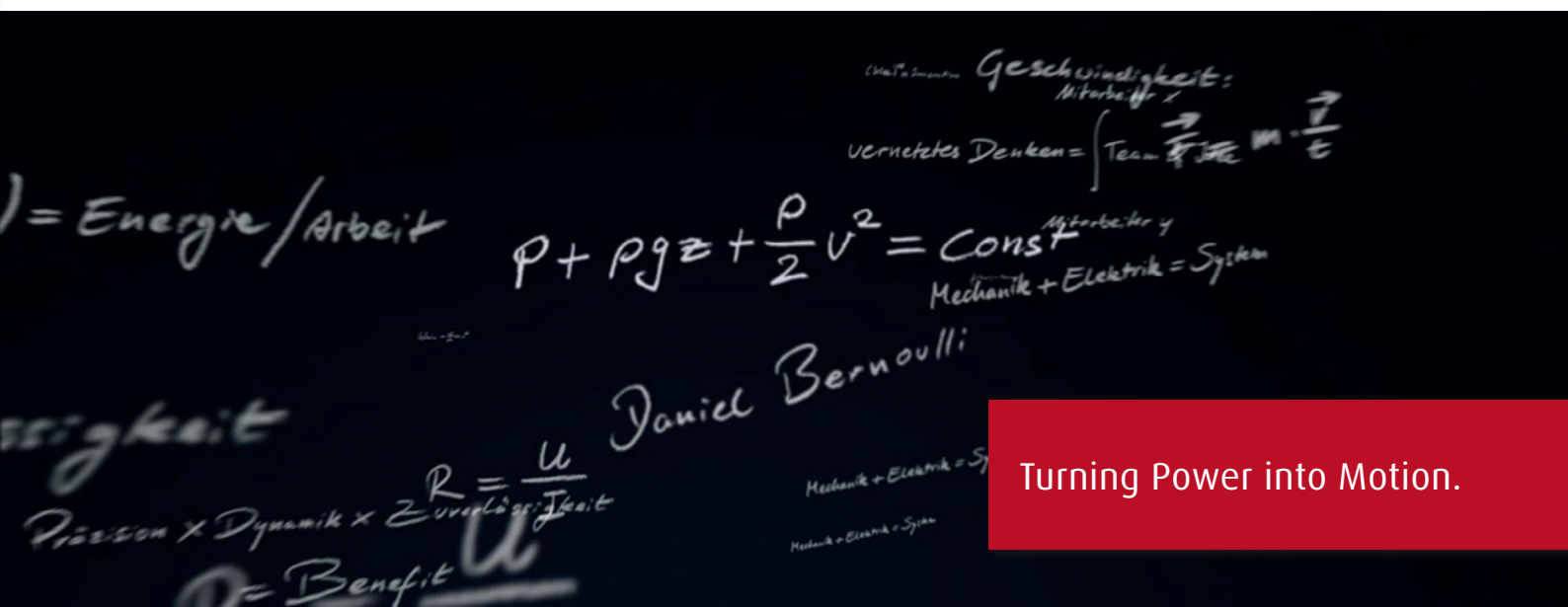

Turning Power into Motion.

A formula that remains valid for the future.

The world is characterised by change, an increase in task volumes and new challenges. We are rising to the challenges posed by these global issues, and are actively shaping the associated changes. Our business activities are governed by the issues of reducing CO2 and saving fuel.

We have always had a passion for converting power into motion, and this passion is driven by customer care, a thirst for knowledge and a love of innovation.

We combine components into a single system and create efficient overall solutions thanks to our intelligent blend of hydraulics, electrical engineering, electronics and mechanics. Our aspiration can be summed up by one simple concept:

We insure added value for our customers which is tailored to the customer and can be maintained over the long term. Experience, system expertise and the pursuit of perfection form the basis for our joint success.

Linde Hydraulics makes all of this possible thanks to a combination of partnership, overall responsibility and the highest level of commitment. We power ideas, machines and markets, both today and in the future.

This explains our formula: Turning Power into Motion.
Linde Hydraulics.



Partnership. Common success counts.

For Linde Hydraulics, partnership is an important, indispensable part of the product development and quality assurance. We add value through our knowledge, expertise and international market experience in all phases of customer projects.

Our interpretation of customer orientation is permanent availability. We are focused on offering solutions while accompanying customers from the initial product idea stage all the way through project engineering, product development, prototype commissioning and to the ultimate goal: the start of production.

Additional services include comprehensive customer staff trainings to provide the best transfer of product and system knowledge. You can rely on our partnership for your success.

Our team of experts supports you with enthusiasm and competence in optimizing your hydraulic systems. Any time. Worldwide.

Your advantages

- worldwide project support
- common product development
- specific customer seminars
- motivated staff training
- customized project coaching
- system training for specific applications



The dialogue between client and Linde Hydraulics is the focal point of attention: whether on customer seminars, staff training for our customers or project coaching on Linde hydraulic components and LinTronic – experts on both sides exchange their views. Together for more market-success.



The Linde Hydraulics Service Center offers their customers reliable remanufacturing and rebuilding service worldwide. Warranty in Linde Quality.

Service Center. Reliability counts.

With customer service, repairs and remanufacturing, our service program leads the way. Our experienced team of experts is by your side any time to provide quick and competent support. Best service counts.

Our sales organization is always connected online with the global spare parts facility in Germany that you can get original Linde spare parts quickly and easily worldwide.

Our Service

- parts availability in Europe within 24 hours
- repair service
- remanufacturing with “as new” warranty



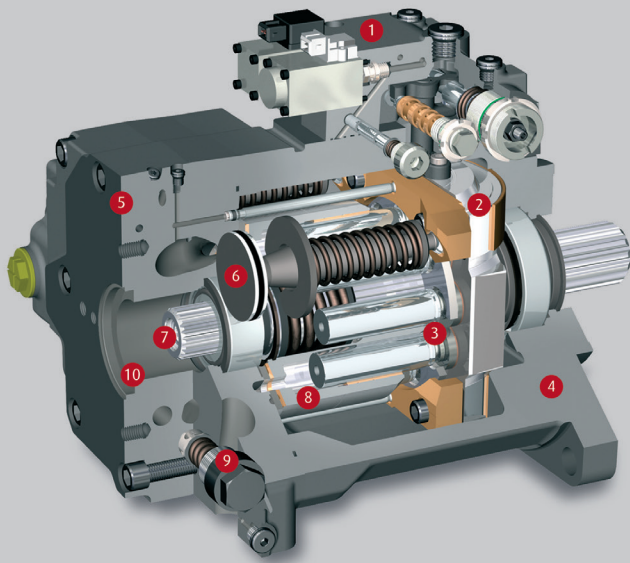

Design characteristics Series 02

1	Control device	modular design, precise and load-independent
2	Swash plate	hydrostatic bearing
3	Piston-slipper assembly	21° swash angle
4	Housing	monoshell for high rigidity
5	Port plate housing	highly integrated
6	Two control pistons	hydraulically capturing the swashplate
7	Through shaft	for additional units
8	Cylinder barrel	compact due to 21° technology
9	High pressure relief valves	integrated feeding function
10	Optional PTO	pumps and motors are available with this torque transmission

Series 02-Features.

The multiple applications of Linde's Series 02 units are due to its modular design: the combination of a basic unit with the desired control element and interface option allows for an optimum design of your hydraulic system.

Linde's through drive technology for both pumps and motors allows a flexibility of design in a multitude of applications.



The advanced design of the piston-slipper assembly makes the large swash angle of 21° possible. Compact build size and long service life are immediate advantages of this 21° technology.

21° Technology.

Our base for compact peak performance.

High longevity

The hydrostatic bearing of the rotating group compensates for the axial forces. This significantly increases the life expectancy of the unit. The unique material combination of steel on steel assures a high wear resistant piston-slipper assembly hence reliable operation of our long-life units. The swash plate design tolerates high radial accelerations.

Compact design with high power density

All the Series 02 units are based on the 21° technology. The increased piston stroke together with the optimized flow paths give increased efficiency of our rotating groups which transmit more power through smaller build size. Design of rotating group and integrated controlling, regulating and safety functions lead to compact units with a high degree of integration.

Noise reduction

All design features having to do with noise emission, like hydrostatic bearing, commutation, canalling, interfaces and housing shape have been optimized in the Series 02 with regard to pulsation and noise transmission. This helps quite considerably to cut costly noise dampening measures afterwards.

Direct machine control

The machine operator's signals are precisely followed up due to load independent control elements and exact controlling behaviour of the swashplate. Drive commands are carried out on the spot; this makes the machine work responsively and efficiently. Due to the optimized swashplate concept, together with its high level of production quality, smooth starting and jerk-free operation are even possible at low rpm with high torque.

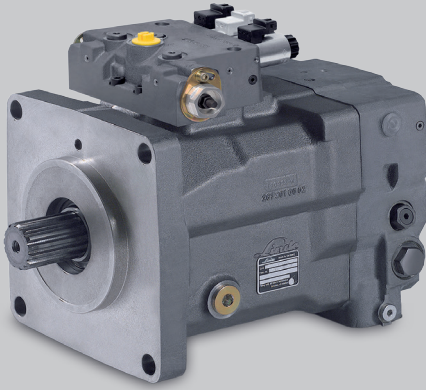

HPV-02		55	75	105	135	165	210	280
Max. displacement	cc/rev	54.7	75.9	105	135.6	165.6	210.1	281.9
Max. operating speed	rpm	3900	3400	3200	3000	2750	2300	2400
Max. speed*	rpm	4150	3600	3400	3200	2950	2500	2550
Nominal pressure	bar	450	450	450	450	450	450	450
Max. pressure**	bar	500	500	500	500	500	500	500
Torque ($\Delta p=430$ bar; charge pressure=20 bar)	Nm	374	519	719	928	1133	1438	1929
Corner power	kW	160	194	252	305	342	362	507
Weight (approx.)*** with H1-control without oil	kg	46	49	66	72	113	132	164

* highest transient speed, that can temporarily occur
 ** highest transient pressure, that can temporarily occur
 *** inclusive internal gear pump (size 55-135) or external gear pump (size 165-280)

HPV-02.

Variable pumps for closed circuit operation.

Design characteristics

- axial piston pump in swashplate design for high pressure closed circuit systems
- clockwise or counter clockwise rotation
- exact and rugged servo control devices (mechanical, hydraulic, electro-hydraulic)
- integrated high pressure relief valves with charge function
- integrated low pressure relief valves for charge and control circuits
- replaceable cartridge filter
- SAE high pressure ports
- SAE mounting flange with ANSI or SAE spline shaft
- through shaft SAE A, B, B-B and C
- charge pressure pumps for internal and external suction, integrated cold start relief valve optional
- optional tandem and multiple pumps

Controls

- M1R mechanical-hydraulic
- M2E mechanical-hydraulic with enabling solenoid
- H1 hydraulic
- H1P hydraulic with pressure cut-off
- E1 electro-hydraulic
- E1P electro-hydraulic with pressure cut-off
- E2 electro-hydraulic, with switch-off function
- E5 electro-hydraulic, 3 position
- CA speed related hydraulic mechanical with torque-/ power limiter

Control options

- power limiter

Product advantages

- compact design
- high power density
- dynamic response
- high reliability
- long service life
- noise-optimized
- precise and load-independent

Further information



- data sheet (as pdf file)
- 3D CAD models (as step/prt file)
- exploded-view drawing



Controls.

Machine control with instinctive feel.

All the controls used in the Series 02 are based on a load-independent control mechanism. No matter which control is used: identical commands always call for the same response in the machine. The sensitive and precise machine control makes work easier and increases productivity. Various customer system options for mechanical, hydraulic and electric input solutions are available. Further special regulating features like torque control and pressure cut-off are also available.

The reliable control of the pump can easily be integrated into any kind of vehicle management control system. The electronic input signals for dynamic driving behaviour control the pump independent of pump load condition.

E2 with switch-off function

Prompt response and steady flow are also characteristic for the E2 control with additional switch-off function. In this context the electronic control unit compares the travel command to other machine signals. In case of a system fault the electronic control unit will deactivate the „watchdog“-solenoid. Upon this the pump is brought to neutral under full control which ensures that the vehicle is brought to rest in a smooth jerk-free manner, without endangering the driver.

Product advantages of E2

- fulfils the high requirements of road traffic admission
- minimized susceptibility to interference
- with HMF-02: defined swivelling back of pump for controlled deceleration and stop in case of system fault
- with HMV-02: diesel overspeed protection by fast swivelling back of pump

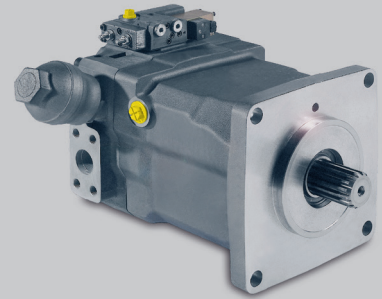

HPR-02		55	75	105	135	165	210	280	105D	125D	165D
Max. displacement	cc/rev	55	75.9	105	135.7	165.6	210.1	281.9	210	252	331.2
Max. operating speed without tank pressurization	rpm	2700	2500	2500	2350	2200	2100	2000	2450	2400	2150
Max. oil flow*	l/min	148.5	189.8	262.5	318.9	364.3	441.2	563.8	514.5	604.8	712.1
Nominal pressure	bar	420	420	420	420	420	420	420	420	380	420
Max. pressure**	bar	500	500	500	500	500	500	500	500	420	500
Torque ($\Delta p=420$ bar)	Nm	368	507	702	907	1107	1404	1884	1245	1404	1964
Corner Power	kW	104	132.8	183.8	223.2	255	308.8	394.7	360.2	383	431.8
Weight (approx.) without oil	kg	39	39	50	65	89	116	165	96	113	177

* theoretical data of a single unit without efficiency effects

** highest transient pressure, that can temporarily occur

HPR-02.

Self-regulating pumps for open circuit operation.

Design characteristics

- axial piston pump in swashplate design for high pressure open circuit systems
- clockwise or counter clockwise rotation
- self-priming at high nominal speed
- tank pressurization or swash angle reduction for high speed applications
- adaptive noise optimization SPU
- decompression fluid is discharged via pump housing to keep suction side calm
- exact and robust load sensing controllers with or without swash plate position feedback

Controller types

- LP load sensing with pressure cut-off
- H1L load sensing with hydraulic ΔpLS – override
- E1L load sensing with electrical ΔpLS – override
- LEP load sensing with electric stroke limiter and pressure cut-off
- ETP electro-proportional with hyperbolic power-limiter and pressure cut-off
- TL2 load sensing with hyperbolic power limiter

Product advantages

- optimum interaction with Linde LSC control valves and LinTronic
- energy saving operation by 'flow on demand'-control
- dynamic response
- excellent suction up to rated speed
- noise optimization over the whole range of operation
- compact design
- high power density
- long working life

Further information



- data sheet (as pdf file)
- 3D CAD models (as step/prt file)
- exploded-view drawing



Noise optimization by Linde Hydraulics. Obvious advantage for driver and environment: Less noise not only relieves the driver in the cabin, but also construction workers and residents.

SPU.

Noise optimization by commutation.

Legal emission regulations force manufacturers of mobile machinery to optimize the noise emission of their products. Since secondary measures tend to be expensive and less efficient Linde prefers to fight the noise where it is generated: by optimally connecting an additional volume directly next to the commutation of the HPR-02 pump, Linde Hydraulics invented the SPU silencer. The adaptive SPU reduces flow and pressure pulsations in the regulating pump over the entire range of operation – without loss of power. Compared to a customary variable pump, an HPR-02 with SPU reduces pulsation level by up to 70 %, independently of pressure, speed and temperature! The pulsations transmitted to system components and machine structure are significantly less, making the machine quieter.

Product advantages

- low noise level inside the cabin and outside: obvious relief for driver and environment
- self-adapting wide scale reduction of pulsation over the whole range of operation: independent of pressure, speed and temperature
- no need of costly measures for additional noise dampening
- significantly reduced noise peaks
- no effect on function and performance
- minor increase of weight and mounting space
- simple and robust design
- immediately usable, maintenance-free

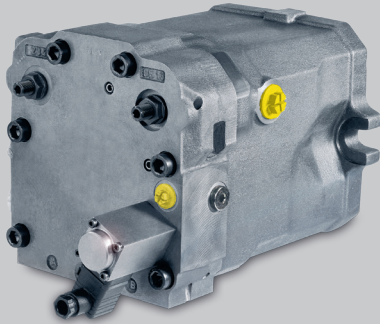

HMV-02		55	75	105	135	165	210	280	105D	135D
Max. displacement	cc/rev	54.7	75.9	105	135.6	165.6	210.1	281.9	210	271.2
Max. operating speed at V_{max}	rpm	4300	3800	3700	3200	3100	2700	2400	3300	2400
Max. speed at V_{max}^*	rpm	4400	4100	3800	3500	3400	3000	2700	3400	2700
Max. operating speed at V_{min}	rpm	4700	4400	4100	3700	3500	3200	2900	4100	2900
Max. speed at V_{min}^*	rpm	5300	5000	4700	4000	3900	3500	3200	4400	3200
Nominal pressure	bar	450	450	450	450	450	450	450	450	450
Max. pressure**	bar	500	500	500	500	500	500	500	500	500
Output torque ($\Delta p=430$ bar)	Nm	374	519	719	928	1133	1438	1929	1437	1856
Corner Power	kW	184	239	309	360	415	482	586	617	564
Weight (approx.) without oil	kg	28	32	42	56	76	101	146	98	149

* highest transient speed, that can temporarily occur

** highest transient pressure, that can temporarily occur

HMV-02.

Variable displacement motors for closed and open circuits.

Design characteristics

- axial piston motor in swashplate design for high pressure closed and open circuit systems
- optimized starting and low speed behaviour
- purge valves for circuit and case flushing optional
- stepless or 2-position control
- electric or hydraulic controls
- superposed pressure control optional
- brake pressure shut off optional
- swivelling to 0 cc/rev
- high pressure relief valves available
- through shaft with free shaft end or with coupling flange
- SAE high pressure ports radial or axial
- SAE mounting flange with ANSI or SAE spline shaft
- plug-in version optional
- speed sensor optional
- double and tandem motor available

Controls

- H1 hydraulic stepless
- H2 hydraulic 2-position
- H4 hydraulic stepless $V_{min}=0$ cc/rev
- E1 electro-hydraulic stepless
- E2 electro hydraulic 2-position
- E4 electro hydraulic stepless $V_{min}=0$ cc/rev
- E6 as E4 with inverted shifting
- EH1P-CA hydraulic stepless with pressure override and electric pressure selection

Product advantages

- jerk-free low speed
- high starting torque
- large conversion range
- zero angle possible
- dynamic response
- PTO through-drive motor
- compact design
- high power density
- long service life

Further information



- data sheet (as pdf file)
- 3D CAD models (as step/prt file)
- exploded-view drawing



Hydraulic motors by Linde Hydraulics with optimized low speed properties make it possible to apply a smooth and uninterrupted road cover. Linde technology provided on a smooth level.

Low Speed Concept. Precision by innovative drive system.

Standard hydraulic motors at low speeds in their starting phase cannot generate the necessary torque. Therefore, the power of the fast spinning hydraulic motors has to be reduced by means of several step gearboxes down to the speed needed on the wheel. Somewhat higher windage losses and poorer mechanical efficiency are benevolently accepted in this context.

Quite the opposite holds true for the motors by Linde Hydraulics: The motors of the Series 02 are capable of transmitting the required torque even at low speed and make it possible to start smoothly and sensitively. Therefore, additional gear ratios for rpm reduction are not necessary.

Product advantages

- jerk-free and steady low speed behaviour
- fuel saving in all operating situations
- elimination of mechanical gearboxes
- quieter through speed reduction
- less maintenance because of simplified drive concept
- increased service life of the transmission

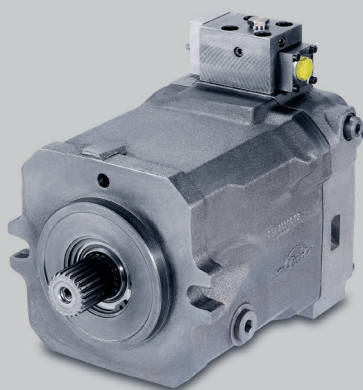

HMR-02		55	75	105	135	165	210	280
Max. displacement	cc/rev	54.7	75.9	105	135.6	165.6	210.1	281.9
Max. operating speed at V_{max}	rpm	4300	3800	3700	3200	3100	2700	2400
Max. speed at V_{max}^*	rpm	4400	4100	3800	3500	3400	3000	2700
Max. operating speed at V_{min}	rpm	4700	4400	4100	3700	3500	3200	2900
Max. speed at V_{min}^*	rpm	5300	5000	4700	4000	3900	3500	3200
Nominal pressure	bar	450	450	450	450	450	450	450
Max. pressure**	bar	500	500	500	500	500	500	500
Output torque ($\Delta p=430$ bar)	Nm	374	519	719	928	1133	1438	1929
Corner Power	kW	184	239	309	360	415	482	586
Weight (approx.) without oil	kg	28	32	42	56	76	101	146

* highest transient speed, that can temporarily occur
 ** highest transient pressure, that can temporarily occur

HMR-02.

Self-regulating motors for open and closed circuits.

Design characteristics

- axial piston motor in swash plate design for high pressure open and closed circuit systems
- optimized starting and low speed behaviour
- purge valves for circuit and case flushing in closed circuit optional
- internal system pressure control, no external piping required
- brake pressure shut off for closed circuit
- high pressure relief valves available
- through shaft with free shaft end or with coupling flange
- SAE high pressure connection ports radial or axial
- SAE mounting flange with ANSI or SAE spline shaft
- plug-in version optional
- speed sensor optional
- counter balance valve optional

Maximum displacement override

- pneumatic
- hydraulic (high and low pressure)
- electric

Product advantages

- steady low speed behaviour
- high starting torque
- large conversion range
- PTO through-drive motor
- compact design
- high power density
- high reliability
- long service life
- dynamic response

Further information



- data sheet (as pdf file)



Compact machines call for compact drive solutions. Less is more. The new PTO Through-Drive Motor. The compact drive solution for more installation space and increased efficiency.

PTO Through-Drive Motors. Breakthrough in drive system design.

In conventional drives the torque of the hydraulic motor can be transmitted to the cardan shaft only by means of a dropbox. For further optimization of the drive train Linde Hydraulics developed the PTO Through-Drive Motor. Based on the standard hydraulic motor of the Series 02 with just one shaft end, the PTO Through-Drive Motor offers two shaft ends to transmit the torque.

Hence the machine designer can conceive the hydraulic motor to fit directly and immediately into the drive train thus saving mounting space. The dropbox usually needed in a conventional propulsion drive can be saved. This reduces both noise emission and fabrication cost of the entire vehicle while overall efficiency increases.

Product advantages

- dropbox eliminated
- more installation space
- optimized drive concept
- low maintenance transmission
- reduced noise
- increased drawbar pull
- fuel saving
- ideal drive solution for municipal vehicles, wheeled loaders, telescopic handlers and forest machines

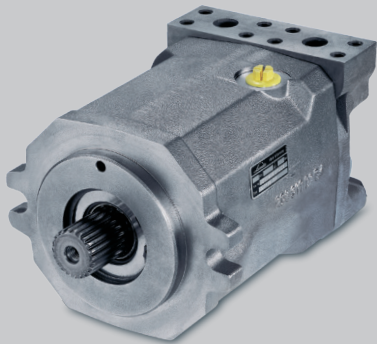

HMF-02/HMA-02		28	35	55	75	105	135	165	210	280
Displacement	cc/rev	28.6	35.6	54.7	75.9	105	135.6	165.6	210.1	281.9
Max. operating speed	rpm	4300	4300	4300	3800	3700	3200	3100	2700	2400
Max. speed*	rpm	4400	4400	4400	4100	3800	3500	3400	3000	2700
Nominal pressure	bar	450	450	450	450	450	450	450	450	450
Max. pressure**	bar	500	500	500	500	500	500	500	500	500
Output torque ($\Delta p=430$ bar)	Nm	196	244	374	519	719	928	1133	1438	1929
Corner Power	kW	88	110	169	207	278	311	368	407	485
Weight (approx.) without oil	kg	16	16	19	26	33	39	76	101	146

* highest transient speed, that can temporarily occur
 ** highest transient pressure, that can temporarily occur

HMF-02/HMA-02.

Fixed displacement motors for open and closed circuits.

Design characteristics

- axial piston motor in swashplate design for high pressure open and closed circuit systems
- optimized starting and low speed behaviour
- purge valves for circuit and case flushing optional
- high pressure relief valves set fixed or variable optional
- SAE mounting flange with ANSI or SAE spline shaft

Product advantages

- steady low speed
- high starting torque
- compact design
- high power density
- high reliability
- long service life

Design characteristics HMA

- motor set to a fixed, customer specific displacement ex works

Further information



- data sheet (as pdf file)
- 3D CAD models (as step/prt file)
- exploded-view drawing



Linde

H35

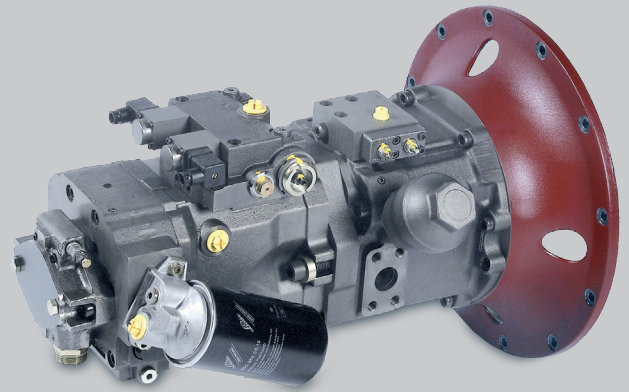
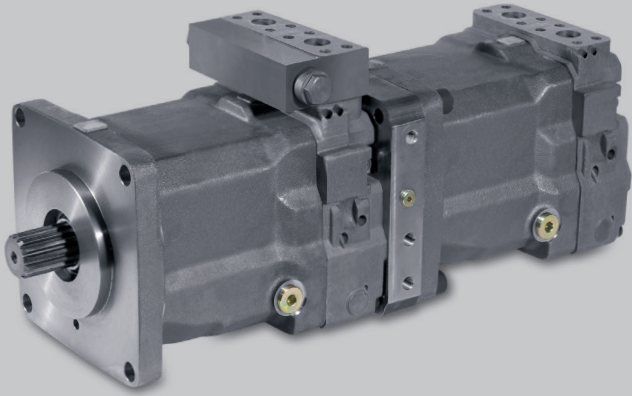

Multiple units.

Double-, tandem- and multiple pumps are set up by combining our variable displacement pumps and self-regulating pumps. They can either supply larger volume flows or feed different circuits.

The rated size and the type of the pump for open or closed circuits are variable. The sequential arrangement is determined by the maximum torque which can be transferred.

Due to their swashplate design our motors can also be combined to form double and tandem motors.



Multiple units.

For open and closed circuit operation.

Design characteristics HPR double pumps

- two pumps of the same rated size, fitted back-to-back
- common port plate housing
- single or dual circuit

Design characteristics tandem- and multiple pumps

- two or more pumps, fitted face-to-back
- open and/or closed circuit
- tandem pumps: Pumps of the same type
- multiple pumps: Pumps of different types

Design characteristics HMV double motors

- two motors of the same rated size, fitted back-to-back
- common ports for high pressure, servo- and control pressure
- can be controlled individually or together
- both motors can be swivelled to 0 cc/rev

Design characteristics tandem motors

- two motors of the same type, fitted face-to-back
- separate ports, individual control possible
- both motors can be swivelled to 0 cc/rev

Product advantages double, tandem and multiple pumps

- only one drive shaft required
- no splitter box required for the pumps
- compact design
- individual control of each single pump
- no adverse influence on functionality of the single rotating groups
- advantages such as high dynamics and precise control remain in full

Product advantages double motors

- high conversion range for smooth acceleration
- simplified drive train
- high tractive effort and high final speed
- fast control response and high starting torque

Product advantages tandem motors

- double torque with the same gearbox interface by using the same flange as with the single motor
- direct installation in the drive train, gearbox can be omitted
- increased rotating speed and narrower dimensions than for single motors of the same nominal size in swash plate or bent axis design

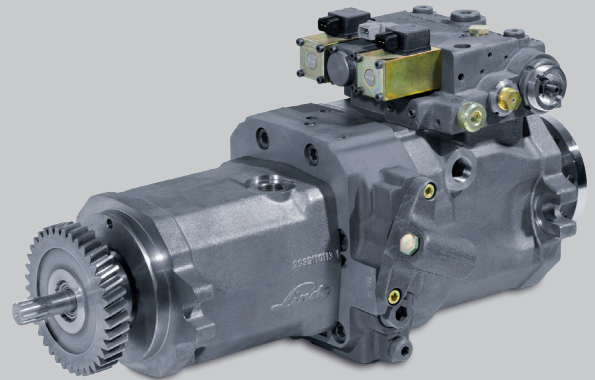
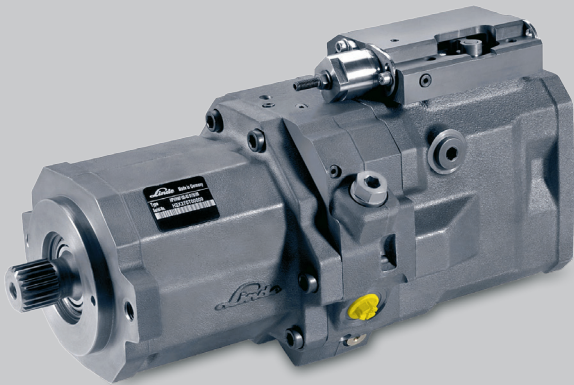

K-02 units.

Together with the customer Linde Hydraulics defines new standards in technology. Advanced modular drive technology, realised in hydrostatic variators for variable speed transmission, form the core of power split gearboxes. Compact units with a hollow shaft are available for mounting to conventional gearboxes in smaller machines. These compact units are used as fully hydrostatic systems with PTO drive. With customer-specific developments, Linde Hydraulics supports the change from power shift to continuous variable transmission technology.



Precise transmission control for simple operation without interrupting tractive effort. From stand still to maximum speed. Stepless.

K-02 units. Stepless for optimum performance.

Design characteristics

- variable displacement pump HPV-02 and fixed displacement motor HMF-02 back-to-back in one common unit
- inline-configuration
- integrated high pressure relief valves with charge and discharge function
- external feed
- electric or hydraulic pump control

Version for gearbox installation

- optimized for power split transmissions
- customized enclosure geometry
- engine power 120 - 165 kW

Version for gearbox extension

- fully hydrostatic unit for mounting on conventional gearbox
- PTO version with power take-off
- engine power up to 45 kW

Product advantages

- accurate control of volume flow
- exact gear shift without interrupting tractive effort
- dynamic response
- standstill control
- sensitive start-up
- precise crawling speed
- high efficiency
- low fuel consumption over entire operating range
- compact design
- high reliability
- long service life



Medium pressure pumps.

In addition to the 02 high pressure series, Linde Hydraulics offers a selection of medium pressure pumps for a variety of purposes. Demand-based supply of the actuators to make the overall system as efficient as possible is also the centrepiece of these units. With having identical service intervals, heavy duty medium pressure pumps are the perfect supplement to the 02 series of hydrostatic systems in more powerful machines for tougher applications.

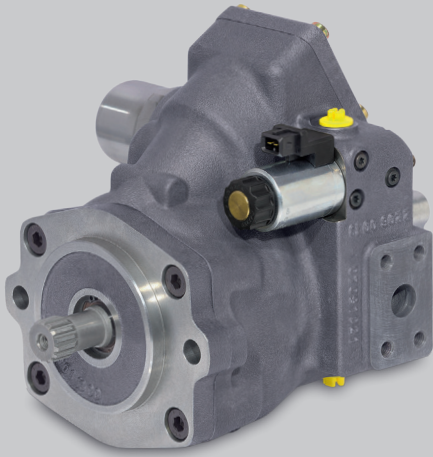

MPR 50		50	+ IGP
Max. displacement	cc/rev	50	16
Max. operating speed at 1 bar (absolute pressure)	rpm	3100	3100
Max. operating speed at <35 cc	rpm	3600	3600
Nominal pressure	bar	320	80
Max. pressure*	bar	350	110
Max. power at nominal pressure and maximum operating speed	kW	82.7	6.6
Weight (approx.) inclusive IGP	kg	26	26

* highest transient pressure, that can temporarily occur

MPR 50.

Design characteristics

- electro-hydraulic position feedback control
- mechanical feedback
- spring support for swivelling back
- pulsation damping
- fail-safe V_{\min}
- integrated charge pump with common suction port

Charge pump IGP

- integrated, 16 cc/rev displacement
- common suction port with MPR
- pressure-proof, suitable for fan drive

Product advantages

- very short design
- low pulsation and low noise
- integrated charge pump
- pump position at standstill: $V = V_{\min}$
- suitable for rough application conditions
- integration in electronic machine management



LSC Linde Synchron Control-System.

As a pioneer of load sensing technology, Linde has more than 25 years of experience in challenging applications in open circuits. Compared to other systems, LSC enhances fuel economy up to 10 %. On-demand flow control of the regulating pump and elimination of bypass flow losses due to the “closed centre” design of the directional control valves prevent wasting energy and fuel. Sensitive controllability that can be accurately reproduced and the compensation for load influences ensure that the machine is intuitive to operate, making readjustments unnecessary. Even at system saturation, normal handling is ensured thanks to proportional flow distribution. This saves time and increases efficiency.

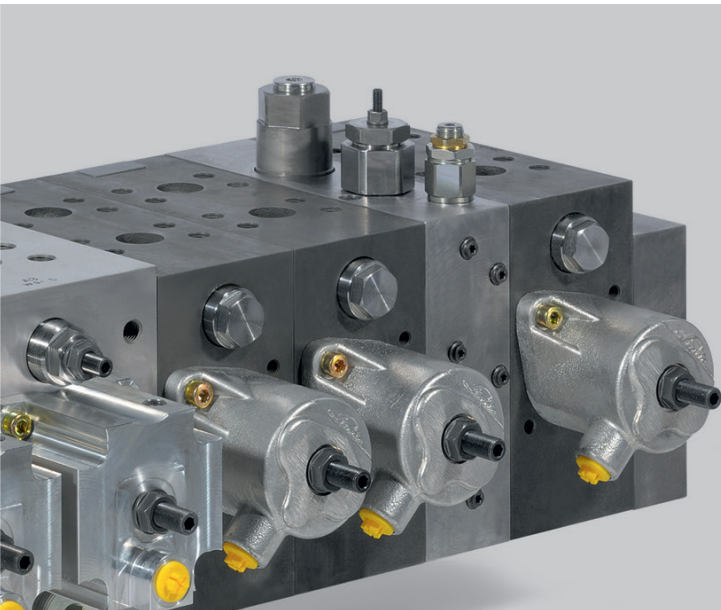

LSC stands for high handling performance due to load-independent and sensitive machine conduct. Fast and direct.

LSC Linde Synchron Control-System.

Intelligent distribution of fluid.

Design characteristics

- directional control valves in "closed centre" design
- "post compensated" system with downstream compensators
- valve control spool with integrated compensators and pressure copiers
- parallel valve arrangement
- compensation of load influences
- actuator supply as needed
- proportional flow distribution in case of system saturation

Product advantages

- approved quality since LSC-introduction in 1984
- system can be individually adapted to customer specifications
- supply to additional actuators is optional
- simple system control
- electronic override of the LS signal is feasible
- simultaneous motion of several actuators without reciprocal or with defined influence
- maintaining of volume flow distribution ratios, even at system saturation, all actuators remain active
- intuitive, sensitive operation due to compensation of the load influences - even with combined movements
- low fatigue working
- high handling performance
- low energy consumption
- high system efficiency

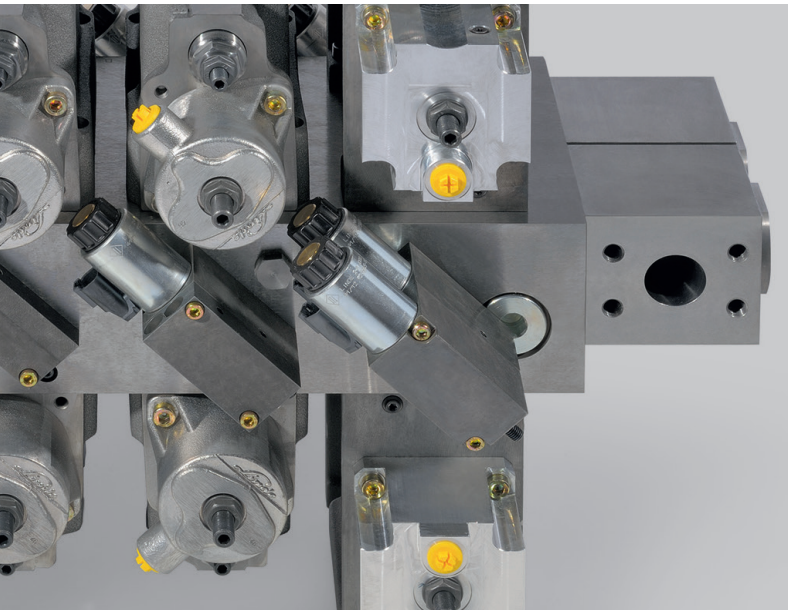

LSC Linde Synchron Control-System. Adaptive electro-hydraulic control.

With its latest LSC generation, Linde combines the design characteristics of the proven LSC system with the benefits of the electric control. The powerful electronic control unit recognises the operator's command by the amplitude and the speed with which the joysticks are being moved. It then sets the pump and the valves according to the dynamic demand. Due to the overlaid, classic load-sensing control mechanism, no sensors are needed. All components are provided by a single source and matched perfectly with each other. The operator can change the system's behaviour electronically with regard to its dynamics and fine control, as well as its dependency or independency on the load.

This enables multi-purpose machines which can quickly be optimized to the specific use by the operator. With completely opened valves, the actuators can be controlled exclusively via the pump's control to achieve the maximum possible efficiency.

Design characteristics

- core components of the proven LSC system
- robust system without sensors
- electronic joysticks and powerful electronic control unit
- electric control of pump and valve plate
- suitable for single circuit and intelligent multiple circuit systems
- simple control via CAN-interface for the display

Product advantages

- direct response behaviour
- most simple machine operation
- further increase in energy efficiency
- automatic recognition of the working condition in high dynamic or fine control mode
- automatic optimization of typical tasks like grading or shaking the bucket of an excavator
- manual adjustment of load dependent or load independent system behaviour and system dynamics by the operator
- optional prioritization of actuators with each other enables an adjustment to the current situation, like e.g. the space curve

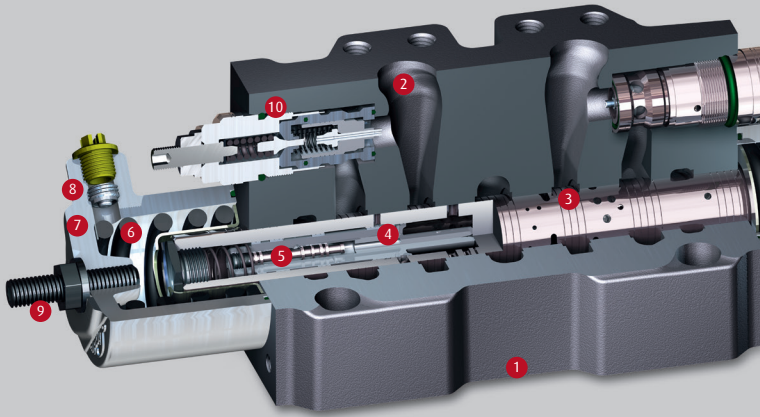

Design characteristics directional control valves

1	Load Sensing directional control valve	shown as sub plate mounted valve, alternatively available as sandwich valve
2	Cross-sections	thoroughly dimensioned in several nominal sizes
3	Valve control spool	with integrated compensators and pressure copiers
4	Compensator	downstream, for compensation, 1 per side
5	Pressure copier	integrated in compensator, 1 per side
6	Centring spring	in 2 versions for 2 pilot pressure ranges
7	Shim	independently adjustable start of function on each side
8	Throttle check valve	in pilot pressure port, adjusting valve dynamics
9	Mechanical stroke limiter	independent flow limitation on each side
10	Pilot-operated work port relief valves	with flat flow-pressure characteristic, make-up function optional

LSC valve technology.

Basis of individual machine characteristics.

The directional control valves are at the core of every manifold plate in LSC technology. Compared to other load sensing directional control valves, LSC directional control valves stand apart, in particular, thanks to the integrated downstream pressure compensators and pressure copiers. This arrangement prevents the actuator from lowering when the function starts. As a result of the compact design, the oil flow only needs to pass through the valve once and not several times. This ensures optimized flow passages in the directional control valve. Due to the high-precision production of the directional control valves, there is only minimal leakage even at high load, which is beneficial to the load holding function of the valves.

Design characteristics

- closed centre load sensing directional control valves in piston design
- downstream compensators (post compensated system)
- valve control spool with integrated compensators and pressure copiers
- optimized flow paths
- side-selective configurable start of function
- individual characteristic due to separate compensators and pressure copiers for sides A and B
- side-selective flow restriction
- prioritization of individual actuators
- hydraulic or electric proportional control

Product advantages

- high efficiency due to little flow losses
- no lowering at start of function
- no separate load holding valve necessary
- quick-reacting pressure cut-off
- work port relief valve with integrated anti-cavitation function
- horizontal or vertical installation
- simple functional enhancement
- fast machine response and low hysteresis in control

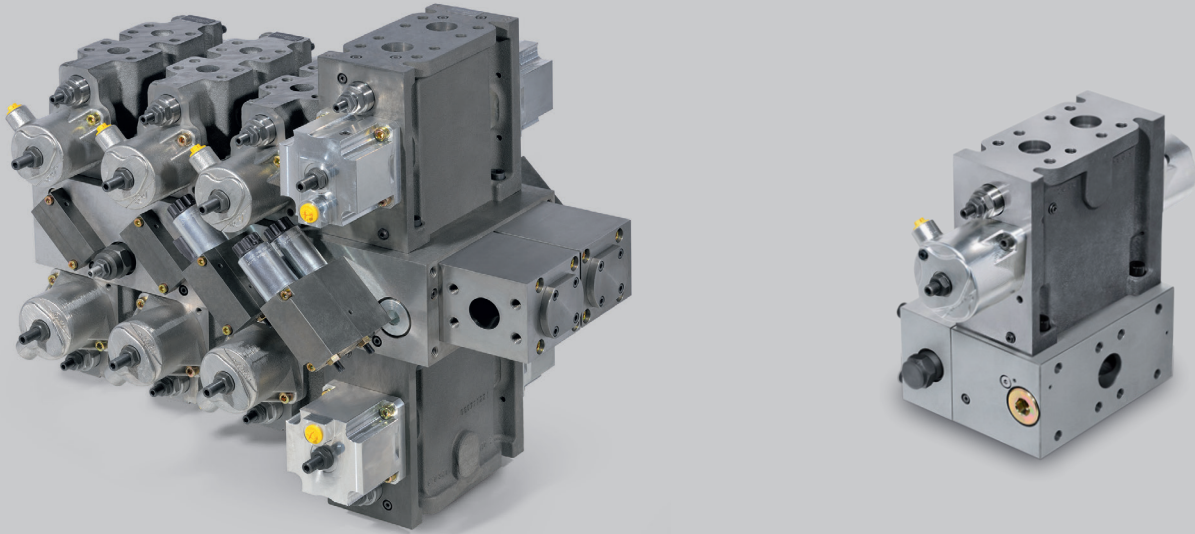

VT modular. More flexibility.

Manifold valve plates of series VT modular are made up of individual components of a modular building block system. This is why manifold valve plates can be configured to optimally match any application with one up to eight actuators.

Design characteristics

- directional control valves available as sub plate mounted valves
- designed for the Linde Synchron Control (LSC) – Load Sensing System
- nominal sizes 25 and 30
- flows up to 600 l/min (size30)
- modular design for the configuration of valve plates for 1-8 actuators
- optionally with hydraulic, electric or combined piloting

Product advantages

- all advantages of the LSC valve technology
- easy to configure building block system
- adjustable to the target application
- quick availability
- ideal for machines with low production volume

Further information



- data sheet (as pdf file)
- 3D CAD models (as step/prt file)

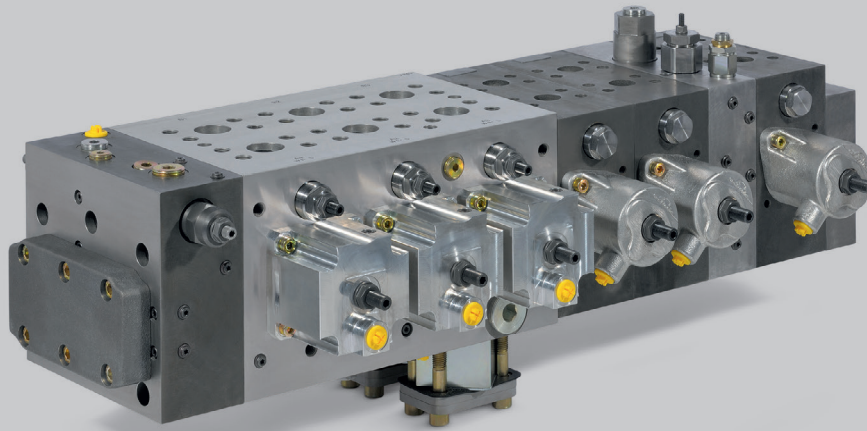

Monoblock.

Compact design.

Three directional control valves in a common housing form the base of the manifold valve plate in monoblock design. This results in the most compact package.

Design characteristics

- basic block: three directional control valves of identical nominal size in one cast housing
- designed for the Linde Synchron Control (LSC) - Load Sensing System
- nominal sizes 30, 25 and 18
- flows up to 600 l/min (size 30)
- broad dimensioned diameters and flow-optimized design of the supply channels
- extendable with directional control valves in sandwich design, in identical or differing nominal size
- pressure cut-off and additional functions integrated in connection plate
- special functions via intermediate plates
- optionally with hydraulic or electric piloting

Product advantages

- all advantages of the LSC valve technology
- compact design
- full-size expandability
- high efficiency achieved by flow-optimized channels even for applications with numerous actuators

Further information



- brochure (as pdf file)



Swing drive solutions.

High handling capacity and supreme driver comfort is not only a matter of the installed power but also demands smooth motion and precise positioning of the upper carriage. We offer various combinations of gearboxes, motors and means of control, always focused on meeting customers' requirements in terms of dynamics, controllability and accuracy.

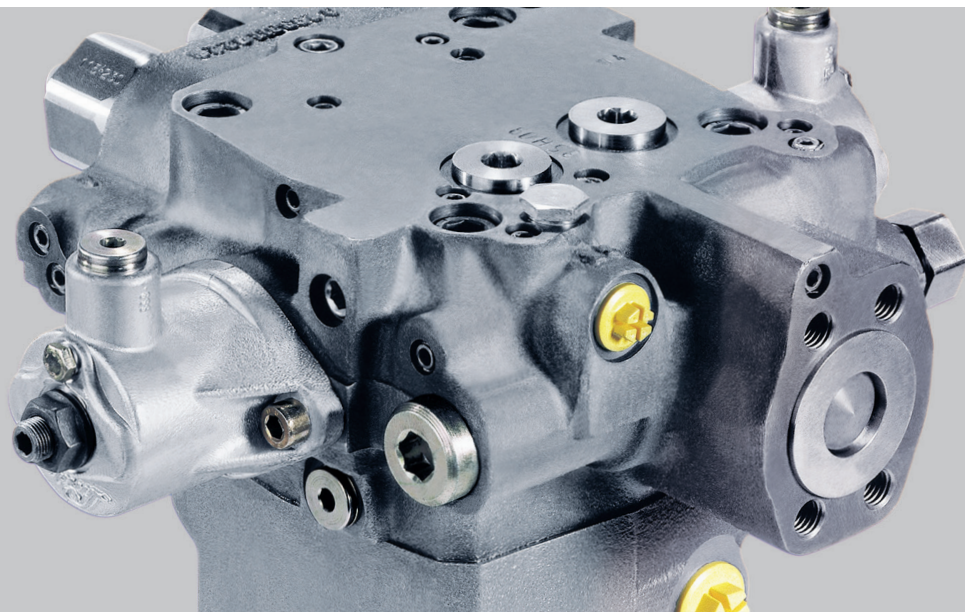

HMF-02 P.

Fixed displacement motors with integrated swing drive functions.

Design characteristics

- directional control valve function swing
- torque control-function
- high pressure relief valves with controllable characteristic
- priority function
- secondary relief combined with make up function
- anti-reaction function
- discharge function
- anti-shock valve

Product advantages

- smooth low-speed operation
- high starting torque
- torque and speed control
- controllable counter-rotation
- compact design
- high power density
- high reliability
- long service life

Alternative solution

- swing drive function in closed circuit design with standard fixed displacement motor HMF-02 and high pressure pump HPV-02 with special torque-control



LinTronic.

Modern machines benefit from the advantages provided by an intelligent electronic control: Increased comfort, machine variants realised by software instead of differing components and a further reduction of fuel consumption and emissions.

Linde accompanies this development from the very beginning and complements the components of the power-train with electronic products of the LinTronic family, in the accustomed quality and reliability.



LINC Series	LINC 1
Digital inputs	4 x Pull-up
Digital inputs	6 x Pull-down
Analogue inputs	6 x 0-5 V
Frequency inputs	3 x 0-10 kHz
PWM outputs	7 x max. 2.0 A
Low-Side outputs	4 x max. 0.5 A
External power supply	1 x 5 V
Communication	1 x CAN Bus
Dimensions (approx.)	147 x 140 x 50 mm

Electronic control units.

For open and closed circuit applications.

Linde controllers from the LINC series are characterised by high mechanical and electrical stability. The core of the components is formed by a function and safety controller. LINC control units are used on their own or in combination with one another, both for hydraulic and electric drives and combinations of both drive types. In addition to the drive components joysticks, pedals and the combustion engine can be integrated into the regulation concept. Thanks to efficient mode selection and an increase of user-friendliness, they achieve enhanced power utilisation and thus also reduce pollutant and noise emissions.

Design characteristics

- redundant safety concept with function and safety controller
- preconfigured setup
- operating voltage 8-32 VDC
- protected against reverse polarity
- protection against short-circuits, all inputs protected against operating voltage and earth
- freely definable switching and proportional outputs
- communication via CAN bus
- conforms to EU directive 2004/108/EC
- resistant against vehicle electrical system impulses in accordance with ISO 7637-2
- robust and leak proof housing for mobile application
- protection class IP67 as per EN 60529
- resistant against salt spray, hydraulic oil, diesel, UV radiation, fertiliser

Product advantages

- management of the entire machine drive via just one electronic control unit
- optimum interaction of hydraulic and electric drive components from Linde
- high availability and reliability
- can guarantee safety functions up to performance level d in accordance with DIN EN ISO 13849-1
- can be used in applications in the scope of the German Regulations Authorising the Use of Vehicles for Road Traffic (StVZO)
- can be configured to input peripherals customary in the market
- machine behaviour can be configured on individual basis
- simple parametrising process and diagnostics with LinDiag®
- suitable for open and closed circuit applications and combinations of both



1



2

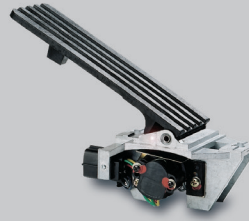

3



4

LinTronic.

Peripheral equipment.

1. Joystick, electronic CEH 80

2-way/ 4-way electronic control stick, transverse axis spring centred; brake and 3 position version optional for longitudinal axis. Optional additional functions in handle like buttons and thumb wheel. This product is suited for console mounting, left or right version available

2. Joystick LLC

Potentiometer joystick, stabilized voltage supply 5 V - 15 V, spring-centred, suitable for armrest mounting, various versions, e.g. single lever, 4-way version available

3. Throttle / inch pedal CEH 20

Drive pedal or inch pedal for reduction of reference value, stabilized supply voltage 5 V - 15 V, robust die cast console.

4. F-N-B travel direction switch CEH-25

3 positions for forward, neutral and backward signal, ergonomic actuator, switching voltage up to 70 V.



5



6



7



8

LinTronic.

Peripheral equipment and sensors.

5. Solenoid CEA-2x

37 mm-type solenoid in proportional or on/off version. For electro-mechanical valve control of pumps, motors, proportional valves and directional control valves. Magnetic force up to 55 N.

6. Swash angle sensor CEH 07

Linear Hall-effect angle sensor with spring reset force for HPV-02.

7. Speed sensor CEH 11

NAMUR speed sensor for diesel engine, single channel up to 6.6 kHz.

8. Pressure sensor CEH 50

For high pressure detection, various types with pressure ranges of 40, 60 and 600 bar, analogue output signal 0.5 V - 4.5 V, stabilized supply voltage 5 V or 8 V - 36 V.

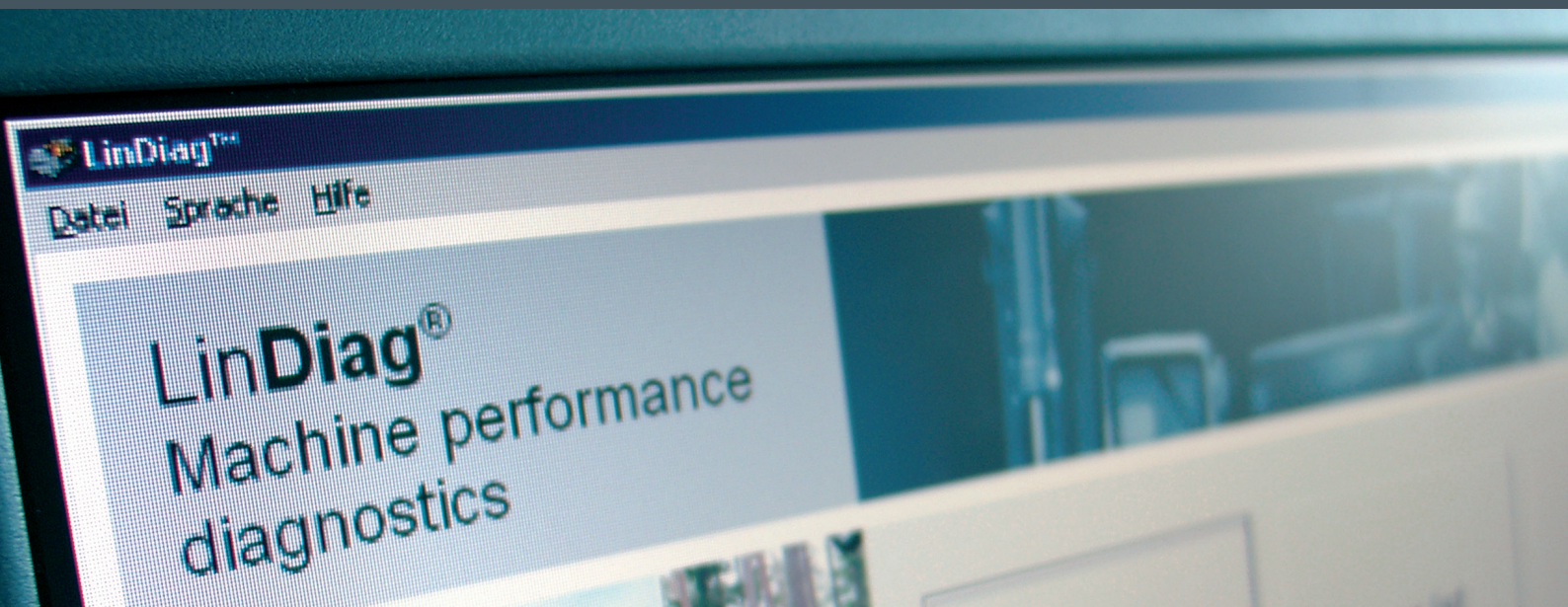

LinDiag®

Software for set up and diagnostics.

Characteristics

- compatible with Linde Hydraulics electronic controls
- suited for PC /laptop with Windows operating system with serial or USB interface
- operated by mouse, key or pad
- diagnostics
- documentation and reporting
- harness checking
- parameterization
- "Teach in" of components
- data logger
- electronic box restorable to factory setting

Product advantages

- optimum system usage by teach-in function
- error prevention through continual comparison and documentation of the variance
- user-friendly software up-dating ("flashing")
- easy usage by self-explanatory user surface
- large letters and buttons offer optimum use even with the machine running
- self-adapting screen size
- multi-lingual, up to 10 languages can be programmed
- documentation exportable into MS Office
- practical-minded partition of control elements by functional groups
- modular set-up: individual functions can be added optionally later

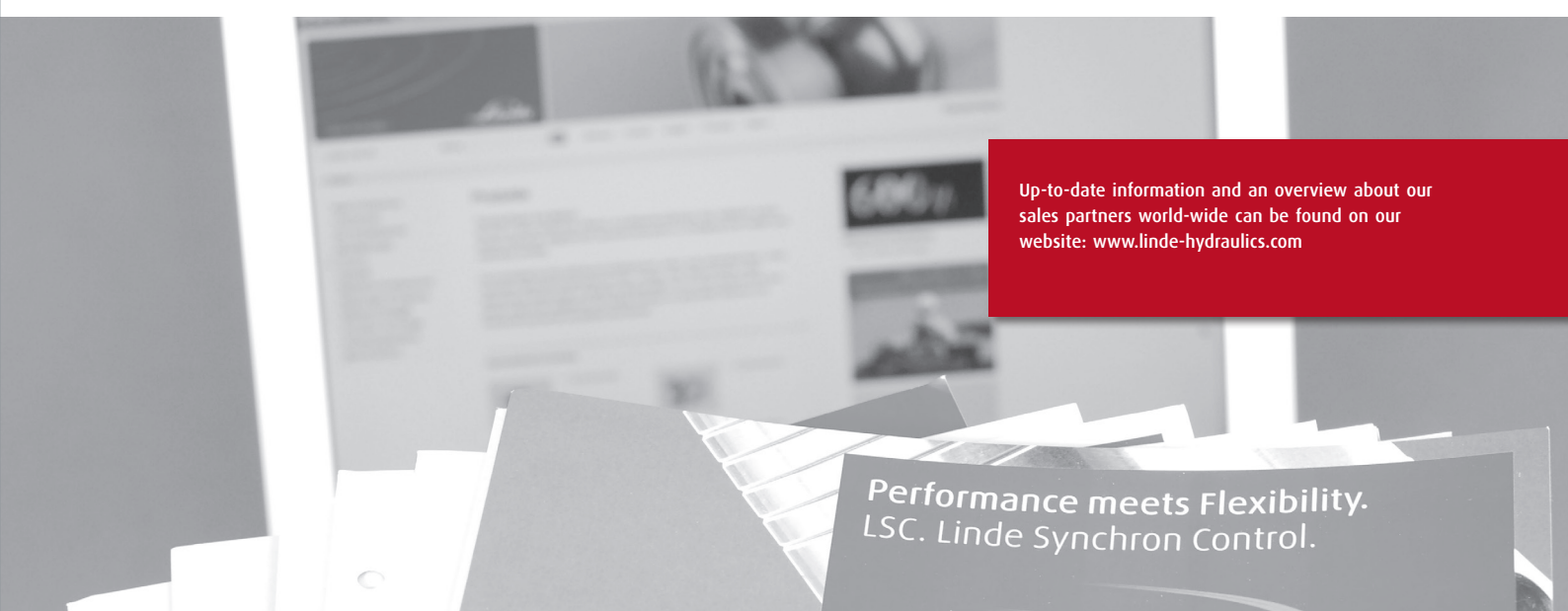

Up-to-date information and an overview about our sales partners world-wide can be found on our website: www.linde-hydraulics.com

Performance meets Flexibility.
LSC. Linde Synchron Control.

Well-informed.

Our current print media at a glance.

Product Catalogue

- **Turning Power into Motion.** Product catalogue

Brochures

- **LinDrive.** The unbeatable driving experience.
- **Drive Systems for Construction Machines.**
- **Drive Systems for Agricultural Machines.**
- **Drive Solutions for Cranes.**
- **Drive Solutions for Dozers.**
- **Drive Solutions for Excavators.**
- **Drive Solutions for Rollers.**
- **Drive Solutions for Wheeled Loaders.**
- **LSC. Linde Synchron Control.** Performance meets flexibility.
- **VW M3.** LSC directional control valves in monoblock design.

Data Sheets

- **Model Code.** Configuration of the series 02.
- **HMF/A/V/R-02.** Hydraulic motors for closed and open loop operation.
- **HPR-02.** Self-regulating pumps for open loop operation.
- **HPV-02.** Variable pumps for closed loop operation.
- **VT modular.** Modular system for LSC manifold valve plates.
- **LINC.** Universal electronic drive control
- **Mineral-oil-based Hydraulic Fluids.**

How to reach us.

Post Linde Hydraulics GmbH & Co. KG
Wailandtstraße 13
63741 Aschaffenburg, Germany

Phone +49.60 21.150-00 switchboard
Fax +49.60 21.150-142 61

E-Mail info@linde-hydraulics.com
Internet www.linde-hydraulics.com

Linde Hydraulics Worldwide.

(E) Linde Hydraulics Iberica
Avda. Prat de la Riba, 181, 08780 Palleja (Barcelona), Phone +34 93 663 32 58, info@linde-hydraulics.com.es

(F) Linde Hydraulics France SARL EST
1, rue du Maréchal de Lattre de Tassigny, 78990 Elancourt, Phone +33 1 30 68 45 40, jean.Bonati@linde-hydraulics.com

Linde Hydraulics France SARL OUEST
1, rue du Maréchal de Lattre de Tassigny, 78990 Elancourt, Phone +33 1 30 68 45 40, Jean-philippe.chaponneau@linde-hydraulics.com

(GB) Linde Hydraulics UK
12-13 Eyston Way, Abingdon Oxfordshire OX14 1TR, Phone +44 1235 522 828, enquiries@lindehydraulics.co.uk

(I) Linde Hydraulics Italia
Viale dell'Unione Europea, 33, 21013 Gallarate (VA), Phone +39 0331 1824910, info.it@linde-hydraulics.com

(USA) Linde Hydraulics USA
5089 Western Reserve Road, Canfield Ohio 44 406, Phone +1 330 533 6801, info.us@linde-hydraulics.com

(BR) Linde Hydraulics do Brasil
Rua Victorino, 134 Jardim Mutinga 06463-290 - SP, Brazil, Phone +55 11 99 18 20 438, info.br@linde-hydraulics.com

(VRC) Linde Hydraulics China
No. 197 Fushou East Road, 261000 Weifang, Phone +86 536 50 75 268, info@linde-hydraulics.com.cn
No. 89 Jinshang Road, 361009 Xiamen, Phone +86 592 53 87 701, info@linde-hydraulics.com.cn

Visit www.linde-hydraulics.com/worldwide to find a dealer close to you.



Turning Power into Motion.

Linde Hydraulics

Linde